

Filters & Wave Shaping

Passive Filters & Wave Shaping

What you'll learn in Module 8.

Module 8 Introduction

Recognise passive filters with reference to their response curves.

- High pass, Low pass, Band pass, Band stop.

Section 8.1 Differentiators.

Recognise typical filter circuits.

- RC, LC and LR filters.
- Uses for passive filters

Recognise packaged filters.

- Ceramic filters, SAW filter, Three-wire encapsulated filters.

Section 8.2 How Filters Work

Passive filters, frequency selective attenuation, phase change with reference to phasor diagrams.

- High pass and Low pass filters.

Section 8.3 Bode Plots

Bode Plots, the use of Bode plots to describe:

- Attenuation.
- Phase Change

Section 8.4 Differentiators

The use of RC filters in waveshaping on non-sinusoidal waveforms.

- Differentiation.

Section 8.5 Integrators

The use of RC filters in waveshaping on non-sinusoidal waveforms.

- Integration.

Section 8.6 Filter Quiz

Introduction to Passive Filters

Passive filters, often consisting of only two or three components, are used to reduce (ATTENUATE) the amplitude of signals. They are frequency selective, so they can reduce the signal amplitude at some frequencies, without affecting others. Filter circuits are named to show which frequencies they affect.

Fig 8.0.1 shows the symbols used in block (system) diagrams for some filters, and beside them a diagram representing the frequency response of that filter. The block diagrams indicate the frequency that is attenuated by showing three sine waves with one or two crossed out, the vertical position of the wave indicating high medium or low frequencies.

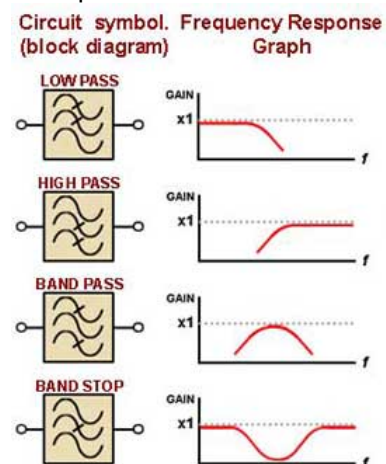

Fig 8.0.1

To indicate the effect a filter has on wave amplitude at different frequencies, a frequency response graph is used. This graph plots gain (on the vertical axis) against frequency, and shows the relative output levels over a band of different frequencies.

Passive filters only contain components such as resistors, capacitors, and inductors. This means that, the signal amplitude at a filter output cannot be larger than the input. The maximum gain on any of the frequency response graphs is therefore slightly less than 1.

The main difference between passive filters and active filters (apart from the active filter's ability to amplify signals) is that active filters can produce much steeper cut off slopes. However, passive filters do not require any external power supply and are adequate for a great many uses.

Module 8.1 Passive Filters

Uses for passive filters.

Filters are widely used to give circuits such as amplifiers, oscillators and power supply circuits the required frequency characteristic. Some examples are given below. They use combinations of R, L and C

As described in Module 6, Inductors and Capacitors react to changes in frequency in opposite ways. Looking at the circuits for low pass filters, both the LR and CR combinations shown have a similar effect, but notice how the positions of L and C change place compared with R to achieve the same result. The reasons for this, and how these circuits work will be explained in Section 8.2 of this module.

Low pass filters.

Low pass filters are used to remove or attenuate the higher frequencies in circuits such as audio amplifiers; they give the required frequency response to the amplifier circuit. The frequency at which the low pass filter starts to reduce the amplitude of a signal can be made adjustable. This technique can be used in an audio amplifier as a "TONE" or "TREBLE CUT" control. LR low pass filters and CR high pass filters are also used in speaker systems to route appropriate bands of frequencies to different designs of speakers (i.e. 'Woofers' for low frequency, and 'Tweeters' for high frequency reproduction). In this application the combination of high and low pass filters is called a "crossover filter".

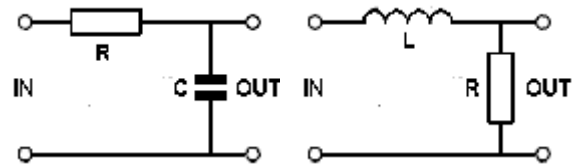

Both CR and LC Low pass filters that remove practically ALL frequencies above just a few Hz are used in power supply circuits, where only DC (zero Hz) is required at the output.

High pass filters.

High pass filters are used to remove or attenuate the lower frequencies in amplifiers, especially audio amplifiers where it may be called a "BASS CUT" circuit. In some cases this also may be made adjustable.

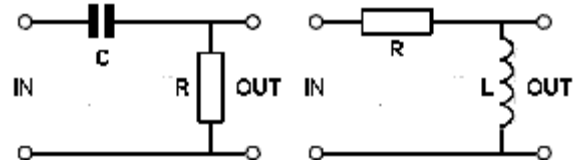

Band pass filters.

Band pass filters allow only a required band of frequencies to pass, while rejecting signals at all frequencies above and below this band. This particular design is called a T filter because of the way the components are drawn in a schematic diagram. The T filter consists of three elements, two series connected LC circuits between input and output, which form a low impedance path to signals of the required frequency, but have a high impedance to all other frequencies.

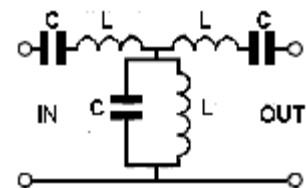

Additionally, a parallel LC circuit is connected between the signal path (at the junction of the two series circuits) and ground to form a high impedance at the required frequency, and a low impedance at all others. Because this basic design forms only one stage of filtering it is also called a 'first order' filter. Although it can have a reasonably narrow pass band, if sharper cut off is required, a second filter may be added at the output of the first filter, to form a 'second order' filter.

Band stop filters.

These filters have the opposite effect to band pass filters, there are two parallel LC circuits in the signal path to form a high impedance at the unwanted signal frequency, and a series circuit forming a low impedance path to ground at the same frequency, to add to the rejection. Band stop filters may be found (often in combination with band pass filters) in the intermediate frequency (IF) amplifiers of older radio and TV receivers, where they help produce the frequency response curves of quite complex shapes needed for the correct reception of both sound and picture signals. Combinations of band stop and band pass filters, as well as tuned transformers in these circuits, require careful frequency adjustment.

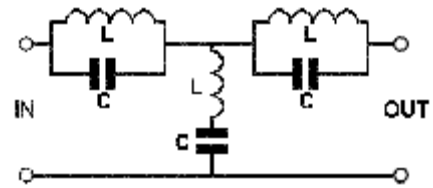

I.F. Transformers.

These are small transformers, used in radio and TV equipment to pass a band of radio frequencies from one stage of the intermediate frequency (IF) amplifiers, to the next. They have an adjustable core of compressed iron dust (Ferrite). The core is screwed into, or out of the windings forming a variable inductor.

This variable inductor, together with a fixed capacitor 'tunes' the transformer to the correct frequency. In older TV receivers a number of individually tuned IF transformers and adjustable filter circuits were used to obtain a special shape of pass band in a chain of amplifiers that amplify sound and vision signals. This practice has largely been replaced in modern receivers by packaged filters and SAW Filters.

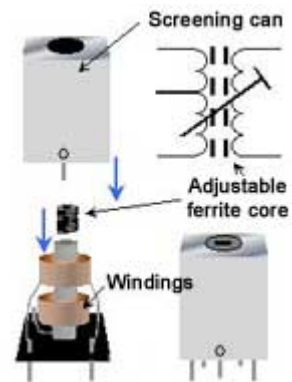

Packaged Filters.

There are thousands of filters listed in component catalogues, some using combinations of L C and R, but many making use of ceramic and crystal piezo-electric materials. These produce an a.c. electric voltage when they are mechanically vibrated, and they also vibrate when an a.c. voltage is applied to them. They are manufactured to resonate (vibrate) only at one particular, and very accurately controlled frequency and are used in applications such as band pass and band stop filters where a very narrow pass band is required. Similar designs (crystal resonators) are used in oscillators to control the frequency they produce, with great accuracy. One packaged filter in TV receivers can replace several conventional IF transformers and LC filters. Because they require no adjustment, the manufacture of RF (radio frequency) products such as radio, TV, mobile phones etc. is simplified and consequently lower in price. Sometimes however, packaged filters will be found to have an accompanying LC filter to reject frequencies at harmonics of their design frequency, which ceramic and crystal filters may fail to eliminate.

TV SAW Filter

The illustration (right) shows a Surface Acoustic Wave (SAW) IF (intermediate frequency) filter for PAL TV. SAW filters can be manufactured to either a very narrow pass band, or a very wide band with a complex (pass and stop) response to several different frequencies. They can produce several different signals of specific amplitudes at their output. Special TV types replace several LC tuned filters in modern TVs with a single filter. They work by creating acoustic waves on the surface of a crystal or tantalum substrate, produced by a pattern of electrodes arranged as parallel lines on the surface of the chip. The waves created by one set of transducers are sensed by another set of transducers designed to accept certain wavelengths and reject others. Saw filters are produced for many different products and have response curves tailored to the requirements of specific types of product.



Ceramic Filters

Ceramic filters are available in a number of specific frequencies, and use a tiny block of piezo electric ceramic material that will mechanically vibrate when an AC signal of the correct frequency is applied to an input transducer attached to the block. This vibration is

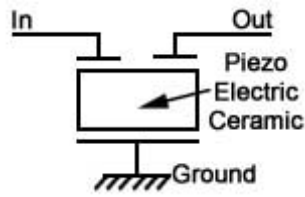

converted back into an electrical signal by an output transducer, so only signals of a limited range around the natural resonating frequency of the piezo electric block will pass through the filter. Ceramic filters tend to be cheaper, more robust and more accurate than traditional LC filters for applications at radio frequencies. They are supplied in different forms including surface mount types, and the encapsulated three-pin package shown here.

Module 8.2 How Filters Work.

CR Filter Operation.

Figs 8.2.1 and 8.2.2 show two common methods of using C and R together to achieve alterations in AC signals. These CR combinations are used for many purposes in a wide variety of circuits. This section describes their effects when used as filters with sine wave signals of varying frequencies. The same circuits are also used to change the shape of non-sinusoidal waves and this topic "Differentiation and Integration" is described in Section 8.4 and 8.5 of this module.

High Pass CR Filter

The CR circuit illustrated in Fig 8.2.1, when used with sinusoidal signals is called the HIGH PASS FILTER. Its purpose is to allow high frequency sine waves to pass unhindered from its input to its output, but to reduce the amplitude of, (to attenuate) lower frequency signals. A typical application of this circuit would be the correction of frequency response (tone correction) in an audio amplifier or tape recorder.

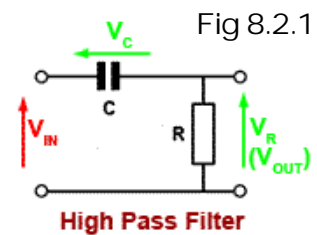

As described in Module 6 (Resistance and Reactance), resistance is constant at any frequency, but the opposition to current flow offered by the capacitor (C) however, is due to capacitive reactance X_C , which is greater at low frequencies than at high frequencies.

The reactance of the capacitor (X_C) and the resistance of the resistor (R) in fig 8.2.1 act as a potential divider placed across the input, with the output signal taken from the centre of the two components. At low frequencies where X_C is much greater than R, the share of the signal voltage across R will be less than that across C and so the output will be attenuated. At higher frequencies, it is arranged, by suitable choice of component values, that the resistance of R will be much greater than the (now low) reactance X_C , so the majority of the signal is developed across R, and little or no attenuation will occur.

Low Pass CR Filter

In Fig 8.2.2 the positions of the resistor and capacitor are reversed, so that at low frequencies the high reactance offered by the capacitor allows all, or almost all of the input signal to be developed as an output voltage across X_C . At higher frequencies however, X_C becomes much less than R and little of the input signal is now developed across X_C . The circuit therefore attenuates the higher frequencies applied to the input and acts as a LOW PASS FILTER.

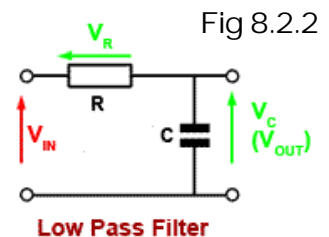

The band of frequencies attenuated by high and low pass filters depends on the values of the components. The frequency at which attenuation begins or ends can be selected by suitable component choices. In cases of audio tone correction, the resistor may be made variable, allowing a variable amount of bass or treble (low or high frequency) cut. This is the basis of most inexpensive tone controls.

High and low pass filters can also be constructed from L and R. In this case the action is the same as for the CR circuit except that the action of X_L is the reverse of X_C . Therefore in LR filters the position of the components is reversed.

Phase Change in Filters

The above description of high and low pass filters explains how they operate in terms of resistance and reactance. It shows how gain (V_{out}/V_{in}) is different at high and low frequencies due to the relative values of X_C and R . However this simple explanation does not take the phase relationships between capacitors or inductors, and resistors into account. To accurately calculate voltage values across the components of a filter it is necessary to take phase angles into consideration as well as resistance and reactance. This can be done by using phasor diagrams to calculate the values graphically, or by a branch of algebra using 'complex numbers' and 'j Notation'. However these calculations can also be done using little more than the Reactance calculations learned in Module 6 and the Impedance Triangle calculations from Module 7.

Problem:

Calculate the peak to peak voltages V_R appearing across R and V_C appearing across C when an AC supply voltage of $2V_{PP}$ at 1kHz is applied to the circuit as shown.

Note:

Although C and R form a potential divider across V_S it is not possible (because phase angles must also be taken into account) to calculate these values using the potential divider equation:

$$V_r = V_s \frac{R}{X_c + R}$$

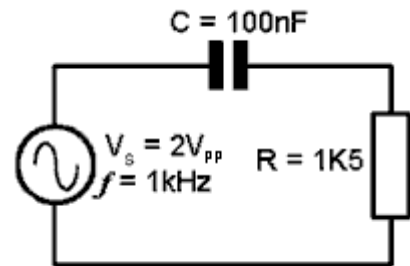

Follow these steps:

1. Find the value of capacitive reactance X_C using:

$$X_c = \frac{1}{2\pi f C}$$

$$X_c = \frac{1}{2\pi f C} = \frac{1}{2\pi \times 1 \times 10^3 \times 100 \times 10^{-9}} = 1591.5\Omega$$

2. Use the Impedance Triangle to find Z (the impedance of the whole circuit).

$$Z = \sqrt{R^2 + X_c^2}$$

$$Z = \sqrt{R^2 + X_c^2} \equiv Z = \sqrt{(1500^2 + 1591.5^2)} \equiv 2187\Omega$$

3. Knowing that the supply voltage V_S is developed across Z , the next step is to calculate the volts per ohm (V/Ω),

$$\frac{V_s}{Z} = \frac{2}{2187} = 914.5\mu V/\Omega$$

Contd.

Because the volts per ohm will be the same for each component as it is for the circuit impedance, the result from step 3 can now be used to find the voltages across C, and across R.

$$V_R = 1500 \times 914.5\mu\text{V}/\Omega = 1.37\text{V}$$

$$V_c = 1591.5 \times 914.5\mu\text{V}/\Omega = 1.45\text{V}$$

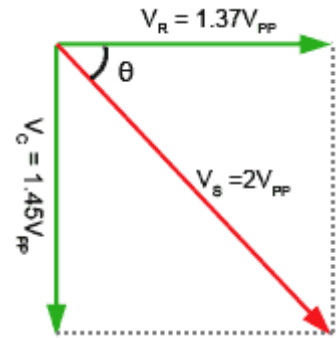

If required, the Phase angle θ could also be found using trigonometry as described in Phasor Calculations, Module 5.4 (Method 3). To find the angle θ (the phase difference between the supply voltage V_S and the supply current, which would be in the same phase as V_R) the two voltages already found could be used.

$$\text{Angle } \theta = \tan^{-1} \frac{\text{Opposite}}{\text{Adjacent}} = \tan^{-1} \frac{V_c}{V_R} = \tan^{-1} \frac{1.45}{1.37} = 46.6^\circ$$

Fig 8.2.3 demonstrates how phasor diagrams can explain both the amplitude and phase effects of a CR High Pass filter. Notice that it is the input voltage that apparently changes phase, but this is just because the circuit current phasor (and the V_R phasor) is used as the static reference phasor. The thing to remember is that there is a phase change of between 0° and 90° happening between V_{IN} and V_{OUT} , which depends on the frequency of the signal.

Fig 8.2.3

High Pass Filter Bode Plot

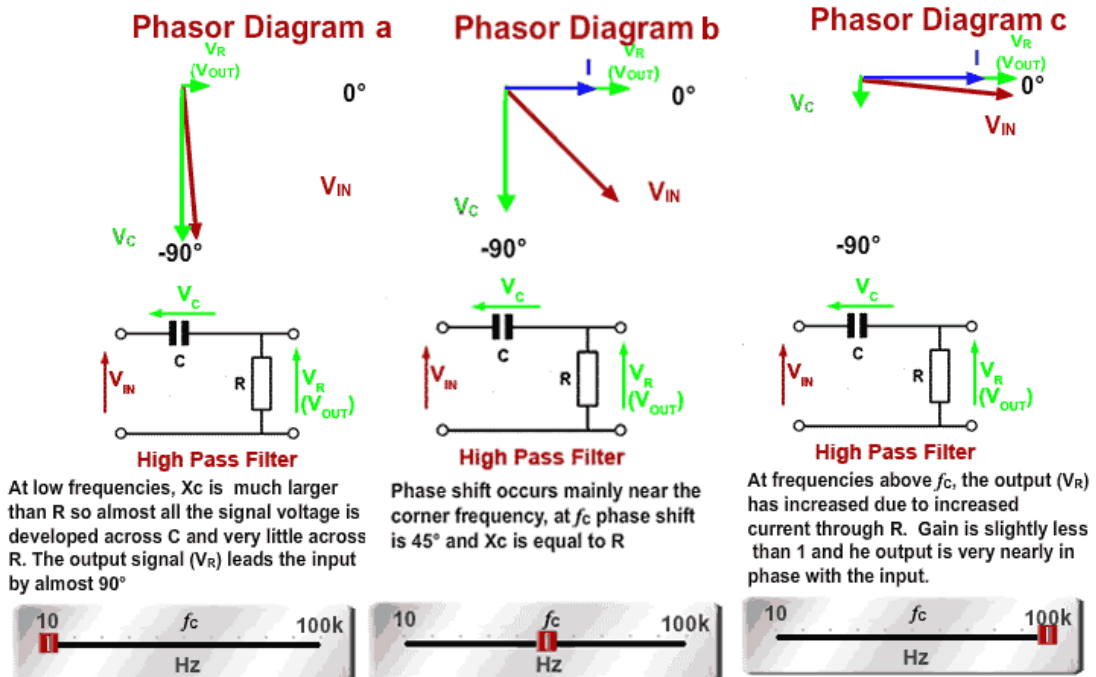
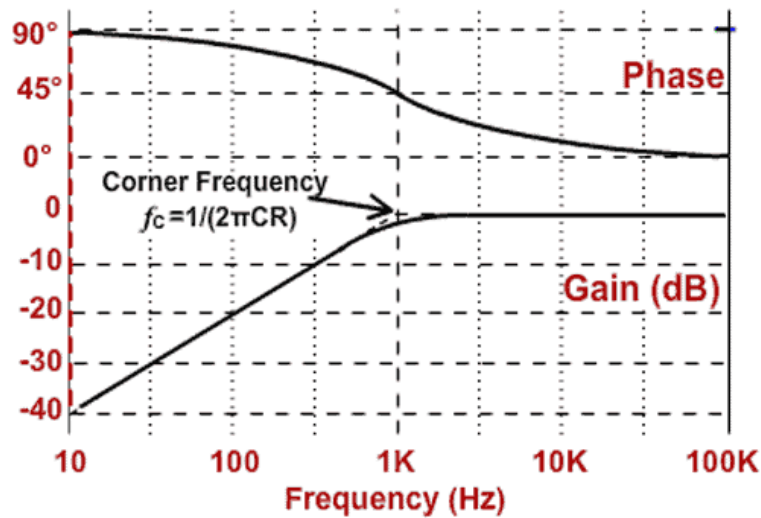

- At low frequencies the output V_{OUT} (V_R) is much smaller than V_{IN} (V_C) and a phase shift of up to 90° occurs with the output phase leading the input phase.
- At high frequencies there is little or no difference between the relative amplitudes of V_{OUT} (V_R) and V_{IN} (V_C), and little or no phase shift is taking place.

Fig 8.2.4 similarly demonstrates the action of a CR Low Pass Filter.

Fig 8.2.4

Low Pass Filter Bode Plot

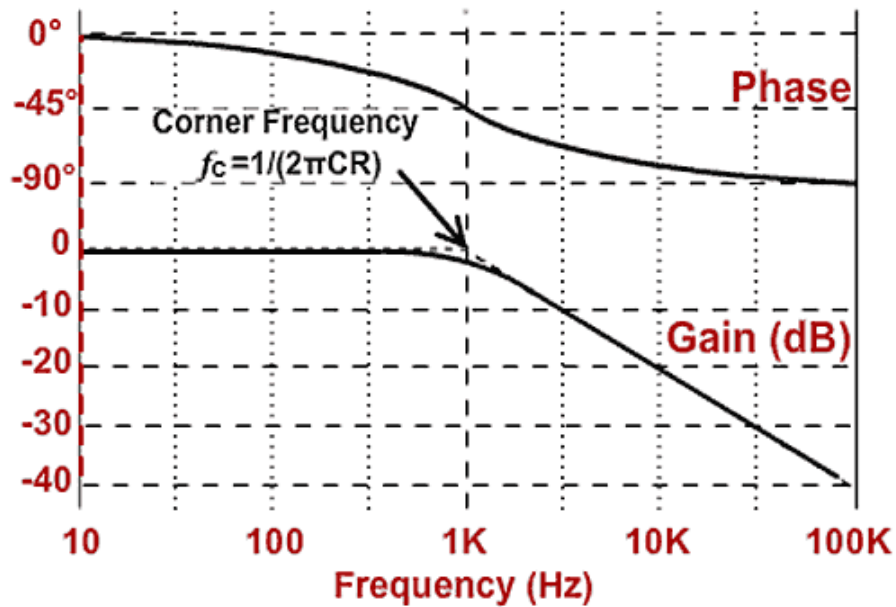

Phasor Diagram a

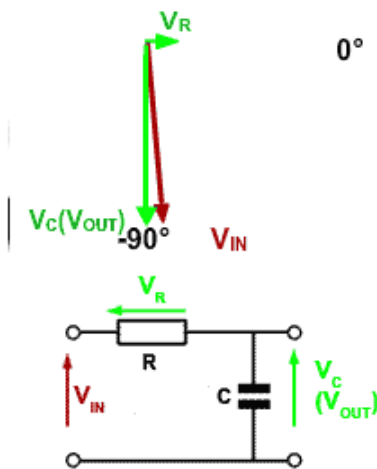

Low Pass Filter

At low frequencies, gain is slightly less than 1. The output is very nearly in phase with the input.

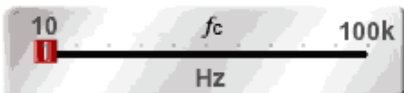

Phasor Diagram b

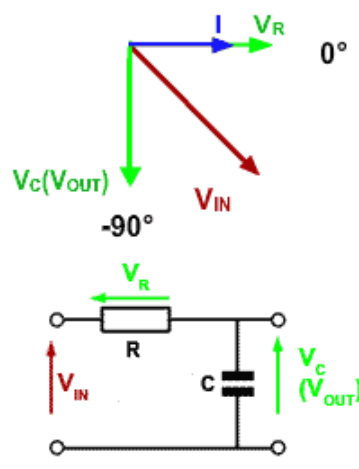

Low Pass Filter

Phase shift occurs mainly near the corner frequency, at f_c phase shift is 45° and X_c is equal to R .

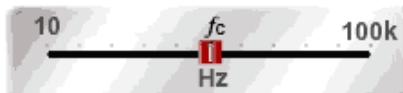

Phasor Diagram c

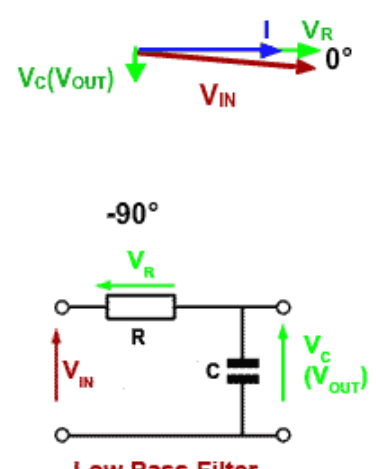

Low Pass Filter

Eventually, X_c has become much smaller than R so almost all the signal voltage is developed across R and very little across C . Phase shift approaches -90° .

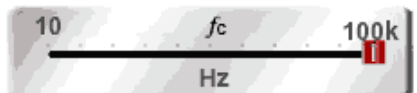

Module 8.3 Bode Plots

Showing Phase Shift and Attenuation

When considering the operation of filters, the two most important characteristics are:

- The FREQUENCY RESPONSE, which illustrates those frequencies that will, and will not be attenuated.
- The PHASE SHIFT created by the filter over its operating range of frequencies.

Bode Plots show both of these characteristics on a shared frequency scale making a comparison between the gain of the filter and the phase shift simple and accurate.

Fig 8.3.1 Bode Plot for a Low Pass Filter.

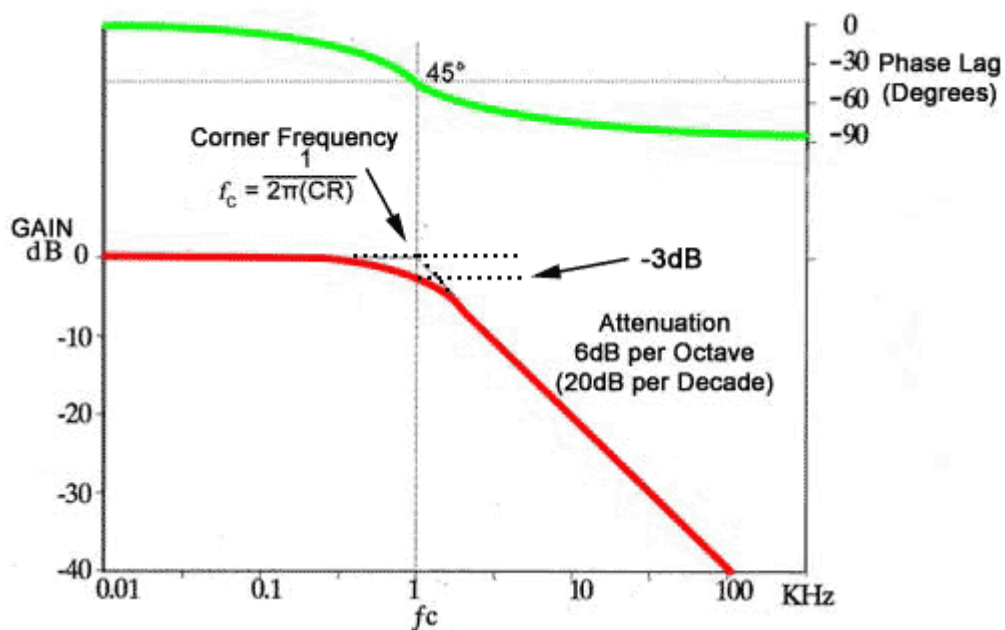

Frequency is plotted on the horizontal axis using a logarithmic scale, on which every equal division represents ten times the frequency scale of the previous division, this allows for a much wider range of frequency to be displayed on the graph than would be possible using a simple linear scale. Because the frequency scale increases in "Decades" (multiples of x10) it is also a convenient way to show the slope of the gain graph, which can be said to fall at 20dB per decade.

The vertical axis of the gain graph is marked off in equal divisions, but uses a logarithmic unit, the decibel (dB) to show the gain, which with simple passive filters is always unity (1) or less. The dB units therefore have negative values indicating that the output of the filter is always less than the input, (a gain of less than 1). The upper section of the vertical axis is plotted in degrees of phase change, varying between 0 and 90° or sometimes between -90° and +90°

A Bode plot for a low pass filter is shown in Fig 8.3.1. Note the point called the corner frequency. This is the approximate point at which the filter becomes effective. Frequencies below this point are unaffected by the filter, while above the corner frequency, attenuation of the signal increases at a constant rate of -6dB per octave. This means that the signal output voltage is halved (-6dB) for each doubling (an octave) of the input frequency.

Alternatively the same fall off in gain may be labelled as -20dB per decade, which means that the gain falls by ten times (to 1/10 of its previous value) for every decade (tenfold) increase in frequency, i.e. if the gain of the filter is 1 at a frequency of 1kHz, it will be 0.1 at 10kHz. The fall off in gain of a filter is

quite linear beginning from the corner frequency (also called the cut off frequency). This linear fall off in gain is common to both high and low pass filters, it is just the direction of the fall, increasing or decreasing with frequency, that is different.

The corner (or cut off) frequency (f_c) is where the active part of the gain plot begins, and the gain has fallen by -3dB . The phase lag of the output signal in a low pass filter (or phase lead in a high pass filter) is at 45° , exactly half way between its two possible extremes of 0° and 90° . The corner frequency may be calculated for any two values of C and R using the formula:

$$f_c = \frac{1}{2\pi CR}$$

For LR filters the formula is similar:

$$f_c = \frac{1}{2\pi LR}$$

Note that the corner frequency is that point where two straight lines representing the two sections of the graph either side of f_c would intersect. The actual curve makes a smooth transition between the horizontal and sloping sections of the graph and the gain of the filter is therefore -3dB at f_c .

8.4 Differentiators

Differentiation

Simple RC networks such as the high and low pass filters, when used with sine waves, do not alter the shape of the wave. The amplitude and phase of the wave may change, but the sine wave shape does not alter. If however, the input wave is not a sine wave but a complex wave, the effects of these simple circuits appears to be quite different. When using a square or triangular wave as the input, the RC High pass circuit produces a completely different shape of wave at the output.

The change in shape also depends on the frequency of the wave and on the circuit's component values. The various effects possible with a simple high pass RC filter can be summarised by Table 8.4.1.

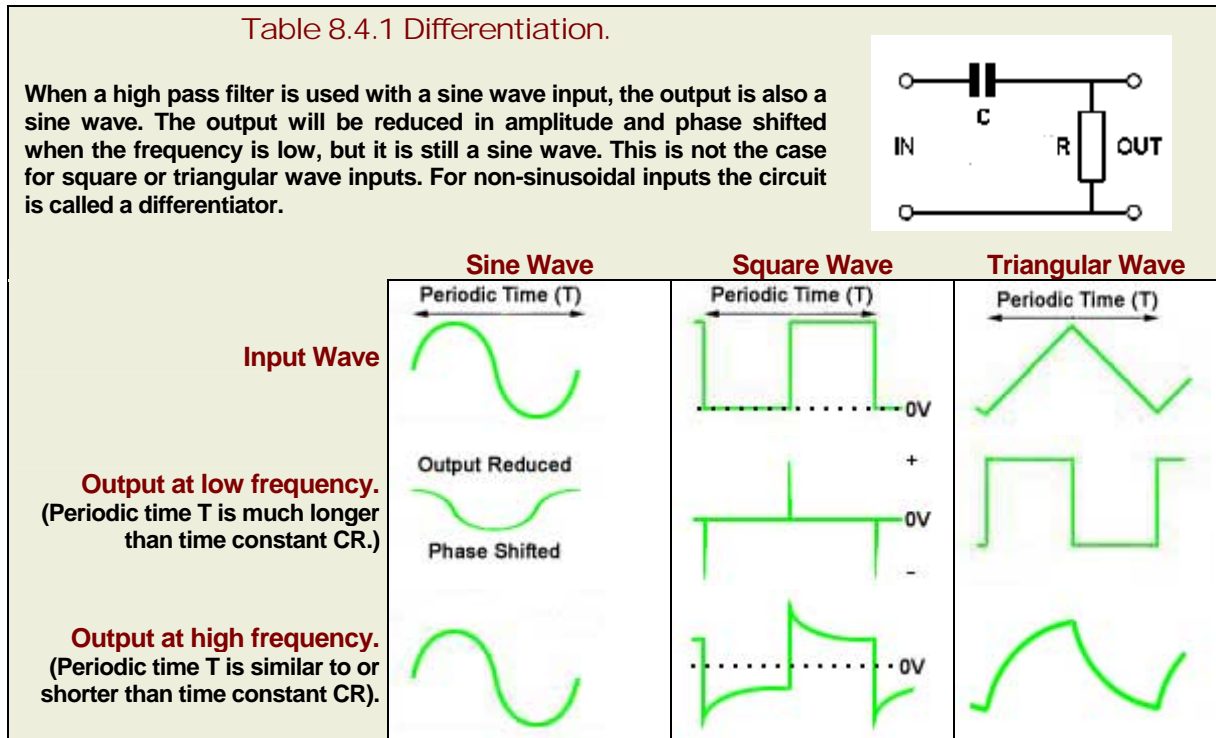

The Square Wave column in Fig 8.4.1 shows the differentiator action of a high pass filter. This happens when the time constant of the circuit (given by $C \times R$) is much shorter than the periodic time of the wave, and the input wave is non-sinusoidal. The output wave is now nothing like the input wave, but consists of narrow positive and negative spikes. The positive spike coincides in time with the rising edge of the input square wave. The negative spike of the output wave coincides with the falling, or negative going (towards zero volts) edge of the square wave.

The circuit is called a DIFFERENTIATOR because its effect is very similar to the mathematical function of differentiation, which means (mathematically) finding a value that depends on the RATE OF CHANGE of some quantity. The output wave of a DIFFERENTIATOR CIRCUIT is ideally a graph of the rate of change of the voltage at its input. Fig. 8.4.2 (overleaf) shows how the output of a differentiator relates to the rate of change of its input, and that actually the actions of the high pass filter and the differentiator are the same.

Fig 8.4.2 Differentiation.

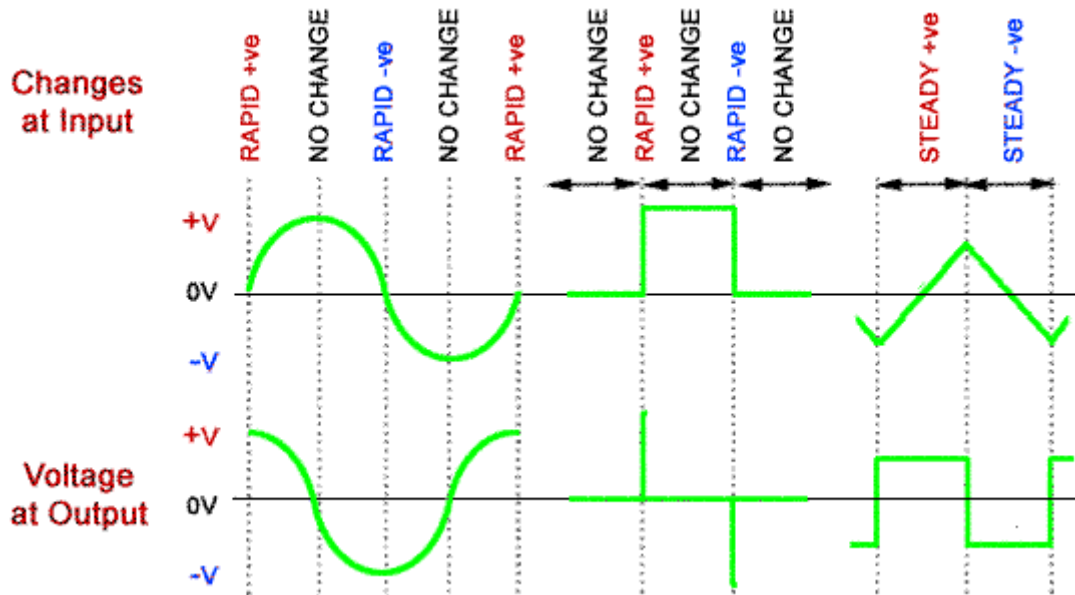

The differentiator output is effectively a graph of the rate of change of the input. Whenever the input is changing rapidly, a large voltage is produced at the output. The polarity of the output voltage depends on whether the input is changing in a positive or a negative DIRECTION.

A graph of the rate of change of a sine wave is another sine wave that has undergone a 90° phase shift (with the output wave leading the input wave).

A square wave input produces a series of positive and negative spikes coinciding with the rising and falling edges of the input wave.

A triangular wave has a steady positive going rate of change as the input voltage rises, so produces a steady positive voltage at the output. As the input voltage falls at a steady rate of change, a steady negative voltage appears at the output. The graph of the rate of change of a triangular wave is therefore a square wave. Wave shaping using a simple high pass filter or differentiator is a very widely used technique, used in many different electronic circuits. Although the ideal situation is shown here, how closely the output resembles perfect differentiation depends on the frequency (and periodic time) of the wave, and the time constant of the components used. In practice the result is usually somewhere between the two output waveforms shown for each input wave in Fig. 8.4.1

Module 8.5 Integrators

Integration

Integration in some ways is the opposite effect to differentiation. The shape of the input wave of an integrator circuit in many cases is a graph of the rate of change of the output wave. Fig. 8.5.1 shows the effects of integration on square, triangular and sine wave inputs. Notice that the circuit is that of the RC low pass filter. We use the name Integrator when;

- a. The input wave is not a sine wave, and
- b. The time constant of the circuit is much LONGER than the periodic time of the wave.

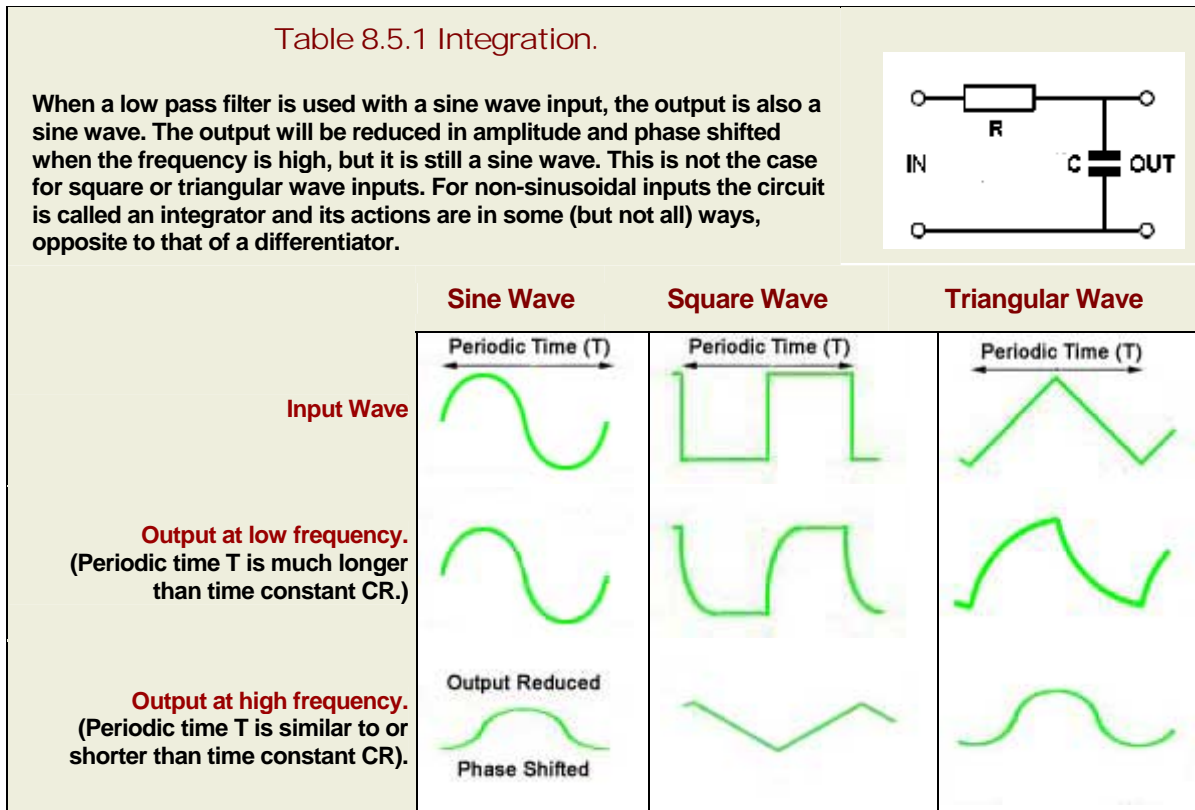

With the correct conditions of periodic time and time constant, integration takes place. The integrator has the opposite effect to the differentiator, the output should now be (if the input and output waves are considered as simple graphs rather than waveforms), a graph of the changing area beneath the input wave. For example, with a square wave input the output is a triangular wave, the slope of which describes the increase in area beneath the square wave (moving from left to right).

However, this theory seems to fall apart when the input is a triangular wave. The input seems to become a sine wave. This effect does not really fit with a theory of true mathematical integration. Remember however, that the integrator circuit is also a low pass filter, which has the effect of removing the higher frequency harmonics present in the complex (triangular) wave at its input.

If most of the higher frequencies in a complex wave such as a triangular wave are removed, this removes those harmonics that give the wave its shape; all that is left is the fundamental frequency, which is of course, a sine wave. In practice the integrator does remove many of the harmonics present in the input wave, but not all. Therefore the output wave is NEARLY a sine wave but slightly distorted, and the positive and negative half cycles are more nearly semi-circles than sine or cosine shapes.

If the input is a sine wave, the output is also a sine wave, but reduced in amplitude and lagging in phase on the input wave by 90 degrees, the identical (and not surprising) effect of the low pass filter.

Module 8.6 Filter Quiz

What you should know.

After studying Module 8, you should:

Be able to recognise typical filter circuits.

Be able to describe how passive filters work, and relate this to phasor diagrams.

Be able to describe Bode Plots and their uses.

Be able to describe the use of RC filters in wave shaping.

Try our quiz, based on the information you can find in Module 8. Submit your answers and see how many you get right, but don't be disappointed if you get answers wrong. Just follow the hints to find the right answer and learn about Filters and Wave Shaping Circuits as you go.

1.

Refer to Fig 8.6.1. What is this circuit called when used with sinusoidal signals?

- a) A high pass filter.
- b) A differentiator.
- c) A low pass filter.
- d) An integrator.

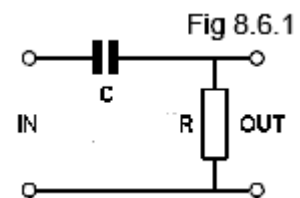

2.

With reference to Fig 8.6.2, which of the formulae would be used to find the corner frequency of a low pass filter?

- a) Formula a
- b) Formula b
- c) Formula c
- d) Formula d

Fig 8.6.2

$$f_c = \frac{1}{2\pi CL} \quad f_c = \frac{1}{2\pi CR}$$

a b

$$f_c = 2\pi CL^2 \quad f_c = 2\pi CR^2$$

c d

3.

Which of the following labels would most appropriately describe a High pass filter when used in an audio amplifier?

- a) Bass boost
- b) Bass cut
- c) Treble boost
- d) Treble cut

4.

With reference to Fig 8.6.3 what would be the approximate amplitude of the signal at the output?

- a) 1V
- b) 500mV
- c) 250mV
- d) 125mV

Fig 8.6.3

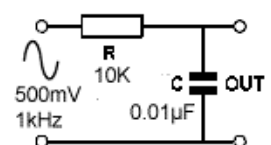

Continued

5.

Which of the following describes the circuit in Fig 8.6.4?

- a) Band stop filter
- b) Band pass filter
- c) High pass filter
- d) Low pass filter

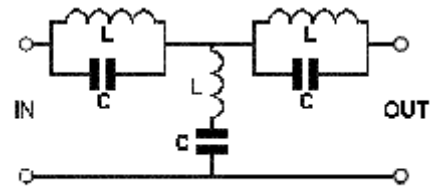

Fig 8.6.4

6.

What will be the waveform at the output of Fig 8.6.5?

- a) A rounded square wave
- b) Differentiated pulses
- c) A triangular wave
- d) A parabolic wave



Fig 8.6.5

7.

A square wave with a periodic time of $10\mu\text{s}$ is applied to the input of a differentiator circuit. For differentiated pulses to appear at the output, the time constant of the CR network should be approximately:

- a) $1\mu\text{s}$
- b) $2.5\mu\text{s}$
- c) $5\mu\text{s}$
- d) $10\mu\text{s}$

8.

Which of the following networks can be used as a differentiator?

- a) Notch filter
- b) High pass filter
- c) Band pass filter
- d) Band stop filter

9.

With reference to Fig 8.6.5, if a DC voltmeter is connected across the output terminals of the circuit with the input shown, what will be the voltmeter reading?

- a) 5V
- b) 2.5V
- c) 1.25V
- d) 0V

10.

With reference to Fig 8.6.6, if a triangular wave having a long time constant is applied to the input, what waveform would be expected at the output?

- a) A Square wave
- b) A triangular wave
- c) Differentiated pulses
- d) A sine wave

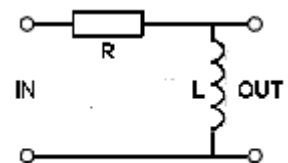

Fig 8.6.6