



are 4 choices for the exponent  $i$  and 3 choices for  $j$ . Hence there are  $4 \cdot 3 = 12$  divisors of 72. Reasoning similarly, we can see that for any integer

$$N = p_1^{e_1} p_2^{e_2} \cdots p_k^{e_k},$$

the number of divisors is

$$\prod_{i=1}^k (e_i + 1) = (e_1 + 1)(e_2 + 1) \cdots (e_k + 1).$$

### 3 Constructing the divisors of $N$

In part 1 we found the number of members of  $D_N$  for any positive integer  $N$ . In this part, we seek the list of divisors themselves. Again we start with the prime factorization of  $N$ . Suppose  $N = p_1^{e_1} p_2^{e_2} \cdots p_k^{e_k}$ . If  $k = 2$  the listing is straightforward. In this case, we build a table by first listing the powers of  $p_1$  across the top of the table and the powers of  $p_2$  down the side, thus obtaining an  $(e_1 + 1) \cdot (e_2 + 1)$  matrix of divisors. Again we use  $N = 72$  as an example. Notice that each entry in the table is the product of its row label and its column label.

	$2^0$	$2^1$	$2^2$	$2^3$
$3^0$	1	2	4	8
$3^1$	3	6	12	24
$3^2$	9	18	36	72

What do we do when the number of prime factors of  $N$  is more than 2? If  $k = 3$  we can construct  $e_3 + 1$  matrices of divisors, one for each power of  $p_3$ . For example, if  $N = 360 = 2^3 3^2 5$ , we construct one  $3 \times 4$  matrix for  $5^0$  and one for  $5^1$ . The result is a  $3 \times 4 \times 2$  matrix of divisors. The two  $3 \times 4$  matrices are shown below.

$5^0$	$2^0$	$2^1$	$2^2$	$2^3$	and	$5^1$	$2^0$	$2^1$	$2^2$	$2^3$
$3^0$	1	2	4	8		$3^0$	5	10	20	40
$3^1$	3	6	12	24		$3^1$	15	30	60	120
$3^2$	9	18	36	72		$3^2$	45	90	180	360

For larger values of  $k$  we can create multiple copies of the matrix associated with the number  $N = p_1^{e_1} p_2^{e_2} \cdots p_{k-1}^{e_{k-1}}$ .

### 4 The geometry of $D_N$

To investigate the geometry of  $D_N$ , we first explore the relation ‘divides’. Recall that  $a|b$  means that  $a$  and  $b$  are positive integers for which  $b/a$  is an integer. The relation ‘|’ has several important properties, three of which are crucial to our discussion.

1. Reflexivity. For any positive integer  $a$ ,  $a|a$ .
2. Antisymmetry. For any pair of positive integers  $a, b$ , if  $a|b$  and  $b|a$ , then  $a = b$ .
3. Transitivity. For any three positive integers,  $a, b, c$ , if  $a|b$  and  $b|c$ , then  $a|c$ .

These properties are easy to prove. The first says that each integer is a divisor of itself; that is,  $a/a$  is an integer. The second says that no two different integers can be divisors of one another. This is true since a larger integer can never be a divisor of a smaller one. The third property follows from the arithmetic  $b/a \cdot c/b = c/a$  together with the property that the product of two positive integers is a positive integer. Any set  $S$  with a relation  $\preceq$  defined on it that satisfies all three of the properties above is called a *partially ordered set*, or a *poset*. A branch of discrete mathematics studies the properties of posets,  $(S, \preceq)$ .

Each finite poset has a unique directed graph representation. This pictorial representation is what we mean by the geometry of  $D_N$ . To construct the directed graph of a poset  $(S, \preceq)$ , draw a vertex (dot) for each member of  $S$ . Then connect two vertices  $a$  and  $b$  with a directed edge (an arrow) if  $a \preceq b$ . Of course, in our case  $D_N$  this means we connect  $a$  to  $b$  if  $a|b$ . The case  $D_6$  is easy to draw:

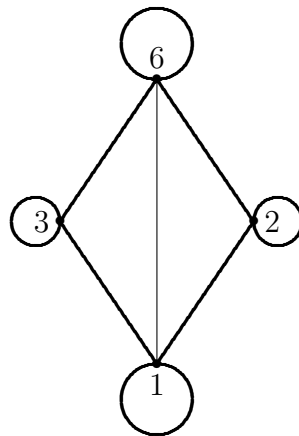

Fig. 1 The digraph of  $D_6$

The circles at each of the four vertices are called *loops*. They are included as directed edges because each number is a divisor of itself. The reader should imagine that all the non-loop edges are upwardly directed. The directed edge from 1 to 6 indicates that  $1|6$ . But since we know that the vertices of  $D_6$  satisfy all three properties required of a poset, we can leave off both (a) the loops, which are implied

by the reflexive property, and (b) the edges that are implied by the transitivity condition. The ‘slimmed down’ representation, called the Hasse diagram, is much easier to understand. It captures all the essential information without cluttering up the scene. The Hasse diagram of  $D_6$  is shown below.

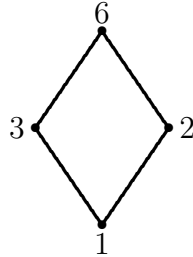

Fig. 2, the Hasse diagram of  $D_6$

In general, the Hasse diagram for  $D_N$  has only those non-loop edges which are not implied by transitivity, that is, those edges from  $a$  to  $b$  for which  $b$  is a prime number multiple of  $a$ . The Hasse diagrams of  $D_{72}$ ,  $D_{30}$ , and  $D_{60}$  are shown below.

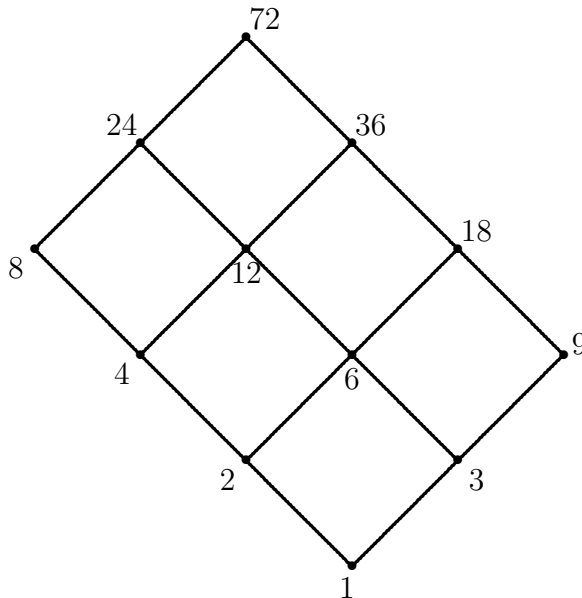

Fig. 3 The Hasse diagram of  $D_{72}$

Notice that each prime divisor of 30 can be considered a direction, multiplication by 2 moves us to the left ( $\nwarrow$ ), by 3 moves us upward ( $\uparrow$ ) and, by 5 moves us to the right ( $\nearrow$ ). Also note that if  $a$  and  $b$  are divisors of 30 then  $a|b$  if and only if there is a sequence of upwardly directed edges starting at  $a$  and ending at  $b$ . For example,  $1|30$  and  $(1, 3), (3, 15), (15, 30)$  are all directed edges in the digraph of  $D_{30}$ . On the other hand, we say 2 and 15 are incomparable because neither divides the other, and indeed there is no upwardly directed sequence of edges from either one to the other.

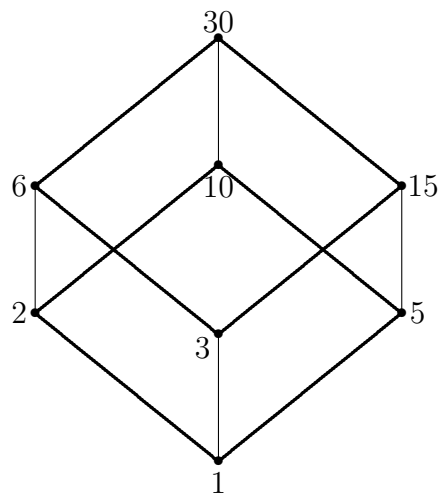

Fig. 4 The Hasse diagram of  $D_{30}$

What would the divisors of 60 look like if we build such a diagram for them? Try to construct it before you look at  $D_{60}$ .

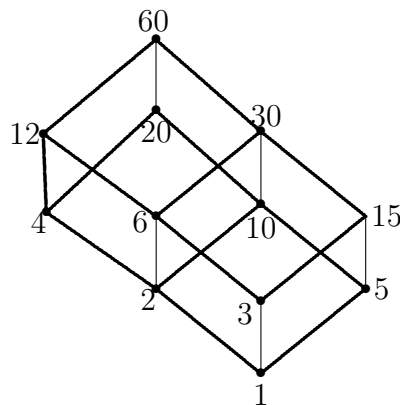

Fig. 5 The Hasse diagram of  $D_{60}$

Consider the same (lattice/Hasse) diagram for the divisors of 210. We can draw this in several ways. The first one (Fig. 6a) places each divisor of 210 at a level determined by its number of prime divisors. The second one (Fig. 6b) emphasizes the ‘degrees of freedom’. These two diagrams are representations of a four dimensional cube, not surprising since the Hasse diagram for  $D_{30}$  is a three-dimensional cube. A mathematical way to say the two digraphs are the same is to say they are *isomorphic*. This means that they have the same number of vertices and the same number of edges and that a correspondence between the vertices also serves as a correspondence between the edges. Note that the digraphs in 6a and 6b have the required number of vertices (16) and the required number of edges (32). Can you find an  $N$  such that the Hasse diagram of  $D_N$  is a representation of a five-dimensional cube? Such a digraph must have  $2^5 = 32$  vertices, and  $2 \cdot 32 + 16 = 80$  edges.

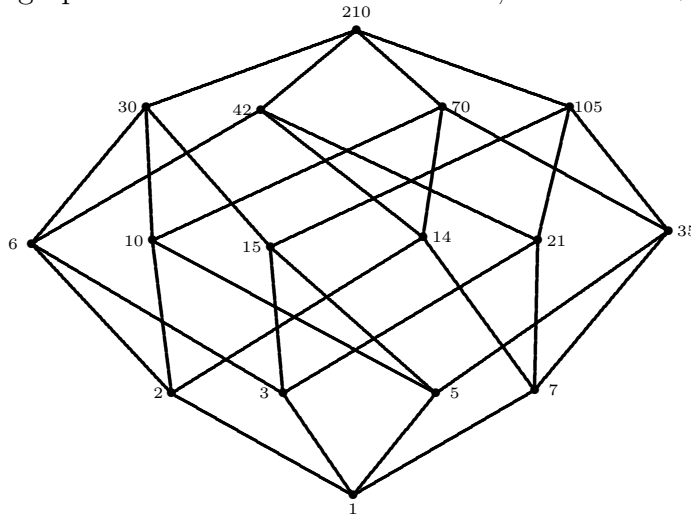

Fig 6a. The Hasse diagram of  $D_{210}$

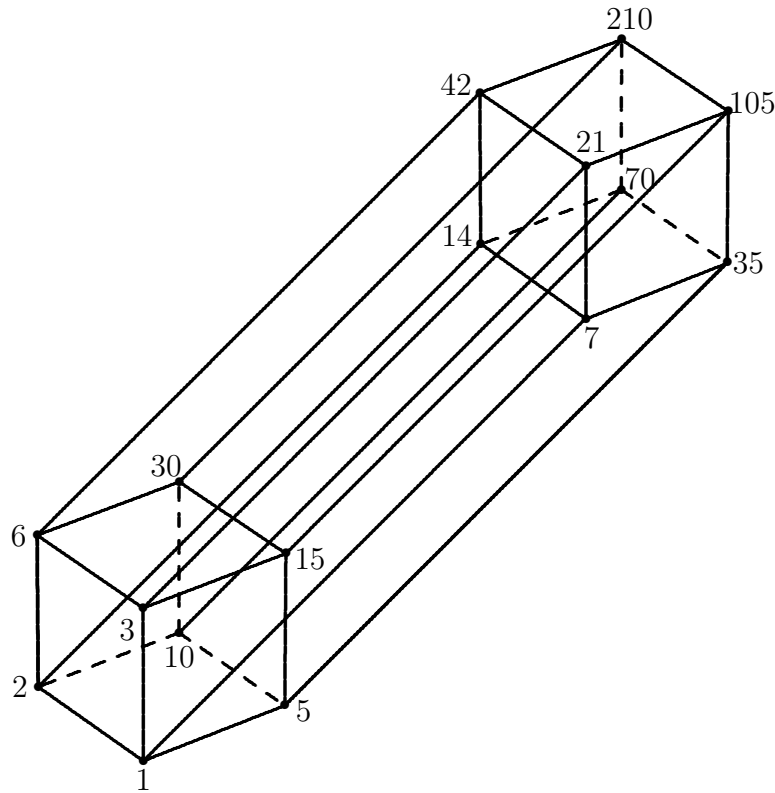

Fig 6b. The Hasse diagram of  $D_{210}$

How can the geometry help us do number theory? One way to use the geometry is

in the calculation of the *GCF* and *LCM* of two members of  $D_N$ . Note that each element  $d$  of  $D_N$  generates a downward ‘cone’ of divisors and an upward cone of multiples. We can denote these cones by  $F(d)$  and  $M(d)$  respectively. Then the  $GCF(d, e) = \max\{F(d) \cap F(e)\}$  and  $LCM(d, e) = \min\{M(d) \cap M(e)\}$ .

## 5 Problems On Divisors

Some of the following problems come from MathCounts and the American Mathematics Competitions.

1. Find the number of three digit divisors of 3600.
2. How many positive integers less than 50 have an odd number of positive integer divisors?
3. (The Locker Problem) A high school with 1000 lockers and 1000 students tries the following experiment. All lockers are initially closed. Then student number 1 opens all the lockers. Then student number 2 closes the even numbered lockers. Then student number 3 changes the status of all the lockers numbered with multiples of 3. This continues with each student changing the status of all the lockers which are numbered by multiples of his or her number. Which lockers are closed after all the 1000 students have done their jobs?
4. If  $N$  is the cube of a positive integer, which of the following could be the number of positive integer divisors of  $N$ ?  
(A) 200    (B) 201    (C) 202    (D) 203    (E) 204

5. Let

$$N = 69^5 + 5 \cdot 69^4 + 10 \cdot 69^3 + 10 \cdot 69^2 + 5 \cdot 69 + 1.$$

How many positive integers are factors of  $N$ ?

- (A) 3    (B) 5    (C) 69    (D) 125    (E) 216
6. A teacher rolls four dice and announces both the sum  $S$  and the product  $P$ . Students then try to determine the four dice values  $a, b, c$ , and  $d$ . Find an ordered pair  $(S, P)$  for which there is more than one set of possible values.
7. How many of the positive integer divisors of  $N = 2^3 \cdot 3^3 \cdot 5^3 \cdot 7^3 \cdot 11^3$  have exactly 12 positive integer divisors?
8. How many ordered pairs  $(x, y)$  of positive integers satisfy

$$xy + x + y = 199?$$

9. How many positive integers less than 400 have exactly 6 positive integer divisors?



10. The product of four distinct positive integers,  $a, b, c,$  and  $d$  is  $8!$ . The numbers also satisfy

$$ab + a + b = 391 \quad (1)$$

$$bc + b + c = 199. \quad (2)$$

What is  $d$ ?

11. How many multiples of 30 have exactly 30 divisors?
12. Find the number of odd divisors of  $13!$ .
13. Find the smallest positive integer with exactly 60 divisors.
14. (2008 Purple Comet) Find the smallest positive integer the product of whose digits is  $9!$ .
15. (1996 AHSME) If  $n$  is a positive integer such that  $2n$  has 28 positive divisors and  $3n$  has 30 positive divisors, then how many positive divisors does  $6n$  have?
16. Find the sum of all the divisors of  $N = 2^2 \cdot 3^3 \cdot 5^4$ .
17. (2010 Mathcounts Competition, Target 7) Find the product  $P$  of all the divisors of  $6^3$ , and express your answer in the form  $6^t$ , for some integer  $t$ .
18. Find the largest 10-digit number with distinct digits that is divisible by 11.
19. (This was problem 25 on the Sprint Round of the National MATHCOUNTS competition in 2011.) Each number in the set  $\{5, 9, 10, 13, 14, 18, 20, 21, 25, 29\}$  was obtained by adding two number from the set  $\{a, b, c, d, e\}$  where  $a < b < c < d < e$ . What is the value of  $c$ ?
20. (This was problem 8 on the Target Round of the National MATHCOUNTS competition in 2011.) How many positive integers less than 2011 cannot be expressed as the difference of the squares of two positive integers?
21. Consider the number  $N = 63000 = 2^3 \cdot 3^2 \cdot 5^3 \cdot 7$ .
- How many divisors does  $N$  have?
  - How many single digit divisors does  $N$  have?
  - How many two-digit divisors does  $N$  have?
  - How many three-digit divisors does  $N$  have?
  - How many four-digit divisors does  $N$  have?

- (f) How many five-digit divisors does  $N$  have?
22. The integer  $N$  has both 12 and 15 as divisors. Also,  $N$  has exactly 16 divisors. What is  $N$ ?
23. How many multiples of 30 have exactly 3 prime factors and exactly 60 factors.
24. How many whole numbers  $n$  satisfying  $100 \leq n \leq 1000$  have the same number of odd divisors as even divisors?
25. What is the sum of the digits in the decimal representation of  $N = \sqrt{25^{64} \cdot 64^{25}}$ ?
26. What is the fewest number of factors in the product  $27!$  that have to be removed so that the product of the remaining numbers is a perfect square?
27. Euclid asks his friends to guess the value of a positive integer  $n$  that he has chosen. Archimedes guesses that  $n$  is a multiple of 10. Euler guesses that  $n$  is a multiple of 12. Fermat guesses that  $n$  is a multiple of 15. Gauss guesses that  $n$  is a multiple of 18. Hilbert guesses that  $n$  is a multiple of 30. Exactly two of the guesses are correct. Which persons guessed correctly?