

# Smart Intelligent Computing and Communication Technology

Edited by  
V.D. Ambeth Kumar  
S. Malathi  
Valentina Emilia Balas  
Margarita Favorskaya  
Thinagaran Perumal



IOS Press

# Smart Intelligent Computing and Communication Technology

Recent developments in the fields of intelligent computing and communication have paved the way for the handling of current and upcoming problems and brought about significant technological advancements.

This book presents the proceedings of IConIC 2021, the 4th International Conference on Intelligent Computing, held on 26 and 27 March 2021 in Chennai, India. The principle objective of the annual IConIC conference is to provide an international scientific forum where participants can exchange innovative ideas in relevant fields and interact in depth through discussion with their peer group. The theme of the 2021 conference and this book is 'Smart Intelligent Computing and Communication Technology', and the 109 papers included here focus on the technological innovations and trendsetting initiatives in medicine, industry, education and security that are improving and optimizing business and technical processes and enabling inclusive growth. The papers are grouped under 2 headings: Evolution of Computing Intelligence; and Computing and Communication, and cover a broad range of intelligent-computing research and applications.

The book provides an overview of the cutting-edge developments and emerging areas of study in the technological fields of intelligent computing, and will be of interest to researchers and practitioners from both academia and industry.



ISBN 978-1-64368-202-0 (print)  
ISBN 978-1-64368-203-7 (online)  
ISSN 0927-5452 (print)  
ISSN 1879-808X (online)

SMART INTELLIGENT COMPUTING AND  
COMMUNICATION TECHNOLOGY

# Advances in Parallel Computing

Parallel processing is ubiquitous today, with applications ranging from mobile devices such as laptops, smart phones and in-car systems to creating Internet of Things (IoT) frameworks and High Performance and Large Scale Parallel Systems. The increasing expansion of the application domain of parallel computing, as well as the development and introduction of new technologies and methodologies are covered in the *Advances in Parallel Computing* book series. The series publishes research and development results on all aspects of parallel computing. Topics include one or more of the following:

- Parallel Computing systems for High Performance Computing (HPC) and High Throughput Computing (HTC), including Vector and Graphic (GPU) processors, clusters, heterogeneous systems, Grids, Clouds, Service Oriented Architectures (SOA), Internet of Things (IoT), etc.
- High Performance Networking (HPN)
- Performance Measurement
- Energy Saving (Green Computing) technologies
- System Software and Middleware for parallel systems
- Parallel Software Engineering
- Parallel Software Development Methodologies, Methods and Tools
- Parallel Algorithm design
- Application Software for all application fields, including scientific and engineering applications, data science, social and medical applications, etc.
- Neuromorphic computing
- Brain Inspired Computing (BIC)
- AI and (Deep) Learning, including Artificial Neural Networks (ANN)
- Quantum Computing

*Series Editor:*

Professor Dr. Gerhard R. Joubert

## Volume 38

*Recently published in this series*

- Vol. 37. D.J. Hemanth, V.D. Ambeth Kumar, S. Malathi (Eds.) Intelligent Systems and Computer Technology
- Vol. 36. I. Foster, G.R. Joubert, L. Kučera, W.E. Nagel and F. Peters (Eds.), Parallel Computing: Technology Trends
- Vol. 35. F. Xhafa and A.K. Sangaiah (Eds.), Advances in Edge Computing: Massive Parallel Processing and Applications
- Vol. 34. L. Grandinetti, G.R. Joubert, K. Michielsen, S.L. Mirtaheri, M. Taufer and R. Yokota (Eds.), Future Trends of HPC in a Disruptive Scenario

Volumes 1–14 published by Elsevier Science.

ISSN 0927-5452 (print)

ISSN 1879-808X (online)

# Smart Intelligent Computing and Communication Technology

Edited by

**V.D. Ambeth Kumar**

*Department of Computer Science and Engineering,  
Panimalar Engineering College, Chennai,  
Tamil Nadu, India*

**S. Malathi**

*Department of Computer Science and Engineering,  
Panimalar Engineering College, Chennai,  
Tamil Nadu, India*

**Valentina Emilia Balas**

*Department of Computer Science,  
"Aurel Vlaicu" University of Arad,  
Arad, Romania*

**Margarita Favorskaya**

*Department of Information Systems and Technologies,  
Reshetnev Siberian State University of Science and Technology,  
Krasnoyarsk, Russia*

and

**Thinagaran Perumal**

*Universiti Putra Malaysia, Malaysia*



**IOS Press**

Amsterdam • Berlin • Washington, DC

© 2021 The authors and IOS Press.

This book is published online with Open Access and distributed under the terms of the Creative Commons Attribution Non-Commercial License 4.0 (CC BY-NC 4.0).

ISBN 978-1-64368-202-0 (print)

ISBN 978-1-64368-203-7 (online)

Library of Congress Control Number: 2021946873

doi: 10.3233/APC38

*Publisher*

IOS Press BV

Nieuwe Hemweg 6B

1013 BG Amsterdam

Netherlands

fax: +31 20 687 0019

e-mail: [order@iospress.nl](mailto:order@iospress.nl)

*For book sales in the USA and Canada:*

IOS Press, Inc.

6751 Tepper Drive

Clifton, VA 20124

USA

Tel.: +1 703 830 6300

Fax: +1 703 830 2300

[sales@iospress.com](mailto:sales@iospress.com)

LEGAL NOTICE

The publisher is not responsible for the use which might be made of the following information.

PRINTED IN THE NETHERLANDS

# Preface

The book presents high-quality research papers presented in the 4th International conference, IConIC 2021, organized by Panimalar Engineering College, Chennai, Tamil Nadu, India on 26<sup>th</sup> and 27<sup>th</sup> March, 2021. The conference proceedings have a complete track record of the papers that are reviewed and presented at the conference. The principle objective is to provide an international scientific forum wherein the participants can mutually exchange their innovative ideas in relevant fields and interact in depth through discussion with peer groups. Both inward research as well as core areas of Intelligent Computing and its applications will be covered during these events. The aim of the proceedings is to provide cutting-edge developments taking place in the technological fields of Intelligent Computing which will assist the researchers and practitioners from both academia as well as industry to exchange, cross-fertilize their ideas and update knowledge in the latest developments and in the emerging areas of study. Researchers are now working in the relevant areas and the proceedings of IConIC 2021 plays a major role to accumulate those significant works in a single arena. The theme of the book ‘Smart Intelligent Computing and Communication Technology’ will focus on technological innovation and trendsetting initiatives applicable for corporate, industries, education, security to improve the business value, optimize business processes and enable inclusive growth, Proven IT governance, standards and practices that has led to the development in the form of prototype, design and tools to enable rapid information flow to the user. The book is divided into two parts namely: **“Evolution of Computing Intelligence”** and **“Computing and Communication”**.

The above parts will bring together the ideas, innovations and the experimental results of academicians, researchers and scientists in their domain of interest, in the areas of Intelligent Computing, Communication, and Control systems. The recent developments in the intelligent Computing and Communication paves the way for handling the current and upcoming problems thereby bringing a drastic change in the technological advancements. Furthermore, the newer and innovative ideas will be well groomed with adequate technical support and the core competent technical domains in Computing Intelligent Systems and Communication to improve the intellectual aspects. The conference looks for significant contributions towards the latest technologies in theoretical and practical aspects. Authors are solicited to contribute their experiences that describe significant advances in the following areas, but are not limited. It also provides a premier platform for Scientists, Researchers, Practitioners and Academicians to present and discuss about the most recent innovations, trends and concerns as well as practical challenges encountered in this field.

The Book Editors

Prof. V.D.Ambeth Kumar & Prof. Dr. S.Malathi  
Department of Computer Science and Engineering,  
Panimalar Engineering College, Chennai,  
Tamil Nadu, India

Prof. Valentina Emilia Balas,  
Department of Computer Science,  
“Aurel Vlaicu” University of Arad,  
Arad, Romania

Prof. Margarita Favorskaya,  
Department of Information Systems and Technologies,  
Reshetnev Siberian State University of Science and Technology,  
Krasnoyarsk, Russia

Prof. Dr. Thinagaran Perumal,  
Universiti Putra Malaysia, Malaysia



# Committees

## CHIEF PATRON

Dr. P. CHINNADURAI, M.A., Ph.D.,  
Secretary & Correspondent

## PATRONS

Mrs. C. VIJAYARAJESWARI,  
Director  
Dr. C. SAKTHIKUMAR, M.E., Ph.D.,  
Director  
Mrs.SARANYASREE SAKTHIKUMAR, B.E., M.B.A.,  
Director

## CO-PATRONS

Dr. K. MANI, M.E., Ph.D.,  
Principal

## CONVENER

Prof. Dr. S. MALATHI, M.E., Ph.D.,

## CO-CONVENER

Prof. Dr. V.D. AMBETH KUMAR., M.E., Ph.D.,

## ORGANIZING COMMITTEES

Prof. M. SUMITHRA,  
Prof. Dr. S. MAHESWARI,  
Prof. Dr.B.MUTHURAJ,  
Prof. Dr. D. SILAS STEPHEN.

## INTERNAL ADVISORY BOARD

Prof. Dr. P. KANNAN,  
Prof. Dr. S. MURUGAVALLI,  
Prof. Dr. M. HELDA MERCY,  
Prof. Dr. S. SELVI  
Prof. Dr. C. ESAKKIAPPAN,  
Prof. Dr. R.MANMOHAN,

**INTERNATIONAL ADVISORY BOARD**

Dr. VINCENZO PIURI, University of Milan, Italy  
 Dr. K.C. SANTOSH, University of South Dakota, USA  
 Dr. RAJKUMAR BUYYA, University of Melbourne, Victoria  
 Dr. PRASANTA K. GHOSH, Syracuse University, Syracuse  
 Dr. JAMES GELLER, New Jersey Institute of Technology, USA  
 Dr. CLAIRE MONTELEONI, George Washington University, USA  
 Dr. BRIAN BOROWSKI, Stevens Institute of Technology, USA  
 Dr. THOMAS AUGUSTINE, University of Colorado Denver, USA,  
 Dr. ELLEN GETHNER, University of Colorado Denver, USA  
 Dr. DIAB, MONA, George Washington University, USA  
 Dr. STEFANO BASAGNI, Northeastern University, USA  
 Dr. YASIR IBRAHIM, F.Engg, Jerash university, Jordan  
 Dr. YOUNG-BAE KO, Ajou University, South Korea  
 Dr. RIICHIRO MIZOGUCHI, Osaka University, Japan  
 Prof.SATTAR J. ABOUD, University of Bedfordshire, UK  
 Prof.Ir.Dr.Ab. HALIM BIN ABU BAKAR, University of Malaya, Malaysia  
 Dr. AKHTAR KALAM, Victoria University, Australia  
 Prof. Dr. SAAD MEKHILEF, University of Malaya, Malaysia  
 Dr. VARATHARAJU M. V, Ibra College of Technology, Oman  
 Dr. B. RAMPRIYA, Debre Markos University, Debre, Ethiopia  
 Dr. AHMED FAHEEM ZOBAA, Brunel University London, Uxbridge, UK  
 Dr. EASWARAMOORTHY RANGASWAMY, Amity University, Singapore  
 Dr. ANBALAGAN KRISHNAN, Xiamen University, Malaysia  
 Dr. SHANMUGAM JOGHEE, Skyline University College, Sharjah, UAE  
 Dr. J. PAULO DAVIM, University of Aveiro, Campus Santiago, Portugal  
 Dr. TALAL YUSAF, University of Southern Queensland, Australia  
 Dr. FEHIM FINDIK, Sakarya University, Turkey  
 Dr. A. S. SHAJA, Senior Data Scientist, Yodlee, California, USA  
 Dr. JUNZO WATADA, Waseda University, Wakamatsu , Japan  
 Dr. JONG HYUK PARK, Seoul Tech University, South Korea  
 Dr. ABDUL SATTAR, Director Griffith University, Australia  
 Dr. ANDREW JENNINGS, RMIT University, Melbourne, Australia  
 Dr. TAI-HOON KIM, Hannam University, Korea  
 Dr. DANIEL CHANDRAN, University of Technology, Sydney Australia  
 Dr. AMR TOLBA, KingsSaud University, Saudi Arabia  
 Dr. X. Z. GAO, Lappeenranta, University of Tech, Finland  
 Dr. LAI, Chang Gung University, Taiwan  
 Dr. DANIELLA GEORGE, University of Manchester, UK  
 Dr. YUAN CHEN, National University of Singapore  
 Dr. KAVEH OSTAD-ALI-ASKARI, Islamic Azad University, Iran  
 Dr. ADRIAN NICOLAE BRANGA, Ucian Blaga University of Sibiu, Romania

**NATIONAL ADVISORY BOARD**

Dr. SACHIN SHARMA, Graphic Era Deemed to be University, Uttarakhand  
 Dr. N.P. GOPALAN, National Institute of Technology, Tiruchirapalli

Dr. HARIGOVINDAN V P, National Institute of Technology Puducherry, Karaikal  
 Dr. LATA NAUTIYAL, Graphic Era University, Dehradun  
 Dr. H. HANNAH INBARANI, Periyar University, Salem  
 Dr. A. MUTHUMARI, University College of Engineering, Ramanathapuram  
 Dr. R. MURUGESWARI, Kalasalingam University, Tamil Nadu  
 Dr. JUDE HEMANTH, Karunya Institute of Technology and Sciences, Coimbatore  
 Dr. UJJWAL MAULIK, Jadavpur University, West Bengal  
 Dr. K. KUPPUSAMY, Alagappa University, Karaikudi  
 Dr. VIRENDER RANGA, NIT, Kurukshetra  
 Dr. A. GOVARDHAN, Jawaharlal Nehru Technological University, Hydrabad  
 Dr. S. PALANIVEL, Annamalai University, Chidambaram  
 Dr. NARENDRAN RAJAGOPALAN, NIT Puducherry  
 Dr. R. RAGUPATHY, Annamalai University, Chidambaram  
 Dr. S. SIVA SATHYA, Pondicherry University, Puducherry  
 Dr. JASMA BALASANGAMESHWARA, Atria Institute of Technology, Bangalore  
 Dr. M. RAMAKRISHNAN, Madurai Kamaraj University, Madurai  
 Dr. P. KARUPPANAN, NIT, Allahabad  
 Dr. P. SUMATHI, IIT, Roorkee  
 Dr. KALAISELVI J, IIT, Ropar  
 Dr. CHANDRASEKHAR, NIT, Hamirpur  
 Dr. P.SOMASUNDRAM, Anna University, Chennai  
 Dr. P. DEVADOSS MANOHARAN, College of Engineering, Guindy, Chennai  
 Dr. L. GANESAN, IIT Madras, Chennai  
 Dr. A. KANNAN, Anna University, Chennai  
 Dr. S. NIRMALA DEVI, Anna University, Chennai  
 Dr. K. SRIDHARAN, Anna University, Chennai  
 Dr. PRAKASH, Karpagam University, Coimbatore  
 Dr. S. PANDURANGAN, IIT Madras, Chennai  
 Dr. K. SELVAMANI, Anna University, Chennai  
 Dr. A. SURESH, NIET, Coimbatore  
 Dr. L.ARUN RAJ, Crescent Institute of and Science Technology, Chennai  
 Dr. K. RAMALAKSHMI, karunya Institute of Technology and Sciences, Coimbatore  
 Dr. R.VENKATESAN, karunya Institute of Technology and Sciences, Coimbatore  
 Dr. ARUN RAJ KUMAR, NIT, Puducherry  
 Dr. C. SWARNALATHA, Anna University, Madurai  
 Dr. K. PANNEERSELVAM, IGNOU, Kozhikode, Kerala  
 Dr. G. KUMARESAN, CEG, Anna University, Chennai  
 Dr. V. S. SENTHIL KUMAR, CEG, Anna University, Chennai  
 Dr. INDRA RAJASINGH, VIT University, Chennai  
 Dr. V. SANTHI, VIT University, Chennai  
 Dr. K. CHANDRASEKARAN, NITK, Mangalore  
 Prof. SIPRA DAS BIT, IEST, West Bengal  
 Dr. S. BHASKAR, Anna University, Chennai  
 Prof. UMA BHATTACHARYA, BESU, Howrah, West Bengal  
 Dr. S. AMALRAJ, Anna University, Chennai  
 Dr. G. RAVIKUMAR, Anna University, Chennai  
 Dr. K. MALATHI, CEG-AU, Chennai  
 Dr. M. GANESH MADHAN, MIT-AU, Chennai  
 Dr. E. LOGASHANMUGAM, Sathyabama University, Chennai

Dr. B. SHEELA RANI, Sathyabama University, Chennai  
Dr. D.B KSHIRSAGAR, Sanjivani College of Engineering, Maharashtra  
Dr.K.VENGATESAN, Sanjivani College of Engineering, Maharashtra

#### WEB DESIGN COMMITTEE

Prof. Mrs.R.PRIYA,  
Prof.Ms.K.PRIYANKA  
Prof. Mr.D.ELANGO VAN  
Mr.K.KEERTHIVASAN(PG Scholar)

#### PUBLICATION COMMITTEE

Prof.Dr.V.D.AMBETH KUMAR  
Prof.Mr.K.KAJENDRAN  
Ms.K.HARIPRIYA(PG Scholar)  
Ms.V.SRAVYA(PG Scholar)  
Ms.J.SUTHANTHARA RAJA PUSPHA(PG Scholar)

#### PROCEEDING COMMITTEE

Prof. Dr.K.VALARMATHI  
Prof. Mrs.M.SUMITHRA  
Prof. Dr. S. MAHESWARI  
Ms.Y.NISHA(PG Scholar)  
Ms.S.V.RUPHITHA(PG Scholar)  
Ms.A.KANCHANA DEVI(PG Scholar)  
Ms.A.NANDHINI DEVI(PG Scholar)

#### PUBLICITY COMMITTEE

Prof. Dr.S.SARASWATHI  
Prof. Ms.V.SATHYA PRIYA  
Ms.K.R.KAVYA(PG Scholar)  
Ms.P.HARITHA(PG Scholar)  
Ms.R.SUBHASHINI(PG Scholar)  
Ms.K.MALVIKA(PG Scholar)  
Ms.M.SWETHA(PG Scholar)  
Ms.S.PAVITHRA(PG Scholar)  
Ms.R.JEEVITHA(PG Scholar)

REGISTRATION COMMITTEE

Prof. Mrs.S.VIMALA  
Ms.M.INDHUMATHI(PG Scholar)  
Ms.D.MADHUBALA(PG Scholar)  
Mr.JUTRE VIJAY(PG Scholar)  
Ms.A.PREMI(PG Scholar)  
Ms.J.T.PREETHY SHIRLEY(PG Scholar)

FINANCE COMMITTEE

Prof. Dr.M.RAJENDIRAN  
Prof. H.MICKLE AANCY  
Prof. V.G. MURUGAN

This page intentionally left blank

# Contents

Preface	v
<i>V.D. Ambeth Kumar, S. Malathi, Valentina Emilia Balas, Margarita Favorskaya and Thinagan Perumal</i>	
Committees	vii
<b>Evolution of Computing Intelligence</b>	
A Novel Compression Algorithm Based on Bio-Orthogonal Transform and Encoding Methods for Computed Tomography Images	3
<i>R. Pandian, S LalithaKumari, V. AmalaRani, B. PrabhuDassBatvari and R. RajaKumar</i>	
Performance Analysis of K-Nearest Neighbor Classification Algorithms for Bank Loan Sectors	9
<i>Hemachandran K, Preetha Mary George, Raul V. Rodriguez, Raviraj M. Kulkarni and Sourav Roy</i>	
An Effective Comparative Analysis of Data Preprocessing Techniques in Network Intrusion Detection System Using Deep Neural Networks	14
<i>Aravind Prakash M, Indra Gandhi K, Sriram R and Amaysingh</i>	
Identification of Sickle Cells in Erythrocytes Images Using Shape Descriptors	20
<i>L. Yamini, R. Priyadharsini and A. Beulah</i>	
Impact of Personality Traits on Interpersonal Dependency	25
<i>S. Jainab Zareena and M. Krithika</i>	
Detection and Classification of Diseases in Cucumber Leaves	30
<i>RajaKumar.R, Pandian.R and PremJacob.T</i>	
Lane Detection and Tracking Algorithm Based on Curve Fitting Model	35
<i>Rajakumar.R, Pandian.R and PremJacob.T</i>	
Design and Analysis of Hybrid Classification Approaches Across Multi-Relational Decision Tree Learning Algorithm	41
<i>Tressa Michael</i>	
User Recommendation in OSN	47
<i>ChristiyanaArulselvi A, Sendhilkumar S and Mahalakshmi G S</i>	
Feasibility of Convolutional Neural Networks (CNN) for Content Based Image Retrieval of Images from Hadoop	52
<i>Muthiah.M.A, Logashanmugam.E and Nandhitha.N.M</i>	
Clinical Data Based Classification of Osteoporosis and Osteopenia Using Support Vector Machine	58
<i>Ramesh.T and Santhi.V</i>	

A Reliable Cloud Based Framework for Large Scale Urban Sensing Systems <i>K.R. Jansi, G.K. Sandhia and S.V. KasmirRaja</i>	67
Design of Prosthetic Arm <i>R. Swetha and S. NirmalaDevi</i>	73
I-Voting System Based on Block Chain <i>D. Jayashree, O. Pandithurai, S Yogeswari, K B Swetha and A. Shalini</i>	81
Deep Learning-Based Text Segmentation in NLP Using Fast Recurrent Neural Network with Bi-LSTM <i>Vinotheni.C and LakshmanaPandian.S</i>	87
Comparative Analysis Among Decision Tree vs. Naive Bayes for Prediction of Weather Prognostication <i>V. Sindhu and M. Prakash</i>	94
A Survey on Sports Video Annotation Frameworks <i>N. Chidambaram and G. Nallavan</i>	101
Decentralized Loan Management Application Using Smart Contracts on Block Chain <i>Arikumar K S, Deepak Kumar A, GowthamC and SahayaBeniPrathiba</i>	106
Feasibility of Infrared Thermography for Health Monitoring of Archeological Structures <i>N.M. Nandhitha, S. Emalda Roslin, Rekha Chakravarthi and M.S. Sangeetha</i>	111
Face Mask Detection Using CNN <i>SaiSupriya N, Priyanka, RashmiS and Parthasarathy G</i>	118
Study on Intelligent Data Algorithms Implemented in Wearable for Sports Applications <i>N. Nithya and G. Nallavan</i>	123
Evaluation of Existing Methods in Cervical Cancer Detection and Related Issues <i>Saravanan.M.S and A. Rajesh</i>	129
Survey on Food Recognition System Using Machine Learning <i>D. GaneshGaurav, Parthasarathy G, Dhananja, Chiranthan YC and KomalBharti</i>	134
Efficient Diagnosing Method for Heart Disease Using Deep Learning <i>Jayanthi S, Hajara FathimaS, IndiraniG and C.R. ReneRobin</i>	139
Anxiety Controlling Wrist Band <i>Shruthi S, Priya dharshini, Ranjith Raj B, Vaddi Lakshmi Satya Sai Sarojini, Ezhilarasi P and Rajesh Kannan S</i>	145
Vehicle License Plate Detection Using Bounding Box Technique <i>Vanitha N, Rene Robin C R, Doreen Hephzibah Miriam D and N SankarGanesh</i>	155
Discriminating Parkinson and Healthy People Using Machine Learning <i>S. Lakshmi, Manonmani.A, Jagadeeshwaran P, AkashS, JananiK and AkilandeswariD</i>	162



Predictive Analysis of Postpartum Haemorrhage Using Deep Learning Technique <i>S.V. Ruphitha and V.D. Ambeth Kumar</i>	168
A Comprehensive Survey on Privacy-Security and Scalability Solutions for Block Chain Technology <i>Puneeth R P and Parthasarathy G</i>	173
An Efficacious Text Summarization Process Using Triple Encoding-Decoding Mechanism <i>V.D. Ambeth Kumar, R. SubhaShini and K. Priyanka</i>	179
Facial Expression Recognition Under Occlusion Conditions Using ACNN <i>Balasundaram A, Ashokkumar S, Saravanan A, Sathish Kumar P J and Balaji S</i>	184
Intelligent Vehicle Scrutiny to Eradicate Malversation <i>Suthanthara Raja Pushpa J and Valarmathi K</i>	189
Cyber Bullying Scrutiny for Women Security in Social Media <i>Madhubala.D, Rajendiran. M, Elangovan.D and Priya.R</i>	194
Facilitation of Smart Car Assistant System Using IoT <i>M. Nithya, M.V.S. Soundarya Lahari, J.C.E Sai Sumitra and V. Lalitha</i>	199
Effective Early Stage Detection of COVID-19 Using Deep Learning <i>Swetha.M and Rajendiran. M</i>	204
IOT Based Weather Reporting System Using Arduino and Node MCU <i>Meera.S, Sharmikha Sree.R, Kalpana R.A, S.R. Manasvini, Haritha.V and K. Valarmathi</i>	209
Storage Optimization in Cloud Computing Using Discrete Firefly Algorithm to Minimize the Cost <i>Magesh Kumar S, Ahmed Mudassar Ali, Balasundaram A, P J Sathish Kumar and S Balaji</i>	214
Future Prediction of Cardiovascular Disease Using Deep Learning Technique <i>Indhumathi.M and V.D. Ambeth Kumar</i>	219
Detection of Malicious Web Applications Using Machine Learning Algorithm <i>Sivagurunathan M, Sivakumar P and Somasundaram. S K</i>	224
Story-Telling for Children in Image Processing Using Deep Learning – A Survey Review <i>P. Haritha, S. Vimala and S. Malathi</i>	229
Data Set Preparation Using the Method of Data Augmentation for Classification of Skin Diseases <i>Adlin Layola J.A and V. Murali Bhaskaran</i>	234
A Review Based on Secure Banking Application Against Server Attacks <i>Revathy P and Belshia Jebamalar G</i>	241
Attaining Cloud Security Solution Over Machine Learning Techniques <i>K. Muthulakshmi and K. Valarmathi</i>	246

Smart Shoe for Tracking and Monitoring of Army Soldiers <i>S.Jessica Pauline, Bharkavi A G, Annlet Jesgna and Maheswari S</i>	251
Efficient Face Mask Recognition System by Using Deep Learning Methodology <i>Hari Priya K and Malathi S</i>	256
Product Review Based on Machine Learning Algorithms <i>D. Elangovan and V. Subedha</i>	261
Delineation of Lung Tumor with Neural Networks <i>Kalpna R. A, Ganga A, Deepika R, Kiruthiga Devi M and Ramya N</i>	268
Detection and Identification of Pancreatic Cancer Using Probabilistic Neural Network <i>Ramya N, Manoj Kumar B, Vijay Balaji B, Kiruthiga Devi M and Deepika R</i>	273
Automatic Bridge Monitoring System Using IoT <i>SharmikhaSree.R, Meera.S, Deepika.R, DivyaS and Priyadarshini V S</i>	278
Detection of Body Movement for Comatose Patient Using IoT <i>Nisha.Y and K. Valarmathi</i>	283
Deciding Bank Client's Credit Limit and Home Loan Using Machine Learning <i>Ganga A, Vijayalakshmi S and Kalpana R A</i>	288
Detection of Ketosis in Bovine Using Machine Learning Techniques <i>Pushkala V and S. Nirmala Devi</i>	294
Underwater Image Enhancement and Fish Detection <i>I. Nelson, C. Annadurai, Shriram Venkatasubramani, Yogesh.I and Shrinivas Badri.S</i>	300
The Solution for XML External Entity Vulnerability in Web Application Security <i>Prabhakar.M and Abdul Raheem Syed</i>	305
An Analysis on Monitoring of Healthcare by Means of Internet of Things <i>Sathish N, Valarmathi K and Elangovan G</i>	311
A Robotic Assisted System Using Deep Learning for Navigation and Reading IoT Based Home Automation for Visually Impaired <i>Jayashree S, Jaswanthi R and Harshitha S V</i>	316
Deep Learning for Multi Grade Brain Tumor Classification in Smart Healthcare Systems: A Prospective Survey <i>Sravya V J and Malathi S</i>	321
Advanced Eyewear with Embedded Hardware for Woman Safety <i>Narendhiran.S, Radhakrishnan.P and Elangovan.D</i>	326
Intelligent Waste Classification System Using Vision Transformers <i>Menti Aditya Gowrish, Mukesh Kumar Dahlan and R. Subhashini</i>	331

## Computing and Communication

Experimental Investigation of Pulse Modulation Schemes in Free Space Optical Communication Under Turbulence	341
<i>Y.P. Arul Teen, NimmyLazer, J.M. Aravind and Rajesh K. B.</i>	
Bone Cancer Detection Using Feature Extraction with Classification Using K-Nearest Neighbor and Decision Tree Algorithm	347
<i>Satheesh Kumar, B and Sathiyaprasad. B</i>	
Implementation of IoT in Workplace Monitoring and Safety Systems	354
<i>C. Annadurai, I. Nelson, X.N. Ranald Nivethan, Suraj Vinod and M. Senthil Kumar</i>	
IoT Based Smart Energy Meter System Using Machine Learning	358
<i>I. Nelson, Annadurai. C, Ramya. E, Shivani. R and Mathusathana. V</i>	
Personalized CAPTCHA Using Cognitive Cryptography	363
<i>Radhika, Somasundaram.S K and Sivakumar.P</i>	
Enhancement of Routing Protocols for Mobile Adhoc Network	368
<i>Rajakumar.R, PandianR, PremJacob.T, Pravin.A and Indumathi.P</i>	
Comparative Study of Hybrid Optimizations Technique for On-Chip Interconnect in Multimedia SoCs	373
<i>Jayshree, Gopalakrishnan Seetharaman and Debadatta Pati</i>	
Analysis of Vedic, Wallace Tree and Array Multipliers	380
<i>G. Srividhya, D. Kalaiyarasi, N. Pritha and S.L. Bharathi</i>	
A Novel Approach to Evaluate Reduced Inter Symbol Interference in UFMC Systems	385
<i>Elavel Visuvanathan. G and Jaya. T</i>	
Topic Detection Using Multiple Semantic Spider Hunting Algorithm	390
<i>E. Elakiya, R. Kanagaraj and N. Rajkumar</i>	
FPGA Implementation of Protected Compact AES S-Box Using CQCG for Embedded Applications	396
<i>R. Sornalatha, N. Janakiraman, K. Balamurugan, Arun Kumar Sivaraman, Rajiv Vincent and A. Muralidhar</i>	
An Effective Denoising and Enhancement Strategy for Medical Image Using RI-GI-Caputo Method	402
<i>M. Ganga, N. Janakiraman, Arun Kumar Sivaraman, Rajiv Vincent, A. Muralidhar and Priya Ravindran</i>	
Design and Performance Analysis of Low Power High Speed Adder and Multiplier Using MTCMOS in 90nm, 70nm, 25nm and 18nm Regime	409
<i>Kalpana.K, Paulchamy. B, Priyadharsini. R, Arun Kumar Sivaraman, Rajiv Vincent, A. Muralidhar and Kong Fah Tee</i>	

Proficient Mining of Informative Gene from Microarray Gene Expression Dataset Using Machine Intelligence <i>Priya Ravindran, S. Jayanthi, Arun Kumar Sivaraman, Dhanalakshmi R, A. Muralidhar and Rajiv Vincent</i>	417
Balanced and Energy Efficient Multi Core-Aware Virtual Machine Placement Algorithm Using Multi-Dimensional Resource Space Partition Model <i>Nagadevi and Kasmir Raja</i>	423
LoRaWAN Based Manhole Cover Monitoring System <i>Aman Kumar Tiwari, Priyanka Chaudhari, Shardul Pattewar and Rohini Deshmukh</i>	429
Li-Fi & Wi-Fi Based Drone for Weather Monitoring with Data Storage in Cloud Using IoT <i>Jayashree T R, Priyadarshini K and K. Sri Harini</i>	434
MRI Brain Abnormality Detection Using Conventional Neural Network (CNN) <i>Jeevitha R and Selvaraj D</i>	439
Investigation and Suppression of RF Leakage Power in Front End Wireless Devices <i>Kanchana Devi A and Bhuvaneshwari B</i>	444
Smart Industry Monitoring and Controlling System Using IoT <i>Elumalai. G, Nallavan. G and Ramakrishnan. R</i>	449
Design of Compact Branch Line Coupler <i>Vijay Jutru and Maheswari S</i>	454
Hand Movement Based Message Transmission and Body Physical Parameters Remote Monitoring Device for Disabled People <i>D Kalaiyarasi, Shruthi. V, VishnuPraba.A and Vanaja.S</i>	459
Improvement of Multipath Channel Performance for Optical MIMO-OFDM in LED Modulation with Fully Generalized Spatial-Frequency <i>Nandhini Devi R, Leones Sherwin VimalrajS and Lydia J</i>	464
Radio Resource Allocation and Mobility Accessment of 5G Wireless Network Using Adaptive Q-LEACH Routing Protocol <i>Premi.A and Rajakumar.S</i>	469
Low Power, High Speed MUX Based Area Efficient Dadda Multiplier <i>Kalaiyarasi.D, Pritha.N, Srividhya.G and Padmapriya.D</i>	474
An Extended Mondrian Algorithm – XMondrian to Protect Identity Disclosure <i>R. Padmaja and V. Santhi</i>	480
Factual Question Generation System Using Pro Semantic Ranker <i>J Dafni Rose, U Sakthi and S S Ajithkumar</i>	491
Improved Linearly Constrained Minimum Variance Algorithm for 5G Communications System <i>Kaviya K R and Deepa S</i>	496

A Generic System for Processing Insurance <i>Samundeswari S, Jeshoorin G and Vasanth M</i>	501
A Survey on HetNet to Enhance QoS in 5G Network Using Various Techniques <i>Lydia Sharon Rose G and Ameelia Roseline A</i>	506
A Contemporary Survey on Low Power, High Speed Comparators for Bio-Medical Applications <i>R. Rajalakshmi, M. Janaki Rani and M. Anand</i>	511
5G Wireless/Wired Convergence of UPMC Based Modulation for Intensity Modulation Direct Detection <i>Keerthivasan K and Shibu S</i>	517
Study of Microstrip Dual-Band Band Pass Filter <i>Anciline V and Maheswari S</i>	522
Wireless Charger for Artificial Pacemaker <i>Abinaya.B, Abirami.A.P, Divya.J and Rajalakshmi.R</i>	527
Accident Prevention Black-Box and Vehicle-to-Vehicle Communication Using Li-Fi and Wi-Fi Technologies <i>Aishwarya I, Carolin B, ChalceEbenS and P. Kannan</i>	532
Vision Atrophy Screening and Revelation <i>Kiruthiga Devi M, Lingamuthu K, Baskar M, Deepa B and Merlin G</i>	537
Scraping and Analysing YouTube Trending Videos for BI <i>Sowmiya K, Supriya S and R. Subhashini</i>	542
AR Guide for Food Allergic Consumers <i>Karthika. S, Varsha.G and Deepika. R</i>	548
APMFT: Anamoly Prediction Model for Financial Transactions Using Learning Methods in Machine Learning and Deep Learning <i>R. Priyadarshini, K. Anuratha, N. Rajendran and S. Sujeetha</i>	553
Enhanced and Efficient Carry Select Adder with Minimal Delay <i>G. Srividhya, T. Sivasakthi, R. Srivarshini, P. Varshaa and S. Vijayalakshmi</i>	558
Customer Loan Approval Prediction Using Logistic Regression <i>Mahankali Gopinath, K. Srinivas Shankar Maheep and R. Sethuraman</i>	563
Smart Security System Using IoT, Face Recognition and Processor to Processor Communication <i>Indhuja G, Aashika V, Anusha K, Dhivya S and Meha Soman S</i>	570
Drowsiness Detection using CNN <i>Sheela. S, Jothika. D. E, Swarnapriya. N and Vishali. B. R</i>	575
Brain Tumor Detection Using Gray Level Co-Occurrence Matrix Feature Extraction Technique <i>SheelaS, R. Prema, S. Ramya and B. Thirumahal</i>	580

Role of Digital Marketing Data Analytics in Film Industry: Telugu Cinema into Pan India Magnum Opus <i>Janardhan Juvvigunta, Gondi Surender Dhanunjay, Adesh Kumar, Manoj Kumar Padhy, Abhishek Kumar and Pranjal Singh</i>	586
Tomato Leaf Disease Detection Using Hybrid CNN-RNN Model <i>Hepzibah Elizabeth David, K. Ramalakshmi, R. Venkatesan and G. Hemalatha</i>	593
An Analysis of the Applications of Natural Language Processing in Various Sectors <i>Priya B, Nandhini J.M and Gnanasekaran T</i>	598
Malicious Attack Identification Using Deep Non Linear Bag-of-Words (FAI-DLB) <i>E. Arul, A. Punidha, K. Gunasekaran, P Radhakrishnan and VD Ashok Kumar</i>	603
Detection of Network Attacks Based on Multiprocessing and Trace Back Methods <i>Vijayakumar R, Vijay K, Sivaranjani P and Priya V</i>	608
MRI Image Classification of Brain Tumor Using Deep Neural Network and Deployment using Web Framework <i>Sumithra M, Shruthi S, SmithiRam, Swathi S and Deepika T</i>	614
Subject Index	619
Author Index	625

# Evolution of Computing Intelligence

This page intentionally left blank



# A Novel Compression Algorithm Based on Bio-Orthogonal Transform and Encoding Methods for Computed Tomography Images

R.Pandian<sup>a,1</sup>, S LalithaKumari<sup>b</sup>, V.AmalaRani<sup>b</sup>, B.PrabhuDassBatvari<sup>b</sup> and R. RajaKumar<sup>c</sup>

<sup>a,1,b</sup>Associate Professor, Sathyabama Institute of Science and Technology, Chennai, Tamil Nadu

<sup>c</sup>Professor, Sathyabama Institute of Science and Technology, Chennai

**Abstract:** Image compression is the processing of images by using Transform operations and Encoding techniques. Nowadays, there is an essential need of these methods in the medical field. This work is focused on the performance quality assessment of medical images using Image Compression Techniques. Image compression is the process of compression of an image in such a way that it has less space than the original image. It is an organization of compression technique that reduces the size of an image file without affecting its quality to a greater extent. The bio-orthogonal transform is used for decomposing the Lung images. After decomposition, different methods of encoding are performed and finally the proposed compression methods are evaluated for finding optimum algorithm for medical image.

**Keywords:** Wavelet, Encoding, FT, FFT, SPIHT, EZW and STW.

## 1. Introduction

Image processing assumes a significant part in the fields like medicine, machine vision and example acknowledgment. The each piece of data is an image that is required in future for performing errands like arrangement, recovery and acknowledgment. The image compression is important to keep transmission capacity and save memory space. The computerized images are frequently characterized into varying sorts e.g double, dim scale, shading, bogus - shading, multispectral and thematic[1],[2].The change configuration might be a refinement of the two-sided separating strategy which contemplates the likeliness of shading pixels and their fleeting reach. The middle channel is very proficient in eliminating

---

<sup>1</sup>Pandian R , Associate professor, Dept of ECE, Sathyabama Institute of Science and Technology  
Email:rpandianme@gmail.com

Imprudent commotion, but its presentation is reduced when the image is slanted by Gaussian clamor and henceforth the VMF is normally matched with other separating arrangements in such a circumstance. This methodology focuses on a semi-nearby normal of the image pixels in such a way that the images can be safeguarded. The new pixel esteem is estimated as a weighted normal of the pixels which particular district is near the precarious edge of the pixel's nearby area that is being dissected. Regardless, the conventional channel applications normally obscure level inclinations inside the outcomes which can adversely influence ensuing transformations that mutilate the exact lines of the correlative constructions. The restriction of the above customary de-noising approaches frequently takes place in climate processing. To disentangle this issue, a few seismologists have followed the kind of edge-saving strategy which used in advanced image investigation.

It is shown from different trials that such a framework can productively eliminate the clamor while holding solid inclinations. According to literature overview, this work is engaged to address the compression algorithms by bio-symmetrical transform. The paper is organized as follows. In section 2 discusses how arrangements are done with the Image data base and section 3 clearly explains about the wavelet Transform. The results are discussed in section 4 and the exploration work is concluded in section 5.

## 2. Image Database

The prepared computed tomography of a lung considered in this work resembles the developed x-radiates using a couple of pictures or photographs that shows the internal organs of the human. The standard lung pictures are taken into account for depicting the threats in lung. An illustration of common place and threatening development affected CT pictures are shown in Figure 1. The pictures used for testing the estimations made are clinical pictures. In this work, medical images like the normal CT lung pictures and a threat impacted CT lung pictures taken from ten persons of a social class in DICOM design are used to depict the lung infection. The image data for this investigation work is amassed as conventional and strange pictures. The typical lung pictures are shown in Figure 1. The CT Lung pictures are gathered from Sathyabama Institute of science and Technology hospital, Chennai, TamilNadu.



**Figure 1.**Normal Lung coronal view



(FFT) in image investigation is that the nonappearance of worldly data. The brief time frame that the Fourier changes (STFT) confines time by moving time window. However, the fixed width is kept as far as possible at the high- recurrence run. The wavelet changes permit the segments of a non-fixed sign to be investigated, permit channels to be built for both fixed and non-fixed signals and have a window whose transmission capacity shifts in reference to the recurrence of the wavelet.[5]. It clarifies a full decay of the image was done to measure wavelet coefficients was an equal on the grounds that of the primary image and can be recombined to recreate the most image. It is accepted that wavelet investigation can assume a serious part in pressure research for diagnostics device.[6]. The Wavelet Transform is a broadly received strategy for pressure. The Essential pressure plot during this strategy is actualized inside the accompanying request relationship, quantization and encoding. DCT and DWT are documented, the changes are used to relate the pixels. The wavelet change deteriorates the image into various recurrence sub groups, to be specific lower recurrence sub groups and better recurrence sub groups by which smooth varieties and subtleties of the image are frequently isolated. The bulk of the energy is compacted into lower recurrence subgroups[7].The greater part of the coefficients in higher recurrence sub groups are little or zero and have a twisted to be assembled and furthermore are situated inside an identical relative spatial inside the sub groups. Hence, pressure strategies utilize wavelet changes which are effective in giving high paces of pressure while maintaining great image quality and are better than DCT-based techniques. In DCT, an outsized portion of the energy is compacted into lower recurrence coefficients to quantization, the overwhelming majority of the upper recurrence coefficient become little or zero and have a twisted to be assembled.[8]

The LL sub bands are frequently additionally disintegrated for ensuing degree of decay. On the off chance, that the degree of disintegration expands, the higher subtleties are caught more effectively [9]. The image subtleties are pressed into a little number of coefficients which are decreased to less number by following a quantization. The blunder or misfortune in data is on account of the quantization step. In this work, bio-orthogonal is used for decomposing the lung images for various vanishing moments. The performances are measured by vanishing moments for different encoder like SPIHT, EZW an STW [10] [11].

#### 4. Results and Discussions

The decomposition levels and vanishing moments are analyzed based on MSE, PSNR compression ratio and Bits per pixel. From the Table.1, the quality of compression evaluated by PSNR and amount of compression measured by MSE. The performance of compression using Biorthogonal Transform with five encoding methods for various vanishing moments such as 1.1,1.3,1.5.1.7and 1.9 with various decomposition levels are shown in Table 1

**Table 1.** Performance evaluation of Compression Algorithms

<b>Transform Type</b>	<b>Encod</b>	<b>PSNR</b>	<b>CR(%)</b>	<b>BPP</b>	<b>MSE</b>
Bior 1.3 with level1	SPIHT	42.14	67.02	17.05	5.01
	EZW	86.02	89.2	25.02	0.03
	STW	61.02	86.06	21.08	0.02
Bior 1.3 with level2	SPIHT	41.54	66.07	15.85	4.56
	EZW	64.57	88.70	21.28	0.02
	STW	55.23	85	20.39	0.19
Bior 1.3 with level3	SPIHT	40.35	39.58	9.49	6
	EZW	52.10	76.09	18.26	0.41
	STW	46.08	59.08	14.18	1.61
Bior 1.3 with level4	SPIHT	36.41	20.97	5.03	14.87
	EZW	44.79	51.85	12.44	2.16
	STW	38.42	31.23	7.5	9.4
Bior 1.5 with level1	SPIHT	41.02	66.58	16.81	5.58
	EZW	82.9	89.12	23.8	0.4
	STW	60.08	85.78	22.02	0.02
Bior 1.5 with level2	SPIHT	40.75	66.31	15.91	5.47
	EZW	63.83	89.48	21.48	0.03
	STW	54.85	85.56	20.53	0.21
Bior 1.5 with level3	EZW	43.62	52.53	11.94	1.97
	STW	46.14	60.2	15.28	2.01
	SPIHT	37.01	22.12	6.01	13.58
	EZW	37.57	29.80	7.01	9.56
	STW	39.15	33.32	7.26	9.12

## 5. Conclusion

A high amount of compression is achieved by Bio-orthogonal Transform with Encoding methods. The original image and compressed images are evaluated pixel by pixel. It is found that the compressed image will give more information. If the number of vanishing moments are increased, the quality of image is almost same. The bpp of the proposed calculations are additionally practically of same worth. It is apparent from the outcomes that the idea of the mother wavelets is the reason for the adjustment in the presentation esteems. The results obviously uncover that the quantity of evaporating minutes likewise assumes a significant part in the pressure calculation. It is likewise obvious that the ascent in the quantity of evaporating minutes prompts misfortune in data.

## Acknowledgment

The authors are grateful to The Management of Sathyabama Institute of Science Technology, Chennai, TamilNadu, India.

## References

- [1] Pandian R, Vigneswaran T & Lalitha Kumari S, Characterization of CT cancer lung image using image compression algorithms and feature Extraction, *Journal of Scientific and Industrial Research*, 75 (2016), pp 747-751.
- [2] Syed Mortadza SA, Sim JA, Stacey M, Jiang LH. Signalling mechanisms mediating Zn(2+)-induced TRPM2 channel activation and cell death in microglial cells, "Scientific Repots", Vol. 7, 2017
- [3] R Stephen, K Hongisto, A Solomon, Physical Activity and Alzheimer's Disease: A Systematic Review, *The Journals of Gerontology: Series A*, Vol. 72(6), pp. 733–7, 2017.
- [4] Tijn M. Schouten Anne Hafkemeijer Elise G. P Combining anatomical MRI measures improves Alzheimer's disease classification, *National Library of medicine*, Vol .35(5), 2016, pp. 1920-1929.
- [5] Tijn M. Schouten Anne Hafkemeijer Elise G. P .Combining anatomical MRI measures improves Alzheimer's disease classification, *Neuro Image Clinic*. Vol .35(5), 2016, pp. 1920-1929.
- [6] Sheela K G & Deepa S N , Selection of number of hidden neurons in renewable energy system, *Journal of Scientific and Industrial Research*, 73(2014), 686- 688
- [8] Pandian R, Evaluation of image compression algorithms, *IEEE Und Tech (UT) NIOT*, (2015) 1-3
- [9] Pandian R & Vigneswaran T, Adaptive wavelet packet basis selection for zerotree image coding, *International Journal of Signal and Imaging Systems Engineering*, 9 (2016) 388-392.
- [10] Pandian R .Development of Algorithms for Medical Image Compression: Compression Algorithms, Examining Fractal Image Processing and Analysis. 2020.
- [11] V. D. AK, S. Sharmila, Abhishek Kumar, A. K. Bashir, Mamoon Rashid, Sachin Kumar Gupta & Waleed S. Alnumay . novel solution for finding postpartum haemorrhage using fuzzy neural techniques. *Neural Computing and Applications* (2021) (<https://doi.org/10.1007/s00521-020-05683-z>)
- [12] R. Subha Shini et.al., " Recurrent Neural Network based Text Summarization Techniques by Word Sequence Generation", *IEEE International Conference on Inventive Computation Technologies (ICICT)*, 2021, DOI: 10.1109/ICICT50816.2021.9358764

# Performance Analysis of K-Nearest Neighbor Classification Algorithms for Bank Loan Sectors

Hemachandran K<sup>a,1</sup>, Preetha Mary George<sup>b</sup>, Raul V. Rodriguez<sup>c</sup>, Raviraj M. Kulkarni<sup>d</sup> and Sourav Roy<sup>e</sup>

<sup>a,1</sup> Professor, Woxsen School of Business, Woxsen University, Hyderabad, India

<sup>b</sup> Professor, Dept of Physics, Dr. MGR Educational & Research Institute, India

<sup>c</sup> Dean, Woxsen School of Business, Woxsen University, Hyderabad, India

<sup>d</sup> Professor, Dept of ECE, KLS Gogte Institute of Technology, Karnataka, India

<sup>e</sup> Postdoctoral Research Fellow, Xi'an Jiaotong University, China

**Abstract.** An attempt has been made to develop an algorithm for banks to check the credibility of borrowers to avoid nonperformance assets. People move towards different banks for loan purpose to fulfil their financial needs. Approaching bank for loan is increasing day by day mainly for child marriage, education, agriculture, business, home loan etc. Some people take the loan and they won't pay back in time or some will move out of the country without any intimation, so that bank will go in loss. Even now in covid-19 pandemic many industries were closed but they need to give salary to the employees, need to pay rent and electricity bills too for that they will approach bank for loan. For all these cases bank first need to analyse their Credit Information Bureau India Limited score and check whether they had done loan repayments in appropriate time or not. In the present work the effectiveness of K nearest neighbor algorithm were analysed. This research were carried out using python. The accuracy of this classifier is analysed using following metrics such as Jaccard index, F1-score and LogLoss. This helps to find the potential of the customer which is much higher than the data mining classification algorithm and thus it helps in sanctioning loans.

**Keywords.** F1-score, Jaccard Index, K-Nearest Neighbor Algorithm, Log loss

## 1. Introduction

For the past two decades, there was a rapid increase in demand of sanctioning loans. In the present times, decision to approve loan depended on human decision to gauge the default risk. The increase demand of credit, directed to a leap in the use of official and objective methods of credit-scoring. Credit scoring provides to decide whether to credit bank loan to the applicant or not [1,2]. The intention of credit-scoring is to aid credit suppliers to manage and quantify the monetary risk. By analyzing through the

---

<sup>1</sup> Hemachandran K, Professor, Woxsen School of Business, Woxsen University, Hyderabad, India.  
E-mail:hemachandran.k@woxsen.edu.in

method of credit scoring the applicants of loan can take better lending decisions quickly. It provides a system for the creditors to assign loan to the applicants who are either a "good canditure" or a "bad canditure".

The implementation of K-Nearest Neighbor, is a criterion in recognizing patterns and in non-parametric statistics to the problem of credit scoring [4-6]. The K-NN strategy helps in making a decision about positive or negative danger prospect of the candidate. Also, once more, it sorts great and terrible extent among the most closest comparative k focuses in the preparation tests. An acceptable distance can access the point metric similarity [3].

## 2. Build Data Model

To test this algorithm, the historical data was retrieved from the website of UCI. The KNN algorithm to find on client loans has a definite effect, to help and guide the bank to take a sure decision to reduce the financial risk [7-9]. In Fig.1 it shows 346 records with 10 attributes and to represents the client active-index score which is worthy or ruthless we used 1 or 0. If it gives yes, it tells the customer is healthier and can consider for the sanction of the client's loan, and on the other hand, if it gives no, then that customer is not eligible [16-19].

```
Out[3]:
```

	Unnamed: 0	Unnamed: 0.1	loan_status	Principal	terms	effective_date	due_date	age	education	Gender
0	0	0	PAIDOFF	1000	30	9/8/2016	10/7/2016	45	High School or Below	male
1	2	2	PAIDOFF	1000	30	9/8/2016	10/7/2016	33	Bachelor	female
2	3	3	PAIDOFF	1000	15	9/8/2016	9/22/2016	27	college	male
3	4	4	PAIDOFF	1000	30	9/9/2016	10/8/2016	28	college	female
4	6	6	PAIDOFF	1000	30	9/9/2016	10/8/2016	29	college	male

Figure 1. Dataset

After analyzing the data, how many paid off the previous loan and whoever who made default were also analyzed. Two attributes gender and age have been selected based on that data visualization and pre-processing have been carried out and then convert the categories into numerical values and finally data has been normalized. If the data is not huge, we can do the data cleaning or delete attributes which are not necessary[20-26].

## 3. K-NN Algorithms

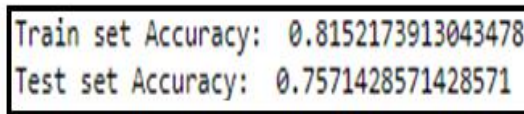
In this method, a set of training sets are taken. Euclidean distance metric estimates the closeness between each preparation model and another model. In this example, highlights of k-NN calculation [10], won't be weighted and they are dealt with identically. The procedure finds the nearest k-value to the next example. The new



example allots the class wherein most of the k neighbor models have a place. Neighbors will be weighed by the reverse of their distance during casting a ballot [11, 13]. The number of neighbors is a deciding element. A reasonable k is to be exactly decided to smoothen the noise. The Selection of suitable nearest-distant points has a significant influence in K-NN strategy. The Euclidean distance is given by

$$D(X,Y) = \{(X-Y)^T(X-Y)\}^{1/2} \quad (1)$$

Based on the train set and test set. The data has been trained and it has been tested using test set. So that the accuracy evaluation has been made and shown in figure 2.



**Figure 2.** Accuracy Evaluation

#### 4. Performance Metrics

Assessment metrics clarify the performance of a model. On the off chance that we have a recorded dataset of client agitates, in the wake of preparing the model we need to ascertain the exactness utilizing the test set. We finish the assessment set to the model to discover anticipated labels [14]. There are three distinctive model evaluation metrics they are Jaccard, F1 score and logloss.

##### 4.1. Jaccard Similarity Score

Jaccard Index additionally called a Jaccard comparability coefficient. For instance, if  $y$  shows the genuine names of the agitate dataset and  $\hat{y}$  shows the anticipated qualities by our classifier [12, 22]. Precision = True '+ve' / (True '+ve' + False '+ve'). Furthermore, Recall is the genuine positive rate. It is characterized as: Recall = True '+ve' / (True '+ve' + False '-ve'). In this way, we can compute the exactness and review of each class

##### 4.2. F1 Score

We can compute the F1 scores for each label, in view of the precision and recall of that label. The F1 score is determined dependent on the precision and recall of each class. The F1-score arrives at its ideal incentive at the very least at 0. It is a generally excellent approach to show that grouping has a decent review and accuracy esteems.

##### 4.3. Log Loss

We can utilize the Log loss in situations where the result of the classifier is a class likelihood and not a class name like in instances of logistic regression models. Log loss

quantifies the exhibition of a model where the anticipated result is a likelihood esteem somewhere in the range of 0 and 1.

Based on the K- Nearest Neighbor accuracy evaluation the three parameter metrics has been evaluated. Whereas log loss value for this model is not applicable.

```
In [45]: # K Nearest Neighbor (KNN)
test_yhat=neigh.predict(test_X)

# jaccard
KNN_Jaccard = jaccard_similarity_score(test_y, test_yhat)
print("KNN - jaccard accuracy = ", KNN_Jaccard)

# f1_score
KNN_f1_score = f1_score(test_y, test_yhat, average='weighted')
print("KNN - f1 score accuracy = ", KNN_f1_score)

KNN - jaccard accuracy = 0.7037037037037037
KNN - f1 score accuracy = 0.6860670194003526
```

**Figure 3.** Performance metrics accuracy

## 5. Result & Conclusion

In this paper, the performance of K Nearest Neighbor classification algorithms were analyses based on three performance metrics Jaccard, F1 score and logloss. These proposed algorithms are used to predict the loan repayment capability behavior of a customer in a cost effective way. The bank officers need to determine whether to approve loan for the applicant or not. This proposed methodology will protect the bank from further misuse, fraud applications etc by identifying the customers whose repayment capability status is risky especially in the banking sector. This research gives that the classification accuracy of KNN is 70%.

**Table 1.** Accuracy Result

Algorithm	Jaccard	F1 Score	Log Loss
K-Nearest Neighbor	0.703704	0.686067	N/A

## References

- [1] Arun, K.,Ishan, G., Sanmeet, K., Loan approval prediction based on machine learning approach. IOSR Journal of Computer Engineering, NCRTCSIT. 2016, pp. 18-21.
- [2] Aafer Y., Du W., Yin H. DroidAPIMiner. Mining API-Level Features for Robust Malware Detection in Android. Security and Privacy in Communication Networks.2013.pp 86-103.
- [3] Hand, D. J., &Vinciotti, V.,Choosing k for two-class nearest neighbor classifiers with unbalanced classes. PatternRecognition Letters.2003. 24, (9-10), pp.1555-1562.
- [4] HanumanthaRao, K., Srinivas, G., Damodhar, A., &Vikar Krishna, M., Implementation of Anomaly Detection Technique Using Machine Learning Algorithms. International Journal of Computer Science and Telecommunications. 2011. 2(3), pp.25-30.
- [5] Haodong Zhu., &Zhong Yong., Based on improved ID3 information gain feature selection method.Computer engineering.2010. 36(8).
- [6] He Y., Han J., Zeng S., Classification Algorithm based on Improved ID3 in Bank Loan Application. Information Engineering and Applications.2012. Pp.1124-1130.

- [7] Houxing You., A Knowledge Management Approach for Real-time Business Intelligence. 2nd International Workshop on Intelligent Systems and Applications, DOI:10.1109/IWISA.2010.5473385. 2010.
- [8] Huang, L., Zhou, CG., Zhou, Yu-qin., & Wang, Zhe., Research on DataMining Algorithms for Automotive Customers' Behavior Prediction Problem. In:2008 Seventh International Conference on Machine Learning and Applications.2008. DOI: 10.1109/ICMLA.2008.23.
- [9] J.M. Chambers., Computational methods for data analysis. Applied Statistics, Wiley.1977. 1(2), pp.1–10.
- [10] Li Xia, ID3 classification algorithm application in bank customer's erosion. Journal Computer technology and development,2009.19(3).
- [11] M. J. Islam., Q. M. J. Wu., M. Ahmadi., & M. A. Sid-Ahmed, Investigating the Performance of Naive-Bayes Classifiers and K- Nearest Neighbor Classifiers. In: International Conference on Convergence Information Technology (ICCIT 2007).2007. pp. 1541-1546.
- [12] Marinakis, Y., Marinaki, M., Doumpos, M. et al., Optimization of nearest neighbor classifiers via metaheuristic algorithms for credit risk assessment. Journal of Global Optimization.2008. 42, pp.279–293.
- [13] Ram, B., & Rama Satish, A., Improved of K-Nearest Neighbor Techniques in Credit Scoring. International Journal For Development of Computer Science & Techno logy.2013. 1(2).
- [14] Sahay, B,S., &Ranjan, J., Real time business intelligence in supply chain analytics. Information Management & Computer Security.2008. 16(1), pp. 28-48.
- [15] Ambeth Kumar.V.D, S. Sharmila, Abhishek Kumar, A. K. Bashir, Mamoon Rashid, Sachin Kumar Gupta &Waleed S. Alnumay .A novel solution for finding postpartum haemorrhage using fuzzy neural techniques. Neural Computing and Applications (2021) (<https://doi.org/10.1007/s00521-020-05683-z>)
- [16] AnkitKumar,VijayakumarVaradarajan,AbhishekKumar, PankajDadheech, SurendraSinghChoudhary, V.D. AmbethKumar, B.K.Panigrahi, KalyanaC.Veluvolug .Black hole attack detection in vehicular ad-hoc network using secure AODV routing algorithm .Microprocessors and Microsystems, In Press,(<https://doi.org/10.1016/j.micpro.2020.103352>)
- [17] Ambeth Kumar.V.D . A Cognitive Model for Adopting ITIL Framework to Improve IT Services in Indian IT Industries.Journal of Intelligent Fuzzy Systems. (DOI: 10.3233/JIFS-189131 )(Accepted - Inpress)
- [18] Ambeth Kumar.V.D .Efficient Data Transfer in Edge Envisioned Environment using Artificial Intelligence based Edge Node Algorithm. Transactions on Emerging Telecommunications Technologies (Accepted - Inpress)(DOI: 10.1002/ett.4110)
- [19] AmbethKumar.V.D , Malathi.S ,AbhishekKumar, Prakash M and Kalyana C. Veluvolu .Active Volume Control in Smart Phones Based on User Activity and Ambient Noise .Sensors 2020, 20(15), 4117; <https://doi.org/10.3390/s20154117>
- [20] Ambeth Kumar S. Malathi R. Venkatesan K Ramalakshmi, Weiping Ding, Abhishek Kumar .Exploration of an innovative geometric parameter based on performance enhancement for foot print recognition. Journal of Intelligent and Fuzzy System , vol. 38, no. 2, pp. 2181-2196, 2020.
- [21] V.D.Ambeth Kumar, Dr.S.Malathi, V.D.Ashok Kumar (2015).Performance Improvement Using an Automation System for Segmentation of Multiple Parametric Features Based on Human Footprint. for the Journal of Electrical Engineering & Technology (JEET) , vol. 10, no. 4, pp.1815-1821 , 2015. [<http://dx.doi.org/10.5370/JEET.2015.10.4.1815>]
- [22] V.D.Ambeth Kumar and M.Ramakrishan (2013).Temple and Maternity Ward Security using FPRS. in the month of May for the Journal of Electrical Engineering & Technology (JEET) ,Vol. 8, No. 3, PP: 633-637. [<http://dx.doi.org/10.5370/JEET.2013.8.3.633>]
- [23] V.D.Ambeth Kumar and M.Ramakrishan (2013) .A Comparative Study of Fuzzy Evolutionary Techniques for Footprint Recognition and Performance Improvement using Wavelet based Fuzzy Neural Network. for the International Journal of Computer Applications in Technology (IJCAT-Inderscience), Vol.48, No.2,pp.95 – 105, [DOI: <http://dx.doi.org/10.1504/IJCAT.2013.056016>]
- [24] Navadeepika.K.M.R, Dr.V.D.Ambeth Kumar.Online Conversion of Tamil Language into Tactile for Visual Impaired People.International Journal of Advanced Science and Technology Vol. 29, No. 5, pp. 3401 - 3407, (2020).
- [25] Rajendiran.M.,Subhashini.P. Energy efficient cluster based leader selection protocol for wireless ad hoc network. International Journal of Computer Science and Engineering Communications (IJCEC), 3(3), 2015.
- [26] Vimala.S, Thilagavathi.S, Valarmathi.K, Priya.R, Sathya.S .Massive Data Processing Using Map Reduce Aggregation to make Digitized India. Advances in Engineering Research, vol. 142, Pp.88-92, 2019

# An Effective Comparative Analysis of Data Preprocessing Techniques in Network Intrusion Detection System Using Deep Neural Networks

Aravind Prakash M<sup>a,1</sup>, Indra Gandhi K<sup>b</sup>, Sriram R<sup>b</sup> and Amaysingh<sup>b</sup>

<sup>a1,b</sup>*Dept of Information Science and Technology, College of Engineering, Chennai, India*

**Abstract.** Recently machine learning algorithms are utilized for identifying network threats. Threats otherwise called as intrusions, will harm the network in a stern manner, thus it must be dealt cautiously. In the proposed research work, a deep learning model has been applied to recognize and categorize unanticipated and unpredictable cyber-attacks. The UNSW NB-15 dataset has a vital number of features which will be learned by the hidden layers present in the suggested model and classified by the output layer. The suitable quantity of layers, neurons in each layer and the optimizer utilized in the proposed work are obtained through a sequence of trial and error experiments. The concluding model acquired can be utilized for estimating future malicious attacks. There are several data preprocessing techniques available at our disposal. We used two types of techniques in our experiment: 1) Log transformation, MinMaxScaling and factorize technique; and 2) Z-score encoding and dummy encoding technique. In general, the selection of data preprocessing techniques has a direct impact on the output performed by any machine learning process and our research, attempts to prove this concept.

**Keywords.** Intrusion detection System (IDS), Attacks, Deep Neural Networks (DNN), Host-based intrusion detection system (HBID), Machine Learning.

## 1. Introduction

Deep Neural Networks (DNN), comes under Machine Learning that enables machines to study samples and predict using the learnt features. The process of feature engineering is not needed in DNN as the features are implicitly learned by the hidden layers which leads to efficiency. An attack is defined as the stealing of information or causing damage to the user's system without the consent of the user. Currently, users are freely sharing sensitive data over the networks without any security awareness and hence it is very essential to protect such data. In this paper, we made a systematic

---

<sup>1</sup>Aravind Prakash M, Dept of Information Science and Technology College of Engineering, Chennai, India.  
E-mail: aravind.2k.135@gmail.com

to cyber-attacks. There are varieties of the attacks in any dataset which includes Fuzzers, Exploits, Generic etc., that can not only damage servers but also make use of the sensitive information of the users [1]. Thus there is a need of an efficient and useful Intrusion Detection System. For creating that, a novel preprocessing technique must be used so that data are properly learned by the system. This way, the prediction accuracy increases. In this paper, Section 2 reviews related recent literature and Section 3 briefly describes the problem description and the proposed method with a simple architecture diagram; Section 4 gives the implementation details of the suggested research work have been narrated; Section 5 briefs the result analysis and its related discussions; and finally Section 6 concludes the research and recommends the direction for future work.

## 2. Literature Review

Intrusion detection system is very essential to ensure information security [2] and the major challenge is to correctly identify different attacks in the network. The process of identifying different types of attacks and accurately classifying the malicious network traffic are posing a great challenge [2]. Convolutional Neural Network (CNN) and Recurrent Neural Network (RNN), are two main types of DNN architectures that are widely explored to enhance the performance of intrusion detection system [2]. Vinayakumar et al. [3, 1] recommended a combination of NIDS and HIDS (Host based Intrusion Detection System) [1]. Binary and multi-class classification are performed on several Intrusion datasets including the UNSW NB-15. Jing et al. [4] have used the same UNSW NB15 [1] dataset, but the machine learning algorithm applied was a Support Vector Machine]. Zhang et al. [5] proposed a NIDS by combining the Improved Principal Component Analysis (IPCA) and Gaussian Naïve Bayes (GNB) and achieved a desirable good accuracy. Zegeye et al. [6] recommended the ideas of intrusion detection system with Hidden Markov Model. The curse of dimensionality has been fixed by this approach i.e., the errors that happen while applying HMM (Hidden Markov Model) to IDS. Asheret et al. [7] put forth a statement that knowledge plays a very essential role in classifying events. The study investigated how knowledge in network operations and information security influenced the detection of intrusions in a simple network [8]. Zhang et al. [9] proposed an intrusion detection system with an algorithm called Synthetic Minority Oversampling Technique combined with Edited Nearest Neighbors (SMOTE-ENN) for balancing network. Zhang et al. [10] proposed an auto encoder-based method for the NSL-KDD dataset which compresses the less important features and extract key features without decoder. Samrin and Vasumathi [11] made investigations on the KDDCup 99 dataset about different techniques and intrusion classifications on the dataset. Meftah et al. [12] proposed a two-stage anomaly-based network intrusion detection process using the UNSW NB-15 dataset and achieved accuracy up to 74%.

## 3. Proposed Work

The overall system architecture is illustrated in Fig.1. In Data preprocessing of UNSW-NB15 dataset, the total number of instances used in the experiment is 2,57,673 out of

which in the first method of data preprocessing where the numerical features are preprocessed by log transformation and then scaled to similar scale by MinMaxScaler. In the second method of data preprocessing, z-score encoding, and dummy encoding is performed for numerical and categorical features respectively. In both the methods, the columns 'id' and 'attack\_cat' are dropped; the column 'label' contains 0 for normal and 1 for attack which will be used as the dependent variable for classification. For multi-class classification, the 'attack\_cat' column can be used by dummy encoding. In Hierarchical Feature Representation module, the features are analyzed and categorized. The variables or features that are categorical in UNSW NB-15 dataset are service, state and proto. All the other features are numeric variables. In Experimenting the dataset with different DNN layers module, the deep learning model must possess definite number of layers, definite number of neurons in each layer, and the appropriate activation functions for the best accuracy and these are found out through a number of experiments. The activation functions used include ReLu, Sigmoid, Softmax [1]. In Training the finalized DNN model module, test-train split is done and the model is trained using the training data. In the first method, it is found that ReLu in the input layer and sigmoid in hidden and output layer performed well. In the second method, the model in which the input layer and hidden layer contains ReLu and the output layer contains softmax performed well. The details about the number of layers and neurons are given in Table 1, 2 and 3. In Loss Function Optimization module, for the first method, binary cross-entropy loss function is used since the label contains binary values. In the second method, categorical cross-entropy is used since the label is preprocessed using dummy encoding. In Intrusion Detection module, after test train split and training the model, the test data can be utilized for prediction. Confusion matrix is constructed and evaluation metrics like accuracy, precision, recall etc., are calculated and tabulated.

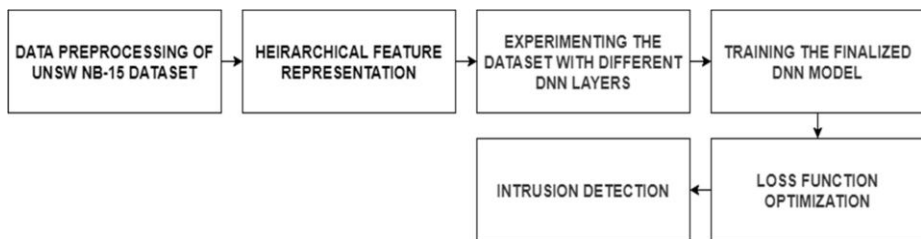


Figure 1. The overall system architecture.

#### 4. Implementation

The experiment is done on an Intel Core i5 8<sup>th</sup> generation processor machine with 8GB RAM @ 2.30GHz. The IDE used are Spyder and JupyterNoteBook which are installed under the Anaconda Python 3.7 environment. As the dataset has huge number of instances and in order to speed up the computation process, Tensorflow has been used as the backend in JupyterNoteBook. Deep learning model has been deployed using the Sequential, Dense functions from keras. Several vital python libraries namely Numpy, Pandas, Scikit-learn are utilized for the effective processing of data.

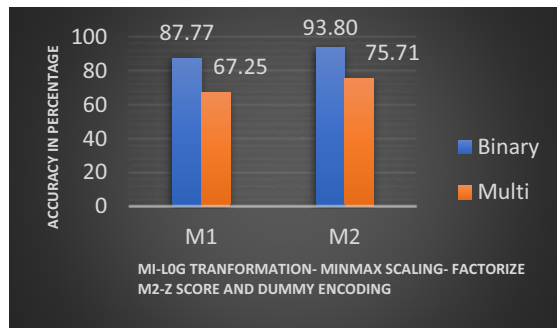
### 5. Results and Discussion

From the results tabulated in Table 1, 2 and 3, the second method in which the data are preprocessed using Z-score encoding and dummy encoding yields better accuracy [1] and have lower false alarms than the earlier suggested method in [3]. The time taken to train the model is also reasonably lower than [3, 1] since there are a smaller number of neurons in each layer than in [3] and thus it is considered as an effective one. True Positive -True Normal (TN); True Negative -True Attack (TA); False Positive -False Attack (FA); False Negative -False Normal (FN). The best accuracy acquired are organized in Tables 1, 2 and 3. All the accuracy related metrics are calculated by the creation of a confusion matrix which is imported from *sklearn.metrics* package[1]. The following are the various basic standard evaluation metrics to rule out the best model in this proposed work and the calculations are shown in Table 1 and 2. Fig 2 depicts the comparative accuracy obtained by the following both the methods.

$$\text{Accuracy} = \frac{TN + TA}{TN + TA + FN + FA} \quad (1) \quad \text{False Positive Rate} = \frac{FA}{FA + TA} \quad (2)$$

$$\text{False Negative Rate} = \frac{FN}{FN + TN} \quad (3) \quad \text{Precision} = \frac{TN}{TN + FA} \quad (4)$$

$$\text{Recall} = \frac{TN}{TN + FN} \quad (5) \quad \text{F1 Score} = \frac{2 * \text{Precision} * \text{Recall}}{\text{Precision} + \text{Recall}} \quad (6)$$



**Figure 2.** Combined analysis of M1 & M2 Preprocessing Techniques. M1- Log Transformation, MinMaxScaling and Factorize M2- Z-score encoding and dummy encoding

**Table 1.** Implementation Results for log transformation, MinMaxScaling and factorize method of data preprocessing (M1) – Binary classification

No. of layers	No of neurons	FPR	FNR	Accuracy	Precision	Recall	F1
3	43, 23, 1	0.1263	0.1984	0.8391	0.8533	0.8015	0.8265
4	43, 23, 11, 1	0.1017	0.2283	0.8325	0.8911	0.7716	0.8270
5	43, 23, 11, 5, 1	0.1214	0.2195	0.8297	0.8642	0.7804	0.8201
6	43, 23, 11, 5, 2, 1	0.2417	0.1036	0.8020	0.6326	0.8963	0.7417
<b>6</b>	<b>256, 128, 64, 32, 16, 1</b>	<b>0.1239</b>	<b>0.1200</b>	<b>0.8777</b>	<b>0.8428</b>	<b>0.8799</b>	<b>0.8609</b>

**Table 2.** Implementation results for z-score and dummy encoding method [13] of data preprocessing – Binary classification

No. of layers	No of neurons	FPR	FNR	Accuracy	Precision	Recall	F1
<b>3</b>	<b>43,23, 2</b>	<b>0.0414</b>	<b>0.0968</b>	<b>0.9380</b>	<b>0.9278</b>	<b>0.9031</b>	<b>0.9152</b>
4	43,23,11,2	0.0453	0.0961	0.9359	0.9206	0.9038	0.9121
5	43,23,11,5, 2	0.0491	0.0881	0.9367	0.9130	0.9118	0.9123
6	43,23,11,5, 2, 2	0.0538	0.0808	0.9366	0.9039	0.9191	0.9114
6	256, 128, 64, 32, 16, 2	0.0502	0.0830	0.9379	0.9107	0.9169	0.9137

**Table 3.** Implementation Results for M1- log transformation, MinMaxScaling and factorize method [13] of data preprocessing and M2 – z-score and dummy encoding method of data preprocessing – Multi-class classification

No. of layers	No of neurons	Accuracy – M1	Accuracy – M2
3	200, 100, 10	<b>0.6725</b>	0.7531
4	200, 100, 100, 10	0.6662	<b>0.7571</b>
5	200, 100, 100, 100, 10	0.6668	0.7528
6	200, 100, 100, 100, 100, 10	0.6532	0.7443



## 6. Conclusion and Future Work

In this proposed research, the attempt is to tune the dataset with various effective data preprocessing techniques to obtain the desired accuracy. It is experimentally proved that preprocessing techniques do have major impacts on any datasets used for any machine learning process. In future, the proposed “Network Intrusion Detection System” paves a way to develop efficient and Intelligent Intrusion Detection systems by the way of incorporating several other prominent machine learning algorithms.

## References

- [1] Aravind Prakash M, Sriram R, Amay Singh. Intelligent Intrusion Detection Systems using Deep Neural Networks (Thesis Report DOT 2020-11). Department of Information Science and Technology, College of Engineering, Guindy, Chennai, Tamil Nadu, India.
- [2] Cui, Jianjing& Long, Jun & Min, Erxue& Liu, Qiang& Li, Qian. (2018). Comparative Study of CNN and RNN for Deep Learning Based Intrusion Detection System: 4th International Conference, ICCCS 2018, Haikou, China, June 8-10, 2018, Revised Selected Papers, Part V. 10.1007/978-3-030-00018-9\_15.
- [3] R, Vinayakumar&Alazab, Mamoun&Kp, Soman&Poornachandran, Prabaharan& Al-Nemrat, A. &Venkatraman, Sitalakshmi. (2019). Deep Learning Approach for Intelligent Intrusion Detection System. IEEE Access. PP. 1-1. 10.1109/ACCESS.2019.2895334.
- [4] Dishan, Jing & Chen, Hai-Bao. (2019). SVM Based Network Intrusion Detection for the UNSW-NB15 Dataset. 1-4. 10.1109/ASICON47005.2019.8983598.
- [5] Zhang, Bing & Liu, Zhiyang&Jia, Yanguo&Ren, Jiadong& Zhao, Xiaolin. (2018). Network Intrusion Detection Method Based on PCA and Bayes Algorithm. Security and Communication Networks. 2018. 1-11. 10.1155/2018/1914980.
- [6] Zegeye, Wondimu& Dean, Richard &Moazzami, Farzad. (2018). Multi-Layer Hidden Markov Model Based Intrusion Detection System. Machine Learning and Knowledge Extraction. 1. 265-286. 10.3390/make1010017.
- [7] Ben-Asher, Noam & Gonzalez, Cleotilde. (2015). Effects of cyber security knowledge on attack detection. Computers in Human Behavior. 48. 51-61. 10.1016/j.chb.2015.01.039.
- [8] Gandhi, K &Janarathanan, S &Sathish, R &Surendar, A. (2020). Dominant Feature Prediction By Improved Structural Similarity Computation. 1-5. 10.1109/ICITIT49094.2020.9071534.
- [9] X. Zhang, J. Ran and J. Mi, An Intrusion Detection System Based on Convolutional Neural Network for Imbalanced Network Traffic, 2019 IEEE 7th International Conference on Computer Science and Network Technology (ICCSNT), Dalian, China, 2019, pp. 456-460, doi: 10.1109/ICCSNT47585.2019.8962490.
- [10] Zhang,C, Ruan,F, L. Yin, X. Chen, L. Zhai and F. Liu. A Deep Learning Approach for Network Intrusion Detection Based on NSL-KDD Dataset. 2019 IEEE 13th International Conference on Anti-counterfeiting, Security, and Identification (ASID), Xiamen, China, 2019, pp. 41-45, doi: 10.1109/ICASID.2019.8925239.
- [11] Samrin.R and Vasumathi.D . Review on anomaly based network intrusion detection system. 2017 International Conference on Electrical, Electronics, Communication, Computer, and Optimization Techniques (ICEECOT), Mysuru, 2017, pp. 141-147, doi: 10.1109/ICEECOT.2017.8284655.
- [12] Meftah S, Rachidi T, Assem N. Network based intrusion detection using the UNSW-NB15 dataset. International Journal of Computing and Digital Systems. 2019;8(5):478-87.
- [13] T. A. Tang, L. Mhamdi, D. McLernon, S. A. R. Zaidi and M. Ghogho. Deep Recurrent Neural Network for Intrusion Detection in SDN-based Networks. 2018 4th IEEE Conference on Network Softwarization and Workshops (NetSoft), Montreal, QC, 2018, pp. 202-206, doi: 10.1109/NETSOFT.2018.8460090.

# Identification of Sickle Cells in Erythrocytes Images Using Shape Descriptors

L.Yamini<sup>a,1</sup>, R.Priyadharsini<sup>b</sup> and A. Beulah<sup>c</sup>

<sup>a,1</sup>UG Student, Dept of CSE, SSN College of Engineering, India

<sup>b</sup>Associate Professor, Dept of CSE, SSN College of Engineering, India

<sup>c</sup>Assistant Professor, Dept of CSE, SSN College of Engineering, India

**Abstract.** Sickle cell anemia is a blood disorder which is widespread across world with an estimate that about 30% of total population will be affected by the end of 2050. Especially in India, the frequency of sickle cell trait can reach up to 35%, thereby increasing attention over the topic for research. It is necessary to detect the disorder as much as it is for finding a cure to it. Therefore, a system that detect the sickle cells from the blood smear images or erythrocytes images is required. The affected cells change their shape from circular to sickle shape, due to the presence of typical hemoglobin called hemoglobin S. Nowadays, the elongated affected cells are identified using image processing techniques. The shape descriptors which are the vital features used to identify any shapes in an image. The contrast and brightness of blood smear images may not be consistent as the acquisition of these images depends on various factors like luminance and chrominance. To detect the sickle cells properly in the blood smear images, the histogram equalization technique is applied to improve the contrast of the image. The image is converted to binary in order to find the boundary of the cells in the image. In the binary image, each normal cell will have holes, Since the normal red blood cell have the shape of a doughnut that has been pressed in the middle slightly. The boundary of all the cells in the image is traced and the holes inside each cells are filled. Each cell is considered as a connected component for which the eccentricity is calculated. The eccentricity is the shape descriptor which is the ratio of the major axis and minor axis of the connected components. If the eccentricity is greater than threshold, the cells are identified as sickle cells.

**Keywords:** Anemia, Connected Component, Eccentricity, Sickle.

## 1. Introduction

Sickle Cell Disease (SCD) is the most common inherited blood disease that results in many complications due to lack of oxygen delivery by sickle cells. SCD can lead to complications such as Anemia, infections, delayed growth, and episodes of pain, called pain crises. To prevent these complications, early diagnosis and treatment of

---

<sup>1</sup>R.Priyadharsini, Associate Professor, Dept of CSE, SSN College of Engineering, Chennai, India.  
E-mail: priyadharsinir@ssn.edu.in

Sickle cell disease is vital. Sickle cells are those red blood cells that go out of shape and become sickle-shaped (like a crescent moon) instead of their normal disc shape. If both parents have sickle cell trait in their genes, their children could get a double dose of the sickle cell gene, which would give them SCD. There are many ways for detecting sickle cells, which include manual detection and Computer Aided Diagnosis (CAD). The manual detection methods are highly prone to errors and require tedious efforts. The commercially available hematology analyzers which work on the principle of SCD is required. In image processing, there are many object detection techniques available, that can be used for many applications. The techniques used for detection are dependent on the nature of the images being applied to. The object detection in an image can be done using edge detection techniques, shape detection using Hough transform, shape descriptors and texture descriptors. This paper provides a more reliable and an accurate method for detecting sickle cells using shape descriptors.

## **2. Data Acquisition**

The images of blood cells are captured using the cell analyser imaging system. The components of the system includes (i) Stabilized light source to illuminate the blood sample, (ii) Motorized stage to move the object into the microscope's field of view, (iii) Microscope optics to magnify the image, (iv) Camera to acquire the images, (v) Digitization process for transforming the video signal into digital format. The blood smear images are examined under oil immersion and are captured in the JPEG format at the maximum resolution.

## **3. Literature Survey**

Sickle cell disease being a common and prominent problem since early 90s has brought attention to various research work in detecting the disease either manually or automatically using image processing techniques to clearly visualise. Even though World Health Organization (WHO) handles the prevention and management of SCD, only minor action is followed. This brought attention to various research works, either manual or automatic detection of SCD. New-borns and occasionally their blood relations will undergo High Performance Liquid Chromatography (HPLC), to separate the blood compounds. Applying Imaging Flow Cytometer in the anticoagulated peripheral venous blood, detects the sickle cells [1]. The authors developed software to classify the normal and sickle cells. After, a series of manual screening of individual blood samples then enter the automatic analysis and classification of different blood cells. The analysis of the blood cells results based on the five different features such as size, roundness, circularity, eccentricity and central gray level distribution. The area, perimeter, diameter, Shape Geometric Factor (SGF), Area proportion (AP), and Deviation value (DV) distinguishes these classes [2]. The DV is the ratio between the SGF and area. If the DV is greater than 0.2, the cell is classified as sickle cell.

Weiner filter along with sobel edge detection technique extracts the boundary of the blood cell [3]. Ellipse adjustment technique analyses the shape of the erythrocytes [4]. Another paper uses Fractal Dimension using box counting technique in recognizing the sickle cells shape [5]. Image enhancement method hue saturation, median filtering and contrast stretching segments the red blood cells in the given sample[6]. Several

machine learning techniques are adopted in detecting sickle cells. Adapted grey world normalization method performs a better colour normalization [7]. The colour normalization reduces the illumination effect in the images. Morphological operators are used in segmenting the different blood cells. Each segmented blood cell is given as input to 3 and 4 layer back propagation neural networks. This system shows a very low error rate. They have applied morphological operations for enhancing the images. K-nearest neighbour classifier classifies the different blood cells based on the features such as aspect ratio, metric value, variance, and radial signature. Circular Hough Transform (CHT) distinguishes the normal and abnormal cells. The neural network and regression tree diagnose the number of sickle cells in the image [8]. Further some study uses Support Vector Machine (SVM) to classify the cells. It uses optimization segmentation, edge smoothing with mean filter to get the features of the blood cells. The classification is done using SVM [9]. Another paper suggests red blood cell classification method for the SCD based on pre-extraction of the cell region and deep Convolution Neural Networks (dCNNs) [10-14].

#### 4. Proposed System

There are many object detection technique available in image processing area which are used for identifying the location, shape and type of objects in an image. The object detection methods are more image specific that is they are dependent on the input being used. The edge detection techniques such as Sobel, Robert, Prewitt, Cannyetc are traditional object detection methods. These methods give the outline of the objects however the output may have false edges. Hough transform is a better option for detection of lines, circles, ellipses and any arbitrary objects in an image. It identifies the features in the Hough space which is very useful even when the edge points are not contiguous, and also can handle noisy data. The transforms may also give misleading results when objects happen to be aligned by chance. These may take too much storage space and time as they detect in Hough space. Texture descriptors are also used for boundary representation. There are statistical, structural and spectral approaches exist for describing the texture of the images. However these methods when applied to blood smear images does not detect the sickle cells accurately. Hence an automatic system that detects the sickle cells from the blood smear image is proposed. The shape descriptors are the essential features that can identify the shape of the sickle cells. In this work, shape descriptors are used to identify the affected cells. Figure 1.shows the process of sickle cell detection.

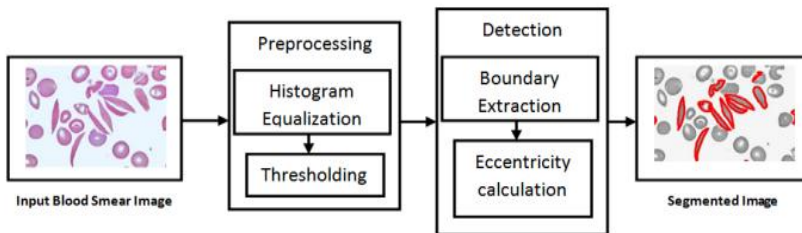


Figure 1. Sickle cell detection process

#### 4.1. Contrast Enhancement

Factors such as illuminance and chrominance affect the contrast and brightness of blood smear images. In order to detect the shape of the sickle cells, preprocessing of the images is required. Preprocessing techniques include the contrast enhancement methods used for improving the intensity values of the images. Histogram equalization is the enhancement technique used in the pre-processing stage for improving the global contrast.

#### 4.2. Shape descriptors

In image processing applications such as object matching, identification and classification, the shape based techniques are widely used. There are area based, boundary based and component based shape descriptors that can be used for object detection and identification. The area based shape descriptors are used when the objects in the image seem to be large. If the objects are very small and not distinguishable from the background, boundary based approaches are generally used. In sickle cell detection, the small sickles are identified by tracing the boundary of the objects.

#### 4.3. Eccentricity

The contrast of the blood smear images are improved using histogram equalization. To find the boundary of the cells in the image, the contrast enhanced image is converted to binary image. As the normal red blood cells have the shape of a doughnut, holes will be present in all the normal cells. In order to identify the sickle cells from the normal ones the holes are filled. The cells in the image are considered as the connected component and the eccentricity is calculated for each cell. The ratio of the major axis and minor axis of the connected components gives the eccentricity. A threshold is set to identify the sickle cells from the normal cells.

### 5. Experimental Result

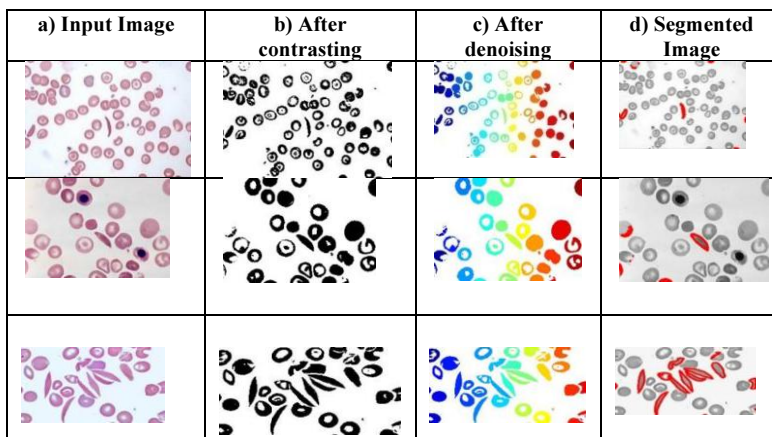


Figure 2. Experimental results of contrasting, denoising and segmentation

## 6. Conclusion

In this paper, identification of sickle cells from blood smear images have been proposed using shape descriptors. The images generally lack in illuminance and chrominance, so all the images are pre-processed before detecting the sickle cells. The histogram equalization is applied to enhance the images and they are converted to binary images. The boundary of the cells are traced by shape descriptors and the eccentricity is calculated. The holes in the normal red blood cells are filled and a threshold is set to detect the sickle cells. The work has been implemented using MATLAB 9.8 version. The experimental results prove that the method has distinctly identified the sickle cells in the blood smear images.

## References

- [1] Van Beers, Eduard J., Leigh Samsel, Laurel Mendelsohn, Rehan Saiyed, Kleber Y. Fertrin, Christine A. Brantner, Mathew P. Daniels, James Nichols, J. Philip McCoy, and Gregory J. Kato. Imaging flow cytometry for automated detection of hypoxia-induced erythrocyte shape change in sickle cell disease. *American journal of hematology* 89, no. 6 (2014): 598-603.
- [2] Taherisadr, Mojtaba, Mona Nasirzonouzi, Behzad Baradaran, Alireza Mehdizade, and I. Shiraz. New approach to red blood cell classification using morphological image processing. *Shiraz E-Medical Journal* 14, no. 1 (2013): 44-53.
- [3] Rakshit, Pranati, and Kriti Bhowmik. Detection of abnormal findings in human RBC in diagnosing G-6-PD deficiency Haemolytic Anaemia using image processing. In *Condition Assessment Techniques in Electrical Systems (CATCON)*, 2013 IEEE 1st International Conference on, pp. 297-302. IEEE, 2013.
- [4] Gonzalez-Hidalgo, Manuel, F. A. Guerrero-Pena, S. Herold-Garcia, Antoni Jaume-i-Capó, and P. D. Marrero-Fernandez. Red blood cell cluster separation from digital images for use in sickle cell disease. *IEEE journal of biomedical and health informatics* 19, no. 4 (2015): 1514-1525.
- [5] Sahu, Menika, Amit Kumar Biswas, and K. Uma. Detection of Sick Cell Anemia in Red Blood Cell: A review. *International Journal of Engineering and Applied Sciences (IJEAS)* 2, no. 3 (2015).
- [6] Mahmood, Nasrul Humaimi, and Muhammad Asraf Mansor. Red blood cells estimation using Hough transform technique. *Signal & Image Processing* 3, no. 2 (2012): 53.
- [7] Hirimutugoda, Y. M., and Gamini Wijayarathna. Image analysis system for detection of red cell disorders using artificial neural networks. *Sri Lanka Journal of Bio-Medical Informatics* 1, no. 1 (2010).
- [8] Sharma V, Rathore A, Vyas G. Detection of sickle cell anaemia and thalassaemia causing abnormalities in thin smear of human blood sample using image processing. In *Inventive Computation Technologies (ICICT)*, International Conference on 2016 Aug 26 (Vol. 3, pp. 1-5). IEEE.
- [9] Akrimi, J.A., Suliman, A., George, L.E. and Ahmad, A.R., 2014. November. Classification red blood cells using support vector machine. In *Information Technology and Multimedia (ICIMU)*, 2014 International Conference on (pp. 265-269). IEEE.
- [10] Xu, M., Papageorgiou, D.P., Abidi, S.Z., Dao, M., Zhao, H. and Karniadakis, G.E., 2017. A deep convolutional neural network for classification of red blood cells in sickle cell anemia. *PLoS computational biology*, 13(10), p.e1005746.
- [11] V. D. AK, S. Sharmila, Abhishek Kumar, A. K. Bashir, Mamoon Rashid, Sachin Kumar Gupta & Waleed S. Alnumay . A novel solution for finding postpartum haemorrhage using fuzzy neural techniques. *Neural Computing and Applications* (2021) (<https://doi.org/10.1007/s00521-020-05683-z>)
- [12] Indhumathi et.al , "Healthcare Management of Major Cardiovascular Disease-A review", 2021 6th International Conference on Inventive Computation Technologies (ICICT), (DOI: 10.1109/ICICT50816.2021.9358519 )
- [13] S.V. Ruphitha et.al, " Management of Major Postpartum Haemorrhage by using Zigbee protocol - A Review ", 2021 6th International Conference on Inventive Computation Technologies (ICICT) (DOI: 10.1109/ICICT50816.2021.9358757 )
- [14] V.D.Ambeth Kumar et.al, "Enhancement in Footprint Image using Diverse Filtering Technique" *Procedia Engineering journal*, Volume 8, No.12, 1072-1080, 2012 . [doi:10.1016/j.proeng.2012.01.965]

# Impact of Personality Traits on Interpersonal Dependency

Dr. S. Jainab Zareena <sup>a,1</sup> Dr. M. Krithika <sup>b</sup>

<sup>a</sup>Assistant Professor, SCAD College of Engineering and Technology Tirunelveli, India

<sup>b</sup>Assistant Professor, Saveetha School of Engineering, Chennai, India

**Abstract:** Every person has a unique personality. A set of characteristics or qualities possessed by an individual is called as the personality traits. Interpersonal dependency refers to the amount of support that an individual gets from the other person and the level of it gets varied among the people. Those who have higher interpersonal dependency are labeled as low self-esteemed person. The present study is initiated to identify the traits possessed by an interpersonal dependent. An adapted questionnaire is used for the study. Totally the questionnaire consists of seventeen questions among which ten questions measured the variable personality traits and the remaining seven questions measured the variable interpersonal dependence. The data was collected from fifty employees working in corporate for the present study. Content and face validities are used to assess the validity. Inferences are drawn through the use of descriptive and inferential statistic.

**Keywords:** Personality traits, interpersonal dependency, self-esteem, negative traits.

## 1. Introduction

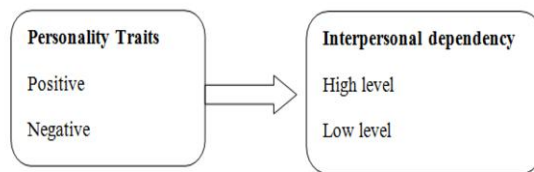
Personality traits are the characteristics or qualities that an individual possess. We all have remarkable personality that makes us unique as compared to the others. Through earlier research studies it is evident that every individual acquire more traits between childhood to adolescence stage and specifically maturity is observed in adulthood stage (Roberts et al. 2006). Personality is structured or built based on five traits namely (i) openness – open minded and challenging person, (ii) conscientiousness – self-disciplined, (iii) extraversion– interpersonal relationship that one has with the another, (iv) agreeableness – tactful and friendly person, and neuroticism–stable and balanced persons. Previous studies highlighted the fact that the level of neuroticism decreases when the level of agreeableness and conscientiousness increases (Kotov et al. 2010). Career is established at the earlier stages of life. During high school, ambitious children will put more effort in their studies. Some roles are forced upon by the society in our late adolescence and young adulthood stage. For example a newly married man may be advised by his elders to be responsible towards his wife or a youth may be advised by his parents to save the money which he earns

---

<sup>1</sup>Dr. S. Jainab Zareena ,Assistant Professor SCAD College of Engineering and Technology Tirunelveli.  
Email:

(Lodi-Smith et al.2007). Being engaged in an intimate relationship is one of the social roles and is performed based on the two criteria. First is one should find a perfect person to develop intimacy and the second is an individual's desire to maintain relationship with one person. Some of the research studies concluded that intimate relationships are captured through identity process (Marcia, 1966). A study conducted by Engel et al. 2002 revealed a strong positive correlation between the personality traits, conscientiousness and interpersonal commitment. Another trait that correlates positively with interpersonal commitment is agreeableness. One's willingness to proceed with a relationship positively influenced interpersonal identity in many studies. Therefore, a strong interpersonal identity has a lower probability of experiencing breakup.

Markus Jokela, (2011) carried out research to investigate the relationship between socioeconomic status and depressive symptoms. The study had two thousand six hundred and seventy eight respondents falling in between the age group of eighteen to forty nine. The socio economic status is assessed by three attributes namely education, occupational status and income level. The study revealed the strong association between low occupational status/ income and depression. It was also found that many individuals suffered from mental health problems due to high depression. Specifically, high level depression was found in individuals with high neuroticism and low extraversion trait. Further, Albrecht et al. (2013) conducted study to assess personality characteristics and academic performance of medical students. Seven hundred and eighty five medical students were the respondents of the study. The result revealed that majority of the students fall under the category of extraversion and agreeableness. Students with low conscientiousness and high sociability were found less likely to sit examination successfully. Similar studies conducted in this area of research proved significant relationship between personality traits and behaviour (Hare and Neumann, 2008; Krueger and Markon,2014; Tyrer, 2015; Lampe and Malhi, 2018). The present study is initiated to identify the traits possessed by an interpersonal dependent. The conceptual frame work of the study is given in fig 1.



**Figure 1.**Framework of the Study

## 2. Methodology & Analysis

An adapted questionnaire is used for the study. Totally the questionnaire consists of seventeen questions among which ten questions measured the variable personality traits and the remaining seven questions measured the variable interpersonal dependence. The data was collected from fifty respondents working in multinational organizations. The convenient sampling technique was used. Content validity is established by



considering the recommendations of professionals working in different organizations. Face validity is established by seeking the opinion of respondents about the questionnaire. Inferences are drawn through the use of descriptive and inferential statistic. The demographic details of the sample are tabulated in table 1.

**Table 1.**Demographic details of the sample

S. No	Variables	Category	Number (out of 50)
1	Gender	Male	30
		Female	20
		IT	35
2.	Industry type	Non IT	15
		3 years and below	6
3	Working experience	4 – 7 years	7
		8 years and above	2
4	Educational Qualification	Post Graduation	25
		Under Graduation	25

Pearson Correlation Analysis is calculated to study the relationship amongst the variables. A strong positive correlation is found to exist between the negative traits and high level interpersonal dependency. Based on the findings it is inferred that the people with interpersonal dependency possess negative personality traits. Note: \*\* $p < .01$ , \* $p < .05$ , ns = not significant Multiple Regression Analysis is calculated to identify which one of the independent variable (positive traits – positive, negative) highly influence the dependent variable (interpersonal dependency). The results are tabulated in table 3. Based on the findings it is inferred that the negative personality trait highly influences the dependent variable interpersonal dependency.

**Table 2.** Pearson Correlation coefficients

Variables	Beta	p value
Positive personality trait	0.453	0.083 (ns)
Negative personality trait	0.653	0.016*

**Table 3.** Multiple Regression - Beta and p value

Variables	Interpersonal dependency High level		Interpersonal dependency Low level	
	r value	p value	r value	p value
<b>Personality Traits</b>				
Positive	0.283	0.621 (ns)	0.111	0.101 (ns)
Negative	0.814	0.000**	0.243	0.081 (ns)

**Note:** \*\*p < .01, \*p < .05, ns = not significant

Dependent Variable: Interpersonal dependency Female respondents obtained higher mean scores (mean = 6.51) than the male respondents (mean = 4.32). Based on the findings it is inferred that the women respondents have higher interpersonal dependency as compared to the male respondents

### 3. Conclusion

Openness has been associated with learning styles that often lead to academic success and higher grades such as analysis of synthesis and methodological study. Conscientiousness and openness are found to predict all four learning styles. Individuals with personality traits such as discipline, commitment, and curiosity are more likely to participate in any one of the learning styles. The most critical thing to remember about interpersonal dependency is self-confidence. One should be self-confident. The study undoubtedly proves the fact that an interpersonal dependent will possess negative traits. However, one can overcome interpersonal dependency. The present study recommends 'can-do attitude' for those who always rely on others.

### References

- [1] Roberts, Brent W., Kate E. Walton, and Wolfgang Viechtbauer. Patterns of mean-level change in personality traits across the life course: a meta-analysis of longitudinal studies. *Psychological bulletin* 132.1 (2006):1.
- [2] Kotov, Gamez, Schmidt, & Watson. Linking big personality traits to anxiety, depressive, and substance use disorders: a meta-analysis. *Psychological bulletin* 136.5 (2010):768
- [3] Marcia, James E. Development and validation of ego-identity status. *Journal of personality and social psychology* 3.5 (1966):551.
- [4] Engel, Gina, Kenneth R. Olson, and Carol Patrick. The personality of love: Fundamental motives and traits related to components of love. *Personality and Individual Differences* 32.5 (2002):839-853.
- [5] Huitt, William G. Personality Differences Between Navajo and Non-Indian College Students: Implications for Instruction. *Equity & Excellence* 24.1 (1988):71-74.

- [6] Albrecht AG, Paulus FM, Dilchert S, Deller J, Ones DS. Construct-and criterion-related validity of the German Core Self-Evaluations Scale. *Journal of Personnel Psychology*. 2013 May;6.
- [7] Lounsbury, Sundstorm, Loveland and Gibson. Broad versus narrow personality traits in predicting academic performance of adolescents. *Learning and individual differences* 14.1 (2002):65-75.
- [8] Hare, R. D., & Neumann, C. S. (2008). Psychopathy as a clinical and empirical construct. *Annu. Rev. Clin. Psychol.*, 4,217-246.
- [9] Krueger, R. F., & Markon, K. E. (2014). The role of the DSM-5 personality trait model in moving toward a quantitative and empirically based approach to classifying personality and psychopathology. *Annual review of clinical psychology*, 10,477-501.
- [10] Tyrer, P., Reed, G. M., & Crawford, M. J. (2015). Classification, assessment, prevalence, and effect of personality disorder. *The Lancet*, 385(9969),717-726.
- [11] Lampe, L., & Malhi, G. S. (2018). Avoidant personality disorder: current insights. *Psychology research and behavior management*.
- [12] Lodi-Smith, Jennifer, and Brent W. Roberts. Social investment and personality: A meta-analysis of the relationship of personality traits to investment in work, family, religion, and volunteerism. *Personality and social psychology review* 11.1 (2007):68-86.
- [13] AnkitKumar, VijayakumarVaradarajan, AbhishekKumar, PankajDadheech, SurendraSinghChoudhary, V.D. AmbethKumar, B.K.Panigrahi, KalyanaC.Veluvolug. Black hole attack detection in vehicular ad-hoc network using secure AODV routing algorithm. *Microprocessors and Microsystems*, In Press, (<https://doi.org/10.1016/j.micpro.2020.103352>)
- [14] VDAK., A Cognitive Model for Adopting ITIL Framework to Improve IT Services in Indian IT Industries. *Journal of Intelligent Fuzzy Systems*. (DOI: 10.3233/JIFS-189131 )(Accepted - Inpress)
- [15] V.D.Ambeth Kumar. Efficient Data Transfer in Edge Envisioned Environment using Artificial Intelligence based Edge Node Algorithm. *Transactions on Emerging Telecommunications Technologies* (Accepted - Inpress)(DOI: 10.1002/ett.4110)
- [16] E.Dhanabal, G.Harish, S.YogaDinesh, V.D.Ambethkumar, M. Rajendiran. Cryptographic enhanced shared data on conserve encipher text update in cloud computing. *Advances in Natural and Applied Sciences*, 11(6), 2017
- [17] A.Santhiya, K.Valarmathi .Android Based Women Tracking System Using GPS and GSM. *International Journal for Research in Applied Science & Engineering Technology*, 4(4),pp181-186, 2017
- [18] Vimala.S, Thilagavathi.S, K.Valarmathi, R.Priya, S.Sathya .Massive Data Processing Using Map Reduce Aggregation to make Digitized India. *Advances in Engineering Research*, vol. 142, Pp.88-92, 2019
- [19] K. Nanagasabapathy; G. Harish; O. I. Allen Sebastian; N. Sowrabh Chandra; V. D. Ambeth Kumar, "Validation system using smartphone luminescence", *IEEE International Conference on Intelligent Computing, Instrumentation and Control Technologies (ICICT)*, Pages: 235 – 239, 6-7 July 2017, Kannur, India
- [20] V. D. Ambeth Kumar et al, " Cloud enabled media streaming using Amazon Web Services", *IEEE International Conference on Smart Technologies and Management for Computing, Communication, Controls, Energy and Materials*, Pages: 195 – 198, 2-4 Aug. 2017, India (DOI: 10.1109/icstm.2017.8089150)
- [21] B. Aravindh; V.D.Ambeth Kumar; G. Harish; V. Siddarth, " A novel graphical authentication system for secure banking systems", *IEEE International Conference on Smart Technologies and Management for Computing, Communication, Controls, Energy and Materials (ICSTM)*, Pages: 177 – 183, 2-4 Aug. 2017, DOI: 10.1109/ICSTM.2017.8089147

# Detection and Classification of Diseases in Cucumber Leaves

RajaKumar.R<sup>a,1</sup>, Pandian.R<sup>b</sup>, and PremJacob.T<sup>c</sup>,

<sup>a</sup>UG Scholar, Dept of ECE, Sathyabama Institute of Science and Technology, Chennai, India

<sup>b</sup>UG Scholar, Dept of ECE, Sathyabama Institute of Science and Technology, Chennai, India

<sup>c</sup>UG Scholar, Dept of ECE, MIT Campus, Anna University, Chennai, India

**Abstract:** Leaf diseases in cucumber must be identified early and accurately as it reduces the yield. Disease detection in plants is the important field of Artificial Intelligent in agriculture. This causes a periodic outbreak of plant diseases which leads to crop death. Automatic plant disease detection may be benefits in monitoring large scale cultivation of crops, and detects the disease symptoms at early stage itself. Here to detect the disease present in the cucumber the tensor flow technique is used and then artificial neural network is used to classify these diseases. The common disease like cucumber mosaic virus, leaf miner, bacterial leaf spot, and leaf blight are examined with disease detection accuracy of 98.66%. This image processing techniques and algorithm are designed using python language to segment the diseases and categories them whether infected or healthy with the help of Pycharm software.

**Keywords:** Tensor Flow Technique, Artificial Neural Networks (ANN).

## 1. Introduction

In recent years, image processing finds a path in both analog and digital domains with technological development and their requirement. Analog image processing comes under the category of using hardware. Using these visual techniques while interpretation image analysts are various fundamentals. Digital image processing deals with digital images or digital signals by using processors. Image processing is done by using various processes. Some of the main processes involved are image filtering, image classification, and image detection. The image is processed using various principles and algorithms. In India, the production of cucumber is more in southern states due to moderate climatic conditions. Cucumber contains higher water content which helps to avoid dehydration during summer seasons. It also finds a place in cosmetics and medicines The production and consumption of cucumber differ from country to country. The major advantages of cucumber are, Cost is cheaper, rich in nutritional value, the investment cost is lower and higher profit.

---

<sup>1</sup>RajaKumar.R, UG Scholar, Dept of ECE, Sathyabama Institute of Science and Technology, Chennai, India.  
E-mail: rkmird@gmail.com

Disease mitigation is the prime factor to be considered in the case of farming practices. So immediate attention should be given to crops which get affected. On observation by naked eyes, it is difficult to recognize the disease in leaf, this might result in the wrong application of pesticides and ultimately it results in crop failure. Hence an automatic system that can detect diseases is mandatory since this system will be useful in monitoring the crops and hence immediate actions can be taken. It is found that image processing techniques will give successful results in disease detection.

Considering this crop because in India up to 65% of total cucumber production are produced in Karnataka which also includes Andhra Pradesh and Tamil Nadu. Leaf diseases in cucumber must be identified early as it reduces the yield. If we have a proper monitoring system for farming it is possible to produce healthy cucumber plant. Main solution is to create a system which can detect the diseases present in cucumber leaf using tensor flow technique which is the first order of business and the second level is to classify them using artificial neural network.

## 2. Related Works

At present many types of research have been carried out in digital image processing particularly in the field of agriculture. We have discussed some of the existing algorithms in this section. In 2019, AbiramiDevaraj et.al [1], described the method of finding and classifying the diseases in cotton leaves. Nearly 80-90% of the leaf diseases that arise in cotton plants are, (i) A fungal disease named *Alternaria* leaf spot and *Cercospora* leaf spot (ii) An Bacterial diseases named Bacterial delight and (iii) Red and brown spots. They used many image processing techniques and ideas to find and classify the diseases in cotton leaves. In 2019, Santhosh Kumar S et.al [2] In order to increase agricultural income and production, devised a system for identifying diseases in plants. It needs a remarkable amount of labor suite a lot of experience with plant diseases and extreme time. Image is processed sing various algorithm. In 2018, M.S. Arya et.al [3] proposed a most significant system for predicting diseases in paddy crops. As we know that consumption of this crop and their need is more in our country. So farmers find difficulties in identifying the diseases. They used some image processing ideas to detect the diseases in the paddy field. In 2017, V. Pooja et.al [4] In recent days most of the plants suffer from many diseases due to changing climatic conditions, unpredictable rain, Pollution, and other environmental impacts. They proposed a paper based on a survey of existing plant diseases and their detection process. Three important steps comprising of pre-processing and analysis of the image, Recognition of plant diseases, and feature extraction is employed here. In 2016 Anand et al [5] proposed a diagnostic mechanism that captures a disease-affected leaf accurately using some algorithms and techniques. They also used ANN Classification techniques for disease identification in plants for its accuracy. In this system features such as HSV and color are extracted in the Segmentation process. In 2015 Y.Sanjana et.al [6] they proposed a system in which mobile phones capture the agriculture field and sent that images to the server for processing. In this method, the classification and detection of leaf diseases are done by using Computer Vision Technology(CVT). They provide a simple approach for the identification of diseases in plants. In 2013 Prof Sanjay B. Dhaygude et.al [7] Mostly diseases fungi, bacteria, and viruses are responsible for diseases in plants. The fungal diseases are caused by reproductive structures in plants and also due to their morphology

[14-15]. These diseases spread to other plants or leaves by means of water, air, movement of contaminated soil or animals. So they proposed a Color transformation structure to detect leaf diseases. Here they used HSV instead of RGB due to its good color descriptor property. In this paper, Section I gives the Introduction part, Section II deals with existing works and their methods, Section III explains the diseases in cucumber leaf, Section IV provides the methodology and the techniques used, Section V gives the output results and their future scope.

### 3. Proposed Work

Step 1: The diseased leaf images are captured using high resolution camera, which the back-ground must be constant black, so it gets isolated from complex back-ground. The main advantage of digital image is that it makes more number of copies without any loss of image quality. Step 2: Then comes to pre-processing, where the conversion of RGB color to grey scale images are produced. The only reason for these conversion is that the RGB image require more space and also consumes larger time period. Step 3: Image segmentation is the method of partitioning a digital image into multiple number of sets of pixels, which should be only done with morphological operation. Step 4: Feature extraction is that the extracted feature is fed into the feature training process, that is done with the help of tensor flow technique. The feature having negative value (-1) as output is represented as diseased feature whereas positive value (+1) is belong to the healthy or normal feature set.

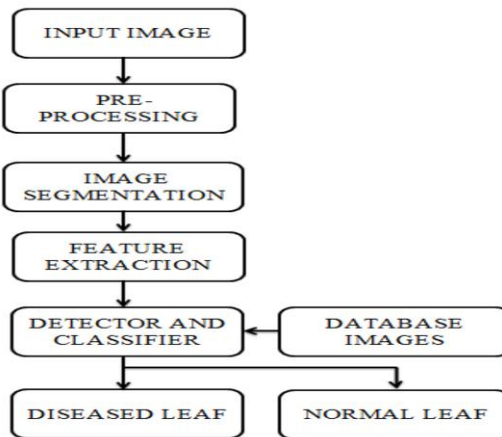


Figure1. Block Diagram

### 4. Methodology

Tensor flow can train and run deep neural network for image recognition-based simulations. It supports production prediction with the same model that is used for the training. Some of the imports used in the model are given below:

1. cv2
2. NumPy
3. OS & tflearn.

#### 4.1 Classification using ANN:

There are four classes for cucumber crop disease classification they are bacterial leaf spot, cucumber mosaic virus, leaf miner and healthy leaf.

#### 4.2 Python programming:

The very first step is to import the function for pooling and then importing the function for convolution. And to load and reshape the data, here we have imported a fully-connected function and regression function. Here to convert the images and then labels to array information is the primary step after the constants are imported. With the help of the tqdm model, we can know about our process by giving the progress bar. Training and testing data are the labeled data sets, where the neural network will fit in the training data, and to test the accuracy of the network the testing data will be used.

### 5. Results and Future Scope

Training a neural network takes more than a few epochs. The main goal of the model is to classify and detect diseased leaves. With the help of global features extracted from the images like shape, color, and texture feature, the model will be able to differentiate the diseased leaf from that of the normal leaf. Relu(Rectified Linear Unit) is a good hidden layer activation choice because it overcomes the weakness and does not suffer from it like sigmoid and tanh. It will control the input value and helps to forward to the next level.

**Table 1.**parameters used in the model

Parameter	Value
Epochs	8
Learning rate	1e-3
Activation in middle layers	Relu
Activation in Final layer	Softmax

Softmax is a normalized exponential function that will output from a given set of N inputs a probability distribution to each input. About 80% of the given dataset used for training the dataset and the remaining 20% of the dataset used for testing. Here the testing dataset will be used to test the accuracy of the network.



**Figure 2.**a)leaf infected b)output for leaf with CMV 3c)Healthy leaf

In this paper, we analyzed the diseases that present in cucumber leaves. By using Artificial Neural Network(ANN) techniques we classified the diseases that are present in cucumber leaf. First, the preprocessing of the leaf is performed, and then disease affected leaf is considered for the tensor flow diagram. The common diseases in cucumber such as leaf miner, leaf spot, and CMV are considered for experimental analysis. The future scope of our work is, with the help of drones or cameras, the large agricultural land is monitored at constant intervals of time and instant information about the farmland is sent to the farmers via mobile apps or SMS. From that farmers can predict the diseases at an early time which helps to avoid larger loss.

## References

- [1] AbiramiDevaraj, KarunyaRathan,SarvepalliJaahnavi, K Indira. Identification of Plant Disease using Image Processing Technique .2019, International Conference on Communication and Signal Processing (ICCSP).
- [2] Santhosh Kumar S, B. K. Raghavendra .Diseases Detection of Various Plant Leaf Using Image Processing Techniques: A Review.2019, 5th International Conference on Advanced Computing & Communication Systems (ICACCS).
- [3] Arya, K Anjali, DivyaUnni .Detection of unhealthy plant leaves using image processing and genetic algorithm with Arduino. 2018, International Conference on Power, Signals, Control and Computation (EPSCICON).
- [4] Pooja, Rahul Das, V Kanchana. Identification of plant leaf diseases using image processing techniques .2017, IEEE Technological Innovations in ICT for Agriculture and Rural Development (TIAR).
- [5] Anand, S Veni, J Aravinth. An application of image processing techniques for detection of diseases on brinjal leaves using k-means clustering method. 2016, International Conference on Recent Trends in Information Technology (ICRTIT).
- [6] Sanjana, AshwathSivasamy, SriJayanth. Plant disease detection using image processing techniques. International Journal of Innovative Research in Science, Engineering and Technology, Vol. 4, Special Issue 6, May 2015.
- [7] Sanjay B. Dhaygude, Mr.NitinP.Kumbhar. Agricultural plant leaf disease detection using image processing. International Journal of Advanced Research in Electrical, Electronics and Instrumentation Engineering Vol. 2, Issue 1, January 2013.
- [8] Pramod S. landge, Sushil A. Patil, Dhanashree S. Khot .Automatic detection and classification of plant disease through image processing .International Journal of Advanced Research in Computer Science and Software Engineering, Volume 3, Issue 7, 2013.
- [9] Heeb Al Bashish, Malik Braik, and SuliemanBani-Ahmad .A Framework for detection and classification of plant leaf and stem diseases. IEEE 2010.
- [10] ZhangJian and Zhang Wei .Support vector machine for recognition of cucumber leaf diseases, in Advanced Computer Control (ICACC). 20102nd International Conference on, 2010, vol. 5. IEEE.
- [11] SatishMadhgoria, MarekSchikora, and Wolfgang Koch .Pixel-based classification method for detecting unhealthy regions in leaf images. 2009.
- [12] Soman, R. Loganathan, and V. Ajay. Machine learning with SVM and other kernel methods, in PHI Learning Pvt. Ltd., 2009.
- [13] SantanuPhadikar and Jaya Sil, Rice disease identification using pattern recognition techniques, in Computer and Information Technology, 2008. ICCIT 2008.11th International Conference on.IEEE, 2008.
- [14] Ambeth Kumar.V.D, S. Sharmila, Abhishek Kumar, A. K. Bashir, Mamoon Rashid, Sachin Kumar Gupta &Waleed S. Alnumay .A novel solution for finding postpartum haemorrhage using fuzzy neural techniques .Neural Computing and Applications (2021) (<https://doi.org/10.1007/s00521-020-05683-z>)
- [15] Ambeth Kumar.V.D, Malathi.S, Ashok Kumar.V.D (2015) .Performance Improvement Using an Automation System for Segmentation of Multiple Parametric Features Based on Human Footprint. for the Journal of Electrical Engineering & Technology (JEET) , vol. 10, no. 4, pp.1815-1821 , 2015. [<http://dx.doi.org/10.5370/JEET.2015.10.4.1815>]



# Lane Detection and Tracking Algorithm Based on Curve Fitting Model

Rajakumar.R<sup>a,1</sup>, Pandian.R<sup>b</sup>, and PremJacob.T<sup>c</sup>,

<sup>a</sup>UG Scholar, Dept of ECE, Sathyabama Institute of Science and Technology, Chennai, India

<sup>b</sup>UG Scholar, Dept of ECE, Sathyabama Institute of Science and Technology, Chennai, India

<sup>c</sup>UG Scholar, Dept of ECE, Anna University, MIT Campus, Chennai, India

**Abstract.** Lane Detection is the fundamental vehicle driving system and self-driving. The proposed concept is to employ the pixel difference in the expected lane and the road backdrop to detach the lane from the road, and then the Curve fitting model is made use of in the segregated lanes to locate the straight line in the image as the lane line. This paper offers a lane detection method based on the Sobel filter and Curve-fitting model for lane line tracking in different conditions. The main objective is to improve the accuracy of the Xi'an city database and the KITTI vision benchmark suite dataset. To achieve this HLS color space was performed which identifies the lane by adding pixel values.

**Keywords.** Sobel filter, Curve fitting model, Lane detection, Lane tracking, sliding window, deep neural network.

## 1. Introduction

Most accidents occur due to invisible road lanes. The accidents can be reduced drastically, by employing improved driving assists. A system that warns the driver, can save considerable number of lives. In driving assistance to achieve safety on roads, the challenging tasks are road lanes' detection or boundaries' detection which is exposed in white and yellow lines on roads. In this work, we developed a Curve fitting model improving the robustness of detecting and tracking the lane for safe transportation. In our method, inspection of lane and its tracking will be done by the Curve fitting model and related component function to improvise the working of the lane detection and tracking.

## 2. Related Works

The literature[1] extracted the Adaptive Region of Interest to minimise computational complexity. Then Kalman filter is used to find road boundaries sensed in the AROI using Progressive Probabilistic Hough Transform (PPHT) in the succeeding frame.

---

<sup>1</sup>Rajakumar.R, UG Scholar, Dept of ECE, Sathyabama Institute of Science and Technology, Chennai, India. e-mail: rkmird@gmail.com

In literature [2] lane marks in road images are extracted which is based on the multi-constraints model and a clustering algorithm based is proposed to detect the lane. The literature [3] used the B-spline fitting lane line from the strength of the RANSAC algorithm for detection offront-view images and improved Hough transform to find rear-view images. The literature [4] improved the accuracy of lane recognition and reduced the difference between pixels. The literature [6] proposed an flexible road detection technique that connects both lane lines and boundaries of obstacle , applicable for detecting lanes. The literature [7] makes use of a color threshold method to identify lane edges with perspective transformations and Hough transform to find out lane segments in the image with measured conditions. These conditions comprise a straight road and a sunny weather. In literature [8] based on the Vision-Based Extrapolation method which performs well in controlled weather conditions and Hough transform used to detect only the straight lane. In this paper just as in [5] edge-based detection with the open street map is used to detect lanes which increases computation time. Hough Transform [9] is employed to identify the straight lane and the Curve fitting model detects the curve lane which increases the computation time [13-14].

### 3. Lane Detection Algorithm

Lane detection in images is a significant operation in image processing and computer vision. Lane detection algorithms detect the lane edges and determine the vehicle position in the lane. A single monocular camera is used for lane detection. This work corresponds to the accurate location of the vehicle in the same lane. This system recognizes the majority of white and yellow markings across the lane effectively during different conditions which include shadows, rain, snow, or other disturbances on the road. The preprocessed image is perspective transformed which converts a 3D image to a 2D image. Then the Sobel filter was performed for noise reduction and to identify the pixel representing the edge. The sliding window method is applied from the bottom of the image by identifying lane pixels. To calculate the vehicle's center offset, the polynomial fit in pixels is used to determine the x position of the left and right lane corresponding to the y at the bottom of the image.

#### 3.1 Sobel Edge Detection

By applying the threshold a particular part of the image, ROI, we have an HLS color image as input. In this step, to locate boundaries of lane ,one edge detection method called the Sobel filter, is used and the boundaries are detected. In Sobel filter, the main objective is to detect the edges that are nearer to the real lane edges. Sobel edge detection basically uses the gradient vector of an intense image. The captured color image is transformed to HLS color space to make the method quicker, computationally less intensive, and less sensitive to scene conditions. To detect the white lane, lightness is set to a value close to 100%. Then the combination of saturation and lightness value was defined to detect the yellow lane. In our proposed method, captured images choose from the directory of the KITTI Benchmark suite, would be processed. The camera is so calibrated that the vanishing point of the road should be kept on the top of the Region of Interest(ROI).

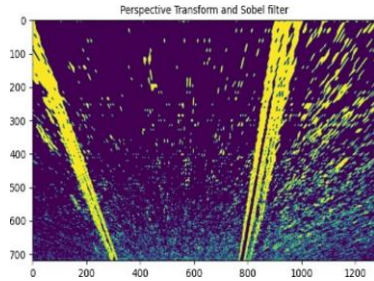


Figure 1.Sobel filter and Perspective transform

### 3.2 Lane Detection and Tracking Flow Chart

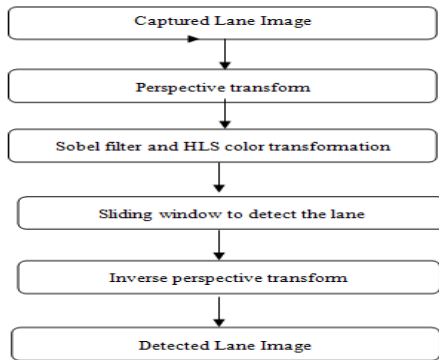


Figure 2. Lane detection and tracking flow chart

## 4. Lane Tracking algorithm

Lane Tracking is mainly employed to increase the computation efficiency of the lane detection algorithm by keeping the earlier information of how the states have an estimate of the future states. This algorithm includes a prediction step as well as a measurement step. In the case of Lane Tracking, the prediction stage involves shifting the detected lanes by a specific amount in the image, based on polynomial fit. In the measurement step, the radius of curvature and vehicle offset were computed.

### 4.1 Sliding Window

To draw multiple sliding windows, the starting point of the windows should be known. To find the initial point, a histogram for the bottom part of the image is calculated. Based on the peak value of the histogram, the initial window is selected and the mean of the non-zero points inside the window is determined. For the first half of the image, the left lane peak is obtained and the other right half gives the peak of the right lane. Thus, left and right starting sliding windows are formed, and then left lane center and right lane center are calculated. This kind of selection works fine for both lanes are in the left

lane on the left side of the image and the right lane on the right side of the image. The sliding window output is in figure 3.

#### 4.2 Lane Design Parameters

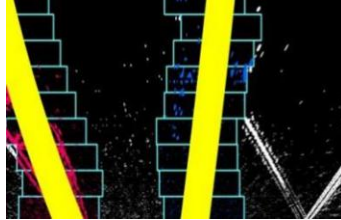


Figure 3. Sliding window output

The equation of the curve model is given as,

$$Ax^2+Bx+C=0 \text{ -----equation (1)}$$

As A, B, C are the constants of the quadratic curve, five of which three constants of the quadratic curve are thus state radius of the curvature is calculated using the y axis point at the bottom of the image.

$$R = (1 + (d^2y/dx^2))^3/2 (dy/dx)^2 dx, dy \text{ are the lane positions.}$$

### 5. Experimental Results

#### 5.1 Lane Detection For Video Frames From Xi'an Citydataset

The present section details the experimental out comes of our method of detection of lane with two sets of various video frames obtained from the Xi'an city dataset.



Figure4.a,b,c,d Output frame of Xi'an city database

#### 5.2 Radius Calculation Of Xi'an City Database

The radius and vehicle offset of a lane in the Xi'an city video database calculated using the equation 2 formula and shown in table 1.

**Table 1.** Radius and Vehicle offset calculation of Xi'an city database

IMAGE	RADIUS (METER)	VEHICLE OFFSET (METER)
Fig.5.a	4.1007	-0.263
Fig.5.b	4.3386	-0.001
Fig.5.c	6.6480	0.0834
Fig.5.d	6.6102	-0.2037

## 6. Conclusion and Future Work

Lane detection was done using the HLS color space and edge detection by using the Sobel filter. Then curve fitting model was used for efficient lane detection and tracking. For two video frames accuracy is calculated as 94.80% and for the KITTI dataset (not described inside this paper) accuracy was calculated as 95.83%. This algorithm computation time was calculated as (150-200 milliseconds/frame) which is suitable for real-time applications. This algorithm can be further developed for self-driving vehicles.

## References

- [1] MehrezMarzougui, Areejalasiry, Yassinkortli and Jamelbaili ,A Lane Tracking Method Based on Progressive Probabilistic Hough Transform, IEEE access vol.8 pp. 84893 - 84905, 13 May 2020.
- [2] HanyuXuan, Hongzhe Liu1, Jiazheng Yuan, And Qing Li, Robust Lane-Mark ExtractionforAutonomousDrivingUnderComplexRealConditions,IEEEAccess,Vol. 6, pp.5749-5766, March 9, 2018.
- [3] HuiXiong;DamengYu;JinxinLiu;HeyeHuang;QingXu;JianqiangWang;Keqiang Li, Fast and robust approaches for lane detection using multi-camera fusion incomplex scenes, IET Intelligent Transport Systems, Volume: 14, Issue: 12, 12 2020), pp. 1582– 1593, 19 November 2020.
- [4] Xingyao Wang, Da Yan, Ke Chen, Yancong Deng, Cheng Long, Kunlin Zhang, Siboyan, Lane Extraction and Quality Evaluation: A Hough Transform Based Approach, 2020 IEEE Conference on Multimedia Information Processing and Retrieval (MIPR), September 03, 2020.
- [5] Guanqi Ding; Xiansheng Qin, Vision-based Edge-lined Assisted Moving Vehicle Detection, 2020 IEEE International Conference on Mechatronics and Automation (ICMA), 13-16 Oct. 2020.
- [6] Jing LiJunzheng Wang; Min Yan, Adaptive road detection method combining lane line and obstacle boundary, IET Image Processing, Volume: 14, Issue: 10, pp. 2216 – 2226, 15 October 2020.
- [7] StevanStević, Marko Dragojević, MomčiloKrunić, NenadČetić, Vision-Based Extrapolation of Road Lane Lines in Controlled Conditions, 2020 Zooming Innovation in Consumer Technologies Conference (ZINC), August 15, 2020.
- [8] Xiaoliang Wang; YeqiQian; Chunxiang Wang; Ming Yang,Map-Enhanced Ego-Lane Detection in the Missing Feature Scenarios, IEEE Access, vol.8, pp. 107958 - 107968, 8 June 2020.
- [9] Huifeng Wang, Yunfei Wang, Xiangmo Zhao, Guiping Wang, He Huang, Jiajia Zhang , Lane Detection of Curving Road for Structural High-way with Straight-curve Model on Vision , IEEE Transactions on Vehicular Technology vol.68 issue:6 pp. 5321-5330,26 April 2019.
- [10] Lim.K.H, et al, Lane detection and Kalman-based linear parabolic lane tracking, International Conference on Intelligent Human-Machine Systems and Cybernetics .2009. pp.351-354.
- [11] Deng.J, and Han .Y. A real-time system of lane detection and tracking based on optimized RANSAC B-spline fitting. Research in Adaptive and Convergent System, 2013, pp. 157-164.
- [12] Gopalan .R, Shneier.M, et al, A learning approach toward detection and tracking of lane markings. IEEE Trans on International Transportation System, vol. 13,no. 3,pp. 1088-1098, Mar. 2012.
- [13] Ambeth Kumar.V.D ,Malathi.S, Ashok Kumar.V.D (2015) .Performance Improvement Using an Automation System for Segmentation of Multiple Parametric Features Based on Human Footprint . for the Journal of Electrical Engineering & Technology (JEET) , vol. 10, no. 4, pp.1815-1821 .2015. [http://dx.doi.org/10.5370/JEET.2015.10.4.1815]

- [14] V.D.Ambeth Kumar et.al,, “An Efficient Security System for Data base Management from Illegal Access, IEEE International Conference on Wireless Communications, Signal Processing and Networking, 2016. DOI: 10.1109/WISPNET.2016.7566252

# Design and Analysis of Hybrid Classification Approaches Across Multi-Relational Decision Tree Learning Algorithm

Tressa Michael<sup>a,1</sup>,

<sup>a,1</sup>Assistant Professor, Dept of ECE, Rajagiri School of Engineering and Technology, Kerala, India

**Abstract.** In today's day of Modern era when the data handling objectives are getting bigger and bigger with respect to volume, learning and inferring knowledge from complex data becomes the utmost problem. Almost all of the real- world information are maintained under a relational fashion holding multiple relations unlike orthodox approaches containing single relational as a whole. Moreover several fields viz. biological informatics, microbiology, chemical computations needed some more dependable and expressive approach which can provide more sophisticated results with faster speed. Hence in context with multi-relational data mining in which data is directly retrieved from different records without dumping into single table, we have described a novel approach of improved Multi-Relational Decision Tree Learning Algorithm based on the implementations. In this paper provided a comparative study of the aforementioned approach in which we have taken certain results from the literature review. Experiments mainly includes results from widely used datasets viz. Mutagenesis database which demonstrates that Multi-Relational Decision Tree Learning Algorithm provides a promising alternative from previous conventional approaches such as Progol, FOIL, and Tilde.

**Keyword.** Data Mining, KDO, Learning Model, MRDTL, Relational Attribute, Relational Table, UML.

## 1. Introduction

The word 'Data Mining' implies to a process of retrieving of important and useful insights through huge large detailed collections of data. Data mining can also be understood as the process of finding new and meaningful patterns through huge amounts of raw and unsettled data. These data amounts could be either reserved or gathered into the respective databases or warehouses another repository sources [1]. Alternatively the action of retrieving unidentified, valid, actionable meaningful data from big data chunks and then utilizing that information to make strategic decisions may also be termed as Data mining. It involves sorting through large amount of data and picking up relevant information and useful patterns in data using different

---

<sup>1</sup>Tressa Michael, Assistant Professor, Dept of ECE, Rajagiri School of Engineering and Technology, Kerala, India, Email:tressa\_m@rajagiritech.edu.in

algorithms to uncover and derive hidden facts. It identifies local obvious patterns within data that go beyond the scope of simple analysis with the help appropriate and sophisticated algorithms [2]. Data mining encompasses various ways taken through different disciplines viz. business intelligence, financial analysis, machine learning, computational and high-performance computing, recognising patterns, visualization of data visualization, retrieval of meaningful information etc. As huge volume of information is increasing exponentially every year, the data acquired is also getting bigger and hence its data mining is turning to be a valuable tool in order to convert the data into meaningful information. This continuous act of research and development has changed mining of data pattern into its refined form.

### *1.1 Functionalities of Data Mining*

The major fundamental functionalities of data mining can be describes as:

(i) Prediction or Predictive Data Mining: It perform inferences on the current data to make prediction and utilizes previously existing variables in a way to decide the values which satisfies the interest. (ii) Description: It characterizes the properties of information through the database which aims on searching patterns which describes the data and then consequent presentation is developed for user interpretation.

The very major and indispensable ingredient for any Data Mining is the database. Any database represents a managed, properly organized and basically huge pile of detailed but raw information regarding some stream or topic linked to outer world. The vital and main work of data mining involves the auditing of the database for pattern consistency which can provide a more sober inference of the topic proposed by the database. In this process we basically take that it includes of a group or pair of individuals [3]. Relying on the topic of the domain, the individual entities may be anonymous, from an account holder to chemical compounds.

## **2. Literature Review**

Ganganwar (2012) represents a brief review of existing techniques for class imbalance that are data resampling approaches and algorithmic approaches. In this data level approaches rebalance the classes artificially by either oversampling or under sampling. In the algorithmic approaches instead of rebalancing, algorithms of classifiers are changed such that making classifiers biased towards the class of interest that is the minority class. Thus by algorithmic approaches more minority instances are classifying but it is very tough to build.

Lopez et al. (2013) carry out a thorough discussion on the data intrinsic problems which lead to poor performance of classifier. Data intrinsic problems includes small disjunctive problems, overlapping between the classes, density of classes in the training dataset, noisy data, borderline instances and data shift between distribution of training and test dataset. It will also introduce several approaches and recommendations for solving this intrinsic problem with the class imbalance problems. And it will also show some experimental examples of the dataset which includes this data intrinsic problems. It would be obvious that successful extraction of data will require a larger database [4]. This article would include treatment for issues surrounding the objective structure of objects. Salters-Wise database provides detailed information about the molecules and tables for the molecules and uses Mendeleev's table of the periodic elements as context



details for the periodic elements (Mendeleev tables) [5]. It is important to learn from and obtain a foothold while Lerner is being rejected (blokila, 1998). Multiple Example Learning Exercises is one where each teaching example is represented by multiple instances (or feature vectors) and they can be applied to all molecules for which molecules have undefined numbers of properties. Many ILP methods [6] have been applied to deal with different issues and will continue to be used in the future.[19-22]

In each of the cases listed above, a range of techniques suggested still rely on their proposed components for the extraction of relevant data. For e.g., ILP Cloudier, TILD and ICL are first order upgrade for proposed data-mining algorithms to enforce a Reinforcement Learning and Reinforcement Learning system by passing rules on affiliation, grouping, and decision-making bodies [7]. The related models for relation domains in the Bayesian networks have eventually been generalized to include the TILDE logical decision-making tree, which includes the decision-making tree introduced in[8], in line with the proposed decision tree algorithm.[16-18] Many adopt a method of updating learning algorithms to conform to the relevant learning, as stated in [9].

### 3. Methodology

#### 3.1 Relational Data Learning

The research in Knowledge Discovery in Databases has been primarily directed to attribute-value learning in which one is described through a fixed set (tuple) given with their values. Database or dataset is seen in the form of table (relation) in which every row corresponds to an instance and column represents an attribute respectively. Base language used lies or based on propositional logic, which can show in the form "Attribute  $\oplus$  Value" where  $\oplus$  can be from a fixed set of predefined operators viz.  $\{<, >, \leq, \geq, =\}$ .

#### 3.2 Proposed Approaches for Relational Data Mining

Several techniques proposed for relational data mining are discussed below: Inductive Logic Programming. The ILP's principle paradigm comprises the usage of Induction and Logic Programming. Prolog is as the principle representative language for implementation and deductive reasoning [10]. The whole process of reducing and deduction basically depends at usage of significant inferring rules. Its presumption includes rules depending statistical support data. Proposed Unified Modelling Language (UML) which can be used as single language for specifying different ILP engines. The main work or aim concentrates to change the whole logic which is depending on formalism which specify the language as proper and sophisticated language which is simple to comprehend and implement consequently, and can be implemented by a different ILP systems, and can also be able to depict the problem's complexity with simple and in clear way. Through this, even non-commissioned users can frame query and can employ different ILP engines, which best fits their requirements. Another problem regarding usage of ILP learning is its confined capabilities for the relational database. Usage of relational engines elevates the ILP system's working strengths. In [11,12], three methods for connecting ILP and relational databases were proposed are explained.

## 4. Experiments and Results

With all the approaches proposed previous to MRDTL, there are numerous results in consideration with multi-relational data mining which apply on several ILP engines in order to infer information from multiple database. We will use a widely used database i.e. Mutagenesis Database [13], which is consistently used in several ILP research and will provide a comparative graphical study with the results obtained from the literature.

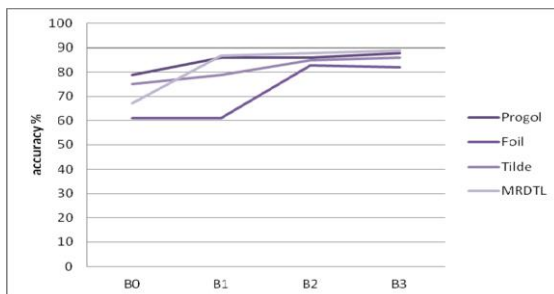
### 4.1 Comparison between MRDTL and previous approaches

The Mutagenesis database holds of 230 entities of molecules which are further sub classified into two groups with 188 molecules which acts as the entities which are regression friendly and 42 molecules acting as regression unfriendly. In friendly section it contains 4893 entities which represents atoms schema and 5243 entities which represents bonds and in other set it contains 1001 and 1066 respectively [14]. The mutagenesis database consists of five levels of background knowledge viz. B0 to B4. A graphical comparison of different previous approaches viz. Progol, FOIL, TILDE with MRDTL [15] using these background knowledge is performed in context with accuracy and execution time. With the results taken from the literature, we had prepared Table 1 comparing the results on the accuracy factor of MRDTL with previous approaches.

**Table 1.** Accuracy Comparisons with Mutagenesis Database

System	Accuracy (%)			
	B0	B1	B3	B4
Progol	79	86	86	88
Foil	62	62	83	82
Tilde	75	78	85	86
MRDTL	67	89	86	89

Due to the dissimilarity in hardware and software decencies employed in the different streams it is almost impossible to implement these algorithms in real world. Despite the fact that certain ILP depending engines viz. Tilde and FOIL are present online through the internet, but all of them works only on the Solaris OS versions only. Hence, we are not able to could reproduce those facts in our working paradigms. So using the values provided in the literature we had provided a graphical comparison of MRDTL with previous approaches. With the results obtained, it is evident from the Fig. 1, that MRDTL approach is much more consistent, accurate and signifies its better approach.



**Figure 1.** Graphical Comparison (accuracy) of MRDTL with previous approaches

We had prepared a Table 1 using the results comparing the running time factor of MRDTL with previous approaches.

**Table 2.** Comparison on Performance Accuracy

Dataset	MRDTL accuracy (%)	Hybrid MRDTL accuracy (%)
<b>Mut dataset</b>	87.5	86
<b>Loc dataset</b>	76.11	72.10
<b>Function dataset</b>	91.44	93.6
<b>Thrombosis dataset</b>	98.1	99.28

These results are graphically mapped, it is evident from the graph that Hybrid Multi-Relational Decision Tree Learning Algorithm more accurate than its predecessor.

## 5. Conclusion

In this paper we have provided a comparative study of the aforementioned approach in which we have taken certain results from the literature. Our experiments mainly includes results from widely used datasets viz. Mutagenesis database which demonstrates that MRDTL algorithm provides a promising alternative from previous conventional approaches such as Progol, FOIL, and Tilde. Our research also points out certain major drawbacks of this approach which causes hindrance in its smooth working. Consequently we introduced a much more sophisticated and deserving approach i.e. improved Multi-Relational Decision Tree Learning Algorithm which overcomes with those drawbacks and other anomalies. Slow performance: improved Multi-Relational Decision Tree Learning Algorithm provides certain methods which reduces its execution time. Experimental results on different datasets provide a clear indication that improved Multi-Relational Decision Tree Learning Algorithm is comprehensively a better approach.

## References

- [1] Kersting, K. and De Raedt, L. Bayesian Logic Programs. Proceedings of the Work-in Progress Track at the 10th International Conference on Inductive Logic Programming (2000).
- [2] Pfeffer, A. A Bayesian Language for Cumulative Learning, Proceedings of AAAI 2000. Workshop on

- Learning Statistical Models from Relational Data, AAAI Press (2000).
- [3] Krogel, M. and Wrobel, S. Transformation-Based Learning Using Multirelational Aggregation. Proceedings of the 11th International Conference on Inductive Logic Programming, vol. 2157(2001).
  - [4] Getoor, L., Multi-relational data mining using probabilistic relational models: research summary. Proceedings of the First Workshop in Multi-relational Data Mining (2001).
  - [5] Knobbe, A. J., Siebes, A., Blockeel, H., and Vander Wallen, D. Multi-relational data mining using UML for ILP. Proceedings of the First Workshop in Multirelational Data Mining, 2001.
  - [6] Hector Ariel Leiva . A Multi-Relational Decision Tree Learning Algorithm .M.S. thesis, Department of Computer Science. Iowa State University (2002).
  - [7] Y. Sun, M.S. Kamel, Y. Wang .Boosting for Learning Multiple Classes with Imbalanced Class Distribution .Proc. Int'l Conf. Data Mining, pp. 592-602. 2006.
  - [8] N. Abe, B. Zadrozny, J. Langford. An Iterative Method for Multi-Class Cost-Sensitive Learning. Proc.ACM SIGKDD Int'l Conf. Knowledge Discovery and Data Mining, pp. 3-11, 2004
  - [9] K. Chen, B.L. Lu, J. Kwok. Efficient Classification of Multi-Label and Imbalanced Data Using Min-Max Modular Classifiers. Proc. World Congress on Computation Intelligence—Int'l Joint Conf. Neural Networks, pp. 1770-1775, 2006.
  - [10] Mr. Ankit Kumar, Dr. Dinesh Goyal, Mr. Pankaj Dadheech, (2018). A Novel Framework for Performance Optimization of Routing Protocol in VANET Network.Journal of Advanced Research in Dynamical & Control Systems, Vol. 10, 02-Special Issue, 2018, pp-2110-2121, ISSN: 1943-023X.
  - [11] Mr. Pankaj Dadheech, Dr. Dinesh Goyal, Dr. Sumit Srivastava, Mr. Ankit Kumar, (2018). A Scalable Data Processing Using Hadoop & MapReduce for Big Data. Journal of Advanced Research in Dynamical & Control Systems, Vol. 10, 02-Special Issue, 2018, pp-2099-2109, ISSN: 1943-023X.
  - [12] Pankaj Dadheech, Dinesh Goyal, Sumit Srivastava & C. M. Choudhary, (2018). An Efficient Approach for Big Data Processing Using Spatial Boolean Queries. Journal of Statistics and Management Systems (JSMS), 21:4, 583-591.
  - [13] A. Kumar and M. Sinha (2014).Overview on vehicular ad hoc network and its security issues. International Conference on Computing for Sustainable Global Development (INDIACom), pp. 792-797. doi: 10.1109/IndiaCom.2014.6828071.
  - [14] Pankaj Dadheech, Ankit Kumar, Chothmal Choudhary, Mahender Kumar Beniwal, Sanwta Ram Dogiwal & Basant Agarwal (2019). An Enhanced 4-Way Technique Using Cookies for Robust Authentication Process in Wireless Network. Journal of Statistics and Management Systems, 22:4, 773-782, DOI: 10.1080/09720510.2019.1609557.
  - [15] Ankit Kumar, Pankaj Dadheech, Vijander Singh, Linesh Raja & Ramesh C. Poonia (2019).An Enhanced Quantum Key Distribution Protocol for Security Authentication. Journal of Discrete Mathematical Sciences and Cryptography. 22:4, 499-507. DOI: 10.1080/09720529.2019.1637154.
  - [16] VDAK, S. Sharmila, Abhishek Kumar, A. K. Bashir, Mamoon Rashid, Sachin Kumar Gupta & Waleed S. Alnumay .A novel solution for finding postpartum haemorrhage using fuzzy neural techniques. Neural Computing and Applications (2021) (<https://doi.org/10.1007/s00521-020-05683-z>)
  - [17] AnkitKumar,VijayakumarVaradarajan,AbhishekKumar, PankajDadheech, Surendra SinghChoudhary, V.D. AmbethKumar, B.K.Panigrahi, Kalyana C.Veluvolug. Black hole attack detection in vehicular ad-hoc network using secure AODV routing algorithm. Microprocessors and Microsystems, In Press,(<https://doi.org/10.1016/j.micpro.2020.103352>)
  - [18] Ambeth Kumar.A Cognitive Model for Adopting ITIL Framework to Improve IT Services in Indian IT Industries. Journal of Intelligent Fuzzy Systems. (DOI: 10.3233/JIFS-189131 )(Accepted - Inpress)
  - [19] V.D.AKumar .Efficient Data Transfer in Edge Envisioned Environment using Artificial Intelligence based Edge Node Algorithm. Transactions on Emerging Telecommunications Technologies (Accepted - Inpress)(DOI: 10.1002/ett.4110)
  - [20] V. D. AK ,S. Malathi,Abhishek Kumar,Prakash M and Kalyana C. Veluvolu .Active Volume Control in Smart Phones Based on User Activity and Ambient Noise .Sensors 2020, 20(15), 4117; <https://doi.org/10.3390/s20154117>
  - [21] AK S. Malathi R. Venkatesan K Ramalakshmi, Weiping Ding, Abhishek Kumar .Exploration of an innovative geometric parameter based on performance enhancement for foot print recognition. Journal of Intelligent and Fuzzy System . vol. 38, no. 2, pp. 2181-2196. 2020. DOI: 10.3233/JIFS-190982
  - [22] B. Aravindh; V.D.Ambeth Kumar; G. Harish; V. Siddarth, “ A novel graphical authentication system for secure banking systems”, IEEE (ICSTM), Pages: 177 – 183, 2-4 Aug. 2017, DOI: 10.1109/ICSTM.2017.8089147

# User Recommendation in OSN

ChristiyanaArulselvi A<sup>a,1</sup>, SendhilkumarS<sup>b</sup> and Mahalakshmi G S<sup>c</sup>

<sup>a</sup>Assistant Professor, Dept of Computer Applications, SRM Institute of Science & Technology, Chennai, India

<sup>b</sup>Associate Professor, Dept of IT, Anna University, Chennai, India

<sup>c</sup>Associate Professor, Dept of CSE, Anna University, Chennai, India

**Abstract.** Web based Social Network (SN) is one of the popular mediums where the information is shared among users. The combined data from different sources available on the open web needs to be evaluated for its quality and trustworthiness. A trustable community can be formed, if the social networking applications, media, forums, etc., can automatically judge the user who requests to join the community. It is necessary to know the trustability of the persons within the community to share the official and personal information. Therefore, a trust model has become an essential part of Online Social Network (OSN) to find the trustworthiness of the requester. Significance of the work detailed here is to model a trustworthy user suggestion in OSN applications.

**Keywords.** User recommendation, collaborative filtering, interaction data, Trust, OSN

## 1. Introduction

The momentous development in the technological innovation incredibly affects medium in which people communicate with each other. The impact is evidenced with the way, web-based media for example broadcast communication framework, texting, WWW and interpersonal interaction sites are working. Social networks allow users to share the events happening on the open forum through posting photos, messages and status updates. It helps the users to share a wide range of data among friends. Despite the fact that OSNs permit to associate with companions, Web 2.0 and OSNs encourage the way for bogus and misdirecting data which needs check mechanism [1]. OSNs today demands people in decision making. Current social networks being an online community requires recommendation from third party for decision making. The recommendation in OSN could be user-items recommendation and user-user recommendation. In user based community users are prone to have the threat enforced by the imposters in order to abuse the users. Anticipating and eradicating such imposters is the requisite for the virtual environments like OSN[2]. In addition to the eradication of the imposters, suggesting trustworthy user will protect and enhance the wellbeing of the community. In user based community users are prone to have the threat enforced by the imposters in order to abuse the users. Anticipating and eradicating such imposters is the requisite for the virtual environments like OSN[2].

---

<sup>1</sup>ChristiyanaArulselvi A, Dept of Computer Applications, SRM Institute of Science & Technology, India; E-mail: christia@srmist.edu.in

## 2. Related Works

A recommendation system can be described as a decision-making method that allows the user to make the choice [3]. The various recommendation systems that had been proposed in the literature [4] to solve the shortcomings in OSN are collaborative filtering, content-based filtering, demographic, knowledge-based [5, 6, 7], utility-based recommendation and hybrid recommendation [8]. Among these recommendation systems, the proposed system adopts collaborative filtering recommendation system. Generally, item recommendation in OSN is achieved from the user's reviews on the item or the user's past online purchase behaviour. User recommendation could be achieved through the user profile [9] which contains users' demographic information like language, locality, interest, etc., and users' interaction information. The profile information is the factors that influence the user's personalized recommendation. Attitude, behavior and experience are the three main sources of trust computation [10]. Interaction behavior of the user reflects the real closeness between or among users. Krishnaprasad Thirunarayan & Pramod Anantharam[11] analyzed friends' conversational information in Facebook to determine trust between friends in social networks. Sibel Adali et al. [12] mentioned trust is an important but complex among the users of OSN and proposed a trust model based on the user behaviour in terms of conversational and propagational data available in OSN for twitter data. Sapna Gambhir & Vinod Kumar [13] proposed a trust computation system in OSN between users based on time duration of various actions (message, comments, shares, likes, tags) that was happened.

## 3. Collaborative Filtering Based Trust Model

OSN in the present state of affairs is a major instrument for social network. In such virtual environment, people are looking for genuine users to make the interactions healthier and interesting. A recommendation system is a form of decision support system that is used to ascertain user's favourites. Users get suggestions from the system based on their interests and those of other users. Recommendation systems is an important tool that analyzes users' actions and make recommendations based on their favorites. The aim of the proposed personalized recommendations is to 1) find trustworthy users who can help OSN users, 2) screen friend requests by detecting imposters (untrustworthy users), and 3) maintain a secure and healthy group.

Though the collaborative filtering technique is mostly used to recommend items based on similarity among users, the proposed system recommend a user (alter) to another user (alter) based on the reputation gained by the prime user on alter based on interaction. The proposed research work uses frequency pattern among various type of user behavior patterns described by Park DHet al. [16]. Trust value (user rating) could be predicted using stochastic model once the latent features are identified [15][18]. The process of trust prediction as proposed by Christiyana et al [2] and user recommendation for the proposed work is explained below:

- 1) Compute the prime user's reputation on another user x based on prime user's interaction using stochastic differential equation.
- 2) Compute trust from the reputation value, which defines the closeness of prime user with user x.

- 3) Recommend user  $x$  to  $(n-x)$  users in prime user's community or to give suggestion to the users who received the friend request from user  $x$ . This process of recommendation is explained herewith.

#### 4. User Recommendation in OSN

In OSN environs, the recommendation framework is utilized to supply prospective users to the focused based on the user actions. Though the individuals are overwhelmed with data detecting an individual who is likely to be included in the companion list isn't an issue any longer but *identifying* and offering the prospective users to the focused may be a crucial assignment in OSN. A guideline process was designed to bridge the fissure among collecting, investigating, cleaning the accessible data and presenting it to the target audience. Hence, the proposed strategy employs reputation-based user believe framework to identify and recommend the prospective user to the requested. Sample trust value obtained using stochastic model and Bayesian classification process by Christiyana et al [2] is given in Table 1.

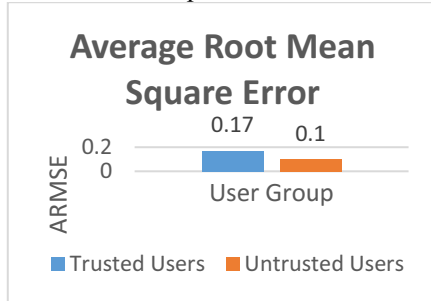
**Table 1.** Trustability of ego user ( $p$ ) on every other users ( $n-p$ ) of ego user community

User id	Like	Comment	Chat	Class
u1	0.05	0.07	0.30	R
u2	0.04	0.12	0.01	R
u3	0.06	0.00	0.32	R
u4	0.05	0.03	0.37	R
u5	0.05	0.13	0.04	R
u6	0.06	0.15	0.01	R

The fields Like, Comment and Chat in Table 1 are the parameters used for the current research work to compute the trustability of the ego user on every other user in the community. These parameters are extracted from individual user's timeline and chat sessions in FaceBook. Values of these parameters are computed using stochastic model proposed by Christiyana et al [2]. The field named 'Class' in Table 1 defined the accepted (A) and refused (R) labels as trusted and untrusted users respectively. The corresponding output were classified using Bayesian classifier with 96.7% accuracy. The precision test of the classifier showed that 96.7 percent of trusted users classified are reliable [2]. The recommendation system thus built using stochastic and Bayesian classification is evaluated for its effectiveness as in section 5.

## 5. Performance of User Recommendation

To assess the performance of the current research work defined for the trustworthy user community, the groups generated by the current research work must be analyzed. The trusted and untrusted user groups formed by the current research work is assessed using the statistical measures called Average Root Mean Square Error (ARMSE). Expected groups' consistency is measured using Average Root Mean Square Error (ARMSE), a statistical metric. The sample set of ego users were provided with the expected trust groups (Trusted and Untrusted users) created by the current system and their feedbacks were measured using the Average Root Mean Square Error (ARMSE) metric. The lower the error value, the higher the expected group's quality. Figure 1 shows the error value produced by ARMSE metric for the predicted trusted and untrusted group



**Figure 1.** User recommendation - Performance evaluation

From the Fig. 1 it is observed that the average of the ARME computed for the trusted and untrusted groups were 0.135, which is approximately 0.14. Therefore, 86% of the friend recommendation proposed by the current method is accurate in terms of ego user's confidence expectations. A recommendation system, which is a form of decision support system, assists the requested (targeted) in predicting the appropriate users in order to make a friend request decision. The proposed recommendation mechanism is based on the user's interaction experience, with frequency of interaction being used to calculate the user's confidence.

## 6. Conclusion

The work reported here provides a collaborative filtering approach for a user (friend) recommendation towards the friend request by considering various factors like frequency and content of interaction. A user recommendation for a friend request is a challenging task because the current user recommendation is based on the link structure between users. The proposed work overcomes the drawbacks of existing system by identifying the potential users with respect to the prime (ego) user and the mutual interest between the requester and the requested. The research reported here is to overcome the problems of friend request in OSN. A trusted user is recommended to alter of the ego user who is receiving friend request from another alter or to raise the friend request towards another trusted similar user.



## Acknowledgements

This Publication is an outcome of the R&D work undertaken in the project under the Visvesvaraya PhD Scheme (Unique Awardee Number: VISPHD-MEITY-2959) of Ministry of Electronics & Information Technology, Government of India, being implemented by Digital India Corporation (formerly Media Lab Asia).

## References

- [1] Sonja Grabner-Kräuter&Sofie Bitter .Trust in online social networks: A multifaceted perspective. Forum for Social Economics, 2015, vol. 44. No. 1, pp.48-68, Routledge.
- [2] ChristiyanaArulselvi A, Sendhilkumar S &Mahalakshmi GS .Provenance based Trust computation for Recommendation in Social Network .In proceeding of International Conference on Informatics and Analytics (ICIA-16), (Pondicherry Engineering College, Pondicherry, India, 25th – 26th August 2016), ACM Article No. 114, DOI: 10.1145/2980258.2982105.
- [3] ChristiyanaArulselvi. A, SendhilKumar S, and Mahalakshmi G S.Hybrid User Recommendation in Online Social Network.In Computational Vision and Bio Inspired Computing, 2018.pp. 134-151. Springer, Cham.
- [4] SreeParvathy V &Ratheesh TK .Friend recommendation system for online social networks: A survey. In proceedings of International conference of Electronics, Communication and Aerospace Technology, Coimbatore, India, 2017, pp. 359–365.
- [5] Burke R Hybrid .Recommender systems: survey and experiments. User Model User-adapted Interact 2002. vol. 12. no. 4. pp. 331–170.
- [6] Pathak D, Matharia S & Murthy C .Nova: Hybrid book recommendation engine.In proceedings of 3rd International Advance Computing IEEE Conference, Ghaziabad, India, 2013, pp. 977–982.
- [7] Adomavicius G &Tuzhilin A 2005.Toward the next generation of recommender system: A survey of the State-of-the-Art and Possible Extensions. IEEE Transactions on Knowledge and Data Engineering, vol. 17, no. 6, pp. 734–49.
- [8] Jannach D, Zanker M, Felfernig A & Friedrich G, Recommender systems: An introduction, Cambridge University Press, 2010.
- [9] Bobadilla J, Ortega F, Hernando A & Gutierrez A .Recommender systems survey. Knowledge-Based Systems, 2013.vol. 46,pp. 109–132.
- [10] WanitaSherchan, Surya Nepal & Cecile Paris. A Survey of Trust in Social Networks. Journal of ACM Computing Surveys, 2013, vol. 45(4), Article no. 47. pp. 1-33.
- [11] KrishnaprasadThirunarayan&PramodAnantharam .Some Trust Issues in Social Networks and Sensor Networks. In proceedings of IEEE International Symposium on Collaborative Technologies and Systems, Chicago, IL, USA, 2010, pp. 573-580.
- [12] SibelAdali, Robert Escriva, Mark K Goldberg, MykolaHayvanovych, Malik Magdon Ismail, Boleslaw K Szymanski, William A Wallace & Gregory T Williams .Measuring Behavioral trust in Social Networks. In proceeding of IEEE International Conference on Intelligence and Security Informatics, Vancouver, BC, Canada. 2010.pp. 150-152.
- [13] SapnaGambhir&Vinod Kumar .Bidirectional Trust Calculation in Online Social Networks. In proceedings of 4th International Conference on Reliability. Infocom Technologies and Optimization, Noida, India. 2015. pp. 1-6.
- [14] Isinkaye FO, Folajimi YO &Ojokoh BA. Recommendation systems: Principles, methods and evaluation. Egyptian Informatics Journal, 2015. vol. 16, no. 3, pp. 261-273.
- [15] Wei-Po Lee &Chau Yuan Ma.Enhancing Collaborative recommendation performance by combining user preference and Trust-Distrust propagation in Social Network. Knowledge-Based Systems, 2016. vol. 106, pp. 125-134.
- [16] Park DH, Kim HK, Choi IY, Kim JK .A literature review and classification of recommender systems research. Expert Systems with Applications, 2012, vol. 39, no. 11, pp. 10059–10072.
- [17] Christiyana Arulselvi A, Dhanalakshmi T &Sendhilkumar S .Reputation based Trust Computation for Social Network.National Conference on Intelligent Computing and Data Analytics, Anna University, Chennai, 24th March 2016, pp. 183-193.
- [18] AnkitKumar,Vijayakumar Varadarajan,C.Veluvolug. Black hole attack detection in vehicular ad-hoc network using secure AODV routing algorithm .Microprocessors and Microsystems, In Press,(<https://doi.org/10.1016/j.micpro.2020.103352>)

# Feasibility of Convolutional Neural Networks (CNN) for Content Based Image Retrieval of Images from Hadoop

Muthiah.M.A<sup>a,1</sup>, Logashanmugam.E<sup>b</sup>, and Nandhitha.N.M<sup>c</sup>

<sup>a</sup>Research scholar, School of Electrical and Electronics, Sathyabama Institute of Science and Technology, Chennai

<sup>b</sup>Professor, School of Electrical and Electronics, Sathyabama Institute of Science and Technology, Chennai

<sup>c</sup>Professor, School of Electrical and Electronics, Sathyabama Institute of Science and Technology, Chennai

**Abstract.** In search engines, though feature-based query is provided, Content Based Image Retrieval (CBIR) still results in less sensitivity and specificity. It is because the conventional approach is based on feature extraction and inherent parameters in conventional feed forward networks. Performance of the system is strongly dependent on the extracted features. Hence it is necessary to develop a CBIR system that retrieves the similar images without explicit feature extraction. Convolutional Neural Networks are the recent neural network architectures which accept images as input and perform both feature extraction and classification. The proposed work aims at using the conventional architectures of VGGNET, RESNET, and DENSENET for flower classification in CBIR. Performance is measured in terms of accuracy of classification.

**Keywords.** CBIR, Deep learning, Accuracy, Big data, Hadoop.

## 1. Introduction

Image classification for CBIR is an important application of digital image processing. Initially the image database is collected and the images are studied. Having understood the metadata, features must be identified for representing the images. Real challenge lies in identifying the correct features for that particular application. Various features namely shape features, statistical features, texture features are cited in the literature. These features or a new set of image specific features must be identified. Having identified the features, the next task is to check the suitability of these features. These features must be similar for the same set of images and must be different between sets i.e less intra class variance and high interclass variance. This criterion is difficult to achieve in case of real time images and hence research continues in this area of feature engineering.

---

<sup>1</sup>Muthiah.A, Research Scholar, School of Electrical and Electronics Sathyabama Institute of Science and Technology, Chennai, India.  
Email:lmuthiah@gmail.com<sup>1</sup>

Once satisfied with the features, these features are then given as inputs to either unsupervised or supervised algorithms for classification. Though the accuracy of classification is dependent on the classification algorithm, its inherent parameters, it is strongly dependent on the extracted features. So the paradigm has shifted to algorithms which perform feature extraction and classification. Such networks are called Deep learning networks as the depth of the network is in the order of 50s and 100s, i.e. the number of layers in these networks is more. Deep learning Networks are available for both signal analysis (Recurrent Neural Network, Long Short Term Memory recurrent network) and image analysis (Convolutional Neural Networks). Convolutional Neural Networks are called so because they use convolution operator to extract the features. First few layers of the network extract the discontinuities and the further layers combine these discontinuities to form the features describing the input images. Also in contrast to fully connected layers in Back Propagation Network (BPN), the connection is sparse i.e not all the neurons in the previous layers are connected to all the neurons in the next layers. This sparseness protects the network from overloading. Once the features are extracted, positive values are retained as such and all the negative values are converted to zeroes using Rectified Linear Unit (ReLU). Reduced feature map is then obtained using pooling layers.

## 2. Related Work

In CNN, based on the filters used for convolution, the number of layers, fully connected networks, multiple CNN architectures like ALEXNET, GOGLENET, VGGNET, RESNET, DENSENET, SQUEEZENET sprang into existence. ThiThanhNhan Nguyen et al (2016) found that Googlenet is the best suited architecture for flower database classification with an accuracy of (90.82%). Y. Liu et al (2016) achieved an accuracy of 84.2% with their own CNN architecture that had three fully connected networks. Abu et al (2019) achieved an accuracy of 90% classification for flower database classification with their own CNN model. However, only five sets of flowers were considered for classification. I. Gogul and V. S. Kumar (2017) proved that CNN outperforms conventional feature extraction and classification algorithms for flower database. Arwatchananukul (2020) used CNN for the classification of 15 types of orchids. The sample size was 100 for each type amounting to a total of 1500 images. Accuracy of classification is greater than 95%. It is thus necessary to come out with a CNN architecture that outperforms the networks cited in the literature for a very large dataset.

## 3. Research Database

In this work, flower dataset is taken which consists of 102 (one hundred and two) different categories of flowers used for processing and classification based on extracted features. Each category is named as A1, A2... and so on till A102. Each category consists of certain number of images with a minimum of 20 each in every category. On a total, there are 8189 flower images in 102 categories. The same dataset is used for all the different types of Convolutional Neural Networks (CNN). 50% of the dataset is used for training and 50% is used for testing. Dataset is stored in hadoop file system

where hadoop is used for storing the database from where it is used for training and testing the neural networks.



Figure 1.Images from flower database (Courtesy: [https:// www.robots.ox.ac.uk/~vgg/ data/ flowers](https://www.robots.ox.ac.uk/~vgg/data/flowers))

#### 4. CNNFor CBIRof Images From Hadoop

In this work, a hadoop cluster with 8 systems is created with one as the master node and the remaining 7 (seven) as slave nodes. In master there is no data node to store the data only slave nodes will have data node to store data. Every operation has to be done only in master system. Master node consists of metastore which have all information about data where it has stored. Figure 2 shows the details of cluster.

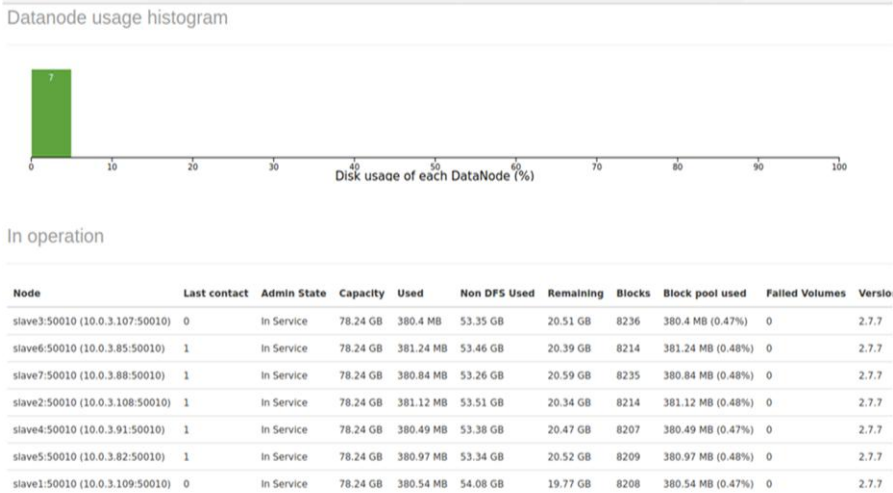


Figure 2.Details of the cluster

##### 4.1. Convolutional Neural Networks for flower database classification

In this work, VGGNET, RESNET and DENSENET are used for the classification of flower images. All these networks use convolutional layers followed by activation layer (Rectified Linear Unit) and pooling layers. At the end, a fully connected network

is used for classifying the flowers into groups. An overview of these networks is given in Table 1. Irrespective of the size of the original images, all the images are augmented as 224x224x3. It means that all the input images are resized with 224 rows, 224 columns and are three dimensional (colour images). It simplifies the convolution operation when a common filter is applied across each and every element.

**Table 1.**VGGNET, RESNET and DENSENET – An Overview

<b>Name of the network</b>	VGG16	VGG19	RESNET 101	RESNET 50	RESNET 18	Densenet201
Number of layers	16 layers deep	19layers deep	101 layers deep and can classify images into 1000 object categories	50 layers deep and can classify images into 1000 object categories	18 layers deep and can classify images into 1000 object categories	201 layers deep and can classify images into 1000 object categories
Input to the subsequent convolutional layers	Input is received only from the immediately preceding layer (no short cuts)	Input is received only from the immediately preceding layer (no short cuts)	Input is received only from the immediately preceding layer (with short cuts)	Input is received only from the immediately preceding layer (with short cuts)	Input is received only from the immediately preceding layer (with short cuts)	Input is received from all the preceding layers
Transition layer operation	Sum of residues (element wise addition)	Sum of residues (element wise addition)	Sum of residues (element wise addition)	Sum of residues (element wise addition)	Sum of residues (element wise addition)	Concatenation of feature maps (feature map operation)
Pooling layers	Every convolution layer has a pooling layer	Every convolution layer has a pooling layer	Only two pooling layers (one at the beginning and the other at the end)	Only two pooling layers (one at the beginning and the other at the end)	Only two pooling layers (one at the beginning and the other at the end)	Every convolution layer has a pooling layer
Speed	Slow	slow	Fast	fast	fast	fastest

Performance of the above said networks on the classification of flower database is shown in Table 2 for test images of f1 category. There are mismatches between the desired and the actual outputs of the Convolutional Neural Networks used in this work. Overall performance of the networks for the classification of test images is measured in terms of accuracy and is given in Table 2

**Table 2.** VG Relationship between actual and predicted classes for fl from various CNN architectures

Desired	Column2 VGG16	Column3 VGG19	RESNET18	RESNET50	RESNET101	Densenet201
fl	f45	f64	fl	f55	fl	fl
fl	fl	fl	f51	fl	f51	fl
fl	fl	fl	f93	fl	f93	fl
fl	fl	fl	fl	fl	fl	fl
fl	fl	fl	f86	fl	f86	fl
fl	fl	fl	f51	fl	f51	fl
fl	f97	f51	fl	fl	fl	fl
fl	f34	fl	fl	fl	fl	f95
fl	f53	f96	f40	fl	f40	fl
fl	fl	fl	f86	fl	f86	f53
fl	f96	fl	f51	f34	f51	fl
fl	f53	f51	f51	fl	f51	f98
fl	f96	f51	f40	fl	f40	fl
fl	f97	f51	fl	fl	fl	fl
fl	f98	f86	fl	f51	fl	f98
fl	fl	f86	fl	fl	fl	f98
fl	f34	f86	fl	f51	fl	fl
fl	f67	f51	fl	f51	fl	fl
fl	fl	f86	f51	f51	f51	fl

**Table 3.** Performance of Convolutional Neural Networks for the classification of flowers in flowers database

Parameters	VGG16	VGG19	RESNET18	RESNET50	RESNET101	Densenet201
No. of matches	3362	2694	3443	3656	3633	3770
No. of mismatches	708	1376	627	414	437	300
Total no. of images	4070	4070	4070	4070	4070	4070
Accuracy in percentage	82.6%	66.19%	84.59%	89.8%	89.2%	92.6%

From the last row of Table 3, it is evident that DENSENET outperforms other networks in classifying the flower images with an accuracy of 92.6% as it considers concatenation of feature mapping instead of summation.

## 5. Conclusion and Future Work

In this work, feasibility of Convolutional Neural Networks for the classification of flower images is studied. Of the various Convolutional Neural Network architectures,

VGG16 has an accuracy of 82.60% respectively. VGG19 has accuracy of 66.19% respectively. DENSENET201 has an accuracy of 92.6% respectively. RESNET18 has an accuracy of 84.59% respectively. RESNET50 has an accuracy of 89.8% respectively. RESNET101 has an accuracy of 89.2% respectively. For the classification of flower dataset, Densenet201 has the highest accuracy. Though the proposed algorithms are scalable in nature, the impact of large dataset on the performance of the proposed techniques can be studied. The work has stopped at simulation level. Also new architectures and image specific improvements can be made in the existing techniques to improve the performance of the network.

## References

- [1] Nguyen, Nhan & Le, Van & Le, Thi & Hai, Vu & Pantuwong, Natapon & Yagi, Yasushi. (2016) Flower species identification using deep convolutional neural networks. Proc. of Regional Conference on Computer and Information Engineering (RCCIE 2016)
- [2] Liu.Y, Tang.F, Zhou.D , Y. Meng and W. Dong. Flower classification via convolutional neural network. 2016 IEEE International Conference on Functional-Structural Plant Growth Modeling, Simulation, Visualization and Applications (FSPMA), Qingdao, 2016, pp. 110-116, doi: 10.1109/FSPMA.2016.7818296.
- [3] Abu, MohdAzlan & Indra, NurulHazirah & AbdRahman, Abdul & Sapiee, Nor & Ahmad, Izanoordina. (2019). A study on Image Classification based on Deep Learning and Tensorflow. 12. 563-569.
- [4] Gogul and V. S. Kumar. Flower species recognition system using convolution neural networks and transfer learning. 2017 Fourth International Conference on Signal Processing, Communication and Networking (ICSCN), Chennai, 2017, pp. 1-6, doi: 10.1109/ICSCN.2017.8085675.
- [5] Arwatchananukul, Sujitra & Kirimasthong, Khwunta & Aunsri, Nattapol. (2020). A New Paphiopedilum Orchid Database and Its Recognition Using Convolutional Neural Network. Wireless Personal Communications. 115. 10.1007/s11277-020-07463-3..
- [6] Ambeth Kumar.V.D, S. Sharmila, Abhishek Kumar, A. K. Bashir, Mamoon Rashid, Sachin Kumar Gupta & Waleed S. Alnumay .A novel solution for finding postpartum haemorrhage using fuzzy neural techniques. Neural Computing and Applications (2021) (<https://doi.org/10.1007/s00521-020-05683-z>)
- [7] AnkitKumar,VijayakumarVaradarajan,AbhishekKumar, PankajDadheech, SurendraSinghChoudhary, V.D. AKumar, B.K.Panigrahi, KalyanaC.Veluvolug, “ Black hole attack detection in vehicular ad-hoc network using secure AODV routing algorithm”,Microprocessors and Microsystems, In Press,(<https://doi.org/10.1016/j.micpro.2020.103352>)
- [8] Ambeth Kumar S. Malathi R. Venkatesan K Ramalakshmi, Weiping Ding, Abhishek Kumar . Exploration of an innovative geometric parameter based on performance enhancement for foot print recognition. Journal of Intelligent and Fuzzy System , vol. 38, no. 2, pp. 2181-2196, 2020.
- [9] V.D.AK et al, (2016) .Human Life Protection In Trenches Using Gas Detection System. for the Journal of Biomedical Research. Vol.27 (2): 475-484
- [10] Malathi .S et.al .Performance Improvement Using an Automation System for Segmentation of Multiple Parametric Features Based on Human Footprint.”,Journal of Electrical Engineering & Technology , vol.10, no.4, pp.1815-1821, 2015. [<http://dx.doi.org/10.5370/JEET.2015.10.4.1815>]
- [11] V.D.Ambeth Kumar et,al, “Enhancement in Footprint Image using Diverse Filtering Technique” Procedia Engineering journal, Volume 8, No.12, 1072-1080, 2012 . [doi:10.1016/j.proeng.2012.01.965]
- [12] S.V. Ruphitha et.al, “ Management of Major Postpartum Haemorrhage by using Zigbee protocol - A Review “, 2021 6th International Conference on Inventive Computation Technologies (ICICT) (DOI: 10.1109/ICICT50816.2021.9358757 )
- [13] M. Indhumathi et.al , “Healthcare Management of Major Cardiovascular Disease-A review”, 2021 6th International Conference on Inventive Computation Technologies (ICICT), (DOI: 10.1109/ICICT50816.2021.9358519 )
- [14] K. Sabarinathan et.al ., “ Machine Maintenance Using Augmented Reality”, 3rd International Conference on Communication and Electronics Systems (ICCES), 2018. (DOI: 10.1109/CESYS.2018.8723900)

# Clinical Data Based Classification of Osteoporosis and Osteopenia Using Support Vector Machine

Ramesh.T<sup>a,1</sup> and Santhi.V<sup>b</sup>

<sup>a</sup> Research Scholar, Dept of CSE, Vellore Institute of Technology, Vellore, India

<sup>b</sup> Professor, Dept of CSE, Vellore Institute of Technology, Vellore, India

**Abstract.** In the current world millions of people are suffering with bone diseases such as osteoporosis and osteopenia. The early detection of osteoporosis and osteopenia disease is very important as it helps people to be cautious and get treated on time. Hence research on early detection of osteoporosis and osteopenia disease has gained importance across the world. In this paper, analysis of suitable kernel for Support Vector Machine (SVM) focussing on the classification of osteoporosis and osteopenia disease has been carried out and presented. The kernel functions considered includes polynomial, linear, RBF and Gaussian to find the optimal one for the classification of osteoporosis and osteopenia disease with improved accuracy.

**Keywords.** Osteoporosis; Osteopenia; Data Mining; Big Data; SVM; Health care

## 1. Introduction

Due to change in food habits, lack of physical activities and aging factor, people are often getting affected with diseases. In this way, the osteoporosis is considered as one of the critical diseases that affects bones severely, due to low Bone Mass Density (BMD) [1]. If this kind of disease is not diagnosed at the earlier stage, in due course of time low BMD may lead to bone fracture too. In general, all women after their menopause stage and all men who have crossed age of 50 will be affected with this low BMD due to the stoppage of increasing bone density level. As bones loses its density, chances of getting bone fracture increases, and become quite common among aged people. The bone density can be measured clinically and its value can be used as a measure for further treatment. The clinically measured BMD value is called T-Score [2], and it is based on bone mineral content that reveals out bone mineral density. In general, the value of T score goes down if the calcium and iron minerals content goes down in human bodies due to vitamin-D deficiency.

In literature, there are many classification techniques exists for the prediction of various disease in health care sector that include Support Vector Machine (SVM), Logistic Regression (LR), Artificial Neural Networks (ANN) etc. Support Vector Machines is considered as one of the efficient classification techniques among various learning methodologies. Basically SVM is designed for binary classification problems

---

<sup>1</sup>Santhi.V, Professor, Dept of CSE, Vellore Institute of Technology, Vellore, India.  
Email:vsanthi@vit.ac.in.



where decision boundaries can be used by splitting classes into two categories, but in recent days there is huge requirements for multi class classification in healthcare sector [3]. SVM can be applied for multi class classification by sub dividing multiple classes into two-class problems. As SVM keeps dividing data into two class problems in multiple times, it finds a new hyper planes which minimizes misclassification errors, and also based on the size of the data, the testing and classification time varies in SVM. Hence to minimize the testing time various kernel functions such as RBF, Polynomial etc. can be applied over SVM [4].

In SVM, positive and negative classes will be separated by their regions very effectively compared to other learning techniques. In healthcare SVM plays a vital role in predicting various diseases such as Alzheimer, where the estimation of life logging data need to be extracted in order to bring memory back to the Alzheimer patient. The same manner, SVM technique can be applied over other diseases in order to bring out confidential information for the prediction of diseases. In mobile healthcare systems a multicast routing can be applied using algorithms such as AdaBoost with SVM classifier, in order to enhance the dependability and scalability in a secured manner [5]. Apart from this Multi SVM would be much more effective in prediction of breast cancer and different types of cancer. In general SVM Technique is very simple as it prefers binary classification at multiple levels of SVM when it comes to multi class classification. In the process of predicting Osteoporosis and Osteopenia, there are various algorithms applied over radiographic images using Principal Component Analysis (PCA) and SVM etc.[6] [7]. In general bone mineral density plays a vital role in the prediction of osteoporosis and osteopenia diseases. The low bone mass density refers to osteopenia, whereas severe loss of bone mass density leads to osteoporosis. By extracting various features from radiographic images, the Osteoporosis and Osteopenia diseases can be classified by applying various statistical measurements over bone mineral density. The bone mineral density can be measured especially for women who cross post-menopausal stage at different states such as walk and rest in order to predict Osteoporosis based on T-score values by selecting relevant features using Principal Component Analysis (PCA) [8]. These predictions will help women to be cautious about decrease in bone mineral strength as it leads to Osteoporosis.

Section 2 discusses about related works carried out on Osteoporosis and Osteopenia disease classifications. Section 3 includes methodology which deals with multi-level SVM in the process of prediction of osteoporosis and osteopenia and also description about the datasets being used to analyze classification approaches. Section 4 deals with experimental setup and obtained results.

## 2. Related works

In this section, a detailed of study of literature has been carried out, related to classification of Osteoporosis and similar type of diseases in healthcare using machine learning approaches such as support vector Machine (SVM) etc. Madhumita Kathuria et.al have proposed Wireless Body Area Networks (WBAN) for taking decision on patient's health related data which is versatile in nature. If data are heterogeneous in nature, classifying those data with high accuracy a major challenging as it contains more sensitive information. In order to overcome this situation, Support Vector Machines for multi class classification would be very appropriate accurate packet classification as it deals with various types packets based on priority. The SVM packet classification can

be done at central controller effectively. Here throughput of Wireless body Area Network system is less as packet delivery rate is low [9]. Alanazi et.al have proposed a predictive model in order to categorize various types of diseases using multi class classification to achieve better performance using the traumatic brain injury (TBI) datasets [3]. In general the accurate prediction refers to identification of diseases from historical data and it will help doctors to provide effective treatment as it will be aimed at multi class classification rather than binary classification. But this predictive model could be suitable for TBI outcomes and not for other diseases. Ilaria Bortone et.al have proposed a supervised approach to predicate postmenopausal women's BMD status based on alimental habits, lifestyle and precedent fractures [14]. In this approach, a detailed analysis of static and dynamic baropodometry will cull the pertinent features through the Principal component analysis (PCA). These two supervised classifiers, such as static and dynamic baropodometry, have proved to be a promising tool for screening both bone and muscle function declines. This approach can only deal with BMD rather than predicting the diagnosis of Osteoporosis. Ramkumar et.al have proposed a model aimed at the classification of Osteoporosis and Osteopenia by making use of radiographic bone images [8]. In this model, through the segmentation of abnormal areas of images, bone disorder can be predicted. In this approach, text-based features are extracted using Gray-Level Co-occurrence Matrix (GLCM) in segmentation. The usage of radiographic images can easily observe the changes in the structure of bone due to bone disorder. In order to reduce the size of the features in bone images Principal Component Analysis can be applied. Finally Multi class Support Vector Machine will classify the bone disorders using feature vectors. Devikanniga et.al have proposed a hybrid classifier model using Monarch butterfly optimization algorithm through Artificial Neural Network (ANN) classifier for early diagnosis that lead to the prevention of Osteoporosis [13]. This hybrid classifier can easily distinguish Osteoporotic patient and healthy person based on the values of BMD. This model has been applied on femoral neck and lumbar spine datasets for predicting the accuracy of diagnosing Osteoporosis. This hybrid classifier model is not suitable for high dimensional medical data classification. Victor Blanco et.al have proposed a novel SVM-based approach towards constructing multi-class classifiers in terms of arranging hyper planes using mixed integer programming by adopting suitable kernel [14]. It can be used to handle multi class classification by extending binary SVM classifiers. In this approach, it finds a polyhedral partitioning of the space feature and assigning classes to partition the cells by maximizing the separation between classes and minimizing two intuitive misclassification errors. But the computational burden is high for complex mixed integer programs. Yassine Naseer et.al focuses on diagnosing Osteoporosis from bone X-ray images by extracting features from low level images using deep learning approach [25]. The major challenge in diagnosing Osteoporosis was addressed here such as distinguishing a person who is osteoporotic and healthy from X-ray images. In order to tackle this issue, the proposed technique performs pre-processing in series of steps to upgrade the contrast of the image, image region with sliding window activity, feature extraction followed by stacked sparse Autoencoder and finally pooling activity followed by classification step using SVM classifier. Based on the literature survey, it is identified that many works have been carried out to diagnose Osteoporosis using radiographic images rather than bone mineral density values. It is observed that binary classification using SVM have been carried out in diagnosing Osteoporosis but not on Osteopenia. Also Multi level classification in diagnosing Osteoporosis and Osteopenia is lagging. All these research gaps are addressed in this paper.

### 3. Materials and Methods

Dataset has been gathered from the Disease Control and Prevention (CDC) centre which has created dataset through National Health and Nutrition Examination Survey (NHANES III) as a part of National Center of Health Statistics (NCHS). The data are retrieved from two file types, they are Demographic Data File (DDF) and Examination Data File (EDF). The required and relevant attributes are retrieved from these above said files. World Health Organization (WHO) and IOF suggest the NHANES database values as the standard reference group for classifying the said disease using BMD. The WHO suggests that non-Hispanic white women age in the range between 20 and 29 years have participated in NHANES III (1988-1994) as the reference group for the computation of T-score in the femoral neck and lumbar spine. The reference group data of NHANES is utilized as a base to find the T-score using BMD values [9] [10].

**Table 1.** WHO definition of osteoporosis based on BMD measurements from DXA

Definition	Bone Mass Density Measurement	T-Score Range
Normal	$\mu: \sigma < 1$	$\geq -1$
Osteopenia	$\mu: 1 \leq \sigma < 2.5$	$-1 < -2.5$
Osteoporosis	$\mu: \sigma \geq 2.5$	$\leq -2.5$

In Table 1, the category of disease is presented with the corresponding T score values. In osteoporosis classification, samples with T-score values above -1 are labeled as non-osteoporotic and normal category. Similarly, if calculated T score value lies between -1 and -2.5, then it is classified as osteopenia, and if the T-score value less than or equal to -2.5 are considered as osteoporotic. [11] [12]. The dataset has been analyzed by medical experts and it has 10 input variables such as weight, standard height, body mass index, gender, race, age in years, femoral neck BMD, femoral neck BMC, femoral neck area and T-Score values [13].

**Table 2.** Description of output attributes

Attribute	Name	Label	Description
		For SVM	
T-Score	Class	0	Normal Health Class
		1	Osteopenia Class
		2	Osteoporosis Class

The data set considered for study from NHANES is pre-processed before performing classifications. The pre-processing steps include data integration, data reduction, data cleaning, data transformation and data splitting. There are more than 100 irrelevant attributes have been found and removed in data reduction phase. The feature set is retained with 12 attributes which are needed for diagnosing osteoporosis and osteopenia. Min-max normalization method is adopted to normalize all the attributes as a part of data transformation process. Finally in data splitting process, the data set has been divided into two category with respect to age, then the T score measurements has been applied only if age value is above 50. Table 2 shows the expected outcome of multi-level SVM.

### 3.1 Multi – level SVM

The Support Vector Machine (SVM) classifier is a kind of machine learning algorithm that attempts to find an optimal hyperplane with maximum margin. This algorithm separates the linearly separable data samples into two classes [14]. If the data is non-linearly distinguishable, then SVM maps the data into high-dimensional feature space and performs the classification. where ‘W’ is the normal vector that represents the angle or orientation of the hyper plane in m- dimensional space (synonymously it can be called as width of the margin), ‘X’ represents the input vector and ‘b’ represents the bias or threshold that represents the position or the distance of the hyper plane from the origin as shown in Figure 1. In multi-level SVM, there can be two or more binary SVM’s can be used to classify data set into many classes. In this paper, 3 input data set has been divided into three classes namely class 0, Class 1 and class 2 that represents people with normal health, people affected with osteopenia and people affected with osteoporosis [15]. Initially in binary SVM, the data set has been classified into normal and diseased categories. The diseased categories can further be classified into osteopenia and osteoporosis using binary SVM.

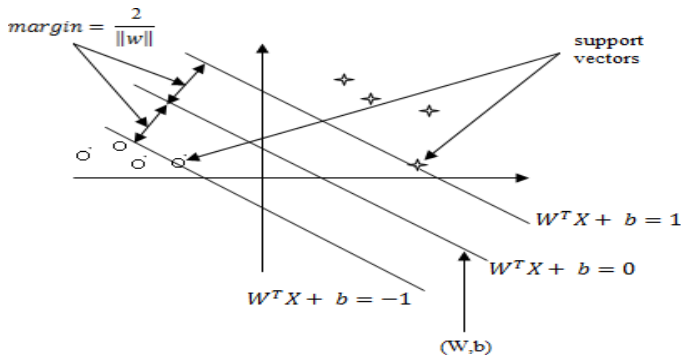


Figure 1. Working Model of SVM

In general SVM algorithms use different types of kernels in order to transform the input into required form; they are called as linear, polynomial, RBF and Gaussian. The detailed discussion on each kernel is presented below.

### 3.2 Polynomial Kernel

Polynomial kernel plays a vital role in learning of non-linear models. For identifying the similarity of vectors in training samples of kernelized models including Support Vector Machines, they make use of the polynomial kernel function. Learning of non-linear models can be done using polynomial kernel which works in feature space with polynomials of original variables and identifying the similarity of vectors. For degree-n polynomials, the polynomial kernel (2) is characterized where n represents order of the polynomial, a and b are vectors in the input space, i.e. vectors of features compared from training or test samples then  $c \geq 0$  is a parameter compromising the impact of higher-order versus lower-order terms in the polynomial.

### 3.3 Gaussian Kernel

Here  $\alpha$  chooses the width of the Gaussian and it is a function of Standard deviation and the square of Variance (3).

### 3.4 Radial Basis Function (RBF) Kernel

The RBF kernel is represented a RBF kernel decreases by distance in the range between zero (within limit) and one during estimation, and the feature space has an endless dimensions of this kernel.

### 3.5 Linear Kernel

Linear kernel can be defined by adding the inner product  $\langle a, b \rangle$  and the constant  $c$  which is optional. This particular kernel used by the kernel algorithms is similar to their non-kernel counterparts.

### 3.6 Exponential Kernel

This particular kernel is almost similar to Gaussian Kernel, without square of the norm. It is also a RBF kernel.

### 3.7 Laplace RBF Kernel

The Laplace Kernel is identical to the exponential kernel, aside from being less delicate for changes in the sigma boundary. Being same, it is also a RBF kernel. Note that the perceptions made about the sigma boundary for the Gaussian kernel can also apply to the Exponential in addition to Laplacian kernels.

### 3.8 Sigmoid Kernel

The sigmoid function can be used for artificial neurons as an activation function as Neural Network field produces sigmoid kernel. The sigmoid kernel is also known as the Hyperbolic Tangent Kernel, and also called as Multi-Layer Perceptron Kernel. As the sigmoid kernel evolves from neural network theory, it is playing significant role for Support Vector Machines. It is almost similar to perceptron neural network.

### 3.9 Anova Kernel

The Anova kernel is quite similar to RBF kernel, just like Laplacian kernel in addition to Gaussian kernels. In solving multidimensional regression problems this kernel plays a significant role compared to other kernels.

### 3.10 Proposed System Flow Diagram

The working model for the classification of osteoporosis and osteopenia using Multi SVM is shown in Figure 2. The required features would be extracted from input data set

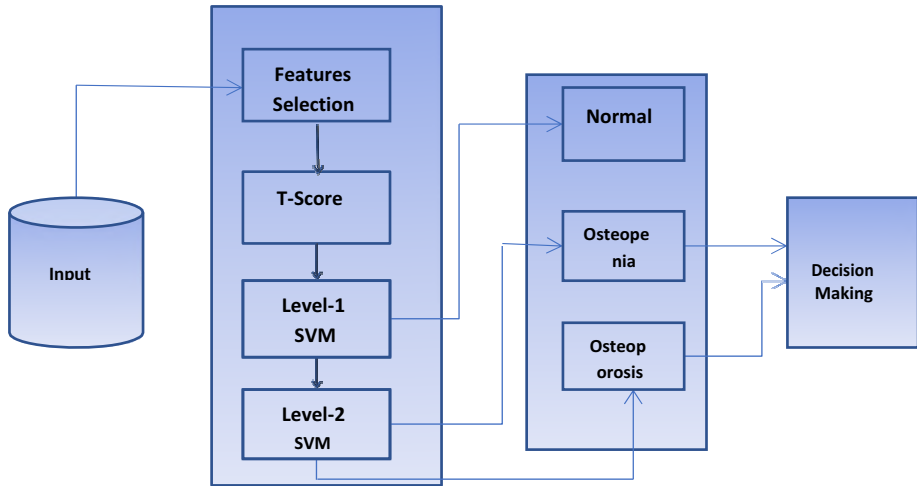


Figure 2. System Flow Diagram

and it would be used for T-Score calculations. The calculated values are given as inputs to SVM classify the diseases. In the first level of SVM, binary classification is carried out to diagnose a particular person to decide upon whether the person is affected with disease or not. If that person has disease then it will get into second level of SVM, where Input: Here the input has been taken from open source health related organization, where datasets are freely available as mentioned above. Here more than 100 input attributes are taken for processing such as Weight, Standing Height, Body Mass Index, Gender, Race, Age, and Femoral neck BMD etc. Later all these input attributes will go for features selection as it is very important to get the relevant attributes which are needed to calculate T-Score values. T-Score Calculation: In general T-Score (10) values need to be calculated using BMD values such as Here for each patient T-Score can be calculated using respective BMD value, mean and Standard Deviation of all BMD values which are associated to it.

#### 4. Experimental Results

The experiments are conducted in MATLAB using Multi SVM with different kernels such as Polynomial, Linear, RBF, and Gaussian. The femoral datasets has been considered to classify diseases into osteoporosis and osteopenia, and sample data set is shown in Table 3. The comparisons of kernels have been carried out and obtained results are shown in Table 4. The parameters considered are accuracy, sensitivity and specificity. The accuracy obtained using polynomial kernel is 93.20%, which is less compared to other kernels. Similarly the kernel which has given the highest accuracy is Gaussian kernel with the accuracy of 97.30% as shown in Figure 3.

Like accuracy, other parameters such as sensitivity of each kernel are calculated and it is found that Gaussian kernel has got more sensitivity of 96.30%. At last when it comes to Specificity, it is observed that polynomial kernel has lowest compared to other kernels, but at the same time Gaussian kernel has more sensitivity about 97.70%.

**Table 3.** Sample Data Set with extracted features

Weight (kg)	Standing Height (cm)	Body Mass Index (kg/m <sup>2</sup> )	Gender	Race/Ethnicity - Recode	Age in years	Femoral neck BMD	Femoral neck BMC	Femoral neck area	T-score	class
56.8	167.8	20.17	1	1	50	1.014	5.55	5.47	0.50	
65	156.6	26.51	1	1	50	0.934	4.67	5	-0.10	
87.4	171.7	29.65	1	1	50	0.931	5	5.37	-0.10	
108.8	174.2	35.85	1	1	50	0.725	4.26	5.88	-1.81	
75.5	169.8	26.19	1	1	50	0.779	3.92	5.04	-1.41	
81.4	173.2	27.13	1	1	50	0.813	4.03	4.96	-1.11	
51.2	164.9	18.83	1	1	50	0.949	4.95	5.22	0.00	
86.5	167.6	30.79	1	1	50	0.917	4.77	5.2	-0.20	
99.2	178.9	30.99	1	1	50	0.813	4.97	6.11	-1.11	
84.6	176.5	27.16	1	1	50	1.009	5.55	5.5	0.50	
111.9	190.7	30.77	1	1	50	0.976	5.99	6.14	0.20	
65.7	186.7	18.85	1	1	50	0.892	5.61	6.29	-0.50	

Like Accuracy, other parameters such as Sensitivity of each kernel are calculated and it is found that Gaussian kernel has got more Sensitivity of 96.30%. At last when it comes to Specificity, it is observed that polynomial kernel has lowest compared to other kernels, but at the same time Gaussian kernel has more sensitivity about 97.70%.

**Table 4.** Comparison of kernels with qualitative parameters

	Accuracy	Sensitivity	Specificity
Polynomial	93.20%	93%	93.20%
Linear	94.40%	94.40%	94.50%
RBF	95.30%	95.30%	95.70%
Gaussian	97.30%	96.30%	97.70%
Exponential	92.30%	92.50%	92.30%
Laplace RBF	91.30%	91.40%	91.10%
Sigmoid	95.90%	95.40%	96.20%
Anova	90.60%	89.90%	90.30%

In this proposed multi class SVM based works; it is observed that the Gaussian kernel has given better results compared with other kernels such as polynomial, Linear and RBF in terms of accuracy, sensitivity and specificity. In the process of classifying osteoporosis and osteopenia using Multi SVM with the help of various kernel functions and it is found that Gaussian kernel provides better result compared to other kernels as shown in Table 4. Here the performance measurements such as accuracy, sensitivity and specificity are analyzed with all the kernels as mentioned in the Table 4.

## 5. Conclusion

In this paper, analysis of the kernel function for the classification of diseases Osteoporosis and Osteopenia using multi class SVM has been carried out. A list of kernels considered for the experiment includes linear, polynomial, RBF, exponential, sigmoid, Laplace RBF, Anova and Gaussian function. The three output classes are labelled as 0, 1 and 2, where class 0 represent people not affected with disease and

normal, class 1 represent people are affected with Osteopenia and class 2 represent Osteoporosis patients. The evaluated results show that the Gaussian kernel is giving better accuracy compared to other kernels in SVM. This proposed research work will be extended by cascading multi class SVM with other techniques for better performance in future.

## References

- [1] Sayantan Bhattacharya, Ayush Goyal et.al. Computer Based Automatic Detection and Classification of Osteoporosis in Bone Radiographs. ©2019 IEEE. Rice AS, Farquhar-Smith WP, Bridges D, Brooks JW. Cannabinoids and pain. In: Dostorovsky JO, Carr DB, Koltzenburg M, editors. Proceedings of the 10th World Congress on Pain; 2002 Aug 17-22; San Diego, CA. Seattle (WA): IASP Press; c2003. p. 437-68.
- [2] Devikanniga, R. Joshua Samuel Raj. Classification of osteoporosis by artificial neural network based on monarch butterfly optimization algorithm. Vol. 5, pp. 70–75.
- [3] Alanazi, A. H. Abdullah et.al .Accurate and dynamic predictive model for better prediction in medicine and healthcare.© Springer; July 2017.
- [4] Fereshteh Falah Chamasemani et.al. Multi-class Support Vector Machine (SVM) classifiers – An Application in Hypothyroid detection and Classification. © 2011 IEEE.
- [5] Maryam Sadat Hejazi, S. A. R. Al-Haddad et.al, Multiclass Support Vector Machines for Classification of ECG Data with Missing Values. 29:660–674; © 2015 Taylor & Francis Group.
- [6] Ying Wang, Enrico Coiera et.al.Using multiclass classification to automate the identification of patient safety incident reports by type and severity, BMC Medical Informatics and Decision Making (2017).
- [7] Saphthagirivasan V., Anburajan M, Diagnosis of osteoporosis by extraction of trabecular features from hip radiographs using support vector machine: an investigation panorama with DXA, Comput. Biol. Med., 2013, 43, pp. 1910–1919, (doi: 10.1016/j.compbiomed.2013.09.002).
- [8] Ramkumar S, Malathi R.An Automatic Bone Disorder Classification Using Hybrid Texture Feature Extraction with Bone Mineral Density. 19 (12), 3517-3523; Asian Pacific Journal of Cancer Prevention, Vol 19 (2018).
- [9] Madhumita Kathuria and Sapna Gambhir. A novel Optimization Model for Efficient Packet Classification in WBAN. International Journal of Energy, Information and Communications, Vol.7, Issue 4 (2016), pp.1-10.
- [10] Centers for Disease Control and Prevention (CDC), National Center for Health Statistics (NCHS). National Health and Nutrition Examination Survey Data, U.S. Department of Health and Human Services, Centers for Disease Control and Prevention, Hyattsville, MD, 2005.
- [11] S. Bhattacharya, D. Nair, A. Bhan, A. Goyal, Computer based automatic detection and classification of osteoporosis in bone radiographs, in: Proc. 6th Int. Conf. On Signal Processing and Integrated Networks (SPIN).IEEE, Noida, India, 2019, pp. 1047–1052.
- [12] Harrar, L. Hamami, S. Akkoul, E. Lespessailles, R. Jennane. Osteoporosis assessment using Multilayer Perceptron neural networks. in: 2012 3rd International Conference on Image Processing Theory, Tools and Applications, Istanbul, 2012, pp. 217–221.
- [13] Devikanniga.Diagnosis of osteoporosis using intelligence of optimized extreme learning machine with improved artificial algae algorithm. International Journal of Intelligent Networks 1 (2020) .
- [14] Ilaria Bortone, Gianpaolo Francesco Trotta et.al., Supervised Approach to Classify the Status of Bone Mineral Density in Post-Menopausal Women through Static and Dynamic Baropodometry. 978-1- 5090-6014; ©2018 IEEE.
- [15] Víctor Blanco, Alberto Japón et.al.. Optimal arrangements of hyperplanes for SVM-based multiclass classification. 2019 © Springer;
- [16] Felicia et.al. .The clinician’s guide to prevention and treatment of osteoporosis. Osteoporos, Int. 25 (2014) 2359–2381.
- [17] Iliou, C.-N. Anagnostopoulos, G. Anastassopoulos. Osteoporosis detection using machine learning techniques and feature selection. Int. J. Artif. Intell. Tool. 23, (2014) 1450014, 9pages.
- [18] Muller, K.-R., S. Mika, G. Ratsch, K. Tsuda, and B. Scholkopf. 2001. An introduction to kernel-based learning algorithms. IEEE Transactions on Neural Networks 12(2):181–201. doi: 10.1109/72.914517.
- [19] Devlin et.al, diagnosing osteoporosis by using dental panoramic radiographs: the OSTEODENT project.Oral Surg., Oral Med., Oral Pathol., Oral Radiol. Endod., 2017, 104, (6), pp. 821–828,



# A Reliable Cloud Based Framework for Large Scale Urban Sensing Systems

K.R.Jansi<sup>a,1</sup>, G.K.Sandhia<sup>b</sup> and Dr.S.V.KasmirRaja<sup>b</sup>

<sup>a,1</sup>Assistant Professor, Dept of CSE, SRM Institute of Science and Technology, Kattankulathur

<sup>b</sup>Research Supervisor, Dept of CSE, SRM Institute of Science and Technology, Kattankulathur

**Abstract:** The rising usage of smartphones and sensing models in today's life induces the development of large scale urban sensing networks in communication concepts. With the efficient implementation of people centric mobility models, the personal communication devices of people are acting as the sensor nodes that are capable of sensing the human behaviours and participating in framing the smart protocol designs for smart cities. Without the involvement of mobile users or people, the new protocols for mobility management, traffic management, environmental sensing and other applications become futile. The proposed cloud based model improves the reliability and scalability of the system with its multiple cloud servers design. The single point of failure can be resisted since many cloud servers belonging to a provider is used. So the framework remains fault tolerant in the presence of any server attacks. A standard homomorphic based encryption scheme is used for providing data confidentiality and also data is transferred anonymously improving the privacy of the system. The data aggregation process is supported by the model protecting the user's privacy. The performance analysis for the proposed framework is done in terms of design goal analysis and computation cost analysis.

**Keywords-** cloud framework, reliable, urban sensing, fault resistance

## 1. Introduction

In the past decade of communication technology over sensor networking and computations has provided an inclination in the field of wireless networking and communications. The researchers have developed the most effective wireless sensor networking with collection of embedded devices with resource constraints. The networking model has been applied for some specified applications in the field of industries and scientific developments includes weather forecasting, forest monitoring, military applications and for some other preventive maintenance. However these issues and applications are significant, the present tininess and consequent preamble of sensor Networks into general electronic devices such as PDAs, mobiles

---

<sup>1</sup>K.R.Jansi, Dept of CSE, SRM Institute of Science and Technology, India;  
Email: jansik@srmist.edu.in

and MP3 players, etc., has directed new trends of application prospects. Based on the appropriate architectural Framework of sensor platforms, the networks are influenced to solve issues on urban-scales or afford global data access to the common people. Simultaneously, the public are treated as individuals or in social groups can use this kind of networks for employing with some personal attention. With that note, a new technology has been developed as mobile people centric sensing. In the People Centric Sensing Networks (PCSN)[1], people based environmental sensing and acquisition of sensed data. Moreover, it can be defined as the combine mobility of people themselves that permits both observation coverage of huge public area with time and makes people as a curator of the device that observe required data about the life based patterns and communications [2]. This network can also be technically termed as opportunistic sensing networks that handle with events and communications between people.

## 2. Related works

This section narrates the existing works that are available in providing secured framework and also schemes on providing privacy during data aggregation in PCSN is discussed. Prisense [5] is the privacy preserving data aggregation model developed for people centric sensing networks. The model worked on the basis of data slicing and mixing method. Furthermore, the model used three strategies for node head selection, Random cover selection process, 1-hop method and h-hop method. Verifiable Privacy-preserving Aggregation (VPA) [6] worked on data slicing and data mixing process to handle the privacy of user provided data and for shared data integrity. VPA approach also performed both additive and non-additive functions of data aggregation. The VPA model was performed with several rounds with two way communications between the aggregation server and the sensors. This might process with higher transmission delays in the defined network. Also, when found a node failure or link failure, the model was not efficient to process with fault tolerance. Further, the model was not attacks resistive. The survey work presented in [7], [8] and [9] discussed about the adversaries and countermeasures for various attacks on urban sensing network. The attack models and mitigation techniques were discussed with effective data distribution strategies[11].

## 3. Framework



**Figure 1.**Reliable Framework for people centric sensing network

The system framework of the defined people centric sensing network is given in Figure 1. As mentioned in the Figure, the framework of the defined network contains trusted management centre, Aggregation cloud servers and mobile participants. The people centric sensing network is framed with number of mobile nodes that are connected with the access points. The access point's acts as a gateway to forward the data and also performs some aggregation functions. Further, there are number of cloud servers meant for handling the data in the cloud. They collude with each other cloud servers if there is task from trusted centre for summarization of data. So, aggregation service is also done by the cloud servers whenever statistical data is needed. The trusted management centre handles the mobile node registration in the network and authorization of cloud servers. They also act as security key distribution server and are assumed to be trusted entity. They provide the data obtained from mobile nodes to the data consumers and provides application oriented services based on requirements.

### 3.1 Execution phase of the Framework

#### 3.1.1 Network Initialization and Authorization

Here, the network initialization is defined with variety of network mobile nodes and cloud servers and that is linked with the Internet to process proper network communication without failures. The network Initialization and Authorization functions are handled by the Trusted Authority centre. The network is initialized with installation of web or mobile application developed for the purpose of collecting urban sensing data. Then the network mobile participants and cloud servers are authenticated on request basis by the trusted authority. Once the entities have joined the network, the trusted authority distributes the security key to the authorized mobile nodes and cloud servers for secured communication over the network. It is explicit that the model provides authentication, data privacy and security over shared data using homomorphic encryption based key generation. Let us consider the basic additively homomorphic encryption scheme for providing privacy preserved data communication using the pseudo random function.

#### 3.1.2 Key Initialization

The decryption key for the trusted authority centre is set using random selection of DecKey from  $\{0, 1\}^\lambda$  where  $\lambda$  is the product of two times the length of the output bits sent from random function. The encryption key for the each mobile nodes is fixed as  $\text{EncKey} = \text{random}_K(i)$  Where  $i$  represent the mobile participant node from 1 to  $n$ , the random function used belongs to the pseudo random function family.

#### 3.1.3 Privacy preserving Encryption

The data sensed by each mobile participant is transmitted in encrypted form for secured data communication. Also to protect the privacy of user's data, homomorphic encryption method can be used. The mobile node encrypts the data with the key set using random function. A Homomorphic encryption method allows doing arithmetic computations in cipher text form. This makes the access points to do aggregation on cipher text making them unaware about the plain text user data. By this method,

privacy of sensitive data shared by users is not revealed directly to any of the entities involved in the network communication. The encryption formula used is,

$$\text{Cipher} = \text{Encrypt}(\text{Msg}_i) = \text{Msg}_i + h(f_{\text{EncKey}}(\text{id})) \bmod M \quad (1)$$

$$\text{Meta} = \{i\} \text{ and Cipher report} = \{\text{Meta}, \text{Cipher}\} \quad (2)$$

Where  $\text{Msg}_i$  is the message sensed by  $i^{\text{th}}$  mobile participant,  $h$  depicts the hash function and  $f$  depicts the pseudo random function,  $\text{id}$  represents unique message ID and  $M$  is the modulus. Along with the encrypted message of the plain text, Meta information is also sent and formed as a report. The Meta information about the reporting node is combined for forwarding the report. The access points can find the aggregation on ciphers obtained from various mobile participants. Additive aggregation operation on cipher text is implemented along with combining the list of Meta information received from mobile nodes. Finally the cipher report is prepared by the access points and now it is ready for forwarding purpose.

#### 3.1.4. Secured Anonymous data communication

Anonymity can be achieved by hiding the relation of the identity of the sender and the receiver. This can be done by using Mix scheme for secured anonymous data communication in the network where there are many intermediate entities involved in the system. This standard scheme allows us to protect the data using RSA encryption methods. There are many intermediate nodes said as mix nodes along the network which forwards the message to the server. Finally, the trusted authority centre implements the decryption operation. Once the aggregated data is decrypted, the authority centre can now get the sum of plain text. The computation used for decryption is given in eqn 3 Where Aggregate is the final aggregated plain text,  $h$  depicts the hash function and  $f$  represents the pseudo random function,  $\text{id}$  represents unique message ID and  $M$  is the modulus.  $\text{Aggregate} = \text{Decrypt}(\text{cipher}) = \text{cipher} - \sum h(f_{\text{EncKey}}(\text{id})) \bmod M \quad (3)$

#### 3.1.5. Fault Resistance

There are many cloud servers in the system and they belong to the same cloud provider. Aggregation services also may be applied on the cloud servers for performing any aggregations. The main use of cloud servers are storage of huge data gathered from mobile participants. They collude with each other cloud servers if there is task from trusted centre for summarization of data. So, aggregation service is also done by the cloud servers whenever statistical data is needed. Otherwise, it provides the individual users data in cipher text whenever trusted authority demands for data once the task arrives. Multiple cloud servers are deployed in the framework for workload sharing and Fault tolerance. Also the data is stored in the encrypted form achieving data confidentiality and privacy. The single point of failure can be resisted since many cloud servers belonging to a provider is used. Let us consider an adversary attempting to compromise on a server, there are other cloud servers available to resist the communication of the network. The cloud servers are powerful entities and not much easy to compromise by any adversary. So, only minority of servers may be identified with risk, remaining percentage of servers may balance the load and resist on fault identified in the network.

#### 4. Performance Evaluation

**Security:** The communication model set in the framework is encrypted and secured against internal and external attacks. The model is resistant to attacks such as eavesdropping, false data injection and collusion attack. **Privacy:** Users privacy is protected because of the use of homomorphic encryption methods for privacy preserving aggregation. Also anonymity is achieved with the extension of mix scheme for communication between the intermediate entities available in the system. **Fault Tolerance:** The design of multiple cloud servers to balance work load sharing and fault tolerance. They also perform aggregation operations based on request from the trusted authority centre. **Computation Cost Analysis:** The computation cost analysis includes the cost of addition and multiplication operation under Modulus. Then the cost for generation of random key using pseudorandom function family is included along with the cost of implementation of hash functions. The computation cost for decryption by the trusted authority to generate the aggregate is also calculated.

#### 5. Conclusion

This paper proposes a cloud based framework for people centric urban sensing networks. The framework includes the mobile participants, aggregation cloud servers and trusted authority centre. The activities involved in transferring a data from mobile participants to application providers are divided into four phases such as Network Initialization and Authorization, Privacy preserving Encryption, Secured Anonymous data communication and Fault Resistance. A standard homomorphic based encryption scheme is used for providing data confidentiality and also data is transferred anonymously improving the privacy of the system. The cloud based network model improves the reliability of the system and also supports large scale sensing applications.

#### References

- [1] A. T. Campbell, S. B. Eisenman, N. D. Lane. The rise of people-centric sensing, *IEEE Internet Computing*. Vol.12(4), pages.12–21,2008.
- [2] Marco Conti, Silvia Giordana. Mobile Ad Hoc Networking: Milestones, Challenges, and New Research Directions, *IEEE Communications Magazine*, Vol.52 (1), pages.85-96, 2014.
- [3] R.K.Ganti, F.Ye, H.Lei. Mobile crowd sensing: current state and future challenges. In *IEEE Communications Magazine*, Vol.49(11), pages. 32-39,2011.
- [4] J. Shi, Y. Zhang, Y. Liu. Prisenze: privacy-preserving data aggregation in people-centric urban sensing systems. *Proceedings of IEEE INFOCOM: San Diego, CA, USA*, pages.1-9,2010.
- [5] Zhang R, Shi J, Zhang Y. Verifiable privacy-preserving aggregation in people-centric urban sensing systems. *IEEE Journal on Selected Areas in Communications*, Vol. 31(9), pages.268–278, 2013.
- [6] De Cristofaro E, DiPietro R. Adversaries and countermeasures in privacy-enhanced urban sensing systems. *IEEE Systems Journal*, Vol.7(2), pages.311–322, 2013.
- [7] K.R.Jansi, S.V.KasimRaja. A survey on Privacy Preserving data aggregation schemes in People centric sensing systems and wireless domains. *Indian journal of science and technology*, Vol 9(37), pages.1-7, 2016.
- [8] ZilengWei, Baokang Zhao, Yujing Liu, JinshuSu, PPSense. A novel Privacy-Preserving system in people centric sensing networks. *IEEE International conference on communications and Networking: China*, 2013.

- [9] K.R.Jansi, S.V.KasmirRaja,G.K.Sandhia. Efficient privacy-preserving fault tolerance aggregation for people-centric sensing system. Springer. Service Oriented Computing and Applications.Vol.12(34), pages. 305-315, 2018.
- [10] Arulprakash, M. Dynamic evolutionary information diffusion over mobile social networks . ARPN Journal of Engineering and Applied Sciences, 2016, 11(19), pp. 11457-11464.
- [11] AnkitKumar et.al., Black hole attack detection in vehicular ad-hoc network using secure AODV routing algorithm.Microprocessors and Microsystems, (<https://doi.org/10.1016/j.micpro.2020.103352>)

# Design of Prosthetic Arm

R. Swetha<sup>a,1</sup> and S. NirmalaDevi<sup>b</sup>

<sup>a</sup>Student, Dept of Medical Electronics

<sup>b</sup>Professor, Dept of ECE, Centre for Medical Electronics,  
Anna University Campus, Chennai, India

**Abstract:** This paper proposes the design of the prosthetic arm by reconstructing the structure and proportions of an amputated arm using high precision methods and dimensions. To achieve this, CT images of the patient's amputated and non-amputated arm are collected from the Rehabilitation centre. The patient CT data were imported to a 3D modelling software i.e., Mimics Innovation Suite version 22.0 Materialise 3-Matic version 14.0 original licensed software. The exported file is given to the Computer-Aided Design software, the geometry of the socket and the prosthetic arm were designed according to the mirrored geometry of the non-affected arm. 3D rendering for various degrees of movement has been carried out for animation.

**Keywords:** CT images, Thresholding, 3D part calculation, CAD design, Animation.

## 1. Introduction

For humans, the hand is a very important interface. Many interactions take place manually, including the manipulation of objects, interactions, and many other daily tasks [11]. When a human loses his or her limbs, these may be replaced by biomechanical devices such as orthotics and prosthetics [2]. In biomechanics, there is a variation between orthotics and prosthetics. The prosthesis is an artificial device that replaces a missing portion of the body that may be removed due to trauma, illness, or congenital disorders. Orthotics is a device used to help the limbs, or skeletal parts that are weak, ineffective, deformed or hurt. In the traumatic and sudden loss of the upper limb, the psychological effect is often even more intense [7].

It has been made physically more obvious by the upper limb deficiency and the limb presentation is also esthetically uncomfortable because of trauma impact. A prosthesis hand will restore some of a lost limb's positions and assist users with their everyday work [12]. The goal is to make sure that prosthesis and orthotics systems are human-centered and adaptable to the personal and environmental needs of any customer [9]. Measuring customer satisfaction with the prosthesis of the upper limbs and listing design goals for future innovations [8]. A voluntary, self-administered survey has gathered knowledge on the demographics, history, and aims of the prosthesis, comfort, and design goals for the participants. The human control mode is one feature of prosthesis control that makes it exceptional relative to traditional.

---

S. NirmalaDevi<sup>b</sup>, Professor, Dept of ECE, Centre for Medical Electronics, Anna University campus, India.  
Email:nirmala\_devi@annauniv.edu.

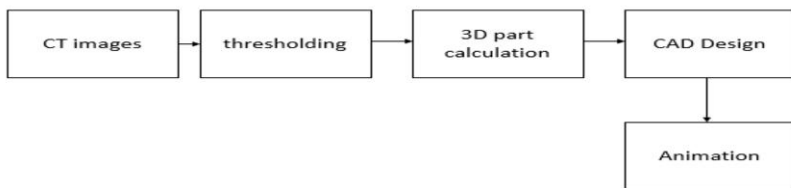
The prosthesis is an artificial extension that substitutes a missing portion of the body such as the upper or lower extremity of the body. An artificial limb is a form of prosthesis that replaces a missing limb, such as arms or legs. The type of artificial limb is selected based on the degree of the amputation or loss and the location of the missing portion of the body. There are two major types of artificial upper extremities. This human-machine systems. Although the user communicates with the computer with the hands or feet in common to all human, this is not the case with most human-prosthetic systems [5]. However, it is uncommon to see commercial use of hand movements in computer-aided sketching and modeling [1]. involves Transradial and Trans Humeral Prosthesis [5] Trans radial prosthesis is used to replace the arm that is absent below the elbow. In the prosthetics industry, the trans-radial prosthetic arm is sometimes referred to as the "BE" or the prosthesis below the elbow. An artificial extremity that covers a missing arm above the elbow is a trans humeral prosthesis. The difficulty of the elbow movement leads to trans humeral amputees. A trans humeral prosthetic arm is sometimes referred to as an "AE" or below elbow prosthesis in prosthetics industry [5].

The proposed work involves the design of the prosthetic arm focusing on sketching and 3D modelling tasks using CAD software. The CT images of the amputated and non-amputated arm were taken in order to determine the dimensions of the prosthetic arm [6]. The segmentation of both arms is carried out using the thresholding technique by using Mimics software [4]. The computer-aided design of the arm and socket was developed by measuring the arm following the thresholding technique. 3D volume and surface rendering were done to establish the prosthetic movement arm [13-17].

## 2. Methodology

### 2.1. Block Diagram

The block diagram of the overall project which is illustrated in Fig. 1



**Figure 1.** Block diagram of the overall project

### 2.2. BlockDiagram Description

The CT images of the patient's amputated and non-amputated arm are obtained from the Rehabilitation. The obtained CT images of were in DICOM Format were loaded in the MIMICS software for segmentation by using the threshold method as shown in Figure 1. After segmentation, a 3D model of the arm is calculated in Mimics software. By using the dimension of the arm measured in Mimics software, the computer-aided



model of socket and arm is designed. Then for the designed arm animation were created.

### 2.3. CTImages

Computed tomography (CT) scanning of the arm is an imaging technique that uses x-rays to obtain cross-section images of the arm [3]. Medical images from CT scanners consist of grayscale material. With the advent of multidetector CT, the collection of volume has become commonplace and easy to obtain. The benefit of obtaining CT volume acquisition is that it can be reconstructed in three distinct planes: axial, sagittal, and coronal. Fig. 2 and represents the CT images of non-amputated and amputated arm.



Figure 2. CT image of non-amputated arm

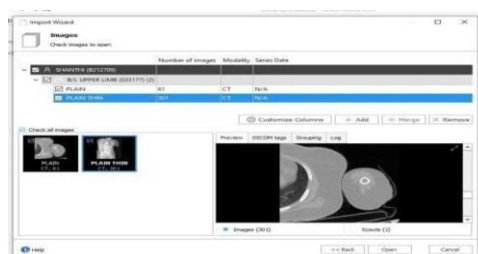


Figure 3. CT image of amputated arm

### 2.4. Mimics Software

Materialize Mimics is an image processing software used for 3D design and modeling. Mimics is an acronym for the Materialize Interactive Medical Image Control System. Materialize, Mimics is used to construct 3D surface projections from stacks of 2D image data. These 3D models used for a variety of engineering applications. Fig. 5 represents the CT images of and non-amputated arm in mimics.

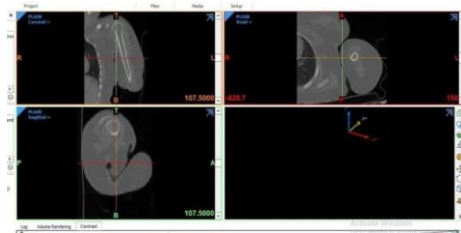


Figure 4. CT Image of Amputated Arm



Figure 5. CT Image of Non-Amputated Arm

## 3 Results

### 3.1 Segmentation Results

Patient amputation and non-amputation arm CT images were collected. The CT images have been imported into the Mimics software for segmentation process. The segmentation process covers thresholds. The following Fig. 6 and 7 shows the image of CT images after importing into the Mimics.



### 3.4 Design of socket

The socket is designed based on the amputated arm measurement. The length of amputated arm is 261.73mm and the length of non-amputated arm is 291.81mm, the missing part is 30.08mm. The socket was designed for the length of 180mm where the stump will be fixed in the socket is for 110mm. The following Fig. 11 show that the designed socket with the amputated arm.

### 3.5 Design of forearm

The forearm is designed on the basis of non-amputated arm dimensions. The non-amputated arm is 216.25 mm in length. The area measurement of non-amputated arm for length 216.25mm is given in the following Fig. 12. The design of the forearm is given in various views, the following figure 13 shows the front view of the forearm.

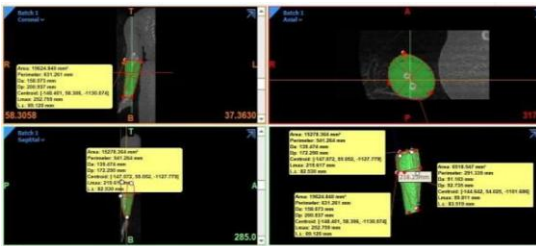


Figure 12. Area Measurement of Non-Amputated Arm at Length 261.25mm.

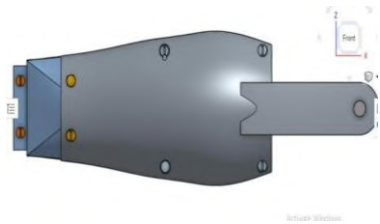


Figure 13. Front view of Forearm

### 3.6 Design off hand

The Hand is designed with the reference to the non-amputated hand. The hand consists of wrist, palm and fingers. The following Fig. 14 is given as the measurement of non-amputated hand. The following Figure 15 is given as design of palm hand (both front and back side)

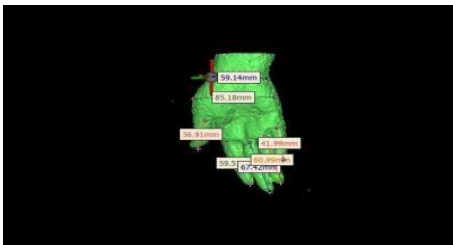


Figure 14. Measurement of Non-Amputated Hand

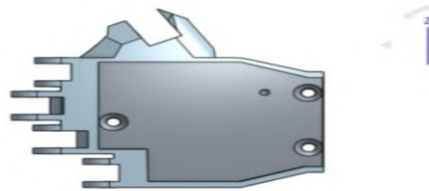


Figure 15. Design of Palm Hand

### 3.7 Design of finger

The finger consists of 4 parts they are plate, pin, upper part and lower part. The following Fig. 16 is given as design of finger. The following Fig. 17 and Fig. 18 consist of hand design and full arm design.



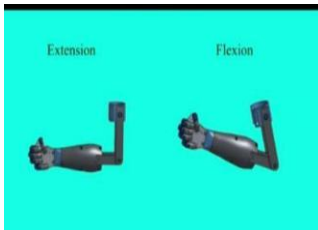
**Figure 16.** Design of Finger

**Figure 17.** Design of Hand

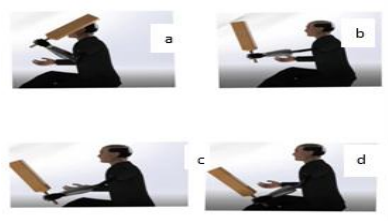
**Figure 18.** Design of Full arm

### 3.8 3D Rendering and Animation

Flexion and Extension for the designed arm is shown in Fig. 20. Based on this design, 3D surface and volume rendering are carried out as and shown in Fig. 21.



**Figure 20.** Extension and Flexion of designed arm



**Figure 21.** 3D surface and volume rendering at (a)115°(b) 90° (c) 75°(d) 45°

## 4 Conclusion and Future plan

### 4.1 Conclusion

The CT images were collected for amputated and non-amputated images. Both arms were segmented by the thresholding process in Mimics software. After segmentation in Mimics software, the 3D Arm model was developed. The area measurement of the amputated arm was performed after calculating the 3D part in Mimics software. The CAD model of socket, forearm, and hand was designed by using the dimension of the amputated arm measured from Mimics software. For the designed arm animation model was created using 3D rendering.

#### 4.2 FuturePlan

The future work would include the 3D printing of arm and FEA analysis. Further attributes such as material selection, FEA analysis of this arm will be taken for further study and the functionality of the arm were achieved by the 3Dparts. AI based VR model can be implemented for future plan.

#### References

- [1] Aditya Thakur, Rahul Rai. User Study of Hand Gestures for Gesture Based 3d Cad Modelling. International Design Engineering Technical Conferences & Computers and Information in Engineering Conference (IDETC/CIE).January 19, 2016, DETC2015-46086, V01BT02A017.
- [2] Chandra Mohan M, Purushothaman M. Design And Fabrication Of Prosthetic Human Hand Using EEG And Force Sensor With Arduino Micro Controller. Third International Conference On Science Technology Engineering And Management.2017. INSPEC Accession Number: 17507412, Volume 7 Issue No.5.
- [3] Disler Dg, Rosenthal. Accuracy of Volume Measurements of Computed Tomography and Magnetic Resonance Imaging Phantoms by Three-Dimensional Reconstruction and Preliminary Clinical Application. 01 Aug 1994, Europe PMC, PMID: 7960623.
- [4] D.S. Shin, S. Lee, H.S. Park, S.-B. Lee, M.S. Chung. Segmentation and Surface Reconstruction of a Cadaver Heart on Mimics Software. *Via Medica*, 8 May 2014, *FoliaMorphol* 2015; 74, 3: 372–377).
- [5] Dudley S. Childress. Upper-Limb Prosthetics: Control of Limb Protheses, Chapter 6D - Atlas of Limb Prosthetics: Surgical, Prosthetic, and Rehabilitation Principles, 1992, oandplibrary, Digital and Resource foundation for the orthotics and prosthetics Community.
- [6] John-John Cabibihan, M. KhaleelAbubasha .A Method For 3-D Printing Patient-Specific Prosthetic Arms with High Accuracy Shape and Size. IEEE International Conference on Rehabilitation, 2018, Volume: 6, INSPEC Accession Number: 17773708.
- [7] John-John Cabibihan, StéphanePattofatto .Towards Humanlike Social Touch for Sociable Robotics and Prosthetics: Comparisons on The Compliance. Conformance and Hysteresis of Synthetic and Human Fingertip Skins, , 2008, Springer, article s12369-008-0008-9.
- [8] MidhunVarghes. Model of Prosthetic Arm Finger Using Neural Network. IEEE International Conference on Cyborg and Bionic Systems. 2018. DOI: 10.1109/CBS.2018.8612223.
- [9] WHO Standards for Prosthetics and Orthotics. World Health Organization. Geneva. Switzerland. 2017
- [10] TeppakornSittiwanchai, Ippei Nakayama, Shi, Nichi Inoue and Jun Kobayash, Trans humeral Prosthesis Prototype With 3d Printing And SEMG-Based Elbow Joint Control Method, Proceedings of The International Conference on Advanced Mechatronic Systems, Kumamoto. 2014, DOI: 10.1109/ICAMechS.2014.6911655.
- [11] Taehyun Rhee, J.P. Lewis, Human Hand Modelling from Surface Anatomy, 2010, Researchgate publication/220792173.
- [12] J. Kate, G. Smit, and P. Breedveld, 3D-printed upper limb prostheses: A review, *Disab. Rehabil., Assistive Technol.*, vol. 12, no. 3, pp. 300–314, 2017.
- [13] Ambeth Kumar, S. Sharmila, Abhishek Kumar, A. K. Bashir, Mamoon Rashid, Sachin Kumar Gupta & Waleed S. Alnumay .A novel solution for finding postpartum haemorrhage using fuzzy neural techniques. *Neural Computing and Applications* (2021) (<https://doi.org/10.1007/s00521-020-05683-z>)
- [14] Navadeepika K.M.R., Ambeth Kumar V.D. (2021) Enhancement in Braille Systems—A Survey. *Advances in Intelligent Systems and Computing*. vol 1257. Springer, Singapore. [https://doi.org/10.1007/978-981-15-7907-3\\_10](https://doi.org/10.1007/978-981-15-7907-3_10).
- [15] V.D.Ambeth Kumar (2017).Automation of Image Categorization with Most Relevant Negatives. *Pattern Recognition and Image Analysis*, Vol. 27, No. 3, pp. 371–379, 2017- Springer
- [16] M.Ramakrishnan et.al, .Enhancement in Footprint Image using Diverse Filtering Technique. in the month of March for the *Procedia Engineering journal* (Elsevier) Journal Volume 8, No.12, 1072-1080, March 2012 and the paper was published . [doi:10.1016/j.proeng.2012.01.965]
- [17] V Rajamani, S Murugavalli . A High Speed Parrallel Fuzzy C-means algorithm for Tumor Segmentation. *ICGST International Journal on BIME* 6 (1), 2006
- [18] K. Sabarinathan et.al ., “ Machine Maintenance Using Augmented Reality”, 3rd International Conference on Communication and Electronics Systems (ICCES), 2018. (DOI: 10.1109/CESYS.2018.8723900)

- [19] B. Aravindh; V.D.Ambeth Kumar; G. Harish; V. Siddarth, “ A novel graphical authentication system for secure banking systems”, IEEE (ICSTM), Pages: 177 – 183, 2-4 Aug. 2017, DOI: 10.1109/ICSTM.2017.8089147

# I-Voting System Based on Block Chain

Dr. D. Jayashree<sup>a,1</sup>, Dr.O. Pandithurai<sup>b</sup>, S Yogeswari<sup>c</sup>, K B Swetha<sup>c</sup>, A. Shalini<sup>c</sup>  
<sup>a,b</sup>Professor, Dept of CSE, Rajalakshmi Institute of Technology, Chennai, India  
<sup>c</sup>UG Scholar, Dept of CSE, Rajalakshmi Institute of Technology, Chennai, India

**Abstract.** The Blockchain based I-Voting uses a digital-currency analogy where in eligible voters can cast a ballot anonymously using a computing environment. BIV(Blockchain I-Voting) employs an encrypted key, smart biometrics and tamper proof real-time personal ID verification. Blockchain enable the creation of tamper-proof audit trails for voting. In this generation of Technology there is an effect way for casting vote through online(Digital Voting) to make a public electoral process faster, cheaper, and more easier. In this generation it is being a compelling one in modern society which removes a power barrier between the elected candidate and the voter.

**Keyword.** Voting, BIV(Blockchain I-Voting), Digital voting.

## 1. Introduction

In our Day to day life, voting plays a major role for each and every citizen. The leader whom we choose has more responsibilities to develop a country in a more democratic way. On those days there were several voting methods to choose a leader for a country, (i.e, Paper based method, Machine voting, Postal voting, Online voting).The first voting method in every country is paper based method voting. In this voting process they will go to the polling booths and then the voter will be provided with an envelope, in that envelope they write the name of the leader or symbol of the party to whom they like to vote, and they put the envelope into the ballot they wish to vote. , "ONLINE VOTING SYSTEM" is an online voting technique. In this system people who have citizenship and above age of 18 with any sex(His/Her) are eligible for voting through online without going to any physical polling station. This voting system became more useful and advantageous than all the previous voting methods or patterns, this became more user friendly, but there were some drawbacks and issues in using this voting system, in many country's they are not ready to use this voting system because of its drawbacks. The only one country using the online voting is Estonia. Our aim of doing this project is to reduce the difficulties of voting, hereby we can vote from wherever we can access and all the country's in the world wide should use this online voting process, for this we are going to give a [1], secured process of voting system like using blockchain, hashing technology. Comparing to early days the number of voters has

---

<sup>1</sup>Dr D.Jayashree, Dept of CSE, Rajalakshmi Institute of Technology, Chennai, India.  
Email id: nambikan@yahoo.com.

been increased as the population increased, due to this we like to introduce new voting system which is based on blockchain. A blockchain based voting system is being developed to replace the current ballot box based system that requires manual effort. Digital voting systems already exist, but they are not blockchain based.

## 2. Background Study

In [1], The author proposed a new online voting system with secure authentication by using Steagnographic and biometric features. Intially the voter has to enter a password during registration. Using timestamp and hashing, here the password is converted into secret message. Once the process has over, the secret message is stored in image using steganography. Following steps are involved for vote recording and casting module, After successful authentication, a ballot is displayed, Voter cast their vote by selecting one of the candidates, This vote is encrypted and stored in database located at voter recording and casting server. Atlast the vote for the particular candidate will be generated.

In [2], The author have discussed various voting system and their advantages and disadvantages. The primary goal of this paper is to make the voting system multipurpose and make it work multiplatform on any operating system. As there is exponentially growth in the number of Smartphone users, we may say majority of the world population will own a Smartphone in future. Thereby they proposed a system which will work on any operating system be it windows, android or IOS using the QR code and OTP(one time password)functionality embedded in them. In this system the user can create their own voting ballot.

In [3], The author proposed online voting system, which addresses some of these challenges. According to voter's personal preferences, it eliminates all hardwired restrictions on the possible assignments of points to different candidates. In order to protect the confidentiality of the votes before submission, each cast ballot will be encrypted using the exponential ElGamal cryptosystem. Furthermore, during voting the system ensures that proofs are stored and generated for each element in the cast ballot during voting.

## 3. An Overview Of Blockchain And Hashing

In This Proposing Model there are four process for doing secure voting

- i. Registration for voting
- ii. Hashing Algorithm Technique
- iii. Blockchain

### 3.1. Registration for Voting

The System Administrator Registers the voters on a special site of the system. These Registration process is done and visited only by him. Citizens who are registering for vote are expected to contact the system administrator for submitting the details. After submitting the credentials, the administrator will compare with their existing database details.





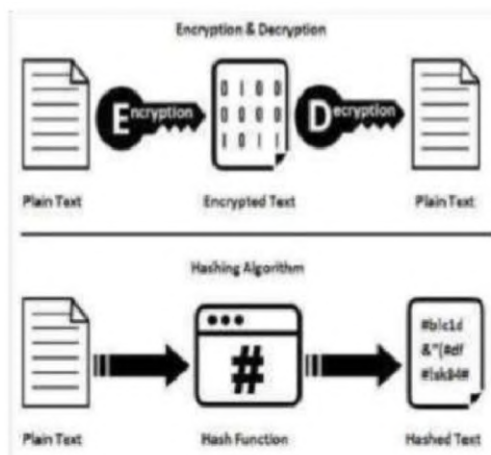
**Figure 1.** User and the Admin server

After registration the user will get a secret username and password, with that user will login and proceed the service provided like voting, checking results among others. The details are found to be invalid the voter is not allowed to register the vote.

### 3.2. Hashing Algorithm Technique

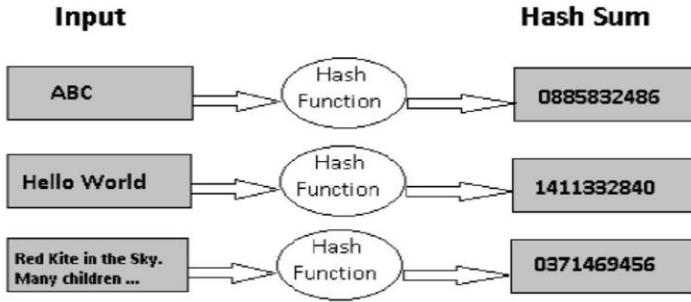
The main aim of hashing is to convert the given input of letters and numbers entered by the user into a output of fixed length in Encrypted format. A hash is build up with an algorithm and is essential to blockchain management in crypto currency (Digital Ledger for strong storing of database).

Personal health care information and medical record are stored in cloud. The above field must give more concentration to protect and give security in the cloud. Support



**Figure 2.** Hashing Algorithm

This process is referred as hashing the data. In general, When compared to the input data hash is much smaller, hence hash functions are sometimes called compression functions. Digest is a representation of larger data. In fig 2, It explains about the difference between Encryption, Decryption and the Hashing Algorithm, In encryption, while encrypting a plain text, plain text will be converted into a Encrypted text (0s and 1s) and if we want the plain text, by decrypting it we will get back the plain text. While applying hashing algorithm the input given by the user is converted into hashed text (ie. Undefined language). It is more secure and can't able to reuse by any other user, it will be accessible only for current user who registered and System Administrator.



**Figure 3.** Conversion of hash function

### 3.3 .Blockchain

Blockchain is a digital ledger. The technology draws its power from the peers or nodes – on its network to verify, process, and record all transactions across the system. This ledger is never stored, but rather exists on the “chain” supported by millions of nodes simultaneously. Thanks to encryption and decentralization, blockchain’s database of transactions is incorruptible, and each record is easily verifiable. The network cannot be taken down or influenced by a single party because it doesn’t exist in one place. This kind of system infrastructure is extremely useful for voting because a vote is a small piece of high- value data.



**Figure 4.** Secured Data

In Fig 4, Many problems discovered in these early attempts at online voting can be solved using blockchain. with the help of internet connection in the blockchain based i-voting system is highly secured, due to this hacker will not be able to affect other nodes. without revealing their identity or political preferences to the public voters can effectively submit their vote. Admin can count votes based on the user id, so that no fake votes can be created and tampering is impossible.

## 4. Conclusion

The proposed I-Voting system is based on the blockchain technology. Any registered voter will have the ability to vote using any device connected to the Internet. To make the input more secure we are using hash function and datas are locked using blockchain

technique. So, nobody able to hack the user voting details. In this paper we analyse and review the cloud security basic, threats, machine learning technique and cloud security solution through machine learning technique. Finally we conclude machine learning technique attract the academic scholar and play a important role in sensing threats and occurrences.

## References

- [1] B.Smit Khaimar, P. Sanyasi Naidu, and Reena Kharat. On Secure Authentication for Online Voting System. Department of Computer Engineering, Pimpri Chinchwad College of Engineering, Pune, India. 2016.
- [2] Dr.Z.A. Usmani, Mukesh Panigrahi, Kaif Patanwala, and Ajay Nair. On Multi-Purpose Platform Independent Online Voting System. Department of Computer Engineering, M. H. Sahoo Siddik College of Engineering, Mumbai, India, 2017.
- [3] Xuechao Yang, Xun Yi, Surya Nepal, Andrei kelarev, and Fondling On A Secure Verifiable Ranked Choice Online Voting System, 2017.
- [4] Jambhulkar S.M, Chakole B, and Pardhi R . A Secure Approach For Web based Internet Voting System Using Multiple Encryption. 2014.
- [5] Lauretha Rura, Biji Issac, and Manas Kumar Haldar . Implementation and Evaluation of Steganography Based on Online Voting System. 2016.
- [6] Himanshu Agarwal, G.N.Pandey . Online Voting System For India Based On AADHAAR ID. 2013.
- [7] Sunita Patil, Amish Bansal, Vaibhavi Pujari, Utkarsh Raina and Roushan Kumar . E-Smart Voting System with Secure Data Identification using Cryptography. 2018.
- [8] Rumeysa Bulut, Alperen Kantarci, Safa Keskin, and Serif Bahtiyar . Blockchain-Based Electronic Voting System for Elections in Turkey. 2019.
- [9] Stradiotto, C.R.K. Zotti, A.I. Bueno, and S.P.M. Hoeschl .Web 2.0 e-voting system using android platform. 2010.
- [10] R.Bhuvanapriya, S.Rozil Banu, T. Sivapriya and V.K.G. Kalaiselvi .Smart Voting .2017.
- [11] VDAK, S. Sharmila, Abhishek Kumar, A. K. Bashir, Mamoon Rashid, Sachin Kumar Gupta & Waleed S. Alnumay .A novel solution for finding postpartum haemorrhage using fuzzy neural techniques. Neural Computing and Applications (2021) (<https://doi.org/10.1007/s00521-020-05683-z>)
- [12] AnkitKumar, Vijayakumar Varadarajan, Abhishek Kumar, Pankaj Dadheech, Surendra Singh Choudhary, AKumar, B.K.Panigrahi, Kalyana C.Veluvolug . Black hole attack detection in vehicular ad-hoc network using secure AODV routing algorithm. Microprocessors and Microsystems, In Press, (<https://doi.org/10.1016/j.micpro.2020.103352>)
- [13] VDAKumar. A Cognitive Model for Adopting ITIL Framework to Improve IT Services in Indian IT Industries. Journal of Intelligent Fuzzy Systems. (DOI: 10.3233/JIFS-189131 )
- [14] V.D.Ambeth Kumar. Efficient Data Transfer in Edge Envisioned Environment using Artificial Intelligence based Edge Node Algorithm. Transactions on Emerging Telecommunications Technologies , (DOI: 10.1002/ett.4110)
- [15] V. D. Ambeth Kumar, S. Malathi, Abhishek Kumar, Prakash M and Kalyana C. Veluvolu. Active Volume Control in Smart Phones Based on User Activity and Ambient Noise. Sensors 2020, 20(15), 4117; <https://doi.org/10.3390/s20154117>
- [16] Ambeth Kumar et.al., Exploration of an innovative geometric parameter based on performance enhancement for foot print recognition. Journal of Intelligent and Fuzzy System , vol. 38, no. 2, pp. 2181-2196, 2020.
- [17] B. Aravindh; V.D.Ambeth Kumar; G. Harish; V. Siddarth, “ A novel graphical authentication system for secure banking systems”, IEEE (ICSTM), Pages: 177 – 183, 2-4 Aug. 2017, DOI: 10.1109/ICSTM.2017.8089147
- [18] K. Sabarinathan et.al ., “ Machine Maintenance Using Augmented Reality”, 3rd International Conference on Communication and Electronics Systems (ICCES), 2018. (DOI: 10.1109/CESYS.2018.8723900)
- [19] B. Aravindh; V.D.Ambeth Kumar; G. Harish; V. Siddarth, “ A novel graphical authentication system for secure banking systems”, IEEE (ICSTM), Pages: 177 – 183, 2-4 Aug. 2017, DOI: 10.1109/ICSTM.2017.8089147

- [20] V.D.Ambeth Kumar et.al., "An Efficient Security System for Data base Management from Illegal Access, IEEE International Conference on Wireless Communications, Signal Processing and Networking, 2016. DOI: 10.1109/WiSPNET.2016.7566252

# Deep Learning-Based Text Segmentation in NLP Using Fast Recurrent Neural Network with Bi-LSTM

Vinotheni.C<sup>a,1</sup> and LakshmanaPandian.S<sup>b</sup>

<sup>a,1</sup>*Research Scholar, Dept of CSE, Pondicherry Engineering College*

<sup>b</sup>*Associate Professor, Dept of CSE, Pondicherry Engineering College*

**Abstract.** Segmentation of Text, the undertaking of partitioning a record obsessed by adjoining sections dependent on its semantic design, is a longstanding test in language understanding. Each segment has its applicable significance. Those segments arranged as phrase, text group, point, express or any data unit relying upon the errand of the content examination. This paper proposes the profound learning-based content segmentation strategies in NLP where the content has been portioned utilizing quick tangled neural organization. We propose a bidirectional LSTM prototype where text group embedding is gotten the hang of utilizing fast RNNs and the phrases are fragmented dependent on context-oriented data. This prototype can consequently deal with variable measured setting data and present an enormous new dataset for text segmentation that is naturally divided. Besides, we build up a segmentation prototype dependent on this dataset and show that it sums up well to inconspicuous regular content. We find that albeit the segmentation precision of FRNN with Bi-LSTM segmentation is advanced than some other segmentation techniques. In the proposed framework, every content is resized obsessed by required size, which is straightforwardly exposed to preparation. That is, each resized text has foreordained and these phrases are taken as fragmented content for preparing the neural organization. The outcomes show that the proposed framework yields great segmentation rates which are practically identical to that of segmentation-based plans for manually written content.

**Keywords.** Text segmentation, NLP, bidirectional LSTM, fast-RNN, segmentation accuracy

## 1. Introduction

Text segmentation has been a crucial errand in natural language processing (NLP) that has tended to various degrees of granularity. In this way, segmentation phase is a fundamental advance for preparing thosedialects. At the cognizant section it is known as subject segmentation. Point segmentation is considered as a coarser level, text segmentation by and large alludes to breaking a record obsessed by a grouping of topically pre-essential to help various downstream NLP applications including text rundown and entry recovery.

---

<sup>1</sup>Vinotheni C, Research Scholar, Dept of CSE, Pondicherry Engineering College, India  
Email: vinotheni95@gmail.com

At a better level, text segmentation alludes to breaking each text group obsessed by the grouping of elementary discourse units (EDUs), regularly known as EDU segmentation [1]. The techniques regularly utilized in customary segmentation of phrases incorporate Maximum Entropy (ME) Markov Prototype, Conditional Random Field (CRF) and Hidden Markov Prototype [2].

The advancement of profound learning and phrase installing innovation types neural networks (NN) a famous decision for characteristic semantic handling significantly diminishes the outstanding burden of highlight designing, and an ever-increasing number of researchers apply NN to tackle segmentation of phrase [3]. The qualities and the construction of the information are gotten through a staggered prototype [4]. The NN has utilized in direct utilization of NN for segmentation of phrase, a Gated Recursive Neural Network (GRNN) with a versatile door and a Long Short-Term Memory Neural Networks (LSTM) usage in segmentation of phrases highlighted. In any case, a huge scope profound learning network sets aside an extended effort to track, as well as is developed by a mind-boggling prototype, which needs progress help from PC equipment [5]. The rest of the article is coordinated as the Subdivision 2 is the existing work, Area 3 as the proposed approach, test assessment and results in Section 4 and Section 5 gives future work.

## 2. Related Work

Neural organizations have been broadly utilized for NLP undertakings. The intricacy of archive segmentation rises essentially when considering records which contain text and illustrations; numerous calculations vacillate earnestly as realistic substance are misclassified as text [6]. In this manner text and realistic skewness don't represent a danger to its exhibition, where numerous different methodologies gather huge blunders during archive parsing because of skewness issues [7]. Similarly, the suggested methodology parts a report as three areas (text, reasonable, and establishment), which is a tolerably durable assignment than the division of booklets as two sections (phrase and establishment) [8]. The suggested methodology has been taken a stab at chronicles accumulated from a public database [9], and a division accuracy extent of 84% 89% is obtained for all reports; inducing that no outrageous for any of the individual records with this made division structure [10].

On the opposite side, it has appeared in numerous application spaces that profound learning approaches can give preferred outcomes over hand tailored calculations. For the content line identification issue, the lone works utilizing profound neural organizations are the various commitments of Zayene et al. [11] which propose a blend of Multi-Dimensional Long Short-Term Memory (MDLSTM) neural organization joined with convolutional levels to anticipate a jumping box around the line. In semantic segmentation, one ongoing intriguing technique is the Fully Convolutional Network [2] (FCN), whose thick levels have been eliminated, making them ready to deal with pictures from variable size [12]. The thought behind complete convolutional network functions, where the encoder compares to the CNN without thick levels, and the decoder is an extra part utilized to assemble a yield with a similar goal as the info [13]. Islam et al. [14] proposed a strategy for segmentation in records utilizing RNNs, Badjatiya et al. [15] endeavor familiar with a lucidness work utilizing the halfway requesting relations.[16-18]

### 3. Proposed Methodology

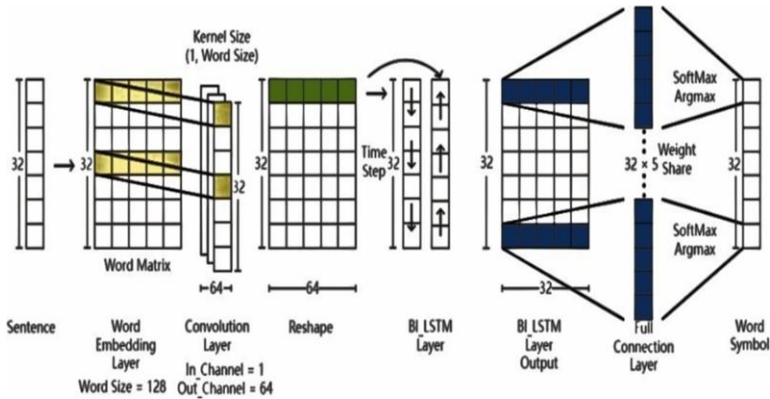


Figure 1. FRNN+ BiLSTM prototype

The underneath figure 1 shows the usage engineering of the proposed neural organization. The FRNN + BiLSTM prototype is suggested to manage division of phrase in this article. In depiction 1, from left to right: (1) Place the entire text group obsessed by the prototype and play out the Inserting taking care of. (2) The yield of the movement (1) is put obsessed by the FRNN system for phrase vector division. (3) Utilize the Bi LSTM association to get setting affiliations. The method uses a four-phase picture technique in which every character about to one of the four pictures, specifically SBME (single phrase, start phrase, focus phrase and end phrase) showing how the phrases are isolated.

#### 3.1 Labelling Method

The data collection in this article is shaped through a ton of data in different regions, for instance, books, news data, micro-blog, BBS, and thing appraisals. The method uses a four-phrase picture technique in which every character thinks about one of the four pictures, specifically SBME showing how the phrases are isolated.

#### 3.2 Embedding Level

In NLP errands, changing over content obsessed by computerized portrayal is a crucial interaction. This article uses One-Hot encrypting method as well as aides it obsessed by a low-dimensional space using the Entrenching level, which handles the issue of sparse structure and gives the limits a tremendous training space. In this level, the grid cross section  $A_n$  is  $32 \times d$ , the lattice  $A$  has everything considered 32 lines which means the text group length and the  $d$  is the segment of the phrase vector. After the Entrenching level, every text group is changed over obsessed by a grid as the commitment of the fundamental FRNN to get the novel areas.

### 3.3 FRNN Level

FRNN plans to anticipate the name of the current timestamp with the logical data of past time stamps. Each intermittent level is made by 4 RNN joined at once and to overall longitudinal development of the data. Specifically, we accept as a data an image (or else component guide of the past level)  $X$  of segments  $x \in R, H \times W \times C$ , where  $H, W$  and  $C$  are independently the height, width and number of areas (or features) and we divided it obsessed by  $I \times J$  areas  $pi, j \in R, Hp \times Wp \times C$ . We then clear vertically a first time with two FRNN  $f \downarrow$  and  $f \uparrow$ , with  $U$  intermittent units each, that drop top down and base up separately. At each step, each FRNN scrutinizes the accompanying non covering area  $pi, j$  and considering its previous state, releases an estimate  $o \star i, j$  and revives its state  $z \star i, j$  :

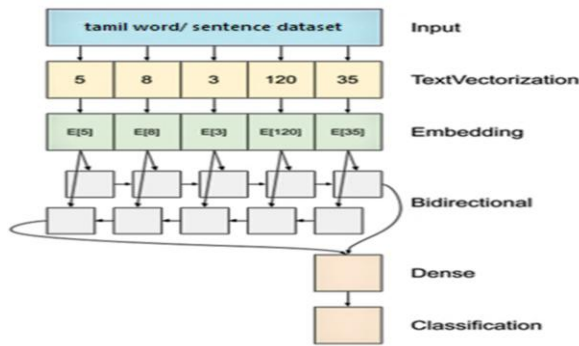


Figure 2. Proposed FRNN architecture

When two vertical FRNN have arranged the whole data  $X$ , we interface their estimates  $o \downarrow i, j$  and  $o \uparrow i, j$  to procure a composite part map  $O$  whose segments  $oli, j \in R 2U$  as the commencement of a component locator at the territory  $(I, j)$  with respect to all the areas in the  $j$ -th segment of the data. In the wake of getting the associated part map  $O$ , we clear all its lines two or three new FRNN,  $f \rightarrow$  and  $f \leftarrow$ . With a relative yet specular framework as the one depicted already, we keep scrutinizing one-part  $oli, j$  at every movement, to get a connected component map  $O \leftrightarrow = h \leftrightarrow i, jj = 1 \dots Ji = 1 \dots I$ , before long with  $o \leftrightarrow i, j \in R 2U$ . Each segment  $o \leftrightarrow i, j$  of this level redundant sublevel addresses the features of one of the data picture areas  $pi, j$  with important information.

### 3.4 BiLSTM Level

The level 3 is the BiLSTM level, as well as the novel component vector obtained from the past level data. Differentiated and the standard BiLSTM association, the phrase vector used as data. The prototype count uses the multi-dimensional segment of the phrase vector as data. The BiLSTM prototype is an enhanced LSTM prototype created by RNN prototype with a collaborative period estimation supplementary to the prototype.



## 4. Results and discussion

### 4.1 Dataset

We evaluate our method on the WIKI-727 test set, Choi synthetic dataset and the two small Wikipedia datasets. We introduce WIKI-50, a set of 50 randomly sampled test documents from WIK-I727K. We use WIK-I50 to evaluate systems that are too slow to evaluate on the entire test set.

### 4.2 Performance Analysis

The performance is based on the evaluation of other parameters such as precision, accuracy in equation 1 defined as number of correctly predicted values to total number of predictions, F1-Score in equation 2 ratios between average mean recall and precision and recall in equation 3 defined as correctly predicted value to total prediction value.

$$Accuracy = \frac{TP+TN}{TP+TN+FP+FN} \quad (1)$$

$$Recall = \frac{TP}{TP+FN} \quad (2)$$

$$F1_{Score} = 2 * \frac{Precision*Recall}{Precision+Recall} \quad (3)$$

**Table 1.** Parametric analysis for proposed technique

Data	Accuracy	Precision	Recall	F-Score
1	87.4	85.1	82.7	87.3
2	88.6	86.2	91.3	88.3
3	90.3	89.4	89.6	90.7
4	91.6	90	92.4	92.2
5	92	93.7	92.6	91.3

The performance results communicated that preparation exactness slowly increments as quantity of phrases sectioned increment. This is on the grounds that each phrase learns a prototype for the information got by it, and the quantity of phrases increment, quantity of prototypes got by every hub gets lesser and hence forth preparing the prototype for numerous ages overfit the examples and subsequently preparing for precision increments. In table 1 qualities accomplished are introduced.

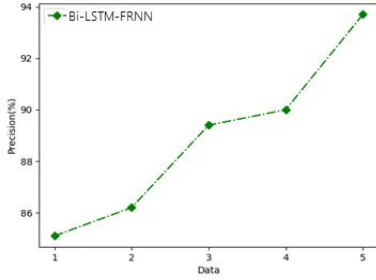


Figure 3. Precision of Research architecture

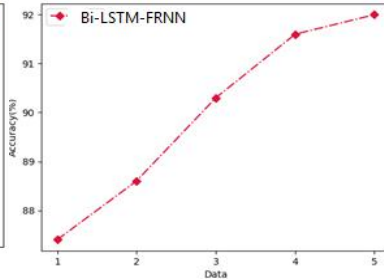


Figure 4. Accuracy of Research architecture

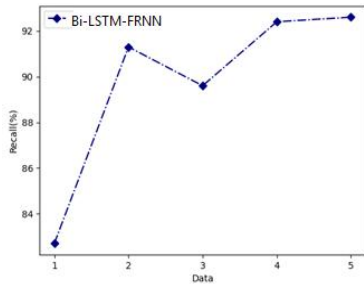


Figure 4. Recall of Research architecture

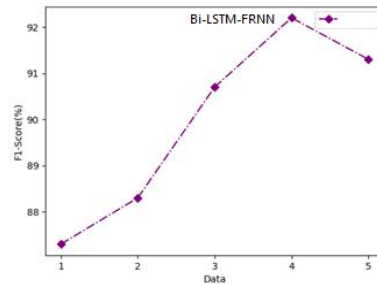


Figure 5. F-Score of Research architecture

The figure 3,4,5,6 shows the precision, accuracy, Recall and F-Score for Bi-LSTM-FRNN technique. The table 1 shows the variations of values with accuracy and precision for proposed technique. True to form, test exactness diminishes with higher number of hubs in light of the fact that every hub gets a more modest subset of preparing information and thus can't sum up the prototype. Another perception is that outfit adapting consistently gives much preferable precision over the without gathering case (best or normal).

### 5. Conclusion

The exploration works utilized BiLSTM-FRNN for sectioning the content. This paper has introduced a profound learning approach for Text segmentation. To begin with, the phrase information in an entire text group is sectioned and recombined utilizing the FRNN organization; at that point, the recombined fragment is joined in BiLSTM organization; at long last, each expression of the entire text group which is portioned gets relating segmentation of each phrase as the ensuing yield. The prototype finishes the segmentation of phrase tasks productively. The union speed and exactness are raised. It uses not just the benefits of highlight extraction of FRNN organization, yet in addition the upsides of BiLSTM network in planning. Additionally, it is demonstrated that fragmented archives of similar size as the info reports can be acknowledged by reproducing the prepared organization with tests extricated utilizing the covering examining approach.

## References

- [1] Xiong, Ying, et al. A fine-grained Chinese segmentation of phrase and part-of-speech tagging corpus for clinical text. *BMC and decision making* 19.2 (2019): 179-184.
- [2] Luo. Segment convolutional neural networks for classifying relations in clinical notes. *Journal of American Medical Informatics Association* 25.1 (2018): 93-98.
- [3] Zagoris K, Chatzichristofis, Papamarkos N. Text localization using standard deviation analysis and support vector machines. *EURASIP Adv Signal Process* 1 (2011): 1–12.
- [4] Kumar MR, Shetty NN, Pragathi BP. Text Line Segmentation of Handwritten Documents using Clustering Method based on Thresholding Approach. *International Journal of Computer Applications* (0975–8878) on National Conference on Advanced Computing - NCACC, April 2012, India, 9-12.
- [5] Vil'kin AM, Safonov IV, Egorova MA (2013). Algorithm for segmentation of documents based on texture features. *Pattern Recognit Image Anal* 23(1):153–159.
- [6] Qiu, Qinjun, et al . DGeoSegmenter: A dictionary-based Chinese phrase segmenter for the geoscience domain. *Computers & geosciences* 121 (2018): 1-11.
- [7] Li, Xiaozheng, et al. Intelligent diagnosis with Chinese electronic medical records based on convolutional neural networks. *BMC bioinformatics* 20.1 (2019): 1-12.
- [8] Yu, Chenghai, Shupe Wang, and JiajunGuo. Learning Chinese segmentation of phrase based on bidirectional GRU-CRF and CNN network prototype. *International Journal of Technology and Human Interaction (IJTHI)* 15.3 (2019): 47-62.
- [9] Liu, Junxin, et al. Neural Chinese segmentation. *Neurocomputing*(2019) 46-54.
- [10] Yao, Yushi, and Zheng Huang. Bi-directional LSTM recurrent neural network for Chinese segmentation of phrase. *International Conference on Neural Information Processing*. Springer, Cham, 2016.
- [11] Zayene, Oussama, et al. Multi-dimensional long short-term memory networks for artificial Arabic text recognition in video. *IET Computer Vision* 12.5 (2018): 710-719.
- [12] Qiu, Qinjun, et al. DGeoSegmenter: A dictionary-based Chinese phrase segmenter for the geoscience domain. *Computers & geosciences* 121 (2018): 1-11.
- [13] Shimada, Daiki, Ryunosuke Kotani, and Hitoshi Iyatomi. Document classification through imagebased character embedding and wildcard training. 2016 *IEEE International Conference on Big Data (Big Data)*. IEEE, 2016.
- [14] Islam, MdSanzidul, et al. Sequence-to-sequence Bangla text group generation with LSTM recurrent neural networks. *Procedia Computer Science* 152 (2019): 51-58.
- [15] Badjatiya, Pinkesh, et al. Attention-based neural text segmentation. *European Conference on Information Retrieval*. Springer, Cham, 2018.
- [16] R. Subha Shini et.al., “ Recurrent Neural Network based Text Summarization Techniques by Word Sequence Generation”, *IEEE International Conference on Inventive Computation Technologies (ICICT)*, 2021, DOI: 10.1109/ICICT50816.2021.9358764
- [17] K. Sabarinathan et.al ., “ Machine Maintenance Using Augmented Reality”, 3rd International Conference on Communication and Electronics Systems (ICCES), 2018. (DOI: 10.1109/CESYS.2018.8723900)
- [18] B. Aravindh; V.D.Ambeth Kumar; G. Harish; V. Siddarth, “ A novel graphical authentication system for secure banking systems”, *IEEE (ICSTM)*, Pages: 177 – 183, 2-4 Aug. 2017, DOI: 10.1109/ICSTM.2017.8089147

# Comparative Analysis Among Decision Tree vs. Naive Bayes for Prediction of Weather Prognostication

V.Sindhu<sup>a,1</sup> and M. Prakash<sup>b</sup>

<sup>a,1</sup> *Sri Shakthi Institute of Engineering and Technology, Coimbatore Tamilnadu*

<sup>b</sup> *Karpagam College of Engineering, Coimbatore, Tamilnadu*

**Abstract:** In the previous era, a computer is programmed for some specific task. An electronic device is programmed to do its function electronically. It was done with a target device, the programming environment and the system. We get the necessary intermediate code by running the program with the above said environment and committed into the target device. Thus the device performs the task it was intended to do. In case if we need to change the functionality of the device by the learning experience of the vendor and users, the vendor will upgrade the product. Nowadays in this machine learning era, the devices are programmed in such a way it can learn by its own experience and with the available data it collected it can even manipulate the algorithm by itself with the provided data set. Thus machine learning is ruling this era. We are going to discuss the machine learning algorithms here which was used to predict by itself with the data set collected. Therefore, machine learning is all about learning about computer algorithms that progress its potential through the experience. Thus, Machine learning is presently highly regarded analysis topic and applied to all told application in day to day life. In this paper we have a tendency to extract the knowledge of machine learning algorithms like decision tree, Naive Bayes and enforce the algorithms with sample dataset of weather prognostication.

**Keywords** —Machine learning, Naive Bayes, Decision tree.

## 1. Introduction

Machine learning is a programming technique that computers use to upgrade a presentation basis utilizing model information or past expertise. Machine learning will routinely acknowledge the recognized patterns in the information, and thus to utilize the revealed examples to anticipate future information or alternative outcomes of interest. Other words, Machine learning could be a category of algorithmic program that is data driven [1] (i.e) in contrast to traditional algorithmic program. the information that narrates and determines what the "smart response" is. Where as writing the software is chunk let the data do the effort instead.

---

<sup>1</sup>M. Prakash, *Sri Shakthi Institute of Engineering and Technology, Coimbatore*  
Email id:salemprakash@gmail.com

Machine learning is classified into following major types of algorithm. They are (i)Supervised (ii) Unsupervised (iii)Reinforcement

**Supervised:** It works below supervising, it is a model can foresee with the assistance of labeled dataset. Labeled dataset is data which is already famed the target answer is called Labeled dataset. It is a type of ML that uses a known training dataset to make prediction. Supervised learning is categorized two types classification and regression. **Classification:** Once the yielding variable is downright with two or more classes (yes/no; true/false; red/blue) we have a tendency to create use of categorization [2]. **Regression:** Once the yielding variable is actual or constant quantity, it is not converted to the equivalent numerical quantity [3]. **Unsupervised:** No supervision, no training given to machine learning at the side of it acts on the data, which is not labeled. It tries to spot the patterns and provides the response. "It is a type of ML algorithm used to draw inferences from dataset consisting of input data without labeled response". Unsupervised learning is categorized two types clustering and association. **Clustering:** The method of dividing the object into clusters which are comparative among them and are disparate to the object that is owned by another cluster. **Association:** It is a rule based machine. It discovers interesting relation ship between variable in large dataset [4]. **Reinforcement:** It establishes and encourage pattern of behavior. This algorithm was designed as how the brain of human respond to punishment and rewards they learn from outcomes and decide on next action. It has to make lot of small decision without human guidance [5].

## 2. Decision Tree Terminology

### 2.1 Decision Tree

It is a deliberative portrayal of all conceivable solution to a verdict dependent on explicit condition. Here, the internal nodes represent test on the attributes. For example, if u call the customer care it will redirect to Intelligent Computer Assistant and it will reply like press 1 for English and press 2 for Tamil, press 3 for Hindi and eventually it will redirect to the authorized person here the corporate using decision tree algorithm to require certain decisions [6]. The basic terminologies are given below:

**Root node:** This can be a whole population or just a few. This can be fragmented further into more consistent sets. **Leaf node:** This leaf node cannot be further grouped.

**Splitting:** It is a process where a sub node or a root node is break down into different elements on a given condition **Branch/Sub tree:** A branch is formed by splitting a tree

**Pruning:** The process of cutting the branches that is not needed or not useful.

**Child/Parent Node:** The root node is termed as parental and whatever a parent bears or arises from its nodes forms a child [7][15-21].

### 2.2. Sample Dataset

To make the comparative analysis between decision tree and "Naive Bayes" the following sample dataset is used [8].

**Table 1.** Sample weather Database

DAY	OUTLOOK	HUMIDITY	WINDY	PLAY
DAY1	SUNNY	HIGH	WEAK	NO
DAY2	SUNNY	HIGH	STRONG	NO
DAY3	OVERCAST	HIGH	WEAK	YES
DAY4	RAIN	HIGH	WEAK	YES
DAY5	RAIN	NORMAL	WEAK	YES
DAY6	RAIN	NORMAL	STRONG	NO
DAY7	OVERCAST	NORMAL	STRONG	YES
DAY8	SUNNY	HIGH	WEAK	NO
DAY9	SUNNY	NORMAL	WEAK	YES
DAY10	RAIN	NORMAL	WEAK	YES
DAY11	SUNNY	NORMAL	STRONG	YES
DAY12	OVERCAST	HIGH	STRONG	YES
DAY13	OVERCAST	NORMAL	WEAK	YES
DAY14	RAIN	HIGH	STRONG	NO

### 2.3. Building a Decision Tree

To build and decide the tree where to split in a decision tree we must have knowledge in the following terms: Gini index: The decision tree has to be built evaluating the impurity (or purity) in classification and regression tree algorithm is gini index [9].

Information Gain: The information gain is the reduction in entropy after a collection of data is part based on a characteristic developing a decision tree is tied in with discovering quality that returns the utmost information gain. Information gain can be determined by the following formula: Information Gain = Entropy(s)- [(Weighted Average) \*Entropy (each feature)]

Reduction in variance: It is an algorithm utilized for persistent objective variable. The split with lower change is chosen as the models to part the populace. Chi Square: It is an algorithm to find the quantifiable significance between the sub nodes and parental nodes.

### 2.4. Measuring the impurity

Case 1: Consider the two baskets one of its containing full of lemon and other basket is having name of the fruits as text as lemon if we select each one item randomly in basket probability of getting item will be same. So the impurity will be zero.

Case 2: Consider the two basket one of its containing lemon, apple, orange and other basket is having name of the fruits as text if we select each one item random y in basket probability of getting item will be different. So the impurity will be non-zero [10].

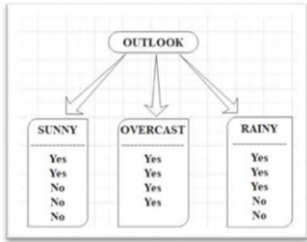
### 2.5. Entropy

It is termed used for calculating information gain. It is a metric used to measure the impurity of something. It is a very first step to solve decision tree [11]. Calculate the entropy using the following formula.

$$\text{Entropy}(s) = -P(\text{Yes})\log_2P(\text{Yes}) - P(\text{No})\log_2P(\text{No})$$

In the sample dataset out of 14 instance, we have 9 Yes and 5 No

Let us assume Outlook as root node and calculate the entropy for each



$$\begin{aligned}
 E(\text{Outlook}=\text{Sunny}) &= -2/5 \log_2 2/5 - 3/5 \log_2 3/5 \\
 &= 0.971 \\
 E(\text{Outlook}=\text{Overcast}) &= -4/4 \log_2 4/4 - 0 \log_2 0 \\
 &= 0 \\
 E(\text{Outlook}=\text{Rainy}) &= -3/5 \log_2 3/5 - 2/5 \log_2 2/5 \\
 &= 0.971
 \end{aligned}$$

Figure 1. Outlook feature

Weighted average is,

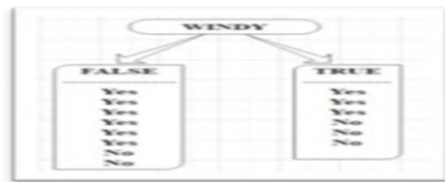


Figure 2. Windy

Let us assume Windy as root node and calculate the entropy for each feature, Similarly Calculate for the Humidity. Weighted average is  $I(\text{Humidity}) = 0.788$  and the information gained from Humidity is  $\text{Gain}(\text{Humidity}) = 0.152$

Outlook	Gain=0.247
Humidity	Gain=0.152
Windy	Gain=0.048

So the Maximum gain is Outlook (i.e.) 0.247 So Outlook is the best root node. Similarly, node to select further should be decided. Complete decision tree will be formed as given below in figure 3 and reducing complexity is shown in figure 4.

$$\begin{aligned}
 I(\text{Outlook}) &= 5/14 * 0.971 + 4/14 * 0 + 5/14 * 0.971 \\
 &= 0.693 \\
 \text{Information gained from Outlook } \text{Gain}(\text{Outlook}) &= E(s) - I(\text{Outlook}) \\
 &= 0.94 - 0.693 \\
 &= 0.247
 \end{aligned}$$

$$\begin{aligned}
 \text{Weighted average is,} \\
 I(\text{Windy}) &= 6/14 * 1 + 8/14 * 0.811 \\
 &= 0.892 \\
 \text{Information gained from Windy.} \\
 \text{Gain}(\text{Windy}) &= E(s) - I(\text{Windy}) \\
 &= 0.94 - 0.892 \\
 &= 0.04.
 \end{aligned}$$

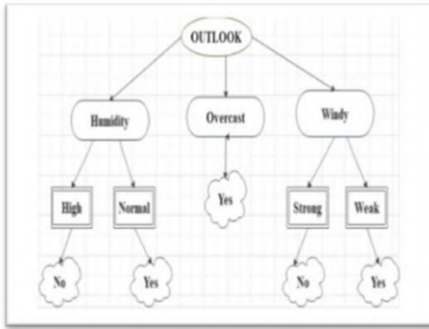


Figure 3. Pruning Tree

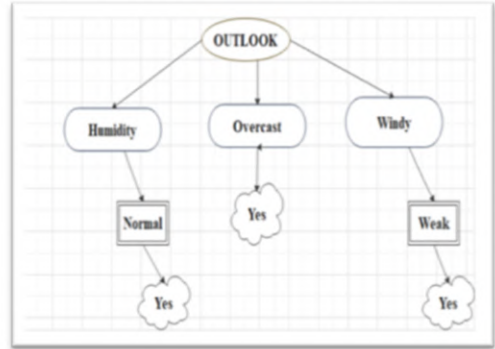


Figure 4. Reducing Complexity

### 3. What is Naive Bayes

This algorithm is quite normal but a phenomenal as for as prediction models are concerned [12]. It is one of the hierarchical classification methods of Bayes theorem. Naive and Bayes are the two categories of this algorithm [13]. An assumption like one feature which is considered here is no more a relation to another feature in this class, though that feature is dependent to other. So each feature in this class contributes with its functionality to the probability. It is used in large dataset[14].

#### 3.1 Bayes theorem

“Given a Hypothesis H and evidence E, Bayes theorem states that the relationship between the probability of the hypothesis before getting the evidence P(H) and the probability of the hypothesis after getting the evidence P(H/E) is” [14].  
 $P(H/E) = P(E/H) \cdot P(H) / P(E)$

##### 3.1.1 Classification Steps

From the above dataset the frequency table is designed for Outlook, Humidity, Windy [14]

Table 3. Frequency Table

Frequency Table		Play	
		Yes	No
OUTLOOK	Sunny	3	2
	Overcast	4	0
	Rainy	3	2
Frequency Table		Play	
		Yes	No
HUMIDITY	High	3	4
	Normal	6	1
Frequency Table		Play	
		Yes	No
WINDY	Strong	6	2
	Weak	3	3



Next, Likelihood is calculated for Outlook

**Table 4.** Likelihood for Outlook

Likelihood Table		Play		
		Yes	No	
OUTLOOK	Sunny	3/10	2/4	5/14
	Overcast	4/10	0/4	4/14
	Rainy	3/10	2/4	5/14
		10/14	4/14	

The Probability of getting  $P(\text{Yes/Sunny}) = 0.591$  and  $P(\text{No/Sunny}) = 0.40$ .  
 Similarly,  
 Likelihood for humidity is  $P(\text{Yes/High}) = 0.42$  and  $P(\text{No/High}) = 0.58$ .  
 Likelihood for Windy is  $P(\text{Yes/Weak}) = 0.75$  and  $P(\text{No/Weak}) = 0.25$ .

Suppose we have a day with following values

Outlook = Rain  
 Humidity = High  
 Windy = Weak  
 Play = ?

“Likelihood of Yes on that day

$$\begin{aligned}
 &= P(\text{Outlook} = \text{Rain/Yes}) * P(\text{Humidity} = \text{High/Yes}) * P(\text{Windy} = \\
 &\text{Weak/Yes}) * P(\text{Yes}) \\
 &= 2/9 * 3/9 * 6/9 * 9/14 \\
 &= 0.0199
 \end{aligned}$$

Likelihood of No on that day

$$\begin{aligned}
 &= P(\text{Outlook} = \text{Rain/No}) * P(\text{Humidity} = \text{High/No}) * P(\text{Windy} = \text{Weak/No}) \\
 &* P(\text{No}) \\
 &= 2/5 * 4/5 * 2/5 * 5/14 \\
 &= 0.0166
 \end{aligned}$$

So,  $P(\text{Yes}) = 0.0199 / (0.0199 + 0.0166) = 0.55$  and  $P(\text{No}) = 0.45$

Our model predicts that there will be 55 percentage chances to play the game.”

#### 4. Conclusion

This paper gave an exposure in the Machine learning algorithms like decision tree and Naive Bayes. We have used a sample weather dataset and using entropy we have calculated information gain and measure the impurity. Weighted average was calculated for the root nodes outlook, windy and humidity. The maximum gain is measured for the respective root nodes and the algorithm shuffles the value of different root nodes to discover the best root node. This technique was used to discover the maximum gain using the decision tree. The working technique of these algorithms were elaborated and discussed in this paper with the calculated values. The future work can be extended for other machine learning algorithms.

## References

- [1] Sindhu, V., Nivedha, S., &Prakash, M.(2020). An Empirical Science Research On Bioinformatics In Machine Learning.Journal of Mechanics of Continua and MathematicalSciences.
- [2] Sorower MS. A literature survey on algorithms for multi-label learning. Oregon State University, Corvallis, Dec2010.
- [3] Wang, X., Lin, X., & Dang, X. (2020). Supervised learning in spiking neural networks: A review of algorithms and evaluations. *Neural Networks*, 125,258-280.
- [4] Alloghani, M., Al-Jumeily, D., Mustafina, J., Hussain, A., &Aljaaf, A. J. (2020). A systematic review on supervised and unsupervised machine learning algorithms for data science. *Supervised and Unsupervised Learning for Data Science*,3-21.
- [5] Levine, S., Kumar, A., Tucker, G., & Fu, J. (2020). Offline reinforcement learning: Tutorial, review, and perspectives on open problems. *arXiv preprintarXiv:2005.01643*.
- [6] Wibowo, A. H., &Oesman, T. I. (2020, February). The comparative analysis on the accuracy of k-NN, Naive Bayes, and Decision Tree Algorithms in pre- dicting crimes and criminal actions in Sleman Regency. In *Journal of Phys- ics: Conference series (Vol. 1450,p.012076)*.
- [7] Wei, Y., Wang, X., & Li, M. (2020). Intelligent Medical Auxiliary Diagnosis Algorithm Based on Improved Decision Tree.Journal of Electrical and Computer Engineering, 2020.
- [8] Rajalakshmi, V., &Parasan, N. (2020). Weather Prediction Using Data Mining Approach. *Studies in Indian Place Names*, 40(71),1508-1517.
- [9] Pathak, A. R., Welling, A., Shelar, G., Vaze, S., &Sankar, S. (2020). A Framework for Performing Prediction and Classification Using Machine Learning. In *Proceedings of ICETIT 2019 (pp. 893-906)*.Springer,Cham.
- [10] Sindhu, V., &Prakash, M. (2019, November). A Survey on Task Scheduling and Resource Allocation Methods in Fog Based IoT Applications. In *International Conference on Communication and Intelligent Systems (pp. 89-97)*. Springer,Singapore.
- [11] Kelleher, J. D., Mac Namee, B., &D'arcy, A. (2020). *Fundamentals of ma- chine learning for predictive data analytics: algorithms, worked examples, and case studies*.MITpress.
- [12] Lee, I., & Shin, Y. J. (2020). Machine learning for enterprises: Applications, algorithm selection, and challenges. *IEEE Business Horizons*,63(2),157-170.
- [13] Chen, W., Zhang, S., Li, R., &Shahabi, H. (2018) . Performance evaluation of the GIS-based data mining techniques of best-first decision tree, random for- est, and naïve Bayes tree for landslide susceptibility modeling. *Science of the total environment*,644,1006-1018.
- [14] Lestari, F. P., Haekal, M., Edison, R. E., Fauzy, F. R., Khotimah, S. N., &Haryanto, F. (2020, March). Epileptic Seizure Detection in EEGs by Using Random Tree Forest, Naïve Bayes and KNN Classification. In *Journal of Physics: Conference Series (Vol. 1505, No. 1, p. 012055)*. IOPPublishing.
- [15] V. D. Ambeth Kumar, S. Sharmila, Abhishek Kumar, A. K. Bashir, Mamoon Rashid, Sachin Kumar Gupta &Waleed S. Alnumay . A novel solution for finding postpartum haemorrhage using fuzzy neural techniques. *Neural Computing and Applications (2021)* (<https://doi.org/10.1007/s00521-020-05683-z>)
- [16] AnkitKumar,VijayakumarVaradarajan,AbhishekKumar, PankajDadheech, SurendraSinghChoudhary, V.D. AmbethKumar, B.K.Panigrahi, KalyanaC.Veluvolug. Black hole attack detection in vehicular ad-hoc network using secure AODV routing algorithm.Microprocessors and Microsystems, In Press,<https://doi.org/10.1016/j.micpro.2020.103352>)
- [17] V.D.Ambeth Kumar. A Cognitive Model for Adopting ITIL Framework to Improve IT Services in Indian IT Industries. *Journal of Intelligent Fuzzy Systems*. (DOI: 10.3233/JIFS-189131 )
- [18] Ambeth Kumar.V.D .Efficient Data Transfer in Edge Envisioned Environment using Artificial Intelligence based Edge Node Algorithm. *Transactions on Emerging Telecommunications Technologies (Accepted - Inpress)*(DOI: 10.1002/ett.4110)
- [19] V. D. AmbethKumar,S. Malathi,AbhishekKumar,Prakash M and Kalyana C. Veluvolu.Active Volume Control in Smart Phones Based on User Activity and Ambient Noise.*Sensors 2020*, 20(15), 4117; <https://doi.org/10.3390/s20154117>
- [20] Ambeth Kumar.V.D and M.Ramakrishan (2013).Temple and Maternity Ward Security using FPRS”, *Journal of Electrical Engineering & Technology*, ,Vol. 8, No. 3, PP: 633-637. [<http://dx.doi.org/10.5370/JEET.2013.8.3.633>]
- [21] V.D.Ambeth Kumar and M.Ramakrishan (2013) .A Comparative Study of Fuzzy Evolutionary Techniques for Footprint Recognition and Performance Improvement using Wavelet based Fuzzy Neural Network. for the *International Journal of Computer Applications in Technology*, Vol.48, No.2,pp.95 – 105. [DOI: <http://dx.doi.org/10.1504/IJCAT.2013.056016>]
- [22] B. Aravindh; V.D.Ambeth Kumar; G. Harish; V. Siddarth, “ A novel graphical authentication system for secure banking systems”, *IEEE (ICSTM)*, Pages: 177 – 183, 2-4 Aug. 2017, DOI: 10.1109/ICSTM.2017.8089147

# A Survey on Sports Video Annotation Frameworks

N.Chidambaram<sup>a,1</sup> and G.Nallavan<sup>b</sup>

<sup>a,1</sup>Research Scholar, Department of AST & T, TNPESU, Chennai, India

<sup>b</sup>Asst. Prof., Department of AST & T, TNPESU, Chennai, India

**Abstract.** Video annotation technique delivers many additional video processing capabilities for several applications. Sports broadcast video content is unique in regard to wealth of information as compared to any other video. Sports video annotation is becoming popular among researchers in recent times because of wide range of applications and challenges it pose. The demand for optimized design of framework for sports video annotation is at peak. This paper surveys state-of-the-art in annotation framework design, particularly for sports applications and provides insight into future aspects. This survey may help researchers to further conceive and develop advanced universal frameworks applied to all sports.

**Keywords.** Sports video annotation, annotation framework design, annotation architecture, broadcasting video, Machine Learning, Neural Networks

## 1. Introduction

Several technological developments in recent past of video broadcasting and presentation have improved sports video broadcasting quality with significant increase in the number of subscribers. Apart from the conventional TV broadcasting, the boom in OTT platform, web-based (internet) telecasting, reduction in data cost and higher data rate led to a tremendous growth of sports entertainment industry in the recent times. Sports video annotation is regarded as an assisting mechanism in many sports video applications like analysis, retrieval, indexing, summarization[2], browsing/surfing, content mining, video skimming [11], providing supplementary information [10], generate metadata/metainfo for advanced techniques such as artificial intelligence and machine learning [11], video management and many more boundless areas [3,13].

The people in front of various devices watching the broadcast/telecast sports video outnumber the people watching it live on the stadium. So broadcasters have the responsibility to convince the needs of these viewers/consumers to commercially succeed and continuously entertain and retain them as long term subscribers. Annotation in sports video is crucial for broadcasters or even end-users to satisfy their commercial or personal needs respectively [1]. The upcoming sections are categorized as follows: Section 2 outlines the uses of video annotation in various sports video as a specific case.

---

<sup>1</sup> N.Chidambaram, Research Scholar, Department of Advanced Sports Training and Technology, TamilNadu Physical Education and Sports University, Melakottaiyur, Chennai, Tamil Nadu, India.  
E-mail: researchhofchidambaram@gmail.com

Section 3 analyzes various sports video annotation attributes found in literature. Section 4 deals with existing challenges and future aspects on this area. In section 5, we summarize this work and its importance in current research context.

## 2. Sports Video Annotation

Sports video annotation is still considered as hot research area among researchers due to its knowledge generating capabilities [14] and commercial value [11]. It conveys additional useful information for all kinds of videos [12]. However, the richness of content in sports video is completely different from other general videos. Furthermore, each sport video is diverse in nature, thus demanding different ways of approach in video annotation. For example, ball-only type of sport video annotation is inappropriate for racquet based sport [16].

Framework design of sports video semantic annotation is challenging, complex and very demanding [1,3]. Design of conventional or small scale framework for large scale dataset is becoming impractical [6]. The motive of video annotation and its framework is to relate the video features (low-level) and semantic labels (high-level) [3,13,14]. Moreover the framework should define semantic meaning of objects, events and context [8]. It implies scene interpretation at higher level and data acquisition. It is considered as the toughest task even for computer vision techniques [11,16].

### 2.1. Framework design/structure

The framework design falls into any one of two major categories. They are specific or generic. Specific frameworks are suitable for many sports videos and they concentrate more on sports/games related annotation tasks and generic frameworks are applied for several genres of videos with sports video as a subset. The Survey related to AVA (Automatic Video Annotation) is proposed by [13] and applicable to all general videos. The literature survey related to Sport video as specialization is carried out in this work.

#### 2.1.1. Specific Framework

Many frameworks proposed in literature are available as sports specific and some of them can be extended to general video applications. This section lists all sport-specific video annotation frameworks and briefly discusses them. Changsheng Xu et al [1] Contributed framework for video summarization and retrieval of sports video. Here, two-level annotation scheme is used. First level gives the overall summary taken from webcasting text. And second level annotates every event of video employing semantics of text as well as video boundaries grabbed from alignment of text or video.

Mentzelopoulos et al [4] has provided a system for extracting shot boundaries using low-level feature video processing algorithms. Campos et al [5] proposed an automatic sports video annotation framework based on Bayesian reasoning framework aiming to annotate court sport videos at all cognitive levels with adaptability and event classification at any time with user request.

Assfalg et al [9] contributed semantic annotation system that utilizes visual cum graphical features on the video frames. Additionally, color histogram is used for object tagging. Xue et al [10] designed an AVA system for archival sports video. This work delivers rich metainfo of the videos archived.

Kolekar et al [11] labeled video clips by automatic segmentation of broadcast videos and framework provides answers of difficult queries related to video clips. Deng et al [16] proposed data analysis annotation framework. It is dedicated to racquet sports videos and has provision for tools to carry out interactive annotation. In addition, they used supporting computer vision algorithms.

### 2.1.2. Generic Framework

The generic frameworks in literature have potential to satisfy the requirements of sports video annotation. These frameworks are considered in this survey of sports applications, because of having provision to modify them for sport needs. Zhang et al [2] proposed a semi-supervised learning framework with six types of sports events for analysis. It uses labeled, unlabeled, small scale and large scale videos to train the model. Aote and Potnurwar [3] had undergone a novel approach to define a two- level keyframe extraction method for AVA.

Hwang et.al [6] attempted to provide deep insight from enormous video datasets available in internet to train. Getahun and Birara [8] used audio element of scenes to assist identification of object and event using high level architecture. Islam et al [14] highlighted the importance of distributed framework for AVA. The concept is spatio and spatio-temporal oriented that provides application based solution for users. Human action in sports is taken for their analysis. Huskey and Hill [15] facilitated dedicated video pane in video annotation interface with many functionalities.

## 3. Literature Survey

Various attributes of sports video annotation framework are listed in Table 1 with both specific and generic framework taken into consideration.

**Table 1.** Attributes of Sports Video Annotation Framework

Reference	Framework Type	Approach	Applications	Sports Use Cases	User/Personal Preference
[1]	Specific	Web Casting Text	Semantic annotation Indexing & Retrieval	Soccer, Basket ball and other sports/ games	Summary Creation
[2]	Generic	Semi-supervised Learning	Training for event detection and annotation	Basket ball	Search and browse Videos

[3]	Generic	Machine Learning	Shot detection, keyframe and feature extraction	Generally sports	None
[4]	Specific	Active region detection & extraction	Automatic Video segmentation for annotation	Football, Squash & Basketball	None
[5]	Specific	Anomaly Detection & Transfer Learning	Annotate court sports video	Tennis	Event Classification
[6]	Generic	Mapreduce training	annotation for large datasets	Basket ball (As framework input)	None
[7]	Generic	Convolutional Neural Network	Analysis and Management	General	None
[8]	Generic	Video Scenes & associated audio	Event and Object Identification	Basket ball (Shot & Scene Identification)	Video addition, threshold setting, result visualizing and XML or SRT file generation for annotation
[9]	Specific	Visual & graphical features using neural networks	annotate videos at different layers of semantic significance	Several sport videos & Studio/Interview shots	Retrieval of specific shots on demand
[10]	Specific	Computer Vision	archival sports video	Baseball	None
[11]	Specific	Event & Concept level	Semantic labeling	Soccer	Answers difficult queries
[14]	Generic	Spatial & Spatio-temporal	1.End-user distributed VA services 2.Developer algorithm services	Baseball (Pitch), Skate boarding & running	create new VA algorithms through VA & APIs
[16]	Specific	Data Analysis with CV Techniques	Multiple level video data annotations	Racquet sports	User event acquiring from videos & offers interactive tools

---

#### 4. Future aspects

With the advent of advanced learning methods such as machine learning, computer vision and neural networks [3,7,16], the annotation task becomes easier. But, the existing data acquisition abilities suffer from limitations [16] and faces challenges [3]. The need for universal annotation framework for all sports is essential. Preference must be given to scalability, adaptability and applicability features of a framework.

#### 5. Conclusion

This paper summarizes domain-specific and generic frameworks with application to sports video. The characteristics/attributes of frameworks related to sports video annotation are presented. Investigators, particularly in field of sports video annotation may find this work useful for their optimized framework design.

#### References

- [1] Changsheng Xu, Jinjun Wang, Hanqing Lu, and Yifan Zhang, A Novel Framework for Semantic Annotation and Personalized Retrieval of Sports Video, *IEEE Trans. Multimedia*. (2008) 421–436.
- [2] T. Zhang, C. Xu, G. Zhu, S. Liu, and H. Lu, A Generic Framework for Video Annotation via Semi-Supervised Learning, *IEEE Trans. Multimedia*. (2012) 1206–1219.
- [3] S.S. Aote, and A. Potnurwar, An automatic video annotation framework based on two level keyframe extraction mechanism, *Multimedia Tools Appl.* (2019) 14465–14484.
- [4] M. Mentzelopoulos, A. Psarrou, A. Angelopoulou, and J. Garcia-Rodriguez, Active Foreground Region Extraction and Tracking for Sports Video Annotation, *Neural Process Lett.* (2013) 33–46.
- [5] T. de Campos, A. Khan, F. Yan, N. Davar, D. Windridge, J. Kittler, and W. Christmas, A framework for automatic sports video annotation with anomaly detection and transfer learning, ACASVA, 2012.
- [6] S.J. Hwang, J. Lee, B. Varadarajan, A. Gordon, Z. Xu, and A. (Paul) Natsev, Large-Scale Training Framework for Video Annotation, in: Proceedings of the 25th ACM SIGKDD International Conference on Knowledge Discovery & Data Mining, ACM, Anchorage AK USA, 2019: pp. 2394–2402.
- [7] W. Tong, L. Song, X. Yang, H. Qu, and R. Xie, CNN-based shot boundary detection and video annotation, in: 2015 IEEE International Symposium on Broadband Multimedia Systems and Broadcasting, IEEE, Ghent, Belgium, 2015: pp. 1–5.
- [8] F. Getahun, and M. Birara, Towards a Scene-Based Video Annotation Framework, in: 2015 11th International Conference on Signal-Image Technology & Internet-Based Systems (SITIS), IEEE, Bangkok, Thailand, 2015: pp. 306–313.
- [9] J. Assfalg, M. Bertini, C. Colombo, and A.D. Bimbo, Semantic annotation of sports videos, *IEEE Multimedia*. (2002) 52–60.
- [10] Y. Xue, Y. Song, C. Li, A.-T. Chiang, and X. Ning, Automatic Video Annotation System for Archival Sports Video, in: 2017 IEEE Winter Applications of Computer Vision Workshops (WACVW), IEEE, Santa Rosa, CA, USA, 2017: pp. 23–28.
- [11] M.H. Kolekar, K. Palaniappan, and S. Sengupta, A novel framework for semantic annotation of soccer sports video sequences, in: IET 5th European Conference on Visual Media Production (CVMP 2008), IEE, London, UK, 2008: pp. 8–8.
- [12] V. Mittal, Annotation Framework for Video, Google LLC, Mountain View, CA (US Patent), 2020.
- [13] K. Randive, and R. Mohan, A State-of-Art Review on Automatic Video Annotation Techniques, in: A. Abraham, A.K. Cherukuri, P. Melin, and N. Gandhi (Eds.), Intelligent Systems Design and Applications, Springer International Publishing, Cham, 2020: pp. 1060–1069.
- [14] M.A. Islam, M.A. Uddin, and Y.-K. Lee, A Distributed Automatic Video Annotation Platform, *Applied Sciences*. (2020) 5319.
- [15] S. Huskey, and R. Hill, Multi-Modal Collaborative Web-based Video Annotation System, University of North Carolina, (US Patent), 2018.
- [16] D. Deng, J. Wu, J. Wang, Y. Wu, X. Xie, Z. Zhou, H. Zhang, X. Zhang, and Y. Wu, Event Anchor: Reducing Human Interactions in Event Annotation of Racket Sports Videos, 2021.

# Decentralized Loan Management Application Using Smart Contracts on Block Chain

Arikumar K S<sup>a,1</sup>, Deepak Kumar A<sup>b</sup>, Gowtham C<sup>b</sup>, SahayaBaniPrathiba<sup>c</sup>

<sup>a,1,b</sup>St.Joseph's Institute of Technology, Chennai, India

<sup>c</sup>MIT Campus, Anna University, Chennai, India

**Abstract.** The most shocking events were was the recent discovery of the fraudulent activities in the Punjab National Bank. This is due to frequent systemic failures that detect human errors. Blockchain technology is the greatest solution for this issue. It is surprisingly common for the information settlement mechanism like SWIFT to be on a isolated ledger from the payment settlement mechanism. If the banks uses a ledger that stores information settlement distributed across all the participants, then the fraudulent user may reflect on all the available participants in the transactions, auditors and regulators. Our Paper is a Decentralised Loan Management Web Application (DApp) built on Ethereum blockchain which targets on preventing such fraudulent attacks on Loans sanctions by decentralising the processes. The security features authentication of the user identity, authentication of bank officials and multiple levels of verification of details are implemented using Public Key Infrastructure (PKI).

**Keywords:** BlockChain, Loan Management System, User Privacy, Smart Contracts.

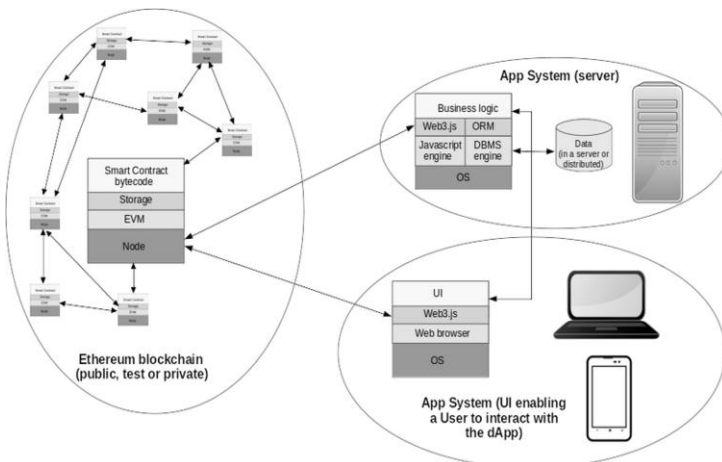
## 1. Introduction

Banking security and privacy remains a major challenge. This brings in the new technology in the field of financial services industry in the form of blockchainbanking[1]. From greater user privacy and heightened security to lower processing fees and fewer errors, blockchain technology can make tremendous change in banking sector[2]. In this paper, the various core components and functions of the smart contract are outlined and analyzed. The proposed BC-based loan management is secure by thoroughly analyzing its security with respect to the fundamental security goals of confidentiality, integrity, and availability. The proposed system aims on preventing fraudulent attacks like PNB scam on Loans sanctions by decentralising the processes involved in Loan Sanctioning by using smart contracts and Ethereum Blockchain. Ethereum is an open-source, blockchain-based, platform which gives way for developing various Distributed Applications (DApps)for creating Smart Contracts. This platform provides advantages such as controlling frauds, system downtimes, interferences and the third-party frauds. Proof of authority and proof of work algorithms ensures that the data is real, authorized and immutable.

---

<sup>1</sup>Arikumar K S, St.Joseph's Institute of Technology, Chennai, India.  
E-mail: ksarikumar@gmail.com

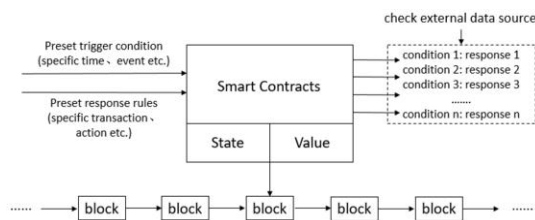




**Figure.1.** Architecture diagram for the proposed dApp system

## 2. Related Works

In this section, Hao Wang, Chaonian Guobet. al., designed a loan management system called LoC, which attempts to manage the loans based on smart contracts over permissioned blockchain Hyperledger Fabric [3]. Konstantinos Christidis et. al., designed Blockchains and Smart Contracts for the Internet of Things [4], which allows to have a distributed verifiable peer-to-peer network with non-trusting members can interact with each other without a trusted intermediary [5]. Gareth W. Peterst et. al., designed an Internet of Money [6] and Hiroki Watanabe et. al., designed Block-chain Contract for securing a blockchain. This prevents the attacker for being controlling the resources, which in turn secures the blockchain [7].



**Figure.2.** Mechanism of Smart Contract

## 3. System Architecture

Fig.1 depicts the flow of data and control among various operations of a Ethereum Decentralized Application. It also holds modules for authorization of nodes and verification and validation of resources concerned. Fig.2 depicts the working of the

smart contracts for block creation and adding created blocks to the blockchain. Smart contracts help in exchanging valuables, shares, properties, and money without any conflicts. Furthermore, the system eliminates the intermediary called broker fares. The concept behind the smart contract can be easily described with the technology description of vending machine. The Smart Contracts in DApps enforces obligations in addition to defining rules and charging penalties for the created agreement.

### *3.1 DApp System*

We have followed the approach of developing, implementing and testing the DApp in the ethereum simulator Ganache[8]. Primarily, we launch the Ganache Ethereum Simulator using `ganache-cli` command in the command prompt. The simulator then creates 10 accounts which resemble the nodes in the blockchain. As the next step, connect to the Remix IDE by selecting the option Web3. Provider localhost:8545. Then start the Apache HTTP server and MySQL using XAMPP and handle the administration using phpMyAdmin.

### *3.2 Loan Requesting and Sanctioning Process*

The first UI of our DApp is the sign up / login page. Once the user logs in, the welcome page appears. Then he/she has to sign a message using their private key and this signature is then stored in the bank database. If login not available, the user creates an account in the Banking website by entering his/her Public Key along with the basic information for KYC. Then, the Loanee / Representative of an organisation has to digitally sign a fixed message (previously set by the bank and updated periodically) using his/her Private key before applying for loan or Loan.

If the verification is a success, then, the bank officials digitally sign the details of loan using their private key and upload the signed details in the blockchain. In case of loan, the block hash is stored in the user database. When the required number of bank officials authorize a particular loan (i.e) more block hashes are stored for a particular loan, the loan is sanctioned. Hence, multiple authentications and verifications are done before sanctioning loans thus augmenting more security by decentralizing the loan process [11-15].

### *3.3 Loan Sanction Algorithm*

The Algorithm 1 is based on the loan sanction algorithm which is used at the backend of the loan management application to secure and ensure data integrity in the loan sanction process. The first parameter used in this algorithm is the `user_type` which has the type of the user. `Sign method`, `verify method` are used to verify the signature with the public key using digital signature algorithm. `add_block` creates a new block and stores the information passed to it in the block and adds the block to the block chain. `Save method` stores the parameter passed to it to the database.

**Algorithm 1**


---

```

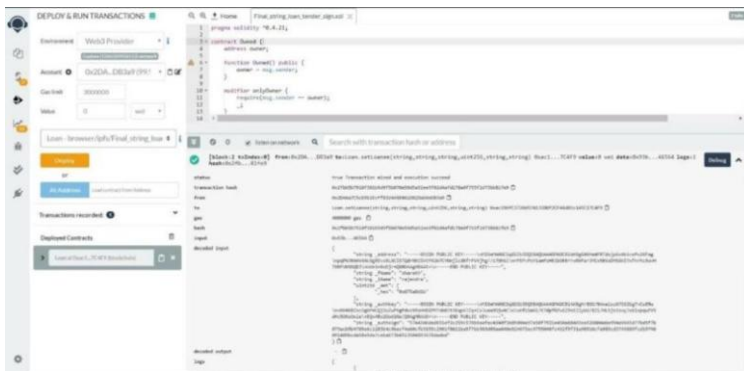
Input: Loan_msg, Key of Loanee
Output: Blockhash
if user_type equals loanee then
    sign(loan_msg, loanee.privateKey)
else
    if user_type equals admin then
        if verify(sign, loanee.publicKey) is valid then
            sanction(loanee_details, loan_details)
            sign(loan_details, admin.privateKey)
            add_block(loan_details)
            save(blockhash)
        else if not valid halt
    endif
endif
endif

```

---

**3. Results and Discussions**

In this section, we present the simulation of our proposed system. The Backend code for the Banking Smart Contract is written in the language Solidity. The Solidity code written using the Solidity version 0.4.21[10].



**Figure.3.** Storing Loan details in Blockchain and storing Blockhash in database

The Fig.3 shows remix IDE, which shows the details of the added block of the blockchain. Remix is a browser-based compiler and IDE that enables users to build Ethereum contracts with Solidity language and to debug transactions.

#### 4. Conclusion

In this paper, we proposed a loan management system based on blockchain namely DApp. In real-time, the system securely shares the details about transactions by organizing the network, this action prevents the frauds in the system. Our proposed system maintains the privacy of the valuable customers by eliminating the attackers or frauds who injecting vulnerable data. By our proposed system, the banks in India can be completely digitalized without any hesitation from the hackers and the attackers. Thus, the integration of blockchain in the loan management system incorporates easier, faster, and cheaper solutions, which can be adapted by the existing banking systems for experiencing the high-level security and privacy.

#### References

- [1] Sachchidanand Singh and Nirmala Singh, Blockchain: Future of Financial and Cyber Security. 12,2017.
- [2] Adam Hahn and Rajveer Singh. Smart contract-based campus demonstration of decentralized transactive energy auctions.17(1), 2018.
- [3] Hao Wang, ChaonianGuob and Shuhan Cheng . LoC — A new financial loan management system based on smart contracts
- [4] Arikumar K.S., Natarajan V. (2021) FIoT: A QoS-Aware Fog-IoT Framework to Minimize Latency in IoT Applications via Fog Offloading. In: Bhateja V., Peng SL., Satapathy S.C., Zhang YD. (eds) Evolution in Computational Intelligence. Advances in Intelligent Systems and Computing, vol 1176.Springer, Singapore. [https://doi.org/10.1007/978-981-15-5788-0\\_53](https://doi.org/10.1007/978-981-15-5788-0_53)
- [5] Gareth W.Peterst and EfstathiosPanayi. Future of Transaction Processing and Smart Contracts on the Internet of Money. November 19, 2015.
- [6] Hiroki Watanabe and Jay Kishigami . Blockchain Contract: Securing a block chain applied to Smart contracts. 20,2018.
- [7] M. Ali, J. Nelson, R. Shea, and M. J. Freedman. (Feb. 2016).Block stack: Design and Implementation of a Global Naming SystemWith BC.
- [8] Jiin– Chiou Cheng and Narn – Yih Lee. Blockchain and Smart Contract for Digital certificate. 21,2017.
- [9] Maxim Ya.Afanasev and Yuri V. Fedosov.An application of block chain and smart contracts for machine-to-machine communication. May21,2017.
- [10] Yi-HuiChenandShih-Hsinchen, Blockchainbasedsmartcontractforbiddingsystem, October 30,2016.
- [11] S.Hema Kumar, J.UdayKiran, V.D.AKumar, G.Saranya, Ramalakshmi V.Effective Online Medical Appointment System. International Journal of Scientific & Technology Research, Volume 8, Issue 09, September 2019, Pages 803 – 805.
- [12] V.D.Ambeth Kumar, Dr.M.Ramakrishnan, V.D.Ashok Kumar and Dr.S.Malathi (2015).Performance Improvement using an Automation System for Recognition of Multiple Parametric Features based on Human Footprint. for the International Journal of kuwait journal of science & engineering, Vol 42, No 1 (2015), pp:109-132.
- [13] V.D.AKumar, V.D.Ashok Kumar, S.Malathi, K.Vengatesan, M.Ramakrishnan.Facial Recognition System For Suspect Identification Using A Surveillance Camera. Pattern Recognition and Image Analysis (Springer), Volume 28, Issue 3, pp 410–420, 2018. (DOI: 10.1134/S1054661818030136)
- [14] V.D.Ambeth Kumar and M.Ramakrishan.Employment Of Footprint Recognition System. in the month of December for Indian Journal of Computer Science and Engineering (IJCSE) Vol. 3 No.6 Dec 2013
- [15]Ramyra,T.,Dr.Malathi,S.,ratheeksha,G.R. and Dr.V.D.Ambeth Kumar (2014). Personalized authentication procedure for restricted web service access in mobile phones. Applications of Digital Information and Web Technologies (ICADIWT), 2014, Page(s):69 - 74, Bangalore, India (ISBN:978-1-4799-2258-1)
- [16] B. Aravindh; V.D.Ambeth Kumar; G. Harish; V. Siddarth, “ A novel graphical authentication system for secure banking systems”, IEEE (ICSTM), Pages: 177 – 183, 2-4 Aug. 2017, DOI: 10.1109/ICSTM.2017.8089147

# Feasibility of Infrared Thermography for Health Monitoring of Archeological Structures

N.M. Nandhitha<sup>a,1</sup>, S. Emalda Roslin<sup>b</sup>, Rekha Chakravarthi<sup>b</sup>, M.S. Sangeetha<sup>b</sup>  
<sup>a,1,b</sup>Faculty, School of Electrical and Electronics, Sathyabama Institute of Science and Technology, Old Mamallapuram Road, Chennai – 600 119

**Abstract.** Archeological assets of the nation are to be preserved and rejuvenated. Ageing of these sites poses a major challenge in assessing the health of these structures. Hence it necessitates a technique that is non contact non invasive and non hazardous. Passive InfraRed Thermography is one such technique that uses an IR camera to capture the temperature variations. Thermal variations are mapped as thermographs. Interpretation of thermographs provides information about the health of the archeological structures. As the paradigm has shifted to computer aided interpretation, segmentation techniques and line profiling are used for describing the hotspot. Of the various segmentation techniques, morphological image processing provides accurate segmentation of cold spot.

**Keywords:** Health Monitoring, Infrared Thermography, Line Profiling, Thresholding, Morphological Image Processing.

## 1. Introduction

India is a country noted for its rich cultural heritage and every historical place is a treasure of arts and architecture, a gateway to understand the rich life style and glory of ancient kingdoms. Emperors and kings of India built temples and forts to signify their achievements and as a means of supporting spiritualism. Examples are many: Emperor Asoka built stupas all over the country to mark the important events of Gautama Buddha. In the south, Krishnadeva Raya was a great patron of arts and architecture. Likewise, Raja Raja Chola I built Bragadheeswara temple at Tanjore, Rajendra Chola I built Gangaikonda Chola puram, Pallava kings built Akamberaswarar temple at kancheepuram, rock temples at Mamallapuram to mark their victories and to spread the religion of interest.

Madambakkam in Chennai, Tamil Nadu hosts Shri Dhenupureeswarar temple built by Paranthaka Chola, the father of great Raja Raja Chola. All the pillars and walls are adorned with intricately designed sculptures to depict the happenings in Chola regime. Due to these facts, Archeological Society of India has included the

---

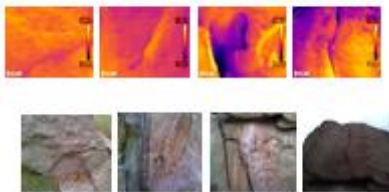
<sup>1</sup>N.M. Nandhitha, <sup>a</sup>Faculty, School of Electrical and Electronics, Sathyabama Institute of Science and Technology, Old Mamallapuram Road, Chennai  
E-mail: roemi\_mich@yahoo.co.in

temple in its database. However as years progress; it is necessary for monitoring the health of temple building. Major challenge lies in identifying an appropriate modality for acquiring images without disturbing the structures. InfraRed Thermography is one such Non-Destructive Technique is a non-contact, non-invasive and non-hazardous technique. It uses an IR camera that captures heat patterns and maps it into thermographs. These thermographs are then interpreted to determine the presence of anomalies like crack, chemical disintegration and moisture in the walls.

Brooke (2018) examined various buildings and monuments for extracting the hidden historic information present in the structures. A passive infrared thermal camera was used to identify the irregularity on the structures and to identify the materials used in the structures. The authors also claimed passive thermal infrared imaging as the best tool for evaluating the archeological structures [1]. Adamopoulos et al (2020), used thermal camera and a RGB camera for modeling of 3 D thermograph for evaluating architectural heritage assets. The accuracy of the proposed model rely on the RGB images acquired by the high resolution camera and not on the IRT images RGB images acquired by the high resolution camera and not on the IRT images [2]. Jia-Hao He et al (2020), proposed a IRT measurement system for Structural health monitoring and compared the results obtained with that using accelerometers. They also proposed Mode Shape Recombination Method (MSRM) to perceive various large-scale structural measurements. The proposed MSRM was suitable for examining the structures in any harsh environment [3]. Image Processing algorithms along with the acquired thermographs enable us to accurately predict the hidden information in the structures, condition monitoring of electrical equipment's etc. [4][5][6]. In this paper, feasibility of image processing techniques for the segmentation of anomalies in thermographs is studied. Section 2 deals with research database. In section 3, interpretation of thermographs using line profiling is dealt. Thresholding techniques used for the segmentation of anomalies from hotspots are described in section 4. Section 5 concludes the work and provides the future directions.

## 2. Research Database

Thermographs are acquired using FLIR T335 IR camera. Defects namely crack, decay due to salt formation, and rising dampness are considered in this work. Thermographs and visible images depicting the above three conditions are shown in Figures 1-3. Thermal images are acquired from Dhenupureeswarar temple, Tiger caves and Mamallapuram rock temple.



**Figure.1.** Thermographs and visible images depicting crack

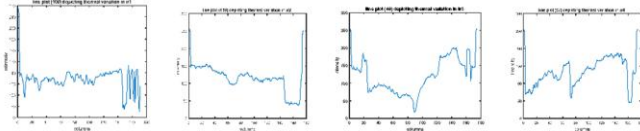


**Figure.2.** Thermographs and visible images depicting chemical integration

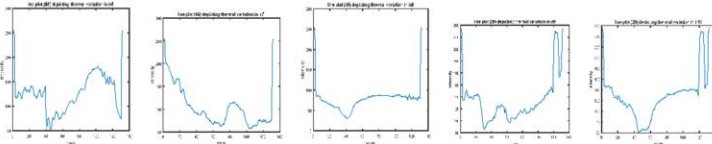
Cracks can be seen in both visible and IR images (Figure 1). However temperature gradient cannot be obtained from visible images. Temperature gradient is an important measure in health monitoring of sculptures as it can be related to rate of deterioration. Chemical disintegration also leads to thermal variations as is seen in Figure 2. However moisture is not seen in visible images but is evident in thermal images. Also the position of moisture, shape of the affected region and thermal gradient can be obtained from thermal images [8].

### 3. Anomaly Detection from the Line Profiles

Whenever there is an abrupt variation in temperature then it indicates an anomaly. It is possible to detect the size of the anomaly through line profiling. Also it is possible to detect the seriousness of the anomaly from the thermal gradient. For cracks, the line profiling must be done along the row and for anomalies in a wall; the line profiling must be done along the column. The corresponding line profiles are shown in Figures 4 and 5.



**Figure 3.** Line plots depicting the intensity along the columns of a particular row for thermographs IR 1-4 depicting crack

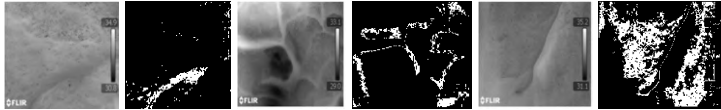


**Figure 4.** Line plots depicting the intensity along the rows of a particular column for thermographs IRs 5, 6-10 depicting defects along the wall

In the above thermographs (Figure 4) at the regions of crack, the intensity decreases when compared to the neighboring regions. In all the above line profiles, it is found that, there is a dip in the intensity curve and the slope of the curve depicts the temperature gradient and the duration of the dip determines the length of the crack. On the other hand, in case of health monitoring of walls, it is necessary to understand the line profile of a particular column along the rows. Intensity variation (dip) can be easily identified and the slope and duration of the dip indicates temperature gradient and the length of the affected region. In both the cases, the slope of thermal gradient and the duration of the anomaly can be identified only for the particular row or column. It is difficult to identify all the rows/columns and to consolidate the slope and the gradient. Hence it is necessary to segment the anomaly and hence the complete information about the anomaly can be obtained.

#### 4. Segmentation Techniques for Hotspot Isolation in Thermographs

Segmentation is a subjective process that is used for identifying the Region of Interest. Of the various segmentation techniques, thresholding is the simplest method used for the isolation of cold spots from thermographs. In this technique, thresholds are fixed to reflect the Region of Interest and all the pixels with the threshold region are retained. After subjective analysis of thermographs, threshold used for extracting the low temperature region is from 110 to 120. The gray scale thermograph, output thermographs extracted from the original thermographs are shown in Figure 5.



**Figure 5.** Gray Scale and hotspot isolated thermographs for three sets of thermographs

From the subjective analysis, it is found that global thresholding, does not provide the desired results for the second and third set of thermographs. Hence local thresholding is needed for extracting the desired hotspots. The minimum, maximum and hotspot temperature in degree centigrade are shown in Table 1. The hotspot temperature is obtained using the formula proposed by using Equation 1 Bilodeau (2011).



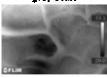







**Table 1.** Average intensity, minimum, maximum and cold spot temperature in degree centigrade (single threshold)

Average intensity	Minimum temperature in degree centigrade	Maximum temperature in degree centigrade	Cold spot temperature in degree centigrade
7.128156	30.8	34.9	30.91461
28.99658	31.1	35.2	31.56622
8.81671	29.4	33.4	29.5383
9.220087	27.9	31.9	28.04463
8.891818	25.4	29.9	25.55691
19.43978	25.7	29.8	26.01256
11.21693	29	33.1	29.18035
5.037792	29.7	53.3	30.16624
18.66143	29.4	33.4	29.69273
9.280346	30.3	34.3	30.44557

As the cold spot cannot be identified to its full extent and undesirable regions are also found, accuracy of cold spot temperature prediction must be increased. In order to increase the accuracy, it is necessary to identify the threshold for individual thermographs or group of thermographs. Threshold, gray scale thermographs and cold spot isolated thermographs are shown in Table 2.



**Table 2.** Image based thresholding for segmentation of cold spots from thermal images

Thermo-graphs	Intensity	Gray scale thermograph	Cold spot isolated thermograph
ir_6	65<=threshold<=100		
ir_7	65<=threshold<=74		
ir_8	35<=threshold<=51		
ir_9	60<=threshold<=97		
ir_10	60<=threshold<=97		







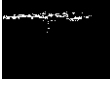
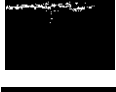


From the last column of the Table 2, it is found that undesirable regions are present. However the cold spots are identified to the best extent when compared to the previous thermographs. It is visible in Table 3 from the better prediction of cold spot temperature when compared to the previous technique. However undesirable regions are also present and hence the cold spot temperature must be obtained more accurately.

**Table 3.** Average intensity, minimum, maximum and cold spot temperature in degree centigrade (image dependent threshold)

Average intensity	Minimum temperature in degree centigrade	Maximum temperature in degree centigrade	Cold spot temperature in degree centigrade
10.2259	30.8	34.9	30.9644
9.0579	31.1	35.2	31.2456
0.7900	29.4	33.4	29.4123
11.2329	27.9	31.9	28.0762
14.1463	25.4	29.9	25.6496
15.7641	25.7	29.8	25.9534
3.0385	29	33.1	29.0488
3.2823	29.7	53.3	30.0037
5.8306	29.4	33.4	29.4914
7.9052	30.3	34.3	30.4240

In order to remove the undesirable regions, morphological image processing algorithm can be used. Image dependent threshold is chosen for thermograph and erosion is performed to remove the undesirable region. The size and shape of the structuring element is also dependent on the thermograph. The threshold, structuring element, its shape and size, segmented image and output image after erosion are shown in Table 4.

**Table 4.** Morphological Image Processing for the accurate segmentation of cold spots from thermal images

Image	Threshold	Structuring element/size	Segmented image	Output image after erosion
ir_6	65<=threshold<=100	Line/1/90degrees		
ir_7	65<=threshold<=74	Line/1/90degrees		
ir_8	35<=threshold<=51	NA		
ir_9	60<=threshold<=97	NA		
ir_10	60<=threshold<=97	NA		

Undesirable regions are removed completely as is evident from the last column of the Table 4. The cold spot temperature is identified and is shown in Table 5. The obtained cold spot temperature is accurate and hence is better than the previous two techniques. The average intensity, maximum, minimum and cold spot temperature.

**Table 5.** Average intensity, minimum, maximum and cold spot temperature in degree centigrade (Morphological image processing)

Average intensity	Minimum temperature in degree centigrade	Maximum temperature in degree centigrade	Cold spot temperature in degree centigrade
3.4396	30.8	34.9	30.8553
1.0491	31.1	35.2	31.1168
0.1139	29.4	33.4	29.4017
1.2782	27.9	31.9	27.9200
11.1670	25.4	29.9	25.5970
13.4173	25.7	29.8	25.9157
0.4429	29	33.1	29.0071
0.7575	29.7	53.3	29.7701
2.9512	29.4	33.4	29.4462
5.7874	30.3	34.3	30.3907

Impact of segmentation technique on identifying the RoI temperature is shown in Figure 6.

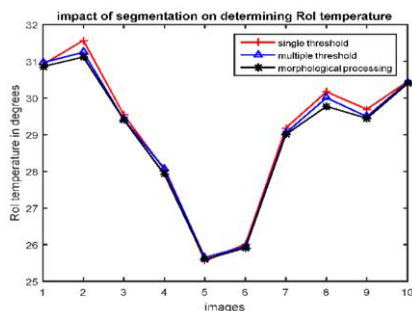


Figure 6. Impact of segmentation technique

## 5 Conclusion and Future Work

In this work, InfraRed Thermography is used for acquiring thermal images for health monitoring of temples, tiger cave and Mamallapuram rock temple. Temperature profile and the Region of Interest are determined using line profiling and segmentation techniques. When the size of the cold spot is less and is of regular shape, then line profiling can be used for describing the cold spot. In that case, a set of few line profiles can be used for describing the cold spot. On the other hand, when the cold spot is irregular and is large in size then segmentation techniques must be used. Of the various segmentation techniques, morphological image processing technique provides accurate segmentation as it removes the undesirable regions completely. In future, semantic segmentation using deep learning techniques can be used. Also in addition to hotspot temperature thermal gradient can also be determined.

## References

- [1] Christopher Brooke. Thermal Imaging for the Archaeological Investigation of Historic Buildings. *Remote Sensing* 2018.10, 1401; doi:10.3390/rs10091401.
- [2] Efstathios Adamopoulos , Monica Volinia , Mario Giroto and Fulvio Rinaudo .Three-Dimensional Thermal Mapping from IRT Images for Rapid Architectural Heritage NDT. *Buildings* 2020, 10, 187; doi:10.3390/buildings10100187.
- [3] Jia-Hao He, Ding-Peng Liu , Cheng-Hsien Chung and Hsin-Haou Huang. Infrared Thermography Measurement for Vibration-Based Structural Health Monitoring in Low-Visibility Harsh Environments. *Sensors* 2020, 20, 7067.
- [4] Sudheera, K., Nandhitha, N.M., Sai, V.P.B.V. Deep Learning Techniques for Flaw Characterization in Weld Pieces from Ultrasonic Signals .*Russian Journal of Nondestructive Testing*, 2020. 56(10).pp. 820–830.
- [5] Sangeetha, M.S., Nandhitha, N.M., Karthikeyan, S. Mathematical Relationship between Hotspot Temperature, Emissivity and Distance in Thermographs for Condition Monitoring of Electrical Equipments Venkatesh, N. *Proceedings of the 2nd International Conference on Trends in Electronics and Informatics* , ICOEI 2018, 2018, pp. 984–988, 8553948.
- [6] Sangeetha, M.S., Nandhitha, N.M. Linear and non linear analysis of the impact of emissivity and distance on hotspot temperature in condition monitoring of electrical equipments by thermal imaging .*Journal of Engineering and Applied Sciences*, 2018, 13(17), pp. 7408–7413.
- [7] S.Hema Kumar et.al, Effective Online Medical Appointment System. *International Journal of Scientific & Technology Research*. Volume 8.Issue 09.September 2019.Pages 803 – 805.

# Face Mask Detection Using CNN

SaiSupriya N<sup>a,1</sup>, Priyanka<sup>b</sup>, RashmiS<sup>b</sup> and Parthasarathy G<sup>b</sup>  
<sup>a1,b</sup>*School of Computing and IT, REVA University, Karnataka, India*

**Abstract:** The COVID-19 pandemic has become an evolving situation all around the globe and the spread is at an alarming rate. Adapting public health-informed hygiene practices can control the transmission of COVID-19, basic measure being wearing a mask. Face detection is the process of identifying faces in a given input image or video and indicating it by drawing a bounding box around the face. In this paper we introduce a deep learning computer vision model to recognise if a person visible through the camera is wearing a mask or not. The deep learning algorithm administered in our work is a transfer learning based Convolutional Neural Network (CNN) and the face detection task is done using the Viola-Jones algorithm approach.

**Keywords:** Face mask detection, Deep learning, Convolutional neural network, Face detection

## 1. Introduction

The COVID-19 pandemic has wreaked havoc all over the world. It has led to colossal loss of human life. The outbreak has had a very adverse impact on the entire economy and human lifestyle. This is caused by a group of viruses called coronaviruses that affect the respiratory tract. Major Symptoms observed are fever, cough, and shortness of breath. The disease is spread when a person touches surfaces contaminated with the virus and touching their face. The trend of wearing face masks in public is rising due to the COVID-19 pandemic across the globe. Scientists proved that wearing face masks helps curb the COVID-19 transmission immensely. People are mandated by laws to wear face masks in public. The main motive of the monitoring process is the detection of anyone who is not wearing a face mask. Face detection is a task concerned with the detection of facial features that appear at different scales, which assists in finding whether there are any faces in a given image approach being the Viola-Jones algorithm based detection using Haar cascade classifiers[4], [7]. Prior to the advent of deep learning based algorithms, feature extraction was performed followed by classification. Some of the various techniques used for feature extraction were SURF, SIFT, local binary patterns, histogram of gradients. Once these features were extracted the classification was performed by any machine learning algorithm like K-means clustering, Principal Component Analysis (PCA) [2],[5], random forests and Support Vector Machines (SVM) [2].

---

<sup>1</sup>Sai Supriya N, School of Computing and IT, REVA University, Bangalore-560064, Karnataka, India.  
E-mail: supriyanagendra12@gmail.com

CNNs extract features directly from images, and these extracted features are learnt while training the network on collected dataset of images and is not pre-trained. The automatic feature extraction aspect of deep learning models makes them highly accurate in computer vision [6]. Deep CNN architecture involves complex models with multiple layers each with an assigned function. They require large image datasets for higher accuracy [1],[2],[3]. The extensive research work done has motivated us to use CNN for the classification task in our work. The proposed CNN architecture capable of detecting masked and unmasked faces can be integrated with pre-installed CCTV cameras. This will aid in tracking safety violations, promote the use of face masks, and ensure a safe working environment.

## 2. Convolutional Neural Network

Convolutional Neural Networks are a class of most widely deep learning pattern recognition algorithms which are designed based on the human brain [2]. CNNs are composed of basic units called neurons. Neurons accept an input and fire an output similar to the neurons in the brain, hence the name. The neuron acts as a placeholder for an activation function, whose main purpose is to introduce non-linearity. Sigmoid, Rectified Linear Unit (ReLU), Tanh etc. are the most frequently used activation functions. The basic layers in CNNs are- Convolutional layer, Pooling layer, and Fully Connected layer [4]. The main feature that makes the CNNs different from other Neural Networks (NNs) is the special mathematical function called Convolution [3], performed in the convolutional layer. This layer consists of a set of filters with parameters which can be visualized as 2D matrices. These filters are slid over the input data across their height and width. The dot product of the values in the filter and corresponding part of the input is computed which outputs an activation map. This is repeated across the depth of the input (i.e., layers) and all the activation maps from each layer are stacked to get the feature map which gives us information about where a specific feature is situated in the input. This map acts as an input to the next layer that is the pooling layer. Pooling layers are used to reduce the spatial information of the feature maps. There are different pooling functions, but max pooling is most widely used. The output from this layer is flattened into a vector and passed to the Fully Connected layer. This layer helps classify the inputs into different categories by training.

## 3. Methodology

The approach we have implemented consists of three basic modules- training the CNN for classification, face detection using the Viola-Jones Algorithm and obtaining the input video stream to carry out the face mask detection task at hand. A flowchart of the methodology is depicted in Fig 1.

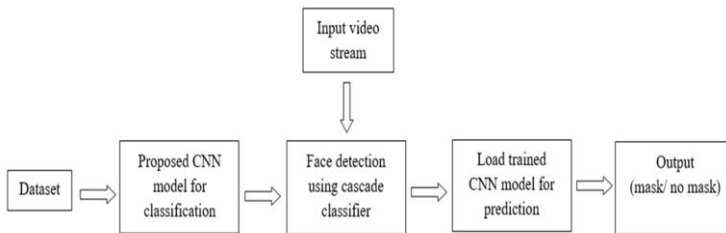


Fig 1: Face Mask Detection flowchart

Figure 1.Face mask detective flowchart

### 3.1. The dataset

The first crucial step is to acquire the image data to train our model for classification. The necessary masked and unmasked images for training the classifier were obtained from Kaggle, which is an online community owned by Google Inc. where various data scientists and machine learning enthusiasts interact and share data . This dataset consists of 3828 images. 1915 images belong to the class ‘with\_mask’ and 1913 images belong to the class ‘without\_mask’ as shown in Fig 2. The dataset was split into test and train modules using the inbuilt function in the sklearn library.



Figure 2.Masked and Unmasked face images

### 3.2. The proposed CNN model

For accurate classification we are using the transfer learning concept where we utilize a pre-trained model as it reduces the computation time and speed the entire process. The pre-trained model we have utilized is MobileNetV2. This model uses depth wise separable convolutions, width multiplier and linear bottlenecks and shortcut connections which was trained on the Imagenet dataset. MobileNetV2 is faster and aids to boost the accuracy of a traditional CNN model. Hence. The pre-trained model was customized, and the architecture of the proposed model is as shown in Fig 3. The base model consists of the MobileNetV2 without the top layers. Images each of (224 x 224 x 3) size are imputed to the model for training. The top layers removed are replaced with the following layers - an average pooling layer with kernel size (7 x 7), a flattening layer, dense layer with 128 neurons with ReLu activation, a dropout layer

with dropout rate 0.5 and lastly another dense layer with 2 neurons and softmax activation. All these layers constitute the head model and are placed on top of the base model set up.

### 3.3. Face Detection

An important task for face mask detection is detecting the faces in the input video stream for which we used the Viola-Jones algorithm for face detection. This algorithm makes use of Haar like features to recognize facial features and thus detects the location of faces [6] which makes it a simple and efficient approach to implement and works efficiently with impressive accuracy. The OpenCV library has pre-defined functions that can implement the face detection by just including the already available predefined haarcascade XML files to perform this task [7]. The face detection is done, and bounding boxes are depicted around the detected faces. The model detects multiple faces visible through the camera simultaneously. The prediction of whether the detected face is masked or not is made using the predict function available in the Keras models package. The bounding boxes appearing are colour coded where a red box with label 'No mask' appears in case the person is not wearing a mask or a green box with label 'Mask' appears when the person is wearing a mask.

### 3.4 Implementation

The proposed computer vision system was implemented using the Keras open-source, software library that is popularly used for implementation of deep learning models. Keras was run with TensorFlow as the backend for fast numerical computations, which makes it highly suitable for building and training this model. Various other python libraries like Numpy, scikit-learn, Matplotlib have been used. The model once built and compiled was trained using training images with a batch size of 32 over 20 epochs for each batch. The learning rate was set to 0.0001 and the loss function used was binary cross entropy. The input, video stream obtained, and face detection was implemented using the OpenCV library.

## 4. Experimental Results

The data considered here for training are a set of images of human faces with and without masks. The model was found to work exceptionally well with the implemented layers, and we could obtain an impressive training accuracy of 99.31%, validation accuracy of 99.35%, training loss of 24.5% and validation loss of about 26%. The following is depicted in the graphs in Fig 3.

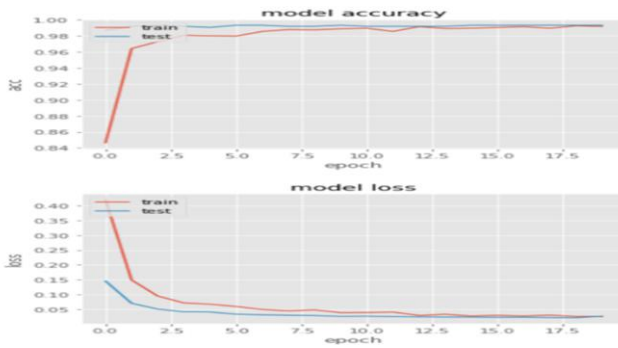


Figure 3. Accuracy and Loss plots

## 5. Conclusion

The COVID-19 pandemic has had a very adverse impact on all aspects of human life, first and foremost being health, economy, lifestyle and so on. Thus, making wearing a mask a crucial task. This brings up the need to overlook if everyone is wearing a mask when in public places. This task can be automated thus serving as an aid to control the spread of the virus. The deep learning model that we have proposed in this paper serves the purpose. This model accepts the live video from the camera as an input and monitors faces detecting whether they are wearing a mask or not.

## References

- [1] M. D. Putro and K. -H. Jo, Fast Face-CPU: A Real-time Fast Face Detector on CPU Using Deep Learning.2020 IEEE 29th International Symposium on Industrial Electronics (ISIE). Delft, Netherlands, 2020, pp. 55-60
- [2] Sanghvi, Kavish and Aralkar, Adwait and Sanghvi, Saurabh and Saha, Ishani .A Survey on Image Classification Techniques .November 25, 2020.
- [3] Dhillon, A., Verma, G.K. Convolutional neural network: a review of models. Methodologies and applications to object detection., ProgArtifIntell 9, 85–112 (2020).
- [4] M. S. Ejaz and M. R. Islam.Masked Face Recognition Using Convolutional Neural Network, 2019 International Conference on Sustainable Technologies for Industry 4.0 (STI), Dhaka, Bangladesh, 2019, pp. 1-6.
- [5] S.Hema Kumar, J.UdayKiran, V.D.AKumar, G.Saranya, Ramalakshmi V.Effective Online Medical Appointment System. International Journal of Scientific & Technology Research, Volume 8, Issue 09, September 2019, Pages 803 – 805.
- [6] V.D.Ambeth Kumar, Dr.M.Ramakrishnan, V.D.Ashok Kumar and Dr.S.Malathi (2015) .Performance Improvement using an Automation System for Recognition of Multiple Parametric Features based on Human Footprint.for the International Journal of kuwait journal of science & engineering, Vol 42, No 1 (2015), pp:109-132.
- [7] V.D.AmbethKumar et.al .Facial Recognition System For Suspect Identification Using A Surveillance Camera.Pattern Recognition and Image Analysis (Springer), Volume 28, Issue 3, pp 410–420, 2018. (DOI: 10.1134/S1054661818030136)
- [8] V.D.Ambeth Kumar and M.Ramakrishan."Employment Of Footprint Recognition System", Indian Journal of Computer Science and Engineering (IJCSE) Vol. 3 No.6 Dec 2013.
- [9] Ramya,T.et.al.Personalized authentication procedure for restricted web service access in mobile phones. Applications of Digital Information and Web Technologies (ICADIWT).2014, Page(s):69 - 74, Bangalore, India (ISBN:978-1-4799-2258-1).



# Study on Intelligent Data Algorithms Implemented in Wearable for Sports Applications

N.Nithya<sup>a,1</sup> and G.Nallavan<sup>b</sup>

<sup>a</sup>Research Scholar, Dept of AST&T, TNPESU, Chennai

<sup>b</sup>Assistant Professor, Dept of AST&T, TNPESU, Chennai

**Abstract:** Technological transformation is unlocking new opportunities in wearable devices used in sports application. Nowadays training the sports involves the use of integrating smart sensors, cameras, internet of things and intelligent data algorithms into a device which is wearable making the players to achieve their maximum performance. These smart devices replace the coach and manage all aspects of technical training except for the physical training given by the real coach. This paper provides a comprehensive study on the intelligent data analysis made on the data acquired from sensors to give a meaningful sense to it. The smart training methods employed currently in various sports are identified and presented. The future directions in this area of research are also presented.

**Keywords:** Wearable devices, intelligent data algorithms, sensors, technical training, sports

## 1. Introduction

The technological boom has influenced in all areas of human life. Smart devices have changed the way of looking the world. Sports field is not an exception. Wearables take new dimension in monitoring sports activities of the player. These devices incorporated with smart algorithms help the player to understand his performance and help him to compete to next level. Due to developments in internet and cloud services the collected data from sensors can be worked in a detailed manner. Here clever algorithms can be applied which extracts the features, train the data set and can be tested to verify its accuracy. With these resources the devices now become smart Artificial Intelligent (AI) devices which will help the player to train himself and achieve better results. Section 2 discusses the role of wearables in smart training. Section 3 briefs the sensors that are commonly used in devices. Section 4 summarizes the intelligent approach used in the sports wearables and the results obtained. Section 5 lists the challenges faced and section 6 concludes with the limitations and identifies the scope of futureresearch.

---

<sup>1</sup>Nithya .N , Research Scholar, Dept of AST&T, TNPESU, Chennai;  
E-mail: nnithyapanimalarece@gmail.com.

## 2. Wearables in Sports Training

The role of coach for a player is very important. Unfortunately all aspirant players do not get their dream coach. Sometimes financial support also poses some problem. So, wearable technology could reduce this burden by providing solution to the above problem. Intelligent algorithms incorporated in these devices gives clues to the player so that he can understand his game profile and take necessary steps to correct and achieve his target.

Two important sections in wearable device are,

1. Hardware
  - a. Sensor selection
  - b. Noise removal
  - c. Communication to the decision making subsystem
2. Software which takes decision based on acquired signals.

The tasks performed during training require physical effort and it is a continuous process where the ultimate goal is to improve the perfection in the game played. The various stages involved in sports training are,

- Data acquisition
- Intelligent data analysis
- Assessment
- Target realization

The flow diagram for the sports training is shown in figure 1,

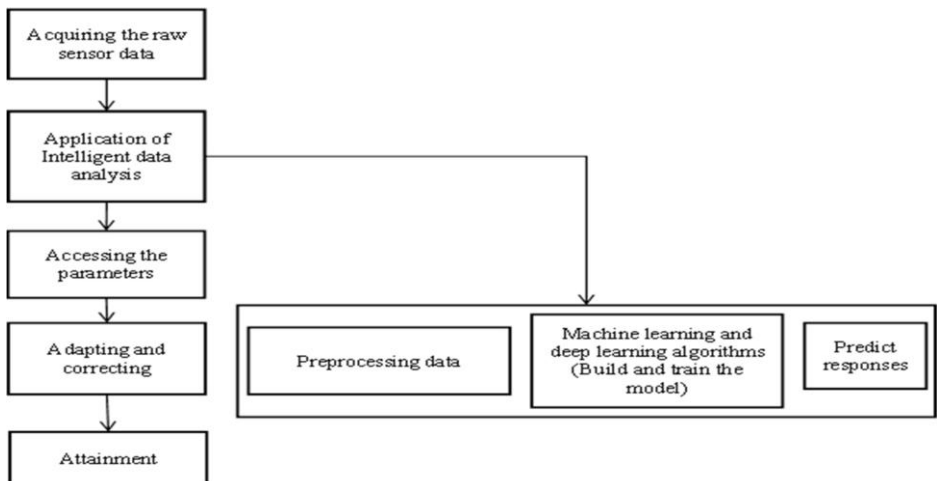


Figure 1. Flow diagram for sports training

### 3. Sensors

The important consideration for developing a wearable device is the selection of sensors. The sensors should be reliable, small in size, light in weight and durable. The data's from sensors can be used in activity recognition i.e. understand the body kinematics and movement parameters. The machine learning algorithms can be applied on the collected data's to bring out predictions. To get best results the user has to select the suitable algorithm to get the desired insight. The algorithm can be supervised or unsupervised. But all data processing algorithms cannot run on the device itself due to lack of its computational capacity, memory constraints and power back up. So with Bluetooth or wireless module the data's can be transported to a mobile or cloud services where intelligent algorithms can be performed to aid the player in decision making. This virtual coach assists the player in his training replacing the actual trainer. The various sensors deployed in sports wearables are inertial measurement unit which involves accelerometer, gyroscope and magnetometer, pressure sensor array, force sensor, motion sensor etc.

### 4. Intelligent data algorithms in sports

Intelligent data algorithms and data set can provide a method to analyze the performance parameter of an athlete and can improve his training plan to achieve the best results. Table 1 summarizes the information such as the name of the sport, the sensors used, the features detected, the goal, the classification algorithm and the accuracy obtained.

**Table 1.** Studies identified in sports wearable sensors with intelligent approach

Ref	Sport	Sensor	Features	Aim	Approach	Result
[1]	Basket ball	Motion sensor	Body acceleration, Gesture	Automatic recognition of basketball training type	Support Vector Machine (SVM)	99.5% accuracy with SVM algorithm or activity recognition
[2]	Basket ball	Accelerometer and Gyroscope	Arithmetic mean and Standard deviation	Classify the action of players	k-Nearest Neighbours (k-NN), Random Forests	Random Forests was more accurate than k-NN
[3]	Fitness	Multiple acceleration sensor on several parts of body/distributed across body	Mean, Maximum, Minimum, Range, Standard deviation, Root mean square	Examine the participant performance on collected data set from a smart wrist wearable device	k-NN, Linear SVM, Naïve Bayes with Gaussian kernel & Bernoulli(NB), SVM polynomial, Decision Tree (DT), Long Short-term Memory (LSTM)	LSTM is best with an accuracy of 92.5%

[4]	Fitness	Accelerometer and Gyroscope, Pulse rate sensor	Mean, Standard Deviation	Classify the indoor exercise activity such as biceps curl, Row, Pushup, Sit up, Squat and Triceps curl	k-NN,SVM, DT	95.3% accuracy for activity recognition and 99.4% for repetition count
[5]	Running	Wireless sensor network deployed in the area of training. MTS 400 sensor board, Crossbow MOTE2 IPR 2400	Mean, Standard Deviation	Develop a prototype to support athlete with ambient intelligent algorithms	k-NN, SVM, Spline Interpolation	Classification system achieves and accuracy of 80% in spline interpolation
[6]	Soccer	Data form video recordings	Mean, Maximum, Minimum, Standard deviation	Classify athlete position and predict the number of goals scored in the game	SVM, RF, Linear Regression (LR)	82% accuracy is achieved in RF and LR
[7]	Football	Data from data set at Tottenham Hotspur Football club	Maximum, Minimum	To predict the recovery time after injury without official diagnosis	SVM Radial basis function (RBF) kernel and polynomial kernel, Gaussian process with RBF and Laplace kernel, Artificial Neural Network (ANN)	Accuracy for SVM-98.43%, Gaussian process-97.4%,ANN-98%
[8]	Table Tennis	IMU sensor	Mean, SD, Skewness, Kurtosis	To detect and classify the stroke in table tennis	SVM linear, SVM RBF, RF, k-NN	SVM linear-95.6%, SVM RBF-96.7%, RF-95.7%, kNN-94.7%
[9]	Tennis	Video recordings	3 layer LSTM network	Classifies the activities in tennis shots	LSTM	81.23% to 88.16%
[10]	Volley ball	IMU, EMG sensors and video cameras	Mean, SD	Identifying and classifying the not allowed moves and providing feedback in training sessions	LSTM	F1 score of 0.74 for labels with 2 classes

[11]	Weight lifting	IMU	Mean, Variance, SD	Classifying the weight lifting exercises	SVM, Linear Discriminant Analysis (LDA)	94.36% accuracy in SVM
[12]	Cricket	Recorded videos	-	Develop AI training system to be used as a coach for trainees to become expert in batting, bowling and fielding	Fuzzy, ANN	Good classification accuracy
[13]	Cricket	Data form IPL matches	Mean, SD	To identify the best set of attributes in the player in the match played	SVM	81%
[14]	Golf	Strain gauge sensor, 3-axis accelerometer and 3-axis gyroscope	-	Investigate Golf swing data classification method	Convolutional Neural Network (CNN), SVM	95% of accuracy is achieved in deep CNN than SVM which is 86.8%

### 5. Challenges

Plenty of research is open in the field of sports training. Some of the challenges to be addressed are:

1. The authors have shown results conducted with certain method and approach and tabulated their findings. But they are not aware whether these methods will be adopted by all athletes over long term. So the researchers can share their views and results with the real world. Can interact with professional athlete and conduct more experiments and provide a wider scope to researchers.
2. Every player is unique, so integrating intelligent algorithms might not provide expected results for all as the body and thinking are different foreveryone.
3. All most all the design of wearables with intelligent algorithms is still in development phase, it means they are available in prototypes only. So with only proper validation these prototypes can be brought out as a commercialproduct.

### 6. Conclusion

This paper studies the various intelligent data algorithms proposed and implemented in the field of sports training. With technology the minute details of the game can be perceived. The accuracy and complexity of the models involved in this research vary due to the different classification problems that each model is tasked with. The study observes only few sports are concentrated and research should focus on the design and

implementation of wearable in other sports also. Moreover the security issues in data handling also have to be considered.

## References

- [1] Acikmese Y, Ustundag BC, Golubovic E. Towards an artificial training expert system for basketball. In Proceedings of the 2017 10<sup>th</sup> International Conference on Electrical and Electronics Engineering; 2017 Nov 30– Dec 2; Turkey, ELECO; p.1300–1304.
- [2] Holzemann A, Van Laerhoven K. Using Wrist-Worn Activity Recognition for Basketball Game Analysis. In Proceedings of the 5th International Workshop on Sensor-Based Activity Recognition and Interaction. 2018 Sep 20-21; ACM Press: New York, NY, p.1–6.
- [3] Baumbach S, Bhatt A, Ahmed S, Dengel A. Towards a Digital Personal Trainer for Health Clubs—Sport Exercise Recognition Using Personalized Models and Deep Learning. In Proceedings of the 10th International Conference on Agents and Artificial Intelligence; 2018 Jan 16-18; Setubal, Portugal. p.438–445.
- [4] Das D, Busetty SM, Bharti V, Hegde PK. Strength Training: A Fitness Application for Indoor Based Exercise Recognition and Comfort Analysis. In Proceedings of the 2017 16th IEEE International Conference on Machine Learning and Applications (ICMLA); 2017 Dec 18-21; Cancun, Mexico; p.1126–1129.
- [5] Vales-Alonso J, Lopez-Matencio P, Gonzalez-Castano FJ, Navarro-Hellín, H, Banos-Guirao PJ, Perez-Martínez FJ, Martínez-Álvarez RP, Gonzalez-Jimenez D, Gil-Castineira F, Duro-Fernandez R. Ambient Intelligence Systems for Personalized Sport Training. *Sensors*. 2010 Mar;10:2359–2385.
- [6] Apostolou K, Tjortjijis C. Sports Analytics algorithms for performance prediction. In Proceedings of the 2019 10th International Conference on Information, Intelligence, Systems and Applications (IISA); 2019 July 15-17; Patras, Greece; p.1–4.
- [7] Kampakis S. Comparison of Machine Learning Methods for Predicting the Recovery Time of Professional Football Players after an Undiagnosed Injury. *2013 Sep*;1969:58-68.
- [8] Blank P, Hobach J, Schuldhaus D, Eskofier BM. Sensor-based stroke detection and stroke type classification in table tennis. In Proceedings of the 2015 ACM International Symposium on Wearable Computers—ISWC '15; 2015 Sep 7-11; Osaka, Japan: ACM Press; p.93–100.
- [9] Mora SV, Knottenbelt WJ. Deep Learning for Domain-Specific Action Recognition in Tennis. In Proceedings of the 2017 IEEE Conference on Computer Vision and Pattern Recognition Workshops (CVPRW); 2017 July 21-26; Honolulu, HI, USA; p.170–178.
- [10] Holatka AK, Suwa H, Yasumoto K. Volleyball Setting Technique Assessment Using a Single Point Sensor. In Proceedings of the 2019 IEEE International Conference on Pervasive Computing and Communications Workshops (PerCom Workshops); 2019 Mar 11-15; Kyoto, Japan; p. 567–572.
- [11] Crema C, Depari A, Flammini A, Sisinni E, Haslwanter T, Salzmann S. IMU-based solution for automatic detection and classification of exercises in the fitness scenario. In Proceedings of the IEEE Sensors Applications Symposium (SAS); 2017 Mar 13–15; Glassboro, USA; p.1–6.
- [12] Mandot C, Chawla R. Artificial intelligence based integrated cricket coach. In International Conference on Advances in Computing Communication and Control. Springer; 2013 Jan 18-19; Berlin/Heidelberg, Germany; p.227–236.
- [13] Somaskandhan P, Wijesinghe G, Wijegunawardana LB, Bandaranayake A, Deegalla S. Identifying the optimal set of attributes that impose high impact on the end results of a cricket match using machine learning. In Proceedings of the IEEE International Conference on Industrial and Information Systems (ICIS). 2017 Dec 15-16; Peradeniya, Sri Lanka; p.1-6.
- [14] Jiao L, Wu, Bie R, Umek A, Kos A. Multi-sensor Golf Swing Classification Using Deep CNN. *Procedia Comput. Sci*. 2018 Jan; 129:59–65.

# Evaluation of Existing Methods in Cervical Cancer Detection and Related Issues

Saravanan.M.S.<sup>a,1</sup> and A.Rajesh<sup>b</sup>

<sup>a</sup>Professor, Dept of AI, Saveetha School of Engineering, Saveetha Institute of Medical and Technical Sciences, Chennai, India

<sup>b</sup>Associate Professor, Dept of CSE, Vels Institute of Science, Technology and Advanced Studies, Chennai, India

**Abstract.** In day-to-day life cancer is the severe disease to cure. This paper deals about the cervical cancer and its related issues. The cervical cancer is a preventable disease, but it is one of the second most leading causes of cancer deaths in women. There are two main types of cervical cancer namely squamous cell carcinoma, adenocarcinoma. The major stages of cervical cancer will be dealt by evaluating with clear diagrams and also the major risk factors of cervical cancer are discussed. Finally the various treatment methods of cervical cancer are used to analyze and present the related issues.

**Keywords.** Cervical cancer, women, squamous cell carcinoma, adenocarcinoma, risk factors.

## 1. Introduction

Cervical cancer is a preventable disease, but it is one of the second most leading causes of cancer deaths in women. The primacy cause of cervical cancer is the infection is high risk types of human papilloma virus (HPV). HPV infected through sexual relation in early life and unusual sexual activity. Cervical cancer affected by mainly 2 HPV types are 16 and 18 is the most common cancer affected in cervix. Cervical cancer termed as benign and malignant growth of cells and tissues.

### 1.1. Morphology of cervical epithelium

There are two types of epithelium present in the surface of the cervix. The lining of the surface is found on skin and it is present in inside of the hollow organs [1]. The ectocervix is covered by squamous epithelium and the canal is covered by columnar epithelium shown in the Figure 1. The squamous epithelium contain plump and deep multiple layers like flatter cells. The columnar epithelium is a tall, looks like a single layer of cells and extends from the portion of ectocervix [2]. It is a thin, fragile than the squamous cells and it contain multiple glands with the lubrication present in the canal [3]. The two types of epithelium meet in the junction called Squamous Columnar Junction (SCJ) shown in Figure 2. The junction is sharp line due to thickness of two

---

<sup>1</sup>Saravanan.M.S, Professor, Dept of AI, Saveetha School of Engineering, Saveetha Institute of Medical and Technical Sciences, Chennai, India.;  
E-mail: saranenadu@gmail.com

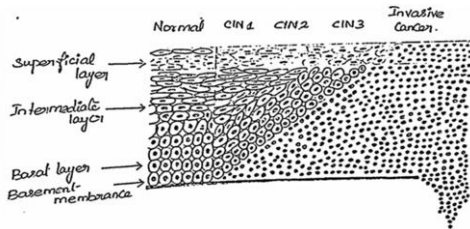


Figure 1. Columnar epithelium changes

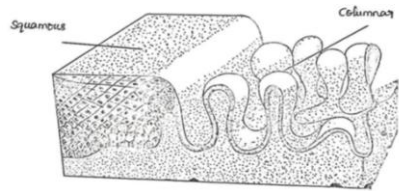


Figure 2.Squamo-Columnar Junction

epithelium layers [4]. This SCJ junction varies depends on woman’s age, hormonal, birth, pregnancy status.HPV infection is one of the most common reasons for affecting cervical cancer. Squamous cell cancer is presence in the ectocervix and the affected level of this cancer is 90%. The adenocarcinoma affected in the place of endocervix and the affected level is 10% [5].The normal cervix consists of exocervix and endocervix. The excocervix is shielded by nonkeratinizing and stratified squamous epithelium [6]. The endocervix is limed with the layer of columnar epithelium and reserve cells are present with complex folding. There are two types of glandular cells namely ciliated and non-ciliated. The ciliated cells are present few and non-ciliated cells are secreting the mucus [7]. For aged person, the metaplastic squamous cells are replaced by the distal part of the cervix. The transformation zone (ectropion) present in the junction of squamous columnar of the exocervix. The ectropion is placed between the squamocolumnar junction and metaplastic squamous epithelium. The immunohistochemistry technique used to observe the endocrine and melanotic cells present in the cervix [8].

**2. Stages of Cervical cancer**

Stages are indicating to evaluate assess the tumor has spread to distant organs of the body. This stages based on physical examination, scanning images and biospies of samples. At stage-1, the cancer is found in the uterus and its spread into the deeper tissue of the cervix. This stage of cancer is not spread to other organs of the body as shown in the figure 3. This stage of cancer is divided into sub stages [9].

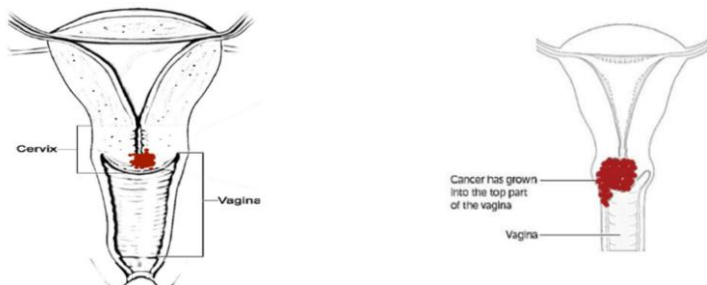


Figure 3. Stage-1 and Stage-2 Cancer

At stage-1A, the invasive cancer is identified by microscope. The stromal invasion measured 5mm in depth and not more than 7mm width and the depth of the invasion is not more than 5mm from the base of normal epithelium [10]. 1A is the invasion of stroma measured about not more than 3mm in depth and no more than 7mm in wider.



IB is the tumor size is larger and their lesions constricted to the cervix and the pre-cancer lesions are greater than the stages 1A. 1B1 is the tumor size may be 5mm or more than in depth and less than 2cm wider. The centimetre size of the tumor is compared to the width of pen or pencil. 1B2 is the tumor size is measured about 2cm or more than in depth and the width of the tumor is less than 4cm. 1B3 is the tumor size is may be 4cm or more than in width. At Stage-2, the cancer present inside the area of pelvic and spread behind to nearby area of uterus, vagina and near tissue of the cervix. This tumor is not spread to other organs of the body as shown in the figure 4.



Figure 4. Stage-3 and Stage-4 Cancer

The Stage-2A, the tumor affects the area of upper two-thirds of vagina and it's not spread to the tissue of parametrical area of the cervix. The 2A, the tumor size is less than 4cm wider, 2A, the tumor size is may be 4cm or more than in width. The Stage-2B, the cancer spread to the tissue of parametrical area and it does not reach the wall of pelvic. The Stage-3, the tumor affects the mower third part of vagina and spread to the wall of the pelvic. The symptoms of tumor includes kidney swelling (hydronephrosis), syops kidney functioning, region of lymph and there is no spreading of distant organs as shown in figure 4.

### 3. Risk factors of Cervical Cancer

There are various risk factors which increase the chances for developing cervical cancer as shown in table 1. The focus of these factors for women is important to know to do regular Pap test for detecting cervical cancer earlier [10].

Table 1. Factors contributing to cervical cancer

Factors	Range (%)
Smoking prevalence (%), women	2.3[1.7 to 2.8]
Total fertility rate (live births per women)	2.3
Hormonal contraception use (%) (pill, injectable or implant), among women	3.2
HIV prevalence (%), adults (15-49 years)	-

### 4. Treatment of Cervical cancer

Its aim is to destroy or remove the area affected cervical cancer in the cervix identified as a pre-cancer. There are two methods are ablative or excisional. The ablative method

is to destroy abnormal tissue by burning or freezing and the excisional methods are done by surgically to remove abnormal tissues.

#### *4.1. Cryotherapy*

An ablative method is used to remove the precancerous area present in the cervix by freezing. To apply a cryoprobe (highly cooled metal disc) in the place of cervix and the abnormal or normal areas are frozen and covered. The cryoprobe are contained a tank filled by carbon-dioxide or nitrous oxide gas. This method is performed by health-care [11-15] provider trained in cryotherapy. This technique done by 15 minutes with slight discomfort and it may be performed without anaesthesia.

#### *4.2. Loop electrosurgical excision procedure (LEEP)*

A loop made of thin wire is used to remove the affected area of the cervix and the wire powered by an electrosurgical unit. The loop cuts and coagulates and using an electrode ball for completing the coagulation. This procedure aim is to destroy the abnormal lesion of the transformation zone. The removed tissue sent to the laboratory for assessing the lesion in histopathological examination. This procedure serves for two purposes: remove the lesion and provide the specimen for examining the histopathology. The procedure completed about 30 minutes under local anaesthesia. In this procedure, the patient should wait for few hours or assurance of bleeding does not occur. It is like a surgical procedure and performed by a gynaecologist and it's carried out in the hospitals.

#### *4.3. Cold knife conization*

This procedure removes the portion of cone-shaped area of the ectocervix and Endocervix. The removed depends upon the tissue size of the cancerous lesion and the tissue sent to the laboratory for diagnosis. This procedure is done only in the hospital with health-care trained providers (gynaecologists). This method completed about less than one hour under anesthesia. After procedure, the patient should be discharged to the next day.

### **5. Observations**

The observations are listed below as following first it study about the cervical cancer and their symptoms, risk factors and screening methods, Human Papilloma Virus (HPV) is the main reason for the cause of cervical cancer, There are several manual screening techniques for detecting the cervical cancer was observed and the treatment of cervical cancer observes to reduce the infection of cancer affected in the cervix.

### **6. Conclusion**

This paper presents the detailed information of cancer disease. The cancer development process sheds light on not only the development of cancer, but later this information will help in creating the feature set proposed here. The cell changes progresses from normal to cancer cell changes its color, texture, appearance, etc., and these visible characteristics are called abnormalities and the staging process and classification processes help in telling the severity of the cancer. The different abnormalities and

classification of cancer system and the virus responsible of cancer are presented here in detail. This paper gives pre-essential information prior to creating a feature set for an automated system.

## References

- [1] Loay, K. Abood, Raad A. Mohammed, Image Segmentation Using Superpixel Based Split and Merge Method. *Iraqi Journal of Science*, Vol 56, No.1A, pp:233-237, 2015.
- [2] Zhi Lu, Gustavo Carneiro, and Andrew P. Bradley, Automated Nucleus and Cytoplasm Segmentation of Overlapping Cervical Cells, PubMed DOI: 10.1007/978-3-642-40811-3\_57.
- [3] Amanpreetkaur, Ashishvarma, Ssiet, Derabasi, The Marker-aBased Watershed Segmentation- A Review, *International Journal of Engineering and Innovative Technology (IJEIT)* Volume 3, Issue 3, September 2013.
- [4] Kuan Li, Zhi Lu, Wenyin Liu, Jianping Yin, Cytoplasm and nucleus segmentation in cervical smear images using Radiation GVF Snake, *Pattern Recognition Impact Factor: 3.1* Doi: 10.1016/J.Patcog.2011.09.018, April 2012
- [5] Marina E.Plissiti and ChristopjorosNikou, Overlapping Cell Nuclei Segmentation Using a Spatially Adaptive Active Physical Model, *IEEE Transactions on Image Processing*, Vol. 21, No.11, November 2012.
- [6] Maykel Orozco-Monteagudo, CosminMihai, HichemSahli and Alberto Taboada-Crispi, Combine Hierarchical Watershed Segmentation and SVM Classification for Pap Smear Cell Nucleus Extraction, *Computacion u Sistemas* Vol. 16 No.2, pp 133-145 , 2012.
- [7] RaminMoshavegh, BabkEheshtamiBejnordi, Andrew Mehnert, et al, Automated segmentation of free-lying cell nuclei in Pap smears for malignancy-associated change analysis, 34th Annual International Conference of the IEEE EMBS San Diego, California USA, 28TH August- 1st September 2012.
- [8] Weimiao Yu, HweeKuan Lee, SrivatsHariharan, Level Set Segmentation of Cellular Images Based on Topological Dependence, Springer-Verlag Berlin Heidelberg G.Bebis et al. (Eds): ISVC 2008, Part I, LNCS 5358, pp. 540-551, 2008.
- [9] BalasubramanianGopinath, NatesanShanthi, Automated Segmentation Of ELA Cancer Cells in Microscopic Images for Evaluating the Cytotoxic Effect of Selected Medicinal Plants, *Journal of Medical and Biological Engineering*,32(4): 279-289.
- [10] MehryarEmambakhsh, HoseinEbrahimnezhad, Mohammad HosseinSedaaghi, Integrated Region-Based Segmentation using Color Components and Texture Features with Prior Shape Knowledge, *Int. J.*
- [11] Ambeth Kumar.V.D, S. Sharmila, Abhishek Kumar, A. K. Bashir, Mamoon Rashid, Sachin Kumar Gupta & Waleed S. Alnumay . A novel solution for finding postpartum haemorrhage using fuzzy neural techniques. *Neural Computing and Applications* (2021) (<https://doi.org/10.1007/s00521-020-05683-z>)
- [12] Hema Kumar S, J.UdayKiran, V.D.AKumar, G.Saranya, Ramalakshmi V.Effective Online Medical Appointment System.*International Journal of Scientific & Technology Research*, Volume 8, Issue 09, September 2019, Pages 803 – 805.
- [13] Ambeth Kumar.V.D and S. Sharmila.An Clinical Study on Finding Hypothermia and Postpartum Haemorrhage Using Temperature. *International Journal of Psychosocial Rehabilitation*, Vol. 24, Issue 05, pp: 2624- 2629, 2020.
- [14] S.V. Ruphitha et.al, “ Management of Major Postpartum Haemorrhage by using Zigbee protocol - A Review “, 2021 6th International Conference on Inventive Computation Technologies (ICICT) (DOI: 10.1109/ICICT50816.2021.9358757 )
- [15] M. Indhumathi et.al , “Healthcare Management of Major Cardiovascular Disease-A review”, 2021 6th International Conference on Inventive Computation Technologies (ICICT), (DOI: 10.1109/ICICT50816.2021.9358519 )

# Survey on Food Recognition System Using Machine Learning

D.GaneshGaurav<sup>a,1</sup>, Parthasarathy G<sup>b</sup>,Dhananja<sup>b</sup>, Chiranthan YC<sup>b</sup>, KomalBharti<sup>b</sup>  
<sup>a,b</sup>School of Computing and IT, REVA University, Karnataka, India

**Abstract.** Food recognition system is essential framework in modern world, the motivations behind this recognition systems are assessing calorie and nutrients of food varieties and show the formula of the food. As all the processing on picture recognition is performed on a personal digital assistant (PDA), the framework doesn't have to send pictures to a server and runs solution to a normal advanced mobile phone in a constant one. Spontaneous image-based food acknowledgment is an isolated inspiring task. Conventional picture analysis preparing methodologies have fallen off with low order classification prediction in the past, while deep learning methodologies permitted the recognizable proof of food things. To recognize food items, a client ought to need to draw bounding boxes by contacting the screen first, and afterward the framework starts food thing acknowledgment inside the showed bounding boxes. Moreover, the framework assesses the direction of food areas with the higher SVM (Support Vector System) yield score is expected upon to be acquired, show it as an arrow on the screen to request that a client move an advanced mobile phone camera. This acknowledgment cycle is performed on and on about once each second. We will carry out this task as an Android advanced mobile phone application to utilize numerous CPU cores effectively for modern real-time food recognition system.

**Keywords.**Machine Learning, Image Analysis, SVM

## 1. Introduction

The new age Smartphone's have completely transformed the way we live, due to the improved digital payments technology people are looking for an easy and effective way to access information without wasting time. The outcome of this project will be that the user will simply have to scan the food and all the information, which is the food preparation method, the origin, calories count is displayed in a very informative way, this helps user to access all the information without actually searching the web which may not have an accurate data.

The appearance of deep learning innovation has upheld various intelligent zones by giving advanced techniques and strategies for improved food object prediction and recognition, in view of images object or videos. In software engineering, especially in computer vision application and artificial intelligence, image analysis is a basic task, with different new improvements upcoming from object recognition with deep learning techniques

---

<sup>1</sup>GaneshGaurav,School of Computing and IT, REVA University, Karnataka, India  
E-mail id: d.ganeshgaurav@gmail.com,

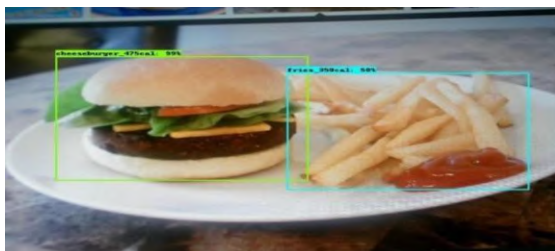


Figure 1. Recognising food items

In this paper we will carry out deep learning designs reliant on convolutional neural networks (CNN) which are very productive in picture recognition system. These structures use a course of convolution layers and activation functions. The plan of the amount of layers and the amount of neurons in each layer, the choice of activation functions and training advancement calculation are indispensable. The GPU execution of CNN with include feature extractors proposed for building recognition, learned in a coordinated way and achieve commonly great results.



Figure 2. Detecting Multiple Food Items

## 2. Literature Survey

This paper is all about a smart application which is been discussed, with the help of mobile edge registering idea that empowers clients to evaluate and analyse their food consumption and backing nourishing dynamic. Mobile edge process to offload system calculations and correspondences to the edge is the methodology utilized, which surely help saving battery life, expanding the preparing limit, and improving client solace. In system creation we propose an a loosely coupled network for a savvy food scanner and afterward execute it utilizing different IoT sensors. Previously, the innovation patterns began to uncover the limits of clouds to host smart applications. A bunches of advancements in the space of Internet of Things (IoT), Big Data, and Deep learning supported the improvement of brilliant applications which for sure uncovered information ingestion as a significant clog of incorporated cloud solutions [1]. In the third paper they presented a study of a novel sensor system for real-time food substantiate. Smartphone videos, pattern recognition and image processing is being used by this sensor system. It has the capacity of Concurrent Version System (cvs.) that capture information of any food sample. The main aim is to replace human visual system in food substantiate with the help of high- level understanding ,soft sensor of

food substantiate through the accession, processing and analysis of digital images. The association between image attributes and quantitative data about food authenticity are used to determine the pattern, and hence new food samples are predicted [2]. In the fourth paper we have seen that the activity based on Smart watch can easily form basis of health applications and in biomedical, which includes applications that track user's eating habit[7-16]. The outcome of this paper accurately identify a large variety of activities in smart watches including hand-based and eating based activities that a smartphone cannot recognize effectively [3].

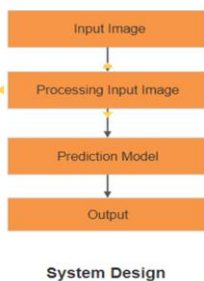
### 3. Proposed System

The existing model has a recognition system which recognizes the type of food (like e.g. Burger). The model which we are going to propose will recognize the food item (like e.g. Burger) and also shows its recipe and nutrition contents in that food item. In our proposed system for food picture classification, as a first step toward the improvement of a portable application, it provides dietary advice to diabetic and other patients by indicating the amount of calories, sugar content, carbs etc. in that food item. We will be developing the application in a form which the user must use this as a one stop destination for food information and this will eliminate the problems like false information's and time spent to search.

### 4. Problem Definition

The existing model has a recognition system which recognizes the type of food (like eg:Burger). The model which we are going to propose will recognize the food item (like eg: Burger) and also shows its name and its recipe. In our proposed system for food picture classification, as a first step toward the improvement of a portable application, it provides dietary advice to diabetic and other patients by indicating the amount of calories ,sugar content, carbs etc. in that food item.

### 5. System Design



**Figure.3** System Design

*Input Image:* Here we feed the image as an input by capturing the image of the food using our app.*Processing Input Image:* Before sending the picture to the Prediction model the image must be processed.In this processing phase the image will be cropped and only the required features will be extracted for prediction.*Prediction Model:*Processed image is fed into prediction model. This model will classify the image of the food fed to it by analysing the patterns of the image.*Output:* After this complete process the output will be given on the screen. This output can the name of

the food, recipe of the food.

## 6. Methodology

**Data Collection:** We gather food pictures by taking image or via looking through web images and fabricate a picture dataset index to use in preparing a complex recognition model for food things. **Data Cleaning:** This is to recognize and eliminate any possible mistakes and copy information, to make a reliable dataset. This improves the idea of the training data for investigation and enables exact decision making. **Training Data Set:** This is the real dataset that we will use to train the model. The model will analyze and gains from this information gave. **Validation Data Set:** The approval collection is primarily used to assess the given framework, yet this is for frequent assessment. We utilize this information to fine-tuning the model hyper parameters. Consequently, the model occasionally investigates this information, yet it won't ever gain from this. We utilize the validation outcomes and update to more higher level hyper parameters. Along these lines, the validation set will influence the model, yet just in indirect way. The validation set is otherwise called the set of development. This makes sense the dataset helps during the "advancement" phase of the model. **Testing Data Set:** The Test dataset is just utilized once the model is totally prepared by utilizing the train and validation sets for the model. The test set is essentially what is utilized to assess the competing models. Large numbers of the occasions the validation set is utilized as a test set, yet it's anything but a decent practice. The test set is for the most part in the administration. It contains deliberately accumulated information that navigates the different classes of model would confront when it is taken truly.

## 7. Expected output and Result

After completion of this project, a lens app is created for smartphones where a box is displayed on the phone screen. So, users can scan by pointing the lens towards the food and tapping on the screen. Then the application will recognize the food, after which it will show the name of the food item, its recipe and nutrition contents.

## 8. Applications

1. Useful for diabetic and other patients to maintain their dietary plans.
2. When a user visits any hotel, this app helps them know the recipe of the food they have ordered.
3. For users who want to maintain a healthy and fit body, this app helps them by providing appropriate nutrition contents in the food.

## 9. Conclusion

The food culture is a growing rapidly and the accurate access to data is very much required more than ever, we propose to solve these problems and provide user with the correct data they need which will make user to not spend more time to search for the data they need, rather they can simply scan the food and get all the information.

**References**

- [1] BahmanJavadi, Quoc Lap Trieu, Kenan M. Matawie,Rodrigon.Calheiros. Smart Food Scanner BasedOn Mobile Edge Computing . IEEE International Conference On Cloud Engineering (Ic2e), Page No. 20-27, May- 25,2020.
- [2] Weiransong,Hui Wang, Jiangnanfeng, Use Of Smartphone Videos Andpattern Recognition For Food Authentication , Sensors And Actuators Bchemical,Researchgate,June-05,2020.
- [3] Avinashpalve, Snehal More, ShivaniChaudhari, Akshaykatke, Karthiekampassi, An Android Based Health Monitoring System Using Machine Learning , Irjet, Volume:03, Sep-2016.
- [4] Yoshiyuki Kawano, Keijiyanaai, Real-Time Mobile Food Recognition System,2013.
- [5] GianluigiCiocca,Paolonapoletano,RaimondoSchettini, Food Recognition: A New Dataset, Experiments, And Results ,Ieee Journal Of Biomedical And Healthinformatics, Volume: 21,May-2017.
- [6] Ayush Jain, MohanaMohana, Real Time Object Detection And Tracking Using Deep Learning And Opencv, July 2018.
- [7] S.Hema Kumar, J.UdayKiran, V.D.Akumar, G.Saranya, Ramalakshmi V.Effective Online Medical Appointment System. International Journal Of Scientific & Technology Research, Volume 8, Issue 09, September 2019, Pages 803 – 805.
- [8] Ambeth Kumar.V.D, Dr.M.Ramakrishnan, V.D.Ashok Kumar And Dr.S.Malathi (2015) .Performance Improvement Using An Automation System For Recognition Of Multiple Parametric Features Based On Human Footprint. For The International Journal Of Kuwait Journal Of Science & Engineering, Vol 42, No 1 (2015), Pp:109-132.
- [9] V.D.Ambeth Kumar, V.D.Ashok Kumar, S.Malathi, K.Vengatesan, M.Ramakrishnan. Facial Recognition System For Suspect Identification Using A Surveillance Camera.Pattern Recognition And Image Analysis (Springer), Volume 28, Issue 3, Pp 410-420, 2018. (Doi: 10.1134/S1054661818030136)
- [10] V.D.Ambeth Kumar And M.Ramakrishan, "Employment Of Footprint Recognition System", In The Month Of December For Indian Journal Of Computer Science And Engineering (Ijcse) Vol. 3 No.6 Dec 2013
- [11] Ramya,T.,Dr.Malathi,S.,Ratheeksha,G.R. And Dr.V.D.Ambeth Kumar (2014). Personalized Authentication Procedure For Restricted Web Service Access In Mobile Phones. Applications Of Digital Information And Web Technologies (Icadiwt), 2014, Page(S):69 - 74, Bangalore, India (Isbn:978-1-4799-2258-1)
- [12] Ambeth Kumar.V.D (2018). Novel Wireless Sensing System For The Welfare Of Sewer Laborers. Healthcare Technology Letters (Iet) Volume 5, Issue 4, P. 107 –112.
- [13] Ambeth Kumar.V.D, G.Saranya , D.Elangovan, V.Rahulchiranjeevi, V.D.Ashok Kumar."Iot Based Smart Museum Using Wearable Device". Lecture Notes In Networks And Systems, Vol.55, Pp: 33-42, 2018
- [14] Ambeth Kumar.V.D And Dr.M.Ramakrishan,"Footprint Based Recognition System", Communication In Computer And Information System, Volume 147, Part 3, 358-367, Doi: 10.1007/978-3-642-20573-6\_63, April 2011
- [15] Ambeth Kumar.V.D (2017).Efficient Routing For Low Rate Wireless Network A Novel Approach. International Journal Of Image Mining, Vol. 2, Nos. 3/4, 2017, 2017
- [16] Ambeth Kumar.V.D, V.D.Ashok Kumar, Dr.S.MalathiAndP.Jagaeedesh, (2014) .Intruder Identification Using Footprint Recognition With Pca And Svm Classifiers. For The International Journal Of Advanced Materials Research Vols.1345, Pp 984-985 (2014) Pp 1345-1349. [Doi:10.4028/Www.Scientific.Net/Amr.984-985.1345]
- [17] B. Aravindh; V.D.Ambeth Kumar; G. Harish; V. Siddarth, " A novel graphical authentication system for secure banking systems", IEEE (ICSTM), Pages: 177 – 183, 2-4 Aug. 2017, DOI: 10.1109/ICSTM.2017.8089147.
- [18] R. Subha Shini et.al., " Recurrent Neural Network based Text Summarization Techniques by Word Sequence Generation",IEEE International Conference on Inventive Computation Technologies (ICICT), 2021, DOI: 10.1109/ICICT50816.2021.9358764



# Efficient Diagnosing Method for Heart Disease Using Deep Learning

Jayanthi S<sup>a,1</sup>, Hajara FathimaS<sup>b</sup>, IndiraniG<sup>c</sup>, Dr.C.R.ReneRobin<sup>d</sup>

<sup>a</sup>Assistant Professor, Dept of CSE, Agni College of Technology, Chennai

<sup>b,c</sup>UG Student, Dept of CSE, Agni College of Technology, Chennai

<sup>d</sup>Professor, Dept of CSE, Sri Sairam Engineering College, Chennai

**Abstract.** Heart Disease(HD) is one of the most serious health issue that attacks people age from 65 and older and has symptoms are palpitations , loss of conscious ,abnormal heart beats and it also can attack younger people who has going through lots of stress, over weight and chest pain and so on. Diagnosing heart disease manually is less efficient and mostly not accurate. Machine Learning (ML) helps efficiently in early prediction of Heart Attack. In this paper we have used LSTM (Long Short Term Memory) a Deep Learning Technique to diagnose heart attack. Diagnosing is complicated as it is important task, it needs to be executed accurately and efficiently. This system helps in prediction of HD which used the supervised learning that has low computation.

**Keywords.** LSTM, Neural network, Heart disease Prediction.

## 1. Introduction

Heart disease is rising around worldwide. In earlier days, the older people only get heart disease but now a days even young teenagers also get affected by heart attack ,For example, In U.S more children getting affected by Heart Disease which includes congenital heart disease, Arrhythmias to prevent this we have to predict the disease in early stages Incidence of heart disease is set to rise, with an aging global population. The heart disease increasing in adults as well as youngsters which leads to aim of better prevention and treatment of heart disease. We build the system which gives suggestions for common treatment for heart attack. Heart disease can also be prevented by food control, stress control. For example, Foods like Leafy green vegetables, whole grains, Avocados, Walnuts, etc., This paper deals with segment I describes introduction , segment II describes related work, segment III presents methodology, segment IV describes module description, segment V deals with analysis and segment VI gives conclusion and future work and finally, the reference.

---

<sup>1</sup>Jayanthi S, Assistant Professor, Dept of CSE, Agni College of Technology, Chennai, India.  
Email:jayanthi.cse.act@edu.in<sup>1</sup>

## 2. Related Work

R.Miclo et al. (2015) Real time location system based process mining uses process mining tool that automatically saves the actions in accordance to patients locations in the service. The process mining model does not provide accurate, detailed enough for upcoming research. It has drawbacks that consumes lot of time and may cause interpretations. Min Chen et al.(2017) have demonstrated Disease Prediction by Machine Learning over big data from HealthCare Communities, explain how to use big data in disease prediction. Big data helps ito accurate prediction of disease with patient system is level of accuracy is decreasing when medical data is incomplete and has no voice pathology information. Syed Umar Amin et al. (2019) have demonstrated Cognitive Smart Healthcare for pathology Detection and Monitoring they propose a cognitive healthcare model that combines IOT-cloud technologies for pathology detection and classification. This method have 87% accuracy, we need to increase efficiency by adding new deep learning technique. This system helps to provide high quality health care in real-time and it using sensor readings that allows to find patient state. Anand Sharma et al. (2014) have demonstrated Emerging Application of Data Mining for Healthcare Management , has higher quality of health care, high performance, low-support, low-confidence, they showed a difficult review of the different research. They built system which provide quality healthcare resource management and helps to diagnosis and treatment of various disease. Arianna Dagliati et al.( 2014) have illustrate the technique to identify cardiovascular disease related to multidisciplinary tool to manage patient clinical course .The main goal of their work is to derive health care pathways .It also allows to gain understanding T2D patients care.

## 3. Methodology

In the proposed system, we choose LSTM among various algorithm. LSTM is a deep learning technique which helps to overcome data loss while predicting time series data , as it provides a best solution to vanishing and exploding gradients compare to RNN. It gives effective result in many relevant application like heart disease prediction. This helps to retain the information without loss as it used to accurate prediction of disease.

## 4. Module Description

### *Module 1 : Exploratory Data Evaluation*

It gives depth understanding of dataset which helps to find the clear view of data .It allows us to use visual and quantitative techniques to determine trends, structure etc. Before making any presumption EDA main purpose to find the pattern of data. It helps to searching and finding out missing data and other mistakes such as errors, anomalies. For example, EDA tool used to create an EDA are python and R language.

### *Module 2 : Pre-processing*

Scikit Learn preprocessing is a python library which allows to do preprocessing for given dataset. Preprocessing is a term basically means to discover the some lost data in

the dataset. It is essential to do this process as it have chance to loss the important information that in need to determine heart disease without any delay. We should convert the categorical data into numerical which is the only way for mathematical algorithmic model to understand the data set variables. Since it is quite difficult for machine to process text . In preprocessing it is a important part to split dataset in to two sets called training set and testing set. The python library scikit used to split the dataset according to certain percentage is test\_train\_split from model\_selection.

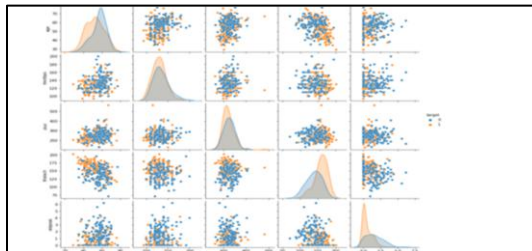
*Module 3 : Feature Engineering*

Feature selection is independent of any machine learning algorithms. It helps more to decrease computational cost by eliminate the less important input variable. Feature is the term represents the column also called variable, feature selection usually based on dependency between the variable, the features of dataset is selected to gives as input to get efficient output. Based on correlation co-efficient that is between -1 to +1 we can have other following method to select feature there are, LDA, Fisher’s score and so on.

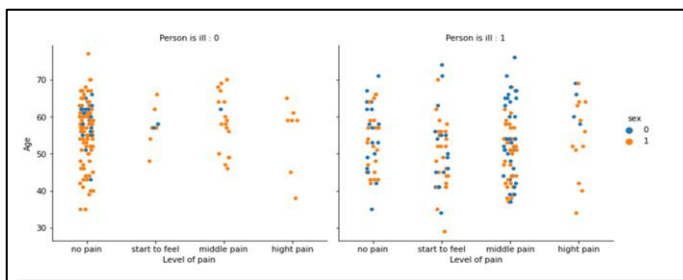
*Module 4 : Prediction*

Prediction can be done by evaluating the model by giving testing dataset which helps to find whether the model is trained well or not. Based on accuracy and speed of the model we can decide. As the splitting of dataset mainly relays on the how large or small the dataset. After the evaluation process is complete , we can test by giving other values.

**5. Analysis**



**Figure 1.** Distribution of highly correlated features over Target variable.



**Figure 2.** Distribution of ill and not ill person based on Sex ,Age and Level of pain.

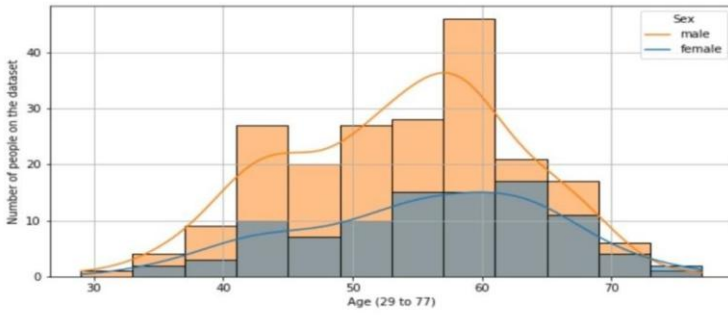


Figure 3. The above histplot represent the number of male and female in between age 29 to 77 in the total number of people on the dataset

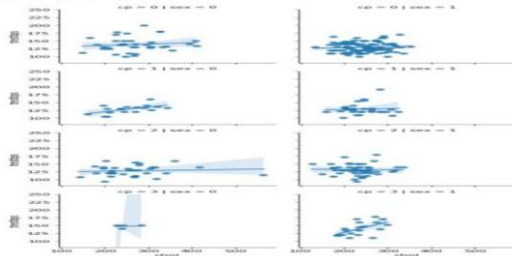


Figure 4. The scatter plot defines relation between trestbps and cholesterol for each type of chest pain and sex.

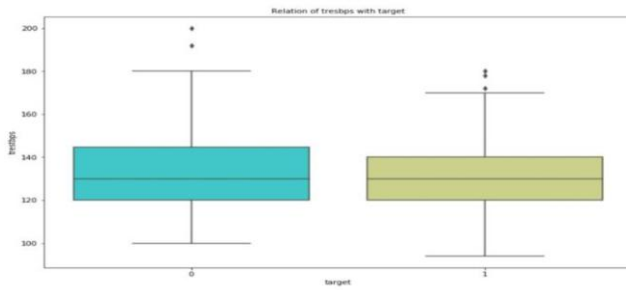
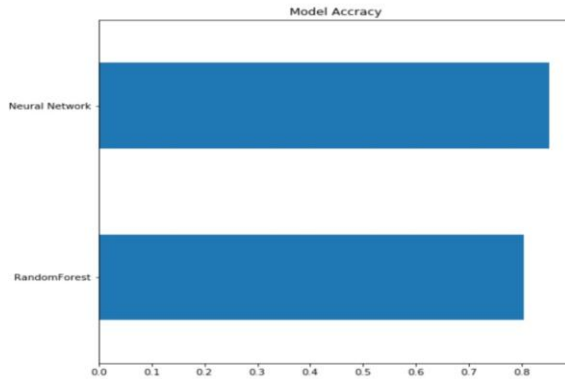


Figure 5. The box plot graph represents between the trestbps and target.



**Figure 6.** Diagram shows the comparison of Model accuracy between neural network and Random forest, which gives neural network with high accuracy.

## 6. Conclusion

We have developed algorithm with high accuracy which also helps to prevent from missing information. Though it can process well in easily obtainable clinical data. It provides low computation power. In future work will include real-time information for dietary plans and treatment suggestion based on the stages of heart attack. Another future line would be detection of various heart related disease.

## References

- [1] M. Durairaj and N. Ramasamy, A comparison of the perceptive approaches for preprocessing the data set for predicting fertility success rate, *Int. J. Control Theory Appl.*, vol. 9, no. 27, pp. 255\_260, 2016.
- [2] Allen.L.A, L.W. Stevenson, K. L. Grady, N. E. Goldstein, D. D. Matlock, R. M. Arnold, N. R. Cook, G. M. Felker, G. S. Francis, P. J. Hauptman, E. P. Havranek, H. M. Krumholz, D. Mancini, B. Riegel, and J. A. Spertus, Decision making in advanced heart failure: A scienti\_cstatementfrom the American heart association, *Circulation*, vol. 125, no. 15, pp. 1928\_1952, 2012.
- [3] Ghwanmeh.S, A. Mohammad, and A. Al-Ibrahim, Innovative arti\_cial neural networks-based decision support system for heart diseases diagnosis, *J. Intell. Learn. Syst. Appl.*, vol. 5, no. 3, 2013, Art. no. 35396.
- [4] Lopez-Sendon.J. The heart failure epidemic, *Medicographia*, vol. 33,no. 4, pp. 363\_369, 2011.
- [5] P. A. Heidenreich, J. G. Trogdon, O. A. Khavjou, J. Butler, K. Dracup, M. D. Ezekowitz, E. A. Finkelstein, Y. Hong, S. C. Johnston, A. Khera, D. M. Lloyd-Jones, S. A. Nelson, G. Nichol, D. Orenstein, P.W. F. Wilson, and Y. J. Woo, Forecasting the future of cardiovascular disease in the united states: A policy statement from the American heart association, *Circulation*, vol. 123, no. 8, pp. 933\_944, 2011.
- [6] A. Tsanas, M. A. Little, P. E. McSharry, and L. O. Ramig, Nonlinearspeech analysis algorithms mapped to a standard metric achieve clinicallyusefulquanti\_cation of average Parkinson's disease symptom severity, *J. Roy. Soc. Interface*, vol. 8, no. 59, pp. 842\_855, 2011.
- [7] S. Nazir, S. Shahzad, S. Mahfooz, and M. Nazir, Fuzzy logic based decision support system for component security evaluation, *Int. Arab J. Inf. Technol.*, vol. 15, no. 2, pp. 224\_231, 2018.

- [8] R. Detrano, A. Janosi, W. Steinbrunn, M. P. Sterer, J.-J. Schmid, S. Sandhu, K. H. Guppy, S. Lee, and V. Froelicher, International application of a new probability algorithm for the diagnosis of coronary artery disease, *Amer. J. Cardiol.*, vol. 64, no. 5, pp. 304\_310, Aug. 1989.
- [9] Y. Li, T. Li, and H. Liu, Recent advances in feature selection and its applications, *Knowl. Inf. Syst.*, vol. 53, no. 3, pp. 551\_577, Dec. 2017.
- [10] J. Li and H. Liu, Challenges of feature selection for big data analytics, *IEEE Intell. Syst.*, vol. 32, no. 2, pp. 9\_15, Mar. 2017.
- [11] L. Zhu, J. Shen, L. Xie, and Z. Cheng, Unsupervised topic hypergraph hashing for efficient mobile image retrieval, *IEEE Trans. Cybern.*, vol. 47, no. 11, pp. 3941\_3954, Nov. 2017.
- [12] Raschka, Model evaluation, model selection, and algorithm selection in machine learning, 2018, arXiv:1811.12808. [Online]. Available: <http://arxiv.org/abs/1811.12808>
- [13] Palaniappan and R. Awang, Intelligent heart disease prediction system using data mining techniques, in *Proc. IEEE/ACS Int. Conf. Comput. Syst. Appl.*, Mar. 2008, pp. 108\_115.
- [14] E. O. Olaniyi, O. K. Oyedotun, and K. Adnan, Heart diseases diagnosis using neural networks arbitration, *Int. J. Intell. Syst. Appl.*, vol. 7, no. 12, p. 72, 2015.
- [15] Das, I. Turkoglu, and A. Sengur, Effective diagnosis of heart disease through neural networks ensembles, *Expert Syst. Appl.*, vol. 36, no. 4, pp. 7675\_7680, May 2009.
- [16] O. W. Samuel, G. M. Asogbon, A. K. Sangaiah, P. Fang, and G. Li, An integrated decision support system based on ANN and Fuzzy\_AHP for heart failure risk prediction, *Expert Syst. Appl.*, vol. 68, pp. 163\_172, Feb. 2017.
- [17] S. I. Ansarullah and P. Kumar, A systematic literature review on cardiovascular disorder identification using knowledge mining and machine learning method, *Int. J. Recent Technol. Eng.*, vol. 7, no. 6S, pp. 1009\_1015, 2019.
- [18] S.Hema Kumar, J.UdayKiran, V.D.AKumar, G.Saranya, Ramalakshmi V. Effective Online Medical Appointment System. *International Journal of Scientific & Technology Research*, Volume 8, Issue 09, September 2019, Pages 803 – 805.
- [19] V.D.Ambeth Kumar, G.Gokul, S.Malathi, K.Vengatesan, D.Elangovan, B.Chitra. Implementation Of The Pulse Rhythmic Rate For The Efficient Diagonising Of The Heart Beat. *Healthcare Technology Letters (IET)* 2019 Apr 17;6(2):48-52.
- [20] S.V. Ruphitha et.al. Management of Major Postpartum Haemorrhage by using Zigbee protocol - A Review . 2021 6th International Conference on Inventive Computation Technologies (ICICT) (DOI: 10.1109/ICICT50816.2021.9358757 )
- [21] Ambeth Kumar.V.D, Dr.M.Ramakrishnan, V.D.Ashok Kumar and Dr.S.Malathi (2015) . Performance Improvement using an Automation System for Recognition of Multiple Parametric Features based on Human Footprint. *kuwait journal of science*, Vol 42, No 1 (2015), pp:109-132.
- [22] Ramakrishan.M et.al..Footprint Based Recognition System. in the month of April for the International Journal Communication in Computer and Information System (CCIS) Journal (Springer) Volume 147, Part 3, 358-367, DOI: 10.1007/978-3-642-20573-6\_63, April 2011
- [23] Ramya,T., .Malathi,S.,ratheeksha,G.R. and V.D.Ambeth Kumar (2014).Personalized authentication procedure for restricted web service access in mobile phones. *Applications of Digital Information and Web Technologies (ICADIWT)*, 2014, Page(s):69 - 74, Bangalore, India (ISBN:978-1-4799-2258-1)
- [24] Indhumathi.M et.al .Healthcare Management of Major Cardiovascular Disease-A review.2021 6th International Conference on Inventive Computation Technologies (ICICT), (DOI: 10.1109/ICICT50816.2021.9358519 )
- [25] Ambeth Kumar.V.D (2018). Novel Wireless Sensing System For The Welfare Of Sewer Laborers.*Healthcare Technology Letters (IET)* Volume 5, Issue 4, p. 107 –112.

# Anxiety Controlling Wrist Band

Shruthi S<sup>a</sup>, Priya dharshini<sup>b</sup>, Ranjith Raj B<sup>c</sup>, Vaddi Lakshmi Satya Sai Sarojini<sup>d</sup>  
Ezhilarasi P<sup>e</sup>, Rajesh Kannan S<sup>f</sup>

<sup>a</sup>UG Scholar, Dept of ECE, St. Joseph's College of Engineering, Chennai, India

<sup>b</sup>UG Scholar, Dept of ECE, St. Joseph's College of Engineering, Chennai, India

<sup>c</sup>UG Scholar, Dept of ECE, St. Joseph's College of Engineering, Chennai, India

<sup>d</sup>UG Scholar, Dept of ECE, St. Joseph's College of Engineering, Chennai, India

<sup>e</sup>Associate professor, Dept of ECE, St. Joseph's College of Engineering, Chennai, India

<sup>f</sup>Associate professor, Dept of ECE, St. Joseph's College of Engineering, Chennai, India

**Abstract.** Since the 1950s, suicide rate has been tripled among people aged between 15 and 24. Also, suicide is reported as the second most common cause of their deaths. Depression and anxiety are one of the major reasons for planting the thought of suicide in students' mind. People with anxiety disorders and stressful mind have excessive worry and fear about everyday situations. This intense worry and fear, though appears harmless, can reach its peak within minutes causing panic attacks. The main objective of our project is calming down the mind of people who are emotionally unstable and preventing the occurrence of any medical complications due to anxiety. Our innovation focuses on measuring the heart rate and controlling perturbation, anxiety, stress by applying acupressure at the H7 (Heart 7) point on the wrist crease.

**Keywords.** Anxiety; Stress; H7; Acupressure; healthcare; heartrate monitor; health tracking device; wrist band; COVID-19.

## 1. Introduction

Anxiety is a condition in which a person feels uneasy or nervous for an uncertain outcome. It is often caused by stress or trauma. Earlier it was considered to be a mental disorder but now it is common among many individuals. According to recent statistics over 40% of adult population is suffering from anxiety in USA. Acupressure is one of the ways to reduce anxiety. Anxiety controlling wrist band <sup>[1]</sup> is one such device that measures our heart rate and automatically triggers pressure in pressure point on the wrist. This calms the people wearing it. It is also connected to a mobile application through Bluetooth. It gives you notification when your heart beat goes high. It also contains an oximeter that measures oxygen content in blood.

## 2. Related Survey

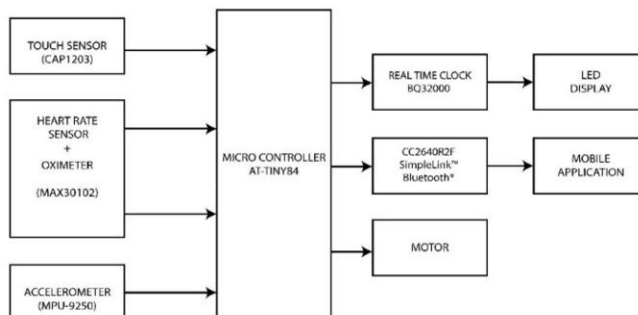
Heart rate is the primary parameter based on which the dysregulated emotions are monitored and tracked. Though there are a lot of devices used in monitoring these were

---

emotions, controlling of these emotions with external devices is restricted. One of the effective and ancient methods of controlling these emotions manually is by stimulating certain part of the body for the respective function. In some of the existing models, a nausea control device which can be attached to the human wrist is described. Some devices use non-invasive nerve stimulation by passing electricity through two electrodes to stimulate the nerves. Another technique is to apply pressure to the acupuncture area either with the fingers or using a small rounded instrument (acupressure). Mobile devices for stimulation of certain acupuncture point are existing and are available for use. For example, the Sea Band (Sea-Band UK Ltd., USA) acupressure device is used for the treatment of nausea which stimulates the acupuncture point P6 and is specially designed for sea travellers. Other devices with similar application were also proposed, for example, Griffith, U.S. Pat. No. D274,557 [2], Giarratano, U.S. Pat. No. 5,078,728 [3], Humphrey, U.S. Pat. No. D356,433 [4], Yoo (U.S. Pat. No. 5,774,424) [5] describes an acupressure stimulator consisting of a pressure plate with nodules. In those methods, stimulation is done by giving pressure constantly. Scientific research have indicated that constant pressure for stimulation can be effective but it is not consistent and reduces over time, resulting in short-term benefits ultimately leading to the reappearance of the undesirable symptoms. Jacobs (U.S. Pat. No. 4,574,787) [6] describes a device where a fluid vibrates and the vibration results in changing pressure. But it has the risk of liquid leaking and requires a separate vibration source. Fisher (U.S. Pat. No. 5,601,598) [7] describes a method where the user has to periodically stretch the band to create changing pressure which is reported to be inconvenient by the users. Strumor (U.S. Pat. No. 5,607,749) [8] describes a similar system to that of Jacob's where air is used instead of the fluid and the movement causes differential pressure. While these methods have some functionality, they need either bulky equipment or active user participation that limits the usage of the product. In some cases, patients need extended periods of treatment, and the current devices are inconvenient because they require constant operator action or immobility. Since it is required to treat these emotions during normal activities and instantly, without the user's attention, this band is prescribed.

### 3. Proposed Methodology

The Figure 1 gives the block diagram of the proposed anxiety reduction model.



**Figure 1** Block diagram of Proposed Anxiety Controlling Model

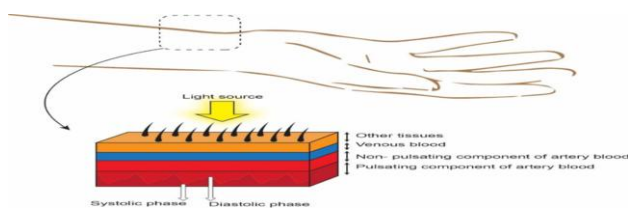


The heart of the system is AT-TINY84 microcontroller which interfaces sensors [9] and the outputs. The inputs to AT-TINY84 are given by the sensors, touch sensor, heart rate sensor, oximeter and accelerometer. MAX30102 is an integrated device that contains both pulse oximetry and heart-rate monitor. MPU-9250 is a 9-axis Motion Tracking device that combines a 3-axis gyroscope, 3-axis accelerometer, 3-axis magnetometer and a Digital Motion Processor all in a small package. Based on the inputs given to the controller, the clock, Bluetooth module and the motor of the acupressure system operates. The BQ32000 is the real time clock that displays time. CC2640R2F is the Bluetooth module which transmits the input data to the application. The motor drives the cam action of acupressure system.

### 3.1 Sensors

#### 3.1.1 Heart rate sensor and oximeter

MAX30102 is an integrated device that contains both pulse oximetry and heart-rate monitoring sensor. It requires a low power supply of 1.8V. A standard I2C-compatible interface is used for communication. This methodology used by MAX30102 to measure the heart rate is called Photoplethysmography where light is incident in the skin and based on the reflection of the incident light, the measurements are made. One of the practical aspects of this approach is the possibility of differentiating the light reflected by the blood of an artery (produces an AC output) and other components of the body such as bones and tissues (produces a DC output). The sensor consists of a photo-diode that helps to convert the light to current which can be used as comprehensible data. In the device the MAX30102 sensor is installed as shown in Figure 2 thereby enabling the light source pass through the tissues to collect information about the heart rate and oxygen saturation. These values are then displayed to the user by connecting the device with a mobile application.



**Figure 2.** Light source pass through the tissues to collect information about the heart rate and oxygen saturation

#### 3.1.2 Touch sensor CAPI302

Capacitive touch sensors are used in most of the portable devices like mobile phones and MP3 players. The dimension of CAPI302 is 2 x 3 mm. The CAPI203 includes Touch recognition which when detected, a status bit is set and an interrupt is generated. It comes with Active and Standby states, each with its own sensor input configuration controls. Power consumption in the Standby state varies depending on the enabled number of sensor inputs and number of outputs generated. The device communicates

with a host controller using SMBus / I2C. Cap1302 features multiple pattern touch recognition that can sense touch simultaneously. If the pattern is observed, then the status bit is set and an interrupt is generated. The role of this sensor in the device is to make sure that the device is mounted firmly on the wrist. If the wristband is worn loosely, the acupressure setup will not be held firmly against the H7 point. Therefore, the switching ON of the whole acupressure system depends on the input from the CAP1302 sensor.

### 3.1.3 Accelerometer, gyroscope, magnetometer

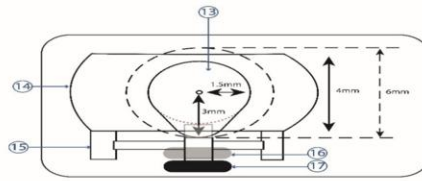
MPU-9250 <sup>[10]</sup> is a multichip module which has a 3-Axis gyroscope, 3-Axis magnetometer and a 3-Axis accelerometer. The role of MPU-9250 in this device is the same as in the fitness bands. This sensor tracks the movement and orientation of the device thereby deriving the step count and the distance covered. It is also useful in tracking the rotation of the system. The LED display of the device displays the time when the device is found to be rotated. Therefore, the working of the LED display depends on the input from the MPU-9250. Apart from the above function, the major contribution of MPU-9250 in the device is to determine if the person is idle or not. The Acupressure system starts when the heart rate of the person is detected to be high. But, the increase in heart rate due to exercising, running and other physical activities should not trigger the acupressure system. The accelerometer serves this purpose of not switching ON the acupressure system unless the person is idle, even though the heart rate is rising beyond the normal limit.

### 3.2 Acupressure

The device of the present invention has a tiny DC motor **13** used to rotate the cam **16** across an acupressure nodule. The motor rotates with a speed 20 rpm such that pressure is applied every 3 seconds. The motor starts rotating when the heart rate is found to be increased by the sensor and provides acupressure on the H7 acupuncture point **6** in order to treat anxiety. The cam will be in contact with the skin in the H7 acupuncture point **6** as shown in Fig 3. The microcontroller controls the motor **13** for this nodule. The cam will stimulate the H7 or Heart 7 acupuncture point when it is programmed to. It is programmed such a way that the motor stays idle normally and starts its operation only when the heart rate input to the microcontroller is abnormally high. The power supply for this motor is provided by the rechargeable battery. The conversion of rotational movement into linear movement, defined as the operation of cam is an application of the electromechanical principle. The whole acupressure setup is placed in the bottom layer of the device. A flexible sheet **10** seals the components against water, dust, etc. The compact dimension of the motor used (11×4×4 mm) and the dimension of cam being 1.5×2×1.5 mm helps the acupressure system to be occupied within the wearable device. The wrist point location and cam setup has been illustrated in Figure 3 & 4



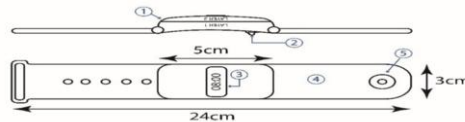
**Figure 3.** Location of the H7 or Heart 7 point on the wrist



**Figure 4.** Acupressure system with cam setup

### 3.3 Design

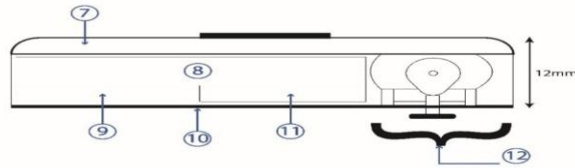
The wrist band has a total length of 240mm as illustrated in Figure 5. The main casing 1 is of the dimension of 10×50×30 mm. The strap of the device is made using silicon while the curve-edged main case 1 is made up of hard plastic. The digital display 3 of the watch is at the center of the case, having the dimension of 10×30 mm displaying the time in 24 hours clock-time.



**Figure 5.** Vertical and Horizontal cross section of whole system

The lower layer of the device <sup>[11]</sup> has the fabricated circuit containing a heart rate and pulse oximeter sensor 9, a touch sensor 11 occupying the left and center portion of the lower layer while the acupressure system 12 having a motor and cam occupies the rightmost of the base layer. The surface area of heart rate and pulse oximeter sensor is made substantial compared with other sensors so as to enhance the detection of pulse for various wrist sizes. The touch sensor 11 in the base layer is used to detect if the device is worn precisely. There are three different sizes available for the device: small, medium and large for different wrist sizes. Also, it comes with an instruction manual such that the watch must be worn in a specific region of wrist, making sure that the acupressure system 12 is focused on the H7 point 6. The nodule 2 is not directly contacted with the skin and a flexible sheet 10 is used to cover the base of the nodule 2 in order to be sealed against water, dust, etc. This sheet 10 also serves the purpose of not causing any irritation or itchiness on the skin. The middle layer 8 of the device contains a rechargeable battery and a controller while the upper layer 7 of the main case has the accelerometer, LCD display 3 and a Bluetooth circuit. The controller controls the working of the motor 13 for acupressure system 12, the digital display 3 and the Bluetooth transmitter based on the inputs received by the touch, heart rate, pulse oximeter and the accelerometer. The function <sup>[12]</sup> of the sensors and the controller is the same as that of a normal fitness band, which displays time, heartrate, step count, distance travelled and also which turns on when the gyroscope detects rotation or movement of the hand and connecting with an application in the mobile phone. The importance of accelerometer is that it helps in not raising an alarm message when the

heart rate is increased during physical activities such as exercise, running, etc. The whole system has been illustrated in Fig 6. The enhancements made in this device includes the acupressure system **12** that provides with a reaction or solution to anxiety and nervousness and the pulse oximeter readings which helps to diagnose diseases like COVID-19.



**Figure 6.** Vertical cross section of the system assembly

### 3.4 Mobile Application

For visualizing the sensor feeds, their values have to be updated to a User-Interface. The device uses Bluetooth MCU <sup>[13]</sup> to send live sensor feeds to server which can be accessed through the mobile application. We have used Bluetooth low energy that is favourable considering the following features,

- Increased performance accuracy
- Compact system
- Covers Long Range (LE Coded PHYs) of 750m at High Speed (LE 2-Mbit PHY)
- Provides Longer battery life for the wireless applications
- Easy-to-use development environment
- Reduced cost

A mobile application is built using MIT application builder to visualize sensor measurements sent from our wearable device through Bluetooth. It allows communication between the device running the app and remote devices. The app is designed in such a way that it is easy to interact with people of all ages <sup>[14]</sup>. It also saves the records regularly in a remote database for offline processing. Anxiety can be caused due to many occasions i.e., shocks, stage fright etc. It causes abnormal heart rhythms that might go above 100 beats per minute which might cause serious health issues. So, it is necessary to monitor heart rates.

Our app continuously monitors the heart rate and gives alert notifications on abnormal heart rates. The world has been under threat due to the wide spread of Corona virus (COVID-19). Doctors have found a way to detect the virus using the oxygen saturation level in the blood of a person. The oximeter plays a crucial role in monitoring the oxygen levels and lets an individual know about the dropping levels. If the oxygen saturation content drops to 90% or below, those people are said to be affected by the Corona virus. Our device monitors the oxygen saturation levels and sends feeds to the app. An alert is sent to the users who are prone to COVID-19. In conclusion, typical features of the mobile application are,

- Oxygen saturation levels alert system
- Tracking water content and sleep

- Heart rate and Oxygen level monitoring
- Available at different languages

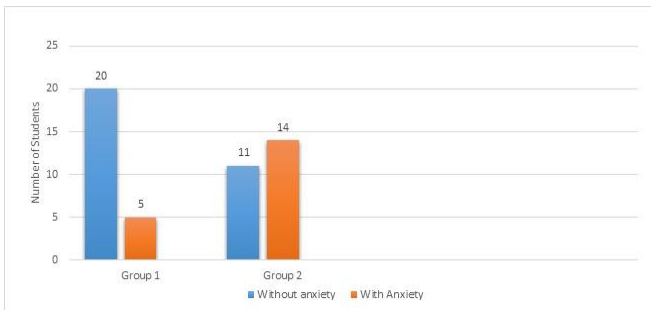
### 3.5 Results And Discussion

Fifty students were enrolled in this study. Twenty-five students were given our prototype of anxiety controlling wrist band shown in Figure 7 (Group 1) whereas others were given normal wrist bands similar to Fitbit (Group 2). The students were given tasks to speak or perform on the dais facing other students. All the features were akin in both groups given in Table 1 except the weights in the Group 2 that were slightly more than the Group 1.

**Table 1.** Various Categories of students for experimentation

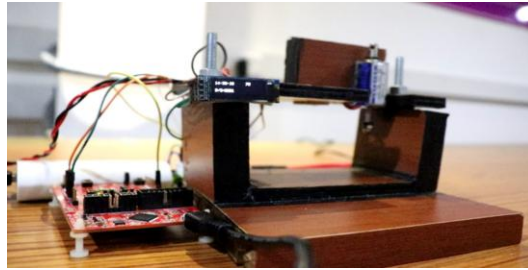
Categories	Acupressure wrist band Group (Group 1)	Normal wrist band Group (Group 2)
Age (Years)	19 ± 2	19 ± 2
Gender (M/F)	10/15	12/13
Height (cm)	151 ± 5	157 ± 3
Weight (Kg)	60 ± 5	62 ± 5

The students were made to wear our prototype on a daily basis which helped us to differentiate between health conditions of the two groups. After experimenting over two-month period, a significant change was seen in Group 1 than in Group 2. The former was able to express themselves in-front of large crowds without having any anxiety or stage fright. Also, they were able to communicate with strangers efficiently. Whereas the latter still had difficulty in expressing themselves and often developed nausea due to nervousness (anxiety) [15]. Though the Group 2 was able to track and monitor these emotions, they were not able to overcome it. It can be illustrated from Fig 8 that the number of students with acupressure wristband showed improved health conditions.



**Figure 7** Anxiety level comparison chart of Normal fitbit and Proposed Prototype users

Acupressure is similar to acupuncture [16] but without needles. It is based on the pathways of energy flow within the body called as meridians (traditional Chinese medicine). There are at least 14 meridian points connecting different organs. It is mostly used to manage symptoms of health complications (such as cancer, insomnia, headache, menstrual cramps and stress management). Some of the accupoints [17] are, P6 point primarily used to treat nausea & vomiting and H7 point is used for relaxing the body from various health issues such as panic attacks and stress. This point is located at the radial side of flexor carpi ulnaris (at the end of the palm).



**Figure 8.** Automatic Prototype Acupressure Model

C1 Huatuo point is present at the top of the head and is an important juncture between brain and body. It is mostly used within Tam Healing system and Tong Ren Therapy. The user friendly application plays a major role for the device and various languages are available that can be modified based on users choice.



**Figure 9.** Activity log in App



**Figure 10.** Application Dashboard

The dashboard or main page of our app is shown in Figure 10. Heart rate and SpO<sub>2</sub> measurements are displayed in gauges with its measurements in bpm and percentages. If abnormal heart rate measurements are received, then alert message will be sent to the mobile phone through the app. Similarly, if SpO<sub>2</sub> measurements are abnormal, alerts will be generated and will be directed to contact a doctor. Figure 9 is referred as the Activity log or workout log page. It consists of different workout challenge that differ from person to person depending upon their weight and height which must be provided as an initial requirement to the app.

For every hour from 9 A.M. to 9 P.M., we obtained heart rate measurements from a student while presenting a seminar and plotted the values in the form of a 2-D Area Chart with Time in hours along X axis and heart rate in beats per minute along Y axis shown in Figure 11.

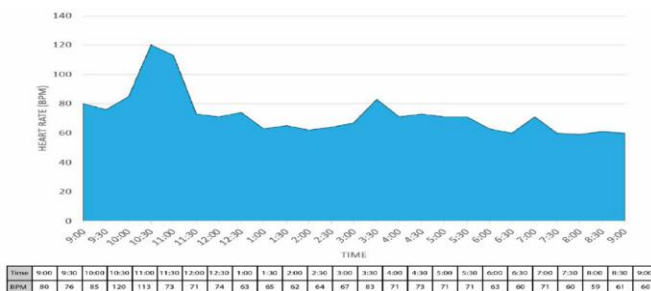


Figure 11. Heart rate measurements over a period of 12 hours

#### 4. Conclusion

Many thought that the Asian method of acupressure as a suspicion earlier. However, we have demonstrated that it is a genuine method to prevent insomnia, anxiety, nausea and vomiting. The main objective of controlling anxiety is achieved by activating various acupressure points. Thus, anxiety-controlling wristband which makes use of the traditional method, is proved to be beneficial to assuage health and emotional illness through the course of experiments conducted on people suffering from anxiety.

#### References

- [1] Mohamed Elgendi and Carlo Menon, “Assessing Anxiety Disorders Using Wearable Devices: Challenges and Future Directions”, *Journal of Brain Science*, 9(3), pp.50, March 2019
- [2] Richard Griffith, “Wristband for controlling nausea”, United States Patent, 354,132, Des. 274,557, pp. 1-2, Jul. 3, 1984
- [3] Thomas L. Grey, San Marcos, Robert J. Duffy, Poway, Robert C Giarratano, “Device for relief from morning sickness”, United States Patent, 5,078,728, US 2004/0098037 A1, pp. 1-5, Jan. 7, 1992
- [4] Doyce L Humphrey, “Elastic Wrist strap”, United States Patent, 15,828, Des. 356,433, pp. 1-2, Mar. 21, 1995
- [5] Tae Woo Yoo, “Acupressure stimulator for a watch”, United States Patent, 784,571, Des. 5,774,424, pp.1- 4, Jun. 30, 1998
- [6] H Barry Jacobs, “Acupressure apparatus”, United States Patent, 408,003, 4,574,787, pp. 1-5, Mar. 11, 1986
- [7] Gary R Fisher, “Treatment device to aid in long-term cessation of smoking”, United States Patent, 287,209, 5,601,598, pp. 1-17, Feb. 11, 1997
- [8] Mathew A Strumor, “Ergonomic kinetic acupressure massaging system”, United States Patent, 635,407, 5,607,749, pp. 1-13, Mar. 4, 1997
- [9] Lee S.P., Haubrich N.R., Branche P.C., Li W, “Highly flexible, wearable, and disposable cardiac biosensors for remote and ambulatory monitoring”, 31304288, PMC6550217, Jan 25 2018
- [10] Inventions, “MPU-9250 Product Specification”, PS-MPU-9250A-01, version 1.1, pp. 1-42, June. 20, 2016
- [11] John G. Webster, “Medical Instrumentation Application and Design”, 3rd Edition, Wiley India Edition, 2007
- [12] L. E. Bertolucci, “Nausea Control Device”, United States Patent, 4,981,146, pp. 1-2, Jan. 1, 1991
- [13] Texas Instruments, “32-bit Arm Cortex-M3 Bluetooth Low Energy wireless MCU with 128kB Flash and 275kB ROM (CC2640R2F)”, pp. 36-52, revised sept. 2020

- [14] Ting Zhang, Jiang Lu, Fei Hu and Qi Hao, "Bluetooth low energy for wearable sensor-based healthcare systems", 14930130, 2014 IEEE Healthcare Innovation Conference (HIC), Seattle, WA, USA, 8-10 Oct. 2014
- [15] Raghbir Singh Khandpur, "Handbook of Biomedical Instrumentation", 2<sup>nd</sup> edition, TATA Mc Graw-Hill, New Delhi, 2003
- [16] Joseph J.Carr and John M.Brown, "Introduction to Biomedical Equipment Technology", 4<sup>th</sup> edition, John Wiley and Sons, New York, 2004
- [17] Basel Kikhia, Thanos G. Stavropoulos, Stelios Andreadis, Niklas Karvonen, "Utilizing a Wristband Sensor to Measure the Stress Level for People with Dementia", Vol.16, Issue 12, May 2016



# Vehicle License Plate Detection Using Bounding Box Technique

Vanitha N<sup>a,1</sup>, Rene Robin C R<sup>b</sup>, Doreen Hephzibah Miriam D<sup>c</sup>, NSankarGanesh<sup>d</sup>

<sup>a</sup>Research Scholar, Dept of CSE, Sri Sai Ram Engineering College, Chennai, India

<sup>b</sup>Dept of CSE, Sri Sai Ram Engineering College, Chennai, India

<sup>c,d</sup>Dept of CSE, Director of Computational Intelligence Research Foundation, India  
Software Developer, Anandverce, Tamilnadu, India

**Abstract.** The use of vehicles in our daily lives is growing rapidly, and as more vehicles violate traffic laws, theft of vehicles, and a high number of incidents occur, crime rates rise linearly. Vehicle License Plate Detection (VLPD) is an image processing technology for recognizing the vehicle number plate. In a typical VLPD the image of the vehicle is first detected and the vehicle license plate region is captured. Then the filtering techniques are applied to the captured license plate region. In this study bounding box technique is applied for the segmentation and character recognition. It is observed that the created framework effectively detects and recognizes the vehicle number on different test pictures.

**Keywords.** Pre-Processing, Extraction, Segmentation, Recognition and VLPD.

## 1. Introduction

VLPD is required in automated traffic surveillance and vehicle monitoring due to the dramatic increase in the quantity of vehicles. However, with the advancement of digital cameras and the rise in computational capability over the last decade, it has sparked a lot of interest. The purpose of converting a vehicle number plate into a numerically readable character is simple. It can also be used to identify and deter a wide variety of illegal activities, as well as to maintain protection in highly restricted areas. Every vehicle has a unique identification number on its license plate. VLPD is extremely useful in detecting stolen cars, tracking illegal transportation, monitoring gates, speeding, and automatic parking. In order to recognize the vehicle in real time, VLPD must be fast. Despite the fact that there are many methods for identifying vehicle license plates, the performance of a VLPD system is determined by the image quality, which is deteriorated by weather conditions, both static and dynamic. Mist, fog, and cloudiness are instances of static conditions, while downpour and snow are instances of dynamic conditions. Different challenges, like occlusion and shadow, often corrupt the VLPD recognition effectiveness.

---

<sup>1</sup>Vanitha N, Research Scholar, Dept of CSE, Sri Sai Ram Engineering College, Chennai, India.

## 2. Vlpd Challenges

Real time VLPD is extremely difficult due to wide variety of plate design formats. Because of the differences in font size, it is clear that reading alpha numeric letters is difficult. Also, due to the screw fix, the digit '1' may be misread as '7,' and the digit '7' may be misread as '9.'

## 3. Related Works

K. K. Kim et al., [1] deals with VLPD explicitly for Korean plates using Support Vector Machines and has a high normal character acknowledgment rate. Most optical character recognizers carried out in a 2D-plane just keep a high achievement rate only when the shooting distance of the image is less, as indicated by Ko et al., T. Naito et al., [2] [3]. X. Pan et al., [4] proposed a multi-stage recognition scheme that combines statistical and structural recognition approaches, as well as distributing similar characters based on local structural features. Y. Huang et al., [5] used the gradient operator to find the likely number plate location. Parul Shah et al., [6] uses ANN for vehicle chassis number detection. N Vanitha et al., [7] segmented the tropical cyclone eye feature for the classification of cyclone based on the presence and absences of eye [8-13].

## 4. Methodology

There are four main stages to this methodology.

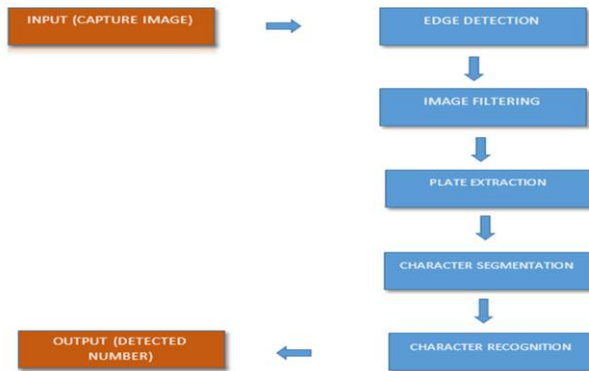
- a. Pre-processing
- b. Extracting
- c. Segmentations
- d. Recognition

a) Pre-processing: The pre-processing stage entails processing the raw image recorded with a digital camera before a particular part of the image is obtained.

b) Extraction: The raw image is converted to gray scale image, by applying various edge detections and threshold to image.

c) Segmentation: Consequently each character on the number plate are segmented using bounding box technique for detection.

d) Recognition: Finally, the procedure is used to equate the extracted image with the real characters in order to recognize the character. Figure 1 shows the block diagram



**Figure 1.**Block Diagram for VLPD

A) Collection of Image: In this analysis, 100 sample images are collected and tested for consistency. Figure 2, shows the input vehicle image with number plate.



**Figure 2.**Collection of Vehicles with Number Plates

B) Pre-processing of Image: The picture, which was originally in RGB colour format, is converted to black and white. It will aid in the identification of the desired vehicle plate region and reduce the number of colours used in the picture. After that, the image is converted with various edge detection techniques, and is followed by the process to extract the number plate very effectively and clearly.

C) Filtering of Image: The black and white images are subjected to the filtering process, after the colour image has been converted to binary. To filter and eliminate noise and distortion from the images, Mexican Hat filtering is chosen.

D) Extraction of Image: The desired features are then extracted from the filtered image using an image extraction of vehicle plate. The cropping process is used in order to execute it. This approach would search for the digital image's black pixel. In this paper, we used the bounding box technique which can be used to place a strong topological prior on the solution, preventing it from shrinking too much and ensuring tightly bounded segmentation.

E) Character Segmentation: Characters, letters, and numbers with a defined font make up the characters on vehicle licence plates. The main phases of character recognition include segmenting the vehicle license plate region, preprocessing, normalizing and using pattern matching for character recognition. Figure 7 illustrates the character recognition of vehicle number plate region with OCR techniques.

## 5. Experimental Results

We have evaluated our method on the dataset of 100 images. Figure 3 shows the input image. Figure 4(a) – (d) illustrates applying filters to the input image.



Figure 3. Input Image



(a)



(b)



(c)



(d)

Figure 4. Applying Filters on image.

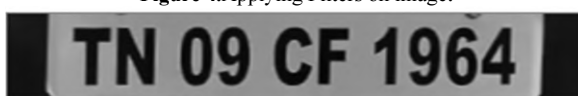


Figure 5. Extracting the vehicle license plate region using Bounding Box



Figure 6. Applying the threshold in extracted plate region



Figure 7. Segmentation using Bounding Box



**Figure 8.**Recognizing the vehicle number

Figure 5 illustrates the vehicle license plate region extraction using Bounding Box technique. Figure 6 shows applying threshold to the extracted region. Figure 7 illustrates the character recognition. Finally figure 8 shows identifying the vehicle number of the input image. The digital image of the vehicle plate was successfully and efficiently processed, with the findings being shown and addressed. The study was run smoothly, and the key goal of developing an automatic vehicle plate detection system was met. Finally, the objective was achieved, and the Vehicle Number Plate was read, which is visible under the license plate region.

## 6. Conclusion

Thus we have investigated the existing frameworks that use license plate recognition systems, we have attempted to resolve system irregularities and achieved substantial results using the methods of various edge detection, threshold, segmentation, and character recognition. Our goal for potential enhancements is to upgrade the application so that it can provide better protection for the general public. Further work is to incorporate all conceivable complex cases of VLPD scenario. The most significant difference is that the state information is considered to be located at the top of the license plate. The majority of VLPDs concentrate on processing a single vehicle number plate, however in real-time, multiple vehicle number plates can be present when the images are being taken. A coarse-to-fine technique could be useful for segmenting multiple vehicle number plates.

## References

- [1] K. Kim, K. I. Kim, J. B. Kim and H. J. Kim, Learning-based approach for license plate recognition, in Proc. IEEE Signal Processing Society, Workshop, Neural Network Signal Process, Dec 2000, vol. 2, pp. 614-623.
- [2] T. Naito, T. Tsukada, K. Yamada, K. Kozuka, and S. Yamamoto, Robust License-Plate Recognition Method for Passing Vehicle Under Outside Environment, IEEE Transaction on Vehicular Technology, Vol. 49, No.6, November 2000, pp. 2309-2319.
- [3] M.A. Ko and Y.M. Kim, License Plate Surveillance System Using Weighted Template Matching, in Proc. of the 32nd Applied Imagery Pattern Recognition Workshop, October 2003, pp. 269-274.
- [4] X. Pan, X. Ye and S. Zhang, A hybrid method for robust car plate character recognition. presented at the IEEE International Conference on Systems, Man and Cybernetics, 2004, pp. 4733-4737.

- [5] Y. Huang, S. Lai and W. Chuang, A Template-Based Model for License Plate Recognition , in The 2004 IEEE International Conference on Networking, Sensing & Control, Taipei,2004,pp. 737-742.
- [6] Parul Shah, Sunil Karamchandani, TaskeenNadkar, Nikita Gulechha, KaushikKoli, Ketan Lad, OCR-based ChassisNumber Recognition using Artificial Neural Networks , presented at the IEEE ICVES 2009, pp. 31-34.
- [7] Vanitha, C R Rene Robin, Segmentation of Tropical Cyclone Eye Using Satellite Infrared Image ,International Journal of Recent Technology and Engineering (IJRTE) , Volume-8, Issue-2S5, pp. 181-185, July 2019.
- [8] Ranya,T.,Dr.Malathi,S.,ratheeksha,G.R. and Dr.V.D.Ambeth Kumar (2014). Personalized authentication procedure for restricted web service access in mobile phones. Applications of Digital Information and Web Technologies (ICADIWT), 2014, Page(s):69 - 74, Bangalore, India (ISBN:978-1-4799-2258-1)
- [9] Ambeth Kumar.V.D (2018). Novel Wireless Sensing System For The Welfare Of Sewer Laborers. Healthcare Technology Letters (IET) Volume 5, Issue 4, p. 107 –112.
- [10] Ambeth Kumar.V.D, G.Saranya , D.Elangovan, V.RahulChiranjeevi, V.D.Ashok Kumar.IOT Based Smart Museum Using Wearable Device.Lecture Notes in Networks and Systems, Vol.55, pp: 33-42, 2018
- [11] S.Hema Kumar, J.UdayKiran, V.D.AKumar, G.Saranya, Ramalakshmi V.Effective Online Medical Appointment System.International Journal of Scientific & Technology Research , Volume 8, Issue 09, September 2019, Pages 803 – 805.
- [12] Ambeth Kumar.V.D, Dr.M.Ramakrishnan, V.D.Ashok Kumar and Dr.S.Malathi (2015) . Performance Improvement using an Automation System for Recognition of Multiple Parametric Features based on Human Footprint.for the International Journal of kuwait journal of science & engineering, Vol 42, No 1 (2015), pp:109-132.
- [13] Ambeth Kumar.V.D, V.D.Ashok Kumar, S.Malathi, K.Vengatesan, M.Ramakrishnan .Facial Recognition System For Suspect Identification Using A Surveillance Camera. Pattern Recognition and Image Analysis (Springer), Volume 28, Issue 3, pp 410–420, 2018. (DOI: 10.1134/S1054661818030136)
- [14] V.D.Ambeth Kumar, , “Precautionary measures for accidents due to mobile phone using IOT”, Clinical eHealth, Volume 1, Issue 1, March 2018, Pages 30-35.
- [15] B. Aravindh; V.D.Ambeth Kumar; G. Harish; V. Siddarth, “ A novel graphical authentication system for secure banking systems”, IEEE (ICSTM), Pages: 177 – 183, 2-4 Aug. 2017, DOI: 10.1109/ICSTM.2017.8089147

# Discriminating Parkinson and Healthy People Using Machine Learning

S. Lakshmi <sup>a,1</sup>, Dr.Manonmani.A<sup>b</sup>, Jagadeeshwaran P<sup>c</sup>AkashS<sup>d</sup>, JananiK<sup>e</sup>, AkilandeswariD<sup>f</sup>

<sup>a</sup>Associate Professor Dept of EIE, Panimalar Engineering College, Chennai, India

<sup>b</sup>Assistant Professor, Dept of EIE, Saveetha Engineering College, Chennai, India

<sup>c,d,e,f</sup>UG Scholar, Dept of EIE, Panimalar Engineering College, Chennai, India

**Abstract.** Parkinson's is a disease which affects at central nervous system of human body and it is popularly known as neuro degenerative disease. we have taken a classification method were mainly focused on speech signal for detection of parkinson's disease because speech is the only deciding factor for earlier stage of the disease identification. Here the ensemble technique is used for classification. Ensemble is method of combining multiple models like classifiers or experts to solve a particular computation .In proposed technique with help of speech signal it is easy to distinguish between diseased and non diseased person. here we are using vowels, number and words from the speech signal in classifiers then how the signal involved in that technique are discussed.

**Keywords.** Parkinson's disease, Neuro degenerative disease, central nervous system, ensembles technique.

## 1. Introduction

Dr. James Parkinson describes parkinson's disease in 1817 as a "shaking palsy." parkinson's is a neurodegenerative disease affects at central nervous system.It affects in motor system of te body. which includes symptoms like bradykinesia, muscular rigidity and resting tremor,. PD is one of the most common neurodegenerative disorders. Risk Factor Associated With Parkinson Disease: Elevated Cholesterol, Increased body mass index and High caloric intake. Diagnosis: diagnosis for parkinson's includes physical examination and comprehensive history of diseased persons. Prediction of Parkinson's disease using speech signal with extreme learning machine[1]. MFCC and SVM are used for analyzing voice prints and detect that patients with Parkinson's disease or not[3]. Assessment of speech intelligibility in Parkinson's disease using a speech-to-text system[5]. Diagnosis of Parkinson's disease using electrovestibulography[6]. Assessment of tremor activity in the Parkinson's disease using a set of wearable sensors[10]. Collection of multiple sound records and analyzing with Parkinson speech dataset .[11]. .Symptoms: • Bradykinesia- Slowness of movement (80% to 90% it occurs) • Rigidity, tremor at rest, Postural instability, Dysarthria, Dystonia, Anxiety, cognitive impairment,, dementia.

<sup>1</sup>Lakshmi.S, Associate Professor Dept of EIE, Panimalar Engineering College, Chennai, India. Email:elzie.moses@gmail.com<sup>1</sup>



## 2. Existing System

In the dataset, it will consider sentence, words, vowels, etc., and also it considers numbers; starts from 0 to 10. Here we have used a different type of method to identify the Parkinson disease. Classifiers are used to differentiate between disease peoples and non- disease people. the feed forward technique, one of the most important of technique for the classification.

Flowchart of Existing System:

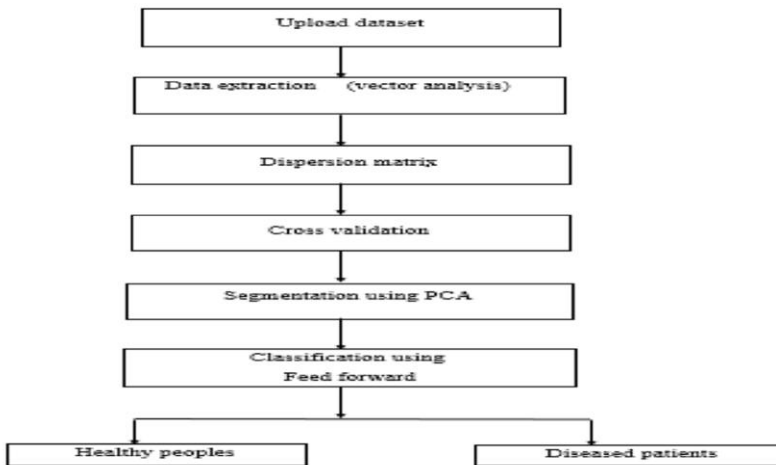


Figure 1. Proposed System

Based on the Speech Signals:

In this experiment we use different types of voice records such as jitter, shimmer, mean pitch, medium pitch and maximum pitch, etc. Consider 26 attributes are generated from the dataset. Jitter percent is also known as jitter factor. Jitter can be calculated using Boken and Orlikff equation,  $[\sum |X_i - X_{i-1}| / (n-1) / [\sum (X_i) / (n)] * 100$ . For the normal waveform of jitter percent is 0.509% and dysphonic waveform of jitter percent is 4.673%. This can be considered as dysphonic waveform is greater than normal wave form. Shimmer is also called amplitude perturbation. It refers the intensity of the amplitude. Shimmer can be calculated using Boken and Orlikff equation i.e.  $[\sum |20 \log (Y_i / Y_{i-1})| / n - 1]$ , For the normal waveform of shimmer is 0.102dB. For the dysphonic waveform of shimmer is 2.005dB. Therefore dysphonic waveform is greater than normal waveform. Quality factor A can be calculated as maximal and minimal sound pressure i.e. amplitude. Outcome of Existing System: This technique works well on the dataset. In 40% non-diseased patients and 60% diseased patients we got a most amazing F measure from the dataset. In the existing system the feed forward technique with the basic concepts of digital image processing leads to a better outcome with more accurate result. A feed forward technique is introduced in existing system.

Drawbacks of Existing System: Accuracy is highly commendable, Binary attribution is only used, Risk of over-fitting the data, Not superior for arithmetic and small calculations, Explanation are not in Neural networks

Problem Identification: In the existing system accuracy using voice analysis reached is only 92% which has to be increased.

### 3. Proposed System

Prediction in existing system is weak due to a single classifier system. To overcome the limitation factor (Accuracy) in proposed system Ensemble Technique is used. Ensemble method combines several machine learning techniques into one predictive model in order to decrease variance (bagging), improve predictions (stacking) or bias (boosting).ensemble method is a kind of Meta algorithms means several algorithm or classifiers are combined where the prediction of each classifier is taken into an account and averaged to have final prediction. In proposed system, Naive Baye’s, Cross Validation, F1 Score combination of algorithms is used. Ensemble learning is generally used to improve the (classification, prediction, function approximation, etc.) performance of a model, or reduce the likelihood of an unfortunate selection of a poor. *Data Extraction of Proposed System: X-axis = Time , Y-axis = Frequency*

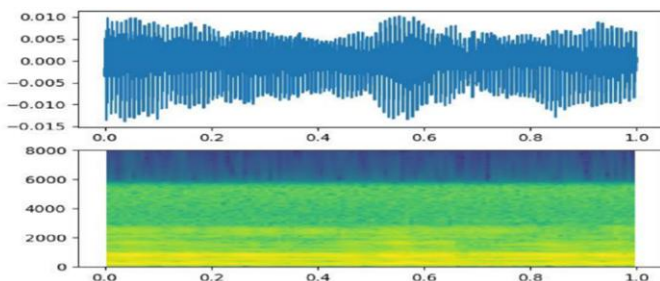


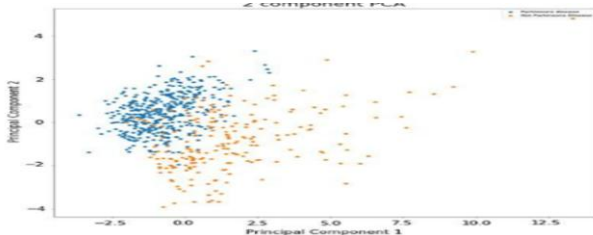
Figure 2. Data Extraction of Proposed System

Table 1. Dispersion Matrix of Proposed System

JITTER LOCAL	JITTER LOCAL ABSOLUTE	SHIMMER LOCAL	SHIMMER LOCAL ABSOLUTE	MEAN PITCH	MEDIUM PITCH	MAX PITCH
0.078	0.135	7.3E-06	0.067	0.078	0.202	7.3E-6
0.081	0.143	7.1E-06	0.73	0.081	0.219	7.1E-6
0.089	0.162	0.000008	0.087	0.089	0.26	.00008
0.089	0.14	6.9E-06	0.075	0.089	0.24	6.9E-6
0.098	0.15	7.2E-06	0.8	0.097	0.23	7.2E-6

*PCA Segmentation of Proposed System:*

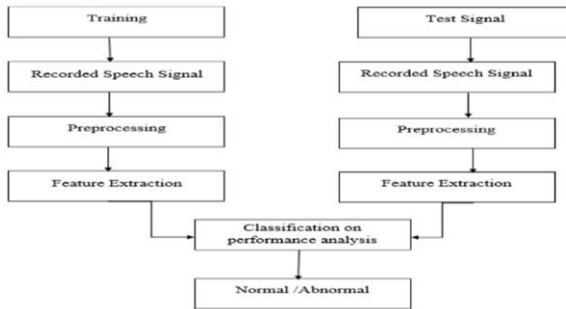
.yellow dots - Non -Parkinson Person .blue dots – Parkinson Person.



*Steps of Proposed System:*

1: In this step we insert the input dataset which has the details about speech signals. Based on the speech signals we identify the Parkinson disease.2: In the second step dataset is converted into a Waveform analysis i.e. data extraction.3: In this step Dispersion matrix is created. Dispersion matrix is nothing but read the data from the data source and created in a matrix form. 4: In this step cross validation done. Once the matrix is created, it will be cross validating the matrix.5: In this step segmentation using PCA is done. PCA is principle component analysis on that basis there are four parameter values are used. We calculate each row in the database using the four parameters values. That’s why PCA is used here. Segmentation is nothing but separate, separately calculating the values.6: In this step using feed forward classification is done based on speech signals. Ensembler technique identifies the diseased patients and non-diseased patients.

*Flowchart of Proposed System:*



Outcome of Proposed System: In this technique we identify the maximum F measure value. The technique works well on the dataset. In 40% non-diseased patients and 60% diseased patients we got a most amazing F-measure from the dataset. Ensembler technique is introduced in this proposed system. In addition to this, it is used for based on the speech signals. Ensembler technique classifies the diseased patients and non-diseased patients. From this project we check the efficiency from the respective dataset. Advantage: 1. Accuracy is increased compared to existing system. 2. Possibility of over-fitting the data. This essentially means that the model has the ability to large dataset. 3.they can be used with less data to dive the models.4. Good for arithmetic and precise calculations.

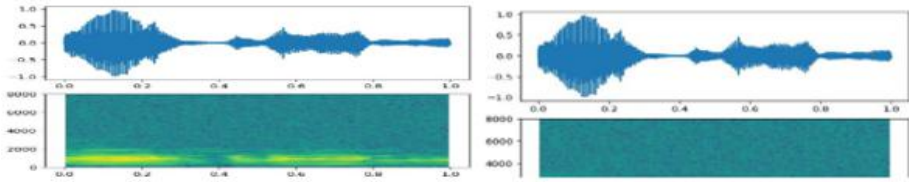
**Steps To Implement:**

1. Collect the sample voice of a person.
2. Convert audio file of the voice sample (mp3) into wave format (.wav).
3. Convert the wave format file (.wav) into CSV file.
4. Use the CSV file as input to the appropriate python code and run the program.
5. If the output shows ‘0’, the person have Parkinson Disease.
6. If the output shows ‘1’, the person doesn’t have Parkinson Disease.

**Results and Discussions:**

**Audio Waveform of Healthy People:**

Here the audio file of the voice sample collected from the person is converted into wave format (.wav) in which the frequency of the voice sample is represented with respect to time. X-axis = Time, Y-axis = Frequency .time. The below graph represents the waveform of Healthy and PD persons.



**Figure 3.** Representation of Normal Person's and PD Person's Frequency Waveform

*Representation of Output* :In proposed system, the accuracy reached is 98%. The F1 score, precision, recall factors are calculated for given input voice sample through python program. As we use ensemble algorithm the strength of the prediction is increased. Thus we overcome the limitation of existing system.

#### 4. Conclusion and Future Enhancement

An efficient classifier combination method is developed with Ensembler technique for addressing PD diagnosis problem. In The proposed method the core component is the Ensembler classifier, whose key parameters are explored in detail. With the aid of the feature selection techniques, especially the performance of Ensembler classifier is ameliorated with much smaller features. from the obtained PD dataset has proven that the proposed classifier combination method can distinguish well enough between patients with PD and healthy persons. the highest classification accuracy of 98% is observed from Ensembler method that it achieves. Based on the empirical analysis, it is concluded safely that, the diagnosis method developed can assist the physicians to make accurate diagnostic decision. The future investigation will pay much attention to evaluating the proposed method in other medical diagnosis problems. In this system, binary attribute (1- diseased patients, 0-non-diseased patients) is used for patient's classification. In future, we will use different types of attributes for patient's classification and also identify the various stages of Parkinson disease.

#### References

- [1] Agarwal, A., Chandrayan, S., &Sahu, S. S. (2016, March). Prediction of Parkinson's disease using speech signal with extreme learning machine. In 2016 International Conference on Electrical, Electronics, and Optimization Techniques (ICEEOT) (pp. 3776- 3779). IEEE
- [2] Aich, S., Sain, M., Park, J., Choi, K. W., & Kim, H. C. (2017, November). A mixed classification approach for the prediction of Parkinson's disease using nonlinear feature selection technique based on the voice recording. In 2017 International Conference on Inventive Computing and Informatics (ICICI)(pp. 959-962). IEEE
- [3] Benba, A., Jilbab, A., Hammouch, A., &Sandabad, S. (2015, March). Voiceprints analysis using MFCC and SVM for detecting patients with Parkinson's disease. In 2015 International conference on electrical and information technologies (ICEIT) (pp. 300-304). IEEE
- [4] Chandrayan, S., Agarwal, A., Arif, M., &Sahu, S. S. (2017, March). Selection of dominant voice features for accurate detection of Parkinson's disease. In 2017 Third International Conference on Biosignals, Images and Instrumentation (ICBSII) (pp. 1-4). IEEE.
- [5] Dimauro, G., Di Nicola, V., Bevilacqua, V., Caivano, D., &Girardi, F. (2017). Assessment of speech intelligibility in Parkinson's disease using a speech-to-text system. IEEE Access, 5, 22199-22208.
- [6] Dastgheib, Z. A., Lithgow, B., &Moussavi, Z. (2012). Diagnosis of Parkinson's disease using electrovestibulography. Medical & biological engineering & computing, 50(5), 483-491. 60

- [7] Dexter, D. T., & Jenner, P. (2013). Parkinson disease: from pathology to molecular disease mechanisms. *Free Radical Biology and Medicine*, 62, 132-144
- [8] Mirarchi, D., Vizza, P., Tradigo, G., Lombardo, N., Arabia, G., & Veltri, P. (2017, August). Signal Analysis for Voice Evaluation in Parkinson's Disease. In 2017 IEEE International Conference on Healthcare Informatics (ICHI) (pp. 530-535). IEEE.
- [9] Orozco-Arroyave, J. R., Belalcazar-Bolanos, E. A., Arias-Londoño, J. D., Vargas-Bonilla, J. F., Skodda, S., Ruz, J., ... & Nöth, E. (2015). Characterization methods for the detection of multiple voice disorders: neurological, functional, and laryngeal diseases. *IEEE journal of biomedical and health informatics*, 19(6), 1820-1828.

# Predictive Analysis of Postpartum Haemorrhage Using Deep Learning Technique

S.V.Ruphitha<sup>a,1</sup> and Dr.V.D.Ambeth Kumar<sup>b</sup>

<sup>a</sup>PG Scholar, Dept of CSE, Panimalar Engineering College, Chennai, India

<sup>b</sup>Professor, Dept of CSE, Panimalar Engineering College, Chennai, India

**Abstract.** Postpartum haemorrhage is the prime source of parental fatality. Postpartum haemorrhage occurs extra blood loss after delivery. If the blood loss occurs more than 500ml, it may create a problem in blood pressure where the women has to go through a lot of pain. Presently, the complete cure are still under research and there is no result which helps to dwindle the endanger of postpartum haemorrhage. Intent process is so supportive inclassifying the danger circumstances and current automation is used. The methodology used here is Deep Learning technique which will be easier to conclude the postpartum haemorrhage in the previous phase. There is an certain stage of postpartum haemorrhage where it can control the blood loss and save the women by permitting higher level treatments. Haemorrhage is one of the major factor responsible for maternal death. Haemorrhage may occur before, during or after delivery of placenta. Based on the amount of blood flow, postpartum haemorrhage will be classified in to two types such as primary and secondary pph. To manage all these problems, methods are handled based on respective situation.

**Keywords:** Women, Risk factors, Postpartum Haemorrhage, Deep Learning Technique.

## 1. Introduction

Postpartum Bleeding is one of the major cause of parental fatality accounting for 60% of maternal deaths in developing countries. Statistics states that the death rate of women is peak within the 4 hours of delivery.75% cases were managed by medical methods whereas rest of the cases are managed by surgical methods. Uterine atony were the highest significant source of postpartum haemorrhage. Postpartum Haemorrhage can be identified by the risk factors such as temperature, blood pressure, sweat rate, heart rate. After maternity period, the pregnant women may attain postpartum haemorrhage which may be primary or secondary pph. Basically , postpartum haemorrhage is divided into two parts such as primary postpartum haemorrhage which occurs within 24 hours of delivery and secondary postpartum haemorrhage which is said to be an retained endometritis.

---

<sup>1</sup>S.V.Ruphitha, PG Scholar, Dept of CSE, Panimalar Engineering College, Chennai, India  
E-mail:ruphitha1798@gmail.com

For the above issues, a new proposed method which is known as deep learning technique will be introduced. The proposed method is to analyse the parameters of women those who suffer the most in labour ward during postpartum haemorrhage. The proposed classification methods have high accuracy to predict the postpartum haemorrhage patients and it also has a fast training process, so it is easy to predict whether the patients are affected by postpartum haemorrhage or not.

## 2. Related work

Identification of Postpartum Infection Type using Mamdani Fuzzy System by Salamah, U [1] a different and un noticed risk factor that is VON WILLIBRAND disease is mentioned and the crucial to management of PPH is early acceptance and treatment. Administration of PPH differs for both the case that includes primary and secondary (i.e)intrauterine massage, oxytocin infusion, methyl prostaglandin and hysterectomy respectively. Postpartum Haemorrhage: A Recurring Pregnancy Complication by Michelle Kominiarek,A [2] provides three methods (i.e) Mechanical: uterine massage, Pharmacological : uterotonics in varying combinations. Surgical: Balloon tamponade, B- lynch sutures, hysterectomy. All possibilities and risk factors are explained and the respective solutions to given is mentioned both through medicines and surgeries. A proposal for postpartum support based on natural language generation model by Zeni Montenegro, J. L [3] tells about the usage of misoprostol and improvement in the third stage of labour. Performing surgeries that include B- lynch sutures, hysterectomy is performed to overcome Uterine atony, cervical damage, retained placenta. Postpartum Haemorrhage by Gowri Ramanathan [4] discusses the major issues addressed and also the Usage of first line therapies and if incurable then adopted to second line therapies and in worst case all advanced surgeries are performed according to the complication. Management of Postpartum Haemorrhage by Rancogz [5] provides the case study and the Concept of 4T (Tissue, Thrombin, Tone, Trauma), uterine atony, resuscitation, Uterine massage, Uterotonic Agent. Cloud-Based Multinomial Logistic Regression for Analysing Maternal Mortality Data in Postpartum Period by Radite Purwahana, R [6] discusses about the emerging value of misoprostol and global initiatives in the management of PPH, will reduce the incidence of this life-threatening condition in the next few years[21-29]. A condom uterine balloon device among referral facilities in Dar Es Salaam: An assessment of perceptions, barriers and facilitators one year after implementation by Adegoke, O [7] gives a successful deliveries with very less inconvenience and damage of the genital parts of women. Very much useful in easy movement of baby in the vaginal canal without tears in the vagina, cervix. Diagnosis and management of postpartum haemorrhage.” Diagnosis and management of postpartum haemorrhage by Edwin Chandharan [8] addresses an issue on Vaginal tears, cervical damage under macrosomy conditions[15-20].

## 3. System Architecture

The below fig.1 represents the complete process of the proposed system. Where the first thing is to get the patient's details and to do data pre-processing. The database will be cleaned once the pre-processing method is done. Then training and testing is to be done by collecting the data and this will be done with the three important steps such as

Confusion matrix, Activation layer and Performance metrics. Confusion matrices will be calculated in the form of true positive, true negative, false positive and false negative. Activation layer consists of relu, tanh, sigmoid. The performance will be measured by using various steps. By applying deep learning techniques, it will be easier to conclude the postpartum haemorrhage at an previous stage. The results will be collected for the two techniques which is used under the concept of convolutional neural network and it will be compared to predict postpartum haemorrhage.

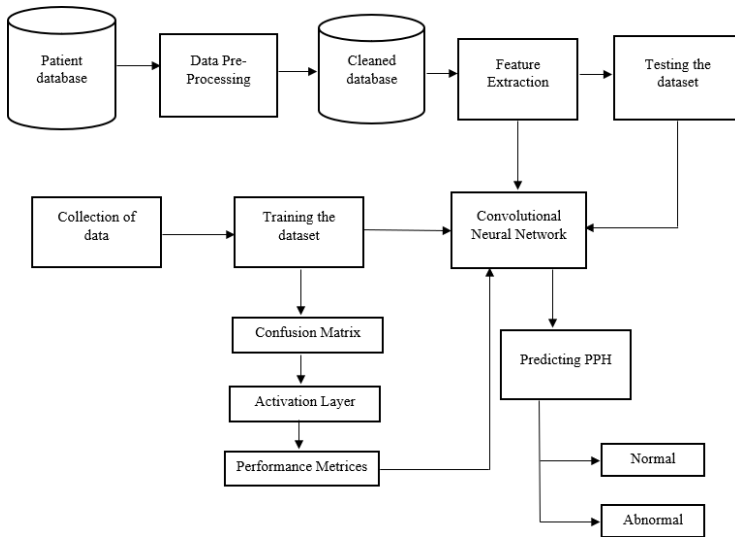


Figure 1. Identifying Postpartum Haemorrhage using Deep LearningTechnique

#### 4. Dataflow Diagrams

##### 4.1 Level 0

Collect a datasets from health care. Process the collected dataset and finding postpartum haemorrhage affected patients.

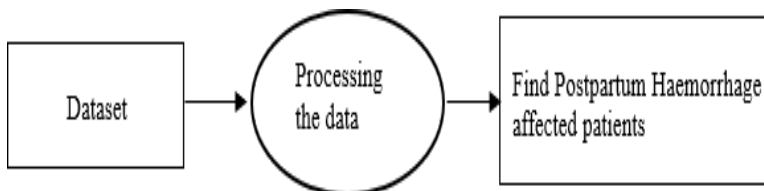


Figure 2. Level 0 DFD Diagram



## 4.2 Level 1

By analysing the parameters, it will be easier to find the women who is affected by postpartum haemorrhage. If any changes occurs in the patient's body, it will be verified with the default value which has been stored previously in database. From the changes, it is easy to know whether the patient has reached critical level or not and it will give an intimation to doctor.

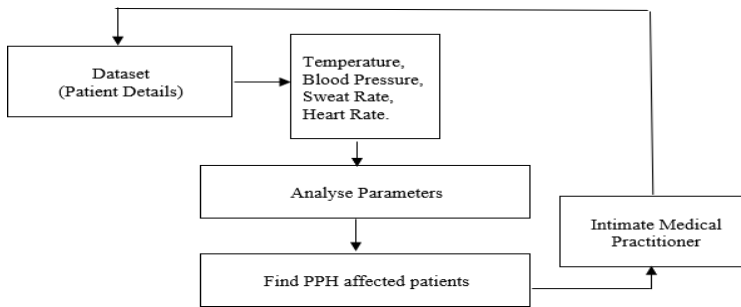


Figure 3. Level 1 DFD Diagram

## 5. Conclusion

In this paper, different parameters have been used and we can easily find the postpartum haemorrhage patients by analysing all the parameters. If the patient level goes abnormal, it makes sure to intimate the medical practitioner and the postpartum haemorrhage affected patients will be identified and prevented easily.

## References

- [1] Salamah, U., Kartikawangi, S., & Suryani, E. Identification of Postpartum Infection Type using Mamdani Fuzzy System ,4th International Conference on Informatics and Computing, ICIC,2019.
- [2] Michelle Kominarek,A., MD, Sarah Kilpatrick, J., MD, PhD. Postpartum Haemorrhage: A Recurring Pregnancy Complication. Seminar in perinatology,2007.
- [3] Zeni Montenegro, J. L., Andre Da Costa, C., Da Rosa Righi, R., Roehrs, A., & Farias, E. R. A proposal for postpartum support based on natural language generation model , International Conference on Computational Science and Computational Intelligence, CSCI , 756–759,2018.
- [4] Gowri Ramanathan, Sabaratnam Arulkumar., Postpartum Haemorrhage, JOCG, 28, 11, 967–973 , 2006.
- [5] Rancogz, Management of Postpartum Haemorrhage (PPH), Management of Postpartum Haemorrhage C-Obstetrics,(43), 2011.
- [6] Radite Purwahana, R., Suryono, S., & Suseno, J. E.. Cloud-Based Multinomial Logistic Regression for Analyzing Maternal Mortality Data in Postpartum Period ,2nd International Conference on Informatics and Computational Sciences, ICICOS, 13–16, 2019.
- [7] Adegoke, O., Danso-Bamfo, S., Sheehy, M., Tarimo, V., Burke, T. F., & Garg, L. F. A condom uterine balloon device among referral facilities in Dar Es Salaam: An assessment of perceptions, barriers and facilitators one year after implementation”,BMC Pregnancy and Childbirth, 20(1), 1–6,2020.
- [8] Edwin Chandraharan, Archana Krishna, Diagnosis and management of postpartum haemorrhage, Diagnosis and management of postpartum haemorrhage. BMJ, j3875,2017.
- [9] Brian Bateman, T., Md Mitchell Berman, F et al, The Epidemiology of Postpartum Haemorrhage in a Large, Nationwide Sample of Deliveries, Anesthesia & Analgesi,110(5),1368-1373,2010.

- [10] Mousa HA, Blum J, Abou El Senoun G, Shakuretal, Treatment for primary postpartum haemorrhage, Cochrane Database of Systematic Reviews, Issue 2,2014.
- [11] Dwight, J., Rouse, MD., MSPH ,What Is New In Postpartum Haemorrhage, American Journal of Obstetric and Gynecology,122(3),693-694,2013.
- [12] Muhammad Muzzammil Edhi , Hafiz Muhammad Aslam, Zehra Naqvi, Edhi et al “Postpartum Haemorrhage : Causes And Management”,BMC Research Notes, 6:236, 2013.
- [13] Dean Leduc, MD., Ottawa Vyta Senikas, MD, Ottawa, ON., et al ,Active Management of the Third Stage of Labour: Prevention and Treatment of Postpartum Haemorrhage, Journal of Obstetrics and Gynaecology Canada, 31(10), 980–993,2009.
- [14] Guillermo Carroli, Luciano Mignini. Episiotomy for vaginal birth. Cochrane Database of Systematic Reviews,(1),2009.
- [15] Hema Kumar,S, J.Uday Kiran, V.D.AKumar, G.Saranya, Ramalakshmi V, “Effective Online Medical Appointment System”, International Journal of Scientific & Technology Research , Volume 8, Issue 09, September 2019, Pages 803 – 805.
- [16] Ambeth Kumar.V.D, Dr.M.Ramakrishnan, V.D.Ashok Kumar and Dr.S.Malathi (2015) . Performance Improvement using an Automation System for Recognition of Multiple Parametric Features based on Human Footprint. for the International Journal of kuwait journal of science & engineering, Vol 42, No 1 (2015), pp:109-132.
- [17] Ambeth Kumar.V.D, V.D.Ashok Kumar, S.Malathi, K.Vengatesan, M.Ramakrishnan .Facial Recognition System For Suspect Identification Using A Surveillance Camera.Pattern Recognition and Image Analysis (Springer), Volume 28, Issue 3, pp 410–420, 2018. (DOI: 10.1134/S1054661818030136)
- [18] Ambeth Kumar.V.D and M.Ramakrishan .Employment Of Footprint Recognition System. in the month of December for Indian Journal of Computer Science and Engineering (IJCSSE) Vol. 3 No.6 Dec 2013
- [19] Ramya,T.,Dr.Malathi,S.,ratheeksha,G.R. and Dr.V.D.Ambeth Kumar. Personalized authentication procedure for restricted web service access in mobile phones.Applications of Digital Information and Web Technologies (ICADIWT), 2014, Page(s):69 - 74, (ISBN:978-1-4799-2258-1)
- [20] Ambeth Kumar.V.D (2018). Novel Wireless Sensing System For The Welfare Of Sewer Laborers. Healthcare Technology Letters (IET) Volume 5, Issue 4, p. 107 –112.
- [21] V.D.Ambeth Kumar, G.Saranya , D.Elangovan, V.RahulChiranjeevi, V.D.Ashok Kumar, “IoT Based Smart Museum Using Wearable Device”, Lecture Notes in Networks and Systems, Vol.55, pp: 33-42, 2018
- [22] Ambeth Kumar.V.D and Dr.M.Ramakrishan(2011) .Footprint Based Recognition System. in the month of April for the International Journal Communication in Computer and Information System (CCIS) Journal (Springer) Volume 147, Part 3, 358-367, DOI: 10.1007/978-3-642-20573-6\_63, April 2011
- [23] Ambeth Kumar.V.D (2017).Efficient Routing for Low Rate Wireless Network a Novel Approach. International Journal of Image Mining, Vol. 2, Nos. 3/4, 2017, 2017
- [24] Ambeth Kumar.V.D, V.D.Ashok Kumar, Dr.S.Malathi and P.Jagaedesh, (2014) .Intruder Identification using Footprint Recognition with PCA and SVM Classifiers.for the International Journal of Advanced Materials Research Vols.1345, PP 984-985 (2014) pp 1345-1349. [DOI:10.4028/www.scientific.net/AMR.984-985.1345]
- [25] Ambeth Kumar.V.D, G.Gokul, S.Malathi, K.Vengatesan, D.Elangovan, B.Chitra.Implementation Of The Pulse Rhythmic Rate For The Efficient Diagonising Of The Heart Beat. Healthcare Technology Letters (IET) 2019 Apr 17;6(2):48-52.
- [26] Ruphitha.S.V et.al.Management of Major Postpartum Haemorrhage by using Zigbee protocol - A Review .2021 6th International Conference on Inventive Computation Technologies (ICICT) (DOI: 10.1109/ICICT50816.2021.9358757 )
- [27] Ambeth Kumar.V.F, Dr.M.Ramakrishnan, V.D.Ashok Kumar and Dr.S.Malathi .Performance Improvement using an Automation System for Recognition of Multiple Parametric Features based on Human Footprint. kuwait journal of science, Vol 42, No 1 (2015), pp:109-132.
- [28] Ramakrishan.M et.al.,Footprint Based Recognition System.in the month of April for the International Journal Communication in Computer and Information System (CCIS) , Volume 147, Part 3, 358-367, DOI: 10.1007/978-3-642-20573-6\_63, April 2011
- [29] Indhumathi.M et al .Healthcare Management of Major Cardiovascular Disease-A review. 2021 6th International Conference on Inventive Computation Technologies (ICICT), (DOI: 10.1109/ICICT50816.2021.9358519 )
- [30] Rajamani.V, S Murugavalli .A High Speed Parallel Fuzzy C-means algorithm for Tumor Segmentation. ICGST International Journal on BIME 6 (1), 2006

# A Comprehensive Survey on Privacy-Security and Scalability Solutions for Block Chain Technology

Puneeth R P <sup>a,1</sup> and Parthasarathy G <sup>b</sup>

<sup>a</sup>Department of Computer Science and Engineering, N.M.A.M Institute of Technology (Visvesvaraya Technological University, Belagavi), Karnataka, India

<sup>a</sup>Research Scholar, School of C&IT, REVA University, Karnataka, India

<sup>b</sup>Associate Professor, Dept of CSE, REVA University, Karnataka, India

**Abstract:** Blockchain has various merits such as decentralization, greater transparency and improved traceability. Nowadays blockchain is used at various numbers of applications such as financial related services, business & industry, integrity verification, governance, health and education sectors. Even though the blockchain technology has promising approaches for the building the future of internet systems and also extensive research is going on about the technical challenges. In this paper we presented the comprehensive survey on blockchain and the techniques that can be used to address the scalability issues with respect to storage and also different privacy preserving techniques that can be incorporated during the implementation of blockchain application.

**Keywords:** Blockchain, Cryptography, Distributed Ledger Technologies, Security, Privacy, Scalability

## 1. Introduction

Blockchain technology is predicted to account 10% of Global Gross Domestic Product (GDP) by 2025 as per the information from World Economic Forum (WEF). Around top 10 promising global IT market research organization will include and continue with blockchain technology reported from United Nations Future Report by the year 2025. Blockchains are generally focuses on financial services but it is gradually expanding to various services as well [3]. Inadequate attention has been dedicated to issues related to the scalability & privacy preserving techniques. However, security attacks, scalability, and privacy concerns could cause a great trouble against the global IoT network [7]. A main functionality of the blockchain is to serve as a distributed system and perform transactions securely. Certain important capabilities are supported by blockchain technology firstly the hash chained storage, next is the use of digital signatures and the suitable consensus technique to add a new block to the

---

<sup>1</sup>Puneeth R P, Dept of CSE, N.M.A.M Institute of Technology, Karnataka, India.

Email: puneeth.rp@nitte.edu.in <sup>1</sup>

existing chain. Mainly digital signatures, merkel hash and hash chain are some of the main features that enhance the security of a blockchain.

## 2. Key Characteristics of blockchain

Decentralization, Security, Accountability, Anonymity and Persistency are the core characteristics of blockchain technology. The Blockchain architecture is distributed in nature. Each node (only miners) within a network has authority to approve, to maintain and to updates the new block entries in to a distributed ledger. The system is usually controlled by everyone within the blockchain network and it is varied based on the type of architecture [1]. Fig.1 provides the comparison between different types of blockchain architecture. It also helps to identify the type of architecture required for the application based on its features.

Characterstics	Public blockchain	Private blockchain	Consortium blockchain
<b>Determination of consensus</b>	All miners participating in network	Group head / Lead node	Set of identified nodes
<b>Accessibility</b>	Public	Could be public / restricted	Could be public / restricted
<b>Efficiency</b>	Low	High	High
<b>Immutability</b>	Can't be tampered	Could be tampered	Could be tampered
<b>Centralized</b>	No	Yes	Partial
<b>Process of consensus</b>	Permission less	Permission required	Permission required
<b>Examples</b>	Bitcoin, Ethereum, Litcoin etc	Ripple (XRP) and Hyperledger	Quorum, Hyperledger and Corda.

**Figure 1.** Comparison between various types of blockchain architecture

## 3. Consensus algorithms

During the process of creation of a new block in a blockchain network, initially the new block is broadcasted to all the nodes of a network, and then each node has the choice whether to consider or to ignore it. So the consensus mechanism is used to take a decision to avoid fraudulent attempts or malicious attacks. The consensus process can be achieved by broadcasting of message between nodes and majority of the nodes has to approve the received message based on the consensus policy. The major consideration is to have a network that should be potential to avoid the degradation of services [1][7].

### 3.1 Approaches to consensus

*Proof of Work (PoW):* It's a consensus mechanism used in an application of Bitcoin network. Basically it requires high computational nodes for solving a challenging puzzle/hard mathematical problem to create a new block. This process is known as "mining", the participants involved in this mining process are called as "miners". The miner who manages to solve the problem will be rewarded and adds the block into the

blockchain. The complexity of the mathematical problem and verify the correctness of solution are the two main features that contributed to wide popularity.

**Proof of Stake (PoS):** It's an energy saving technique alternate to PoW. The Participant nodes should own a cryptocurrency stake to become candidate for validating the new block and to earn a reward fee from it. To create and to validate new block the algorithm chooses the candidate from pool of candidates. During the selection process the algorithm combines the certain factors to make selection fair and to make sure everyone should get a turn.

**Practical Byzantine Fault Tolerance (PBFT):** In PBFT the nodes are sorted in an order with one node acts as a leader (called a primary node) and other nodes referred as backup nodes (called secondary nodes). In case of any failure in the primary node then any one of secondary node can become the primary by transitioning from secondary to primary. PBFT algorithm can work effectively till the set of malicious nodes are not greater than or equal to  $1/3^{\text{rd}}$  of total nodes in the blockchain system. As the participant node increases there is a less chances of being attacked and it leads to more secure network.

**Delegated Proof of Stake (DPoS)** which is an advanced form of PoS, priority based mining process is followed to generate new blocks based on their stake. To generate a new block and to perform the validation a representative is elected by the stake holders. This leads to fewer numbers of nodes to validate the block and transactions are completed early.

Ripple is another consensus algorithm that make uses of accumulatively trusted sub-networks within the group of networks. Especially during the process there will be two types of nodes, mainly the Client-node: used for transferring of only funds and server-node to take part in consensus process. Every ripple server-node has a unique node List(UNL), with the help of UNL ripple server ask every other node and determine whether to put the transaction in to the global /distributed ledger or not.

Tendermint is a consensus algorithm similar to PBFT, to become a validator the tendermint nodes have to lock their coins, if the validator is found to be fraudulent then it would be punished. The new block is identified in a round fashion, initially the proposer broadcast an unconfirmed block, based on the successful completion of pre-vote-step, pre-commit-step, and commit-step, new block is added to ledger. In Fig 2. Summary of the different consensus algorithms based on certain characteristics is discussed [1].

Characteristics	PoW	PoS	PBFT	DPOS	Ripple	Tendermint
Energy efficiency	Less	Moderate	High	Moderate	High	High
Tolerance	Less than 25%	Less than 51%	Less than 33.3%	Less than 51%	Less than 20%	Less than 33.3%
Power of Adversary	computing power	Stake	Faulty replies	Validators	Faulty-nodes in UNL	Byzantine voting power
Node Identity	Open	Open	Permissioned	Open	Open	Permissioned
Example	Bitcoin, Litecoin	Peercoin, Casper	Hyperledger Fabric	Blitshares	Ripple	Tendermint

Figure 2. Comparison of different consensus algorithms

#### 4. Scalability solutions on blockchain

The blockchain is distributed in nature and the immutability is one of the main features. Nowadays different applications are trying to implement using blockchain technology, but there are certain problems associated with that such as number of transactions processed per second, increased chain size, block size issues, electronic signatures size etc. Solving these problems certainly increases the performance of the blockchain, thus scalability issue is one of the most important issue in the blockchain technology.

Various approaches can be followed to solve the scalability problem in blockchain technology. Firstly, On-chain solution for scalability by increasing the block size of transactions in main-chain, in this technique the propagation speed decreases and it is one of its main disadvantages. Next is Off-chain solution: in this approach the processing of transactions happens at outside of the main chain and result is added to main-chain. Side-chain enables a way to exchanging of different blockchain assets with each other, The issue concerned about this approach is all about how to hand independent cryptocurrencies because the value of each crptocurrencies changes day by day. Child-Chain solution follows parent-child format structure, Processing of the transaction happens at the child chain and the processed information is recorded in the parent-chain. Inter-chain solution enables the communication to happen between one or more blockchain, basically it is similar to side-chain approach. We can say inter-chain technique acts as an infrastructure technology for implementing the side-chain. Finally the Chain-splitter is a solution for storage optimization. In this method main blockchain is stored in the cloud environment and the most recently accessed blocks are stored in the overlay network [4]. The scalability of the blockchain problems are classified into mainly three categories such as Cost involved, storage capacity and throughput.[9] In the Fig 3, we tried to list out the possible solution that can be used during the implementation. [2][3]

Category	Solution	Capacity	Throughput	Cost	Advantage	Disadvantage
On-chain	Sharding	Low	High	-	-Low Capacity burden -Parallel Processing	1% attack
	Segwit	-	High	Low	Possibility to apply solutions to bitcoin	Fungibility Occurrence
	MAST	Low	-	-	Strong Privacy	Not Complete Privacy
	Big block	High	High	Low	High Transmission Limit	-Increase of orphan block generation -Centralization of mining
Child-chain	Ethereum Plasma	Low	High	-	Tree structured parent-child blockchain	Expensive verification
Off-chain	Raiden Network	Low	High	Low	Can be used for general purpose application	
	Lightning Network	Low	High	Low	Almost no waiting time and transaction fee	Can be used for payment channel only
Inter-chain	Atomic-swap	-	-	-	Blockchains Interaction	Bounded applicable situation

Figure 3. Comparative analysis of scalability issues

### 5. Security and privacy techniques for blockchain technology

This section provides the summary of different approaches that can be incorporated to improve the security-privacy issues of current system and also for upcoming blockchain systems. Multiple privacy and security properties are required to meet the challenges faced in the complex blockchain system. We would like to highlight three points (i) there is no technology that is perfect in all aspects or that has no defects, whenever we incorporate a new technology to the existing system / complex system, it always bring about new attacks or other problems. (ii) Always there is a compromise between privacy-security techniques and its efficiency. (iii) There is no single technology solution for security and privacy. Many a time’s use of multiple technologies can work better than the use of single technology and also incorporate the security-privacy technology that suits to the required application with acceptable performance. [3][8][6].

Applications	Techniques	Advantages	Disadvantages
CoinJoin, MixCoin	Mixing	It can be used to prevent the address of user’s from being linked.	Leakage of user’s privacy because of centralized services
JUZIX	Group signature	The distinguishing of signer can be hidden among a group of members.	Required a trusted third party for manager
Ethereum	Homomorphic Encryption	Privacy preserving can be achieved by performing operations directly on ciphertext.	The computational efficiency is low for complex functions
EHR management	Attribute-Based Encryption	Data confidentiality & fine grained access can be achieved	Do not consider privacy protection in the phase of key generation
Enigma	Secure Multi-Party Computation(SMPC)/ The Trusted Execution Environment (TEE) Based Smart Contracts	It allows multiparty to perform operation jointly over their private data/ TEE can protect privacy of smart contracts	Complex functions are less efficient / High computational systems are required./ The attacks on Software Guard extensions still need to be resolved.

Figure 4. summary of privacy and security techniques

## 6. Conclusion

The blockchain can be applied to various fields and it has promising solutions for transforming existing industry with its main characteristics. In this paper initially we presented key characteristics of blockchain followed by consensus algorithms. Then we described the different scalability solutions and security-privacy techniques for achieving the better efficiency in blockchain technology. In future we try to explore the feasibility of using different alternate techniques related to security-privacy and scalability methods for the observation of system behavior. Performance evaluation based on certain parameters is also one of the key research areas in blockchain.

## References

- [1] Zibin Zheng,shaoan Xie,Hong-Ning Dai, Blockchain Challenges and Opportunities: a Survey, International Journal of Web and Grid Services, *Vol. 14, No. 4, 2018*.
- [2] Soohyeong Kim, Yongseok Kwon,Sunghyun Cho, A Survey of Scalability Solutions on Blockchain , ICTC 2018, IEEE Xplore.
- [3] RuiZhang and RUI Xue, Security and Privacy on Blockchain , arXiv:1903.07602v2,16 Aug 2019.
- [4] Qiheng Zhou , Huawei Huang , (Member, Ieee), Zibin Zheng ,And Jing Bian ,Solutions to Scalability of Blockchain: A Survey, Volume 8,IEEE Access, 2020
- [5] Merlinda Andonia,, Valentin Robua, David Flynna, Simone Abramb, Dale Geachc, David Jenkinsd, Peter McCallumd, Andrew Peacockd, Blockchain technology in the energy sector: A systematic review of challenges and opportunities , Elsevier, Renewable and Sustainable Energy Reviews 2019.
- [6] Amin Fadaeddini, Babak Majidi, Mohammad Eshghi, Secure decentralized peer-to-peer training of deep neural networks based on distributed ledger technology, The Journal of Supercomputing, Springer-2020.
- [7] RUI ZHANG And RUI XUE, Security and Privacy on Blockchain . Association for Computing Machinery,2019 .
- [8] Xiaoyan Yan, Qilin Wu, and Youming Sun .A Homomorphic Encryption and Privacy Protection Method Based on Blockchain and Edge Computing, Wireless Communications and Mobile Computing Volume 2020 , Article Id 8832341, WILEY-2020.
- [9] Ambeth Kumar.V.D (2017).Efficient Routing for Low Rate Wireless Network a Novel Approach. International Journal of Image Mining, Vol. 2, Nos. 3/4, 2017, 2017
- [10] B. Aravindh; V.D.Ambeth Kumar; G. Harish; V. Siddarth, “ A novel graphical authentication system for secure banking systems”, IEEE (ICSTM), Pages: 177 – 183, 2-4 Aug. 2017, DOI: 10.1109/ICSTM.2017.8089147
- [11] R. Subha Shini et.al., “ Recurrent Neural Network based Text Summarization Techniques by Word Sequence Generation”,IEEE International Conference on Inventive Computation Technologies (ICICT), 2021, DOI: 10.1109/ICICT50816.2021.9358764
- [12] K. Nanagasabapathy; G. Harish; O. I. Allen Sebastian; N. Sowrabh Chandra; V. D. Ambeth Kumar,” Validation system using smartphone luminescence”, IEEE International Conference on Intelligent Computing, Instrumentation and Control Technologies (ICICT), Pages: 235 – 239, 2017. DOI: 10.1109/ICICT1.2017.8342566



# An Efficacious Text Summarization Process Using Triple Encoding-Decoding Mechanism

V.D.Ambeth Kumar <sup>a</sup>, R.SubhaShini<sup>b</sup>, K.Priyanka<sup>b</sup>

<sup>a,b</sup>*Department of CSE, Panimalar Engineering College, Chennai*

**Abstract.** As the big data and internet growing huge day by day, there is in need to overwhelm people by the information in large. These kind of issues makes researchers to create a technique that can generate automatic text. This research is very great interesting topic and the summarization of text is the process which undergoes finding important information within a document. Automatic text summarization is the process where a subset is created which represents the relevant content using the original text trained. So, text summarization is an intimidating challenge in Natural Language Processing because getting a good summary is a very big challenge as it is based on various aspects like metrics, non-redundancy, readability etc., At the outset, the text is trained into the system, next the trained text is fed into encoder decoder process where additional techniques are employed between the result in best coherent summary. The aim of automatic text summarization is to the produce finest and top quality text summary and our model also produces supreme quality summary.

**Keywords--** big data, automatic text, text summary.

## 1. Introduction

This is an era where huge and huge amount of facts available on internet. It's a very main thing to give a well-developed technique to pick out important content very efficiently and rapidly. Enormous text materials are available on World Wide Web. So it is very strenuous process to find and search a document, and distilling relevant information from it. The automatic text summarization is necessary to solve the problem given before. Summarization is a thing which is highly necessary for the text summarization. So, it is important to know what is meant by a summary. A summary is nothing but a paragraph which is constructed by more texts, contains collection of sentences which conveys to give important needful information. The target of automatic text summarization is to present the original trained input text into a best version paragraph. The main and chief merit of using the summary is to reduce the time of reading

Extractive and abstractive are types of summarization under text summarization. The extractive text summarization does a procedure of selection of main content which is sentences, words etc., from source text file that is concatenated to form a shorter summary. The abstractive text summarization does a procedure of understanding the subject and concept which is chief in the document and generates that concept in a clear form of summary. Informative and inductive are the two different kinds of text summarization where summarization of inductive does the representation of main text idea to the user. This type of summarization typically has a length of 5-10% of text present in the main document. The summarization of informative system provides great information and typically has a length of 20-30% of text present in the main document.

## 2. Literature Survey

In the year of 2019, Md. MotiurRahman et al have proposed a system where the purpose is, from an input of long text an automatic summarization of text is generated by using a methodology of Multi-layered Attentional Peephole Convolution LSTM (Long Short-term Memory) (MAPCoL). The merit of the system is, it can generate a summary which is more precise [1]. An Abstractive text summarization system is introduced by S Gehrmann et al in the year of 2018 where the system produces a content that is simple but also the selection of content which is accurate from the original text by using a methodology of data-efficient content selector and bottom-up attention. Here, the fluent summary of text is generated by using this approaches which results in compressing text ability [2]. In the year of 2018, K Al-Sabahi et al generated summaries with more and more novelty and high level of abstraction by proposing his system [18-31].

The summary of text is very much novel which is the main advantage here in this system where the system uses the methodology of end-to-end trainable bidirectional RNN model. A mechanism is also proposed that is bidirectional beam search mechanism with an algorithm [3]. AM Rush et al proposed a system which generates summary that must have each and every word present in input sentence trained in the year of 2015. The system uses the main methodology of local attention-based model which improves the quality as well as the inconsistency produced while the summary of text is generated. The demerit of the system is, while generating text summary there is no good improvement in the grammatical part [4]. The system of extractive document summarization is proposed where a neural sequence model for extractive document summary generation will allow the intuition for text visualization. The system is proposed by R Nallapati et al in the year of 2016 where a Summa RuNNer is presented by him that can give a better in performance [5]. In the year of 2018, for conceptualization of extractive summary generation as a task of sentence ranking and for proposal of an algorithm of novel training, a system is proposed by S Narayan et al by using a methodology of sentence ranking and novel training algorithm. The CNN/DailyMail dataset is used here for the experiment where the system's algorithm is used for training the neural summarization model on the dataset used in this approach. The system is not perfect and gets confused in arranging sentences accordingly (i.e., ranking of sentences) is the demerit of this system [7]. The abstractive text summarization system is proposed here to enhance semantic representation of text by R Nallapati in the year of 2016 [8]. The system uses a methodology of Attentional Encoder-Decoder Recurrent Neural Networks and also several novel models are

proposed which will provide some of the problems happened in the summarization. He also proposes a new dataset which will have the summaries of multi-sentence and the disadvantage of this system is, long text semantic representation is very difficult.

### 3. System Architecture

The diagrammatic representation of the text summarization process is shown below. The system is trained with input text which is employed to triple encoding. The result of the triple encoding and the key information, contextual information from the triple encoding result is fed into the process decoding. Thus, the decoder outputs the resultant automatic text summary.

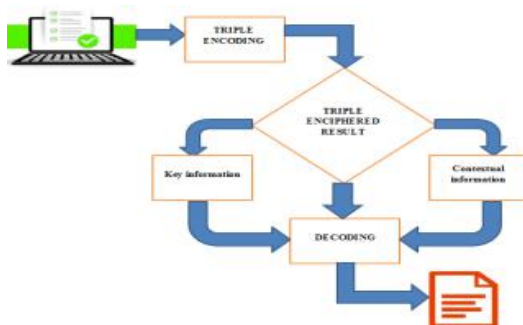


Figure 1. Text summarization process

### 4. Data Flow Diagrams

#### 4.1 level 0

The system is trained with the input source text where this trained text is fed into the part of triple encoding and decoding and the target summary result is obtained.

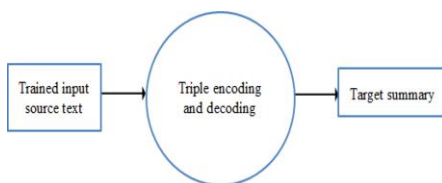


Figure 2. Level 0 DFD

#### 4.2 Level1

The trained input text is given into triple encoding to produce first and second encipher result. The result of first and second encipher is collected into double enciphered result which is fed into third encipher process. The third encipher is fed into decoding process to result in target summary.

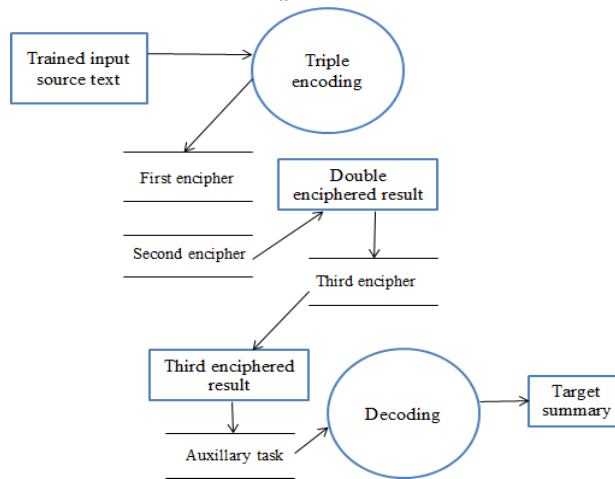


Figure 3. Level 1 DFD Diagram

## 5. Conclusion

Thus, the automatic text summarization process produces finest and top quality text summary and also produces supreme quality summary. The text is trained into the system, next the trained text is fed into encoder-decoder process where additional techniques are employed between, to result in generation of best summary.

## References

- [1] Rahman, M., Siddiqui, F.H..An Optimized Abstractive Text Summarization Model Using Peephole Convolutional LSTM. mdpj-Symmetry,2019.
- [2] Gehrmann, S., Deng, Y., Rush AM..Bottom-up abstractive summarization. Proceedings of the 2018 Conference on Empirical Methods in Natural Language Processing, Association for Computational Linguistics,2018.
- [3] Al-Sabahi, K., Zuping, Z., Kang, Y..Bidirectional Attentional Encoder-Decoder Model and Bidirectional Beam Search for Abstractive Summarization. Computation and Language (cs.CL), 2018.
- [4] Rush, A.M., Chopra, S., Weston, J..A neural attention model for abstractive sentence summarization. Proceedings of the 2015 Conference on Empirical Methods in Natural Language Processing,2015.
- [5] Nallapati, R., Zhai, F., Zhou, B..Submariner: A recurrent neural network based sequence model for extractive summarization of documents. The Thirty-First AAAI Conference on Artificial Intelligence,2016.
- [6] Zhou, Q., Yang, N., Wei, F., Huang, S., Zhou, M..Neural document summarization by jointly learning to score and select sentences. The 56th Annual Meeting of the Association for Computational Linguistics,2018.
- [7] Narayan, S., Cohen, S.B., Lapata, M.: Ranking sentences for extractive summarization with reinforcement learning. the 16th Annual Conference of the North American Chapter of the Association for Computational Linguistics,2018.
- [8] Nallapati et.al, Abstractive text summarization using sequence- to-sequence rnns and beyond. The SIGNLL Conference on Computational Natural Language Learning (CoNLL),2016.
- [9] Cheng, J., Lapata, M..Neural summarization by extracting sentences and words. the 54th Annual Meeting of the Association for Computational Linguistics,2016.
- [10] Jen-TzungChien and Yuan-Chu Ku.Bayesian Recurrent Neural Network for Language Modeling. IEEE Transactions on Neural Networks and Learning Systems Volume: 27, Issue: 2,2016.
- [11] Chopra, S.et.al.Abstractive sentence summarization with attentive recurrent neural networks. Proceedings of the conference of NAACL-HLT, Association for Computational Linguistics, 2016.

- [12] Deepanagalavi, Hanumanthappa, M., Ravikumar, K..An Improved Attention Layer assisted Recurrent Convolutional Neural Network Model for Abstractive Text Summarization. INFOCOMP Journal of Computer Science, 2019.
- [13] Qingyu Zhou, Nan Yang, Furu Wei, Ming Zhou.Selective Encoding for Abstractive Sentence Summarization. Asia-Pacific Web (APWeb) and Web-Age Information Management (WAIM), 2017.
- [14] QianGuo, Jifeng Huang, NaixueXiong, Pan Wang: MS-Pointer Network.Abstractive Text Summary Based on Multi-Head Self-Attention. IEEE Access, Journal Article, Publisher: IEEE, Vol. 7, 2019.
- [15] Song, S., Huang, H., &Ruan, T., “Abstractive text summarization using LSTM-CNN based deep learning”, *Multimedia Tools and Applications* 78, Springer, 857–875,2019.
- [16] Bing, L., Li, P., Liao, Y., Lam, W., Guo, W., “Abstractive multi-document summarization via phrase selection and merging”, *Association for Computational Linguistics (ACL)*,2015.
- [17] KaichunYao,LiboZhang,DaweiDu,TiejianLuo,LiliTao,YanjunW
- [18] S.Hema Kumar, J.UdayKiran, V.D.AKumar, G.Saranya, Ramalakshmi V, “Effective Online Medical Appointment System”, *International Journal of Scientific & Technology Research*, Volume 8, Issue 09, September 2019, Pages 803 – 805.
- [19] V.D.Ambeth Kumar, Dr.M.Ramakrishnan, V.D.Ashok Kumar and Dr.S.Malathi (2015) “Performance Improvement using an Automation System for Recognition of Multiple Parametric Features based on Human Footprint” for the *International Journal of kuwait journal of science & engineering*, Vol 42, No 1 (2015), pp:109-132.
- [20] V.D.Ambeth Kumar, V.D.Ashok Kumar, S.Malathi, K.Vengatesan, M.Ramakrishnan, “Facial Recognition System For Suspect Identification Using A Surveillance Camera”, *Pattern Recognition and Image Analysis (Springer)*, Volume 28, Issue 3, pp 410–420, 2018. (DOI: 10.1134/S1054661818030136)
- [21] V.D.Ambeth Kumar and M.Ramakrishnan. Employment Of Footprint Recognition System. in the month of December for *Indian Journal of Computer Science and Engineering (IJCSE)* Vol. 3 No.6 Dec 2013
- [22] Ramya,T.,Dr.Malathi,S.,ratheeksha,G.R. and Dr.V.D.Ambeth Kumar (2014). Personalized authentication procedure for restricted web service access in mobile phones. *Applications of Digital Information and Web Technologies (ICADIWT)*, 2014, Page(s):69 - 74, Bangalore, India (ISBN:978-1-4799-2258-1)
- [23] Ambeth Kumar.V.D et.al.Novel Wireless Sensing System For The Welfare Of Sewer Laborers. *Healthcare Technology Letters (IET)* Volume 5, Issue 4, p. 107 –112, 2018
- [24] Ambeth Kumar.V.D, G.Saranya , D.Elangovan, V.RahulChiranjeevi, V.D.AshokKumar.IOT Based Smart Museum Using Wearable Device.Lecture Notes in Networks and Systems, Vol.55, pp: 33-42, 2018
- [25] Ambeth Kumar.V.D and Dr.M.Ramakrishnan .Footprint Based Recognition System. in the month of April for the *International Journal Communication in Computer and Information System*, Volume 147, Part 3, 358-367, DOI: 10.1007/978-3-642-20573-6\_63, April 2011
- [26] Ambeth Kumar.V.D (2017) .Efficient Routing for Low Rate Wireless Network a Novel Approach. *International Journal of Image Mining*, Vol. 2, Nos. 3/4, 2017, 2017
- [27] V.D.Ambeth Kumar, V.D.Ashok Kumar, Dr.S.Malathi and P.Jagaeedesh, (2014) “Intruder Identification using Footprint Recognition with PCA and SVM Classifiers” for the *International Journal of Advanced Materials Research* Vols.1345, PP 984-985 (2014) pp 1345-1349. [DOI:10.4028/www.scientific.net/AMR.984-985.1345]
- [28] Ambeth Kumar.V.D, G.Gokul, S.Malathi, K.Vengatesan, D.Elangovan, B.Chitra.Implementation Of The Pulse Rhythmic Rate For The Efficient Diagonising Of The Heart Beat.*Healthcare Technology Letters (IET)* 2019 Apr 17;6(2):48-52.
- [29] S.V. Ruphitha et.al, Management of Major Postpartum Haemorrhage by using Zigbee protocol - A Review. 2021 6th International Conference on Inventive Computation Technologies (ICICT) (DOI: 10.1109/ICICT50816.2021.9358757 )
- [30] Ambeth Kumar.V.D, Dr.M.Ramakrishnan, V.D.Ashok Kumar and Dr.S.Malathi (2015) “Performance Improvement using an Automation System for Recognition of Multiple Parametric Features based on Human Footprint” *kuwait journal of science*, Vol 42, No 1 (2015), pp:109-132.
- [31] M.Ramakrishnan et.al.Footprint Based Recognition System. in the month of April for the *International Journal Communication in Computer and Information System (CCIS) Journal (Springer)* Volume 147, Part 3, 358-367, DOI: 10.1007/978-3-642-20573-6\_63, April 2011
- [32] Indhumathi.M et.al .Healthcare Management of Major Cardiovascular Disease-A review. 2021 6th International Conference on Inventive Computation Technologies (ICICT), (DOI: 10.1109/ICICT50816.2021.9358757 )
- [33] R. Subha Shini et.al., “ Recurrent Neural Network based Text Summarization Techniques by Word Sequence Generation”,*IEEE International Conference on Inventive Computation Technologies (ICICT)*, 2021, DOI: 10.1109/ICICT50816.2021.9358764

# Facial Expression Recognition Under Occlusion Conditions Using ACNN

Balasundaram<sup>a,1</sup>, Ashokkumar<sup>b</sup>, Saravanan A<sup>c</sup>, Sathish Kumar P J<sup>d</sup>, Balaji<sup>S<sup>d</sup></sup>

<sup>a,1</sup>Assistant Professor, School of Computer Science and Engineering, Vellore Institute of Technology (VIT), Chennai, India

<sup>b</sup>Assistant Professor, Department of CSE, Saveetha School of Engineering (SIMATS), Chennai, India

<sup>c</sup>Professor, Dept of ECE, SMK Fomra Institute of Technology, Chennai, India

<sup>d</sup>Associate Professor, Department of CSE, Panimalar Engineering College, India

**Abstract.** This work proposes a Convolution Neural Network with attention mechanism (ACNN), resembling that human understanding the emotion. Naturally, human perceives the facial emotions depending on particular parts of the face. Several clues are gathered from different parts of face like mouth, lips, cheeks etc, and these are in turn analyzed by the learning model to decide on the facial expression. This work uses ACNN to handle the scenario of occlusion as well.

**Keywords.** Facial Expression Recognition, FER, CNN

## 1. Introduction

Recognizing facial expressions (FER) has got huge interest from researchers and analysts over the years, as it caters to a number of uses, for example, human-computer interaction, influence examination, and psychological well-being evaluation. The FER frameworks that acts impeccably in the gathered dataset images, are plausible to act inadequately while perceiving people expressions under normal and abnormal scenarios. To enclose the void between the FER precision in the controlled appearances and uncontrolled portraits, scientists put forth attempts for gathering huge scope facial expressions datasets in nature. In spite of the utilization of information from the wild, outward appearance acknowledgment is as yet testing because of the presence of incompletely impeded countenances. Occlusion might brought about by hair, sun glasses, muffler, mask, beard, arms, moustache, and different items that might be set before the faces in our routine life. These items may hide some portion of cheeks, eye, eyebrows, mouth, and some more facial features

ACNN naturally sees the impeded facial fixes and focuses principally to the unblocked and enlightening patches. Each and every Gate Unit in ACNN learns a versatile load by un-obstructiveness or significance. At that point, the Occluded portrayals are linked and utilized in the classification part. In this manner ACNN can be

---

<sup>1</sup>Balasundaram A, Assistant Professor, School of CSE, Vellore Institute of Technology, Chennai, India; E-mail: balasundaram2682@gmail.com<sup>1</sup>

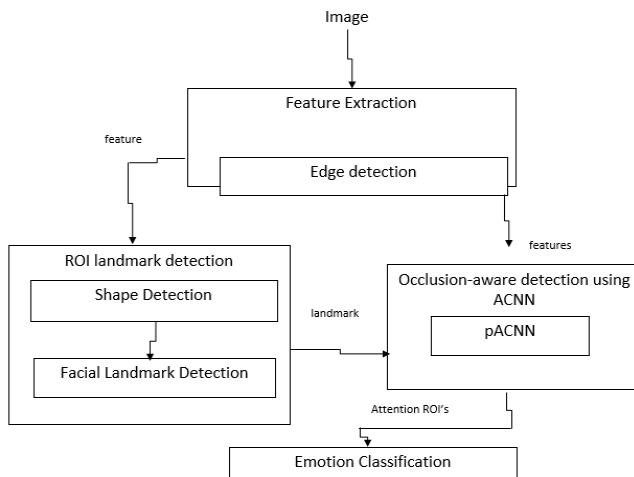
accurate in on particular just as unhampered areas in facial picture. Examination on emotion detection is a difficult field that target strategies to make compelling human computer interaction. Face Image signal contains huge amount of important information with mental disorder and emotion of people. Later enhancements here have urged the specialists to expand the pertinence of facial emotion acknowledgment to zones like chat room symbols and video conferencing avatars. Thus identification of emotions from occlusion based images is the current research area. The major problem that starts with this system is that dataset images could be of low quality and our model does not supports that kind of images. Though increased number of epochs increases accuracy, our system gets slower due to load of the model. Also choosing dataset images according to our system and face has to fit in our frame, it will be another difficulty while training the model.

## 2. Related Works

As indicated by Nithisha Raut Face discovery has been around for a long time. Stepping forward, human feeling showed by face and felt by mind, caught in either video, electric sign (EEG) or picture structure can be approximated. Human emotion recognition is the need of great importance so present day by insightful frameworks can copy and check responses from face. This can be useful to settle on choices be it with respect to recognizable proof of aim, advancement of offers or security related dangers. Perceiving feelings from pictures or video is an insignificant assignment for natural eye, however ends up being trying for machines and requires many picture preparing procedures for include extraction. Several works using computer vision [12-22] have been done in FER analysis. A few AI calculations are appropriate for this work. Any identification or acknowledgment by AI requires preparing calculation and afterward testing them on an appropriate dataset. This paper investigates a few AI calculations just as highlight extraction methods which would help us in precise recognizable proof of the human feeling [1]. In the work of Naveen Kumar H N, Jagadeesha S [2], subject independent FER in the case of from semi-occluded images has been discussed.. As indicated by, Jiabei Zeng, Shiguang Shan and Yong Li [3], a trainable neural network that uses patch-gated convolution (PG-CNN) has been used to study FER in occluded scenario. In the work done in [4], K-nearest neighbor (K-NN), facial expression recognition and Support Vector Machine (SVM) classifiers are applied and tested. According to Susmita Moitra and Souvik Choudry [5], several CNN based approaches to classify the basic human emotions in occluded scenarios has been analyzed.

## 3. Proposed System

In real time, occlusion is a serious issue and may have direct bearing on FER performance. The obstruction may be caused by beard, sun glasses, muffler, hairs, food and other objects that could be placed in front of the faces in daily life. These objects may block the eyebrows, lips, cheeks, and any other part of the face, thus making the emotion recognition difficult. Thus the occlusion problem statement is not yet addressed in the previous research papers, just emotion recognition on controlled environment is been discussed.



**Figure 1.**Proposed System Architecture diagram.

The proposed framework tends to the complexity of impediment, we introduce a Convolutional Neural Network mindfully instrument (ACNN) which can see the impediment districts of the face and work in the most discriminative un-blocked areas. It joins the numerous portrayals from facial areas of intrigue (ROIs). Thinking about various ROIs, we present fix based ACNN (pACNN). pACNN just focuses on neighbourhood facial patches. The proposed ACNNs are assessed on standard self-gathered outward appearance dataset with certifiable impediments, the two biggest in-the-nature outward appearance datasets (RAF-DB and AffectNet) and their changes with blended facial impediments. Outward appearance is recognized in specific facial areas, in light of the fact that the articulations are facial exercises summoned by group of muscle movements. Figure 1 shows the architecture of the proposed system. The image is given as input into the convolutional model and get some feature inlets. Initially, image size will be  $224 \times 224$  and gets encoded into  $512 \times 28 \times 28$  when it enters into nine convolutional layer. ACNN breaks feature maps into several sub feature maps. The region decomposition is completed through aligning the facial image by fixing the 68 facial landmark round the face and dividing the facial landmark into 24 patches which covers all the informative region. The cropped patches enter pg-unit and divided into two branches. the primary branch represent the vector-shaped feature maps where it's un-weighted image and therefore the second branch represent the eye net where each patches are weighted. pACNN is meant to specialize in local discriminative and representative patches. In addition, partitioning the face into various local parts assists to find the placements of obstructions. To identify the standard parts of face that are combined with expression, We first find certain landmark of faces pointed by the proposed method, Then supported the identified points, we chose or recompute few details that hides the essential parts of the face, such as nose, mouth, cheeks, eyes. Then we take the patches consistent with the angles of every subject's landmarks of face. ACNN sent the feature maps into gACNN. The global local-based ACNN has local information in the image and represent the global clues. The weight ranges from  $[0, 1]$  where the 0 represent the occluded part and 1 represent the un-occluded part. This module indicates the benefaction of universal people face presentation [22]. Universal



representation is then calculated by the computed weight. Unit considers the feature maps  $\tilde{\pi}_i$  as input, then learns localized facial features  $\psi_i$ :

$$\psi_i = \psi(\tilde{\pi}_i) \quad (1)$$

and a corresponding weight  $\alpha_i$ :

$$\alpha_i = I_i(\tilde{\pi}_i)$$

$\psi_i$  is a variable that represents the non-weighted features.  $\alpha_i$  is a constant that represent the patch  $i$ 's importance. The fully connected layers integrates the weight of pg-unit and gg-unit. Based on their weight the emotion are classified. It is obvious that gACNN results in promising classification validity on surprised, scared sections respectively. The potential candidate expressions for confused expressions are surprise and fear, sad and neutral, fear and neutral are little concern.

#### 4. Experimental Results

For the experimental result analysis, we have used pycharm tool with python script for image processing and machine learning techniques.



Figure 2. Sample output of the experiment.

Occlusion dataset images are collected from kaggle and given as the input file to the application. Finally based on the input images provided, our application recognizes the respective emotions. Figure 2 shows the sample outputs of the proposed solution. The results of the model looks promising. It shows the percentage of the key emotions from the occluded face. Also using this model, we can be able to view mixed emotions in occluded face of a specific person.

#### 5. Conclusion and Future Works

As part of this work, a CNN based approach namely - ACNN for emotion recognition in occlusion scenarios has been presented. The Gate Unit present in the ACNN facilitates the model to move attention from the occluded parts to other unobstructed also as unique facial areas. Taking that countenance is distinguished in marked facial areas, a patch based pACNN was designed that comes up with region decomposition to identify facial parts that determine facial expressions. Also, an efficient gACNN to feed global facial details for FER in occlusion scenarios was developed. The proposed system analyses the potential of ACNNs to move the attention from obstructed areas to other similar areas. As part of future work, the way to produce monitoring parts in

faces without regions of interest, as ACNNs believe identical face detection and facial regions of interest placement modules can be explored.

## References

- [1] Y. Li, J. Zeng, S. Shan, and X. Chen, Patch-gated CNN for occlusion-aware facial expression recognition, in Proc. Int. Conf. Pattern Recognit. (ICPR), Aug. 2018, pp. 2209–2214. [7] J. Wright, A. Y. Yang, A. Ganesh, S. S. Sastry, and Y. Ma, Robust face recognition via sparse representation, IEEE Trans. Pattern Anal. Mach. Intell., vol. 31, no. 2, pp. 210–227, Feb. 2009.
- [2] S. Li, W. Deng, and J. Du, Reliable crowdsourcing and deep locality preserving learning for expression recognition in the wild, in Proc. CVPR, Jul. 2017, pp. 2584–2593.
- [3] Naveen Kumar H N, Jagadeesha S Subject Independent Automatic Facial Expression Recognition from Partially Occluded Still Images by Employing Appearance Based Feature Extraction Schemes, 2019.
- [4] Zhao G, X. Huang, M. Taini, and S. Z. Li, Facial expression recognition from near-infrared videos, Image Vis. Comput., vol. 29, no. 9, pp. 607–619, 2011.
- [5] Mollahosseini A, B. Hasani, and M. H. Mahoor. (2017). AffectNet: A database for facial expression, valence, and arousal computing in the wild. [Online]. Available: <https://arxiv.org/abs/1708.03985>
- [6] Vikram K and S. Padmavathi, Facial parts detection using Viola Jones Algorithm, International Conference on Advanced Computing and Communication Systems (ICACCS-2015) on, 2017.
- [7] P. Lucey, J. F. Cohn, T. Kanade, J. Saragih, Z. Ambadar, and I. Matthews, The Extended Cohn-Kanade Dataset (CK+): A complete dataset for action unit and emotion-specified expression, in Proc. CVPRW, Jun. 2010, pp. 94–101.
- [8] M. Pantic, M. Valstar, R. Rademaker, and L. Maat, Web-based database for facial expression analysis, in Proc. ICME, Jul. 2005, p. 5.
- [9] L. Wiskott, J. M. Fellous, N. Kuiger and C. V. Malsburg, Face Recognition by Elastic Bunch Graph Matching, IEEE Transactions on Pattern Analysis and Machine Intelligence, vol. 19, no. 7, pp. 775–779, 1997.
- [10] M. S. Bartlett, J. R. Movellan and S. Sejnowski, Face Recognition by Independent Component Analysis, IEEE Transactions on Neural Networks, vol. 13, no. 6, pp. 1450–1464, 2002.
- [11] Balasundaram, A., Chellappan, C. An intelligent video analytics model for abnormal event detection in online surveillance video. J Real-Time Image Proc 17, 915–930 (2020).
- [12] A. Balasundaram and C. Chellappan, Vision Based Motion Tracking in Real Time Videos, 2017 IEEE International Conference on Computational Intelligence and Computing Research (ICIC), Coimbatore, 2017, pp. 1–4, doi: 10.1109/ICIC.2017.8524504.
- [13] A. Balasundaram, C. Chellappan, Vision Based Gesture Recognition: A Comprehensive Study, The IIOAB Journal, Vol.8, Issue.4, pp.20–28, 2017.
- [14] Balasundaram, A., Ashok Kumar, S., & Magesh Kumar, S. (2019). Optical flow based object movement tracking. International Journal of Engineering and Advanced Technology, 9(1), 3913–3916.
- [15] Balasundaram, A., & Chellappan, C. (2019). Computer vision based system to detect abandoned objects. International Journal of Engineering and Advanced Technology, 9(1), 4000–4010.
- [16] Balasundaram, A., Ashokkumar, S., Sasikumar, A. N., Kajendran, K., & Sathish Kumar, P. J. (2020). Computer vision and machine learning based facial expression analysis. International Journal of Advanced Trends in Computer Science and Engineering, 9(5), 7421–7426.
- [17] S. Magesh Kumar; Balasundaram A; Sasikumar A N; Sathish Kumar P J. Human Emotion Prediction – A Detailed Study. European Journal of Molecular & Clinical Medicine, 7, 4, 2020, 1991–2001.
- [18] A Balasundaram et al Computer vision based fatigue detection using facial parameters"2020 IOP Conf. Ser.: Mater. Sci. Eng. 981 022005
- [19] D Kothandaraman, A Balasundaram, SeenaNaikKorra, E Sudarshan and B Vijaykumar Enhancing dull images using discrete wavelet families and fuzzy"2020 IOP Conf. Ser.: Mater. Sci. Eng. 981 022020
- [20] Balasundaram, A. Computer Vision based Detection of Partially Occluded Faces. International Journal of Engineering and Advanced Technology, 9(3), 2188–2200.
- [21] Balasundaram, A, Ashokkumar, S. Study of Facial Expression Recognition using Machine Learning Techniques. JCR. 2020; 7(8): 2429–2437.
- [22] Ambeth Kumar V.D et al. Facial Recognition System For Suspect Identification Using A Surveillance Camera. Pattern Recognition And Image Analysis (Springer), Volume 28, Issue 3, Pp 410–420, 2018. (Doi: 10.1134/S1054661818030136)

# Intelligent Vehicle Scrutiny to Eradicate Malversation

Suthanthara Raja Pushpa<sup>a,1</sup> Valarmathi K<sup>b</sup>

<sup>a,1</sup>PG Scholar, Dept of CSE, Panimalar Engineering College, Chennai

<sup>b</sup>Professor, Dept of CSE, Panimalar Engineering College, Chennai

**Abstract.** In this modern world, there is an increasing crisis in monitoring the safety measures in the traffic field. Though there are many methods and techniques developed to find a solution to this particular problem, there is an empty or faulty field which each and every one tried to cover at each of their findings. One such problem is the malversation. This plays the major role in the traffic field through which the public who don't have enough driving experience, alcohol consumer and those who park their vehicle in no parking area which lead to the congestion and many other facts have been roaming freely without any fear causing disturbance to the public. Even the cops who are responsible for the safety of public and to monitor the traffic with full dedication they allow the criminals to flee away by getting bribes. So, in order to terminate this system, there is an urgent need to find an appropriate solution in this fields. Our paper has been proposed with this problem statement as their main goal and developed a system in Internet of things.

**Keywords.** IOT, Malversation, Congestion, No parking area, Cops, Police etc.

## 1. Introduction

Internet of things is one of the most adopted technique in all the fields as they are user friendly and can be maintained at regular intervals of time at low cost. Internet of things is the connection of number of objects to the network. Any system that reduces the workload of human kind is the Internet of Things. These objects can be simple in structure or be more complexed to crack it. It depends on the platform for which use they are being developed. Several papers and articles have been coming into existence to improve the features of several methodology. Though they have numerous solution they all have some defects in common to all the systems. Accuracy of the system plays the vital role in determining the quality of the system. Numerous papers have taken into consideration in literature survey learning about many methods. But no methods have a perfect hundred accuracy. Methods like SVM (Support Vector Machine) and Image Processing have been adopted by many authors for their easy methods to get the output. Output have been produced as per their expectation but it resulted in the short span of life. As days goes by the data get started to ruptured as we cannot store and maintain

---

<sup>1</sup> J. Suthanthara Raja Pushpa, PG Scholar, Dept of CSE, Panimalar Engineering College, Chennai –  
E-mail: pushpastarmalar@gmail.com

the vast amount of electronic data. A tabular format of all the techniques learnt and understood thus far have been computed for ease of use. Some methodology has some defects which will be resulting on low accuracy. Each method adopted have used various kinds of algorithm and steps to yield a better result. Some may be of same techniques but to get better accuracy than the previous findings, they have been adopted. Their drawbacks have been computed through which they have lost their accuracy when competing with others. These drawbacks are most common in some kind of papers as they will be using similar algorithms.

**2. Related works**

Works including various techniques are taken into consideration. Methodology like MLT (Machine Learning Techniques) and SVM are used in some papers but they do not have the desired output. Thus, the researchers moved to Image processing technique. Here the image obtained have been processed to yield the accurate image. These images get ruptured as days goes by as there is no separate method to store and maintain them at protected cost. Machine learning technique have been used to find the vehicle that breaks the law and this method made the simple structure of the system into a complex one. They do not provide an accurate result and the researchers spent their time in other domains like blockchain, license plate detection, etc. Ensemble learning also provide the least accuracy and thus cannot be adopted for the vast area of the network and to put forward for public use.

Intelligent vehicle tracking system have a robot developed and featured for the specific action. This robot runs behind the vehicle that is assigned to track and thus to have an activated response from the user. This method was effective to be implemented in public. But the robot that runs behind the targeted vehicle is tend to get crashed or damaged by the vehicle that comes behind them. Thus, this method also faced a failure process. HSV (Hue Saturation Value) technique is implemented in some papers. But when the climate changes this gets affected as the human cannot control the nature. They get blurred and do not provide the result with satisfactory solution. Moreover, they get damaged in weather and the data stored are lost. This system has weak protected feature and thus cannot be implemented for public use in a long period of time as they get damaged by the natural calamities.

RFID (Radio Frequency Identifier) plays a vital role in this developing project and have many advantages in this technique. They can be installed anywhere and are easy to maintain in this vast area of network. Both the RFID sender and receiver are fixed in the selected spot and are connected to the centralized server. The server acts as a connectivity to detect the charges from the client’s wallet. The database has all the records of the individual user and keeps track of the crime count in their system.

**Table 1.** Method adopted so far and their accuracy and drawbacks which paved the way for the emergence of new methodology

S: NO	METHODOLOGY	ACCURACY	DRAWBACKS
1	IOT	95%	Hardware units does not function properly when there is an error.
2	Image Processing	80%	Image takes gets ruptured as days goes by.

3	V2V	30%	Miscommunication leads to the confusion state of the vehicle and the monitoring end.
4	Blockchain	25%	The least method used as they have various error in working.
5	License plate detection	67%	Image dets destroyed or get faded.
6	Surveys	70%	Statistics gives the desired result in theory but not in practical.
7	Video capturing	87%	Videos gets damages after some years without proper maintenance.
8	HSV	90%	They get damaged to climate changes which cannot be fixed in human end.
9	Gray scaling	86%	Slicing out to get perfect image leads to data loss.
10	On-board unit	75%	Possibilities of malfunction on running.
11	RFID	89%	Physical damage to the RFID tags is possible.
12	Hidden Markov model	60%	Does not give desired solution to problem statement.
13	Machine learning	40%	Makes the system more complex.
14	Tracking robot	30%	Robots can get damaged while under work.
15	SVM	54%	No desired output is obtained.
16	Incident detection	70%	Physical damage to the system lead to the faulty state
17	Ensemble learning	30%	Does not provide the required result
18	Probabilistic neural network	15%	Complexity of the system is high.
19	VANET	45%	Not applicable to all the areas.
20	Behavior analysis	40%	Not predictable

### 3. Methodology

Proposed project consists of RFID tag that have both RFID receiver and RFID sender. Streets and paths that are required to be monitored are to be fitted with RFID receiver to track and scan the vehicles. The vehicle has to be attached with the RFID tag. This RFID tag have some unique features that contain the complete details provided by the user in initial stage.

The architecture diagram shows the pathway of the project that is being developed. They have separate sections for detection of vehicle in parking area or not, penalty detection, cancellation process, etc. They have a centralized server that serves as communication bridge among the user and the system. The information collected from the user and the activities done by the mobile client are being recorded completely in that particular RFID tag. Each RFID tag have unique numbers.

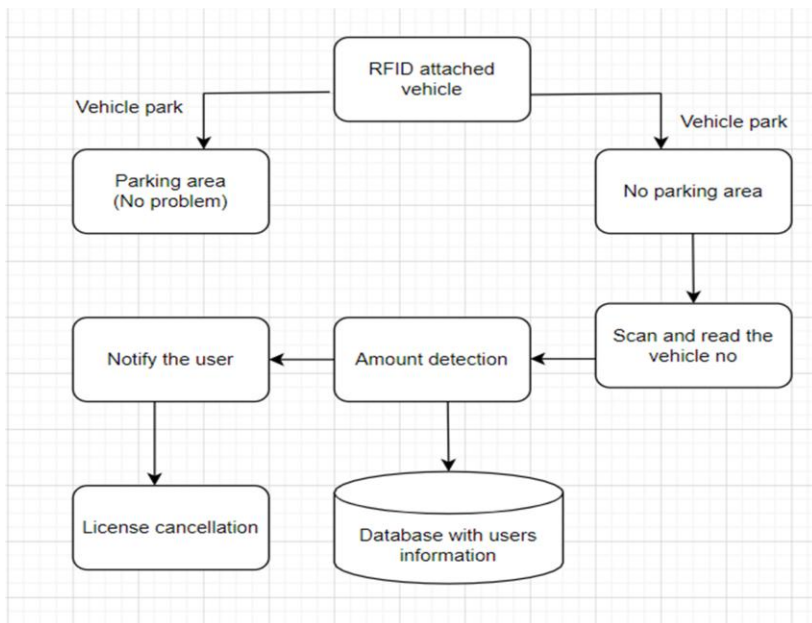


Figure 1. Architectural diagram

Maximum of three excuse is provided in this system. When the client takes up more than three excuse this system gets informed and will lead the way to cancel the license of the mobile client. Even when the mobile client does not respond to the alert the police will take action and will go and inspect the mobile client’s resident in person which has been provided in the registration phase. This reduces the malversation to high impact and reduce the manual inspection of the cops and other process. This can be fitted in all the public area where there is a high risk of congestion during peak hours. They provide online monitoring and tracking of the vehicles which is ease of use and to have a great work line in public.

**4. Conclusion and future work**

Thus, a system using RFID has been developed and been implemented in the needy area. This method helps in identifying the vehicle that breaks the law in order and being a main reason for congestion. That particular vehicle has to be scanned using RFID receiver and get the required details that are stored in the database which is the centralized server. The details that are registered in the first phase have to be kept safe as that will be responsible for all the activities of the mobile client. Cancellation and

penalty have to be taken care at the police end as they have a separate section for that particular monitoring system. This method has produced better results when compared to many other systems and have a reliable feature which will be of great help in the near future. This method helps to a great extent and provide a helping hand in eradication of the malversation in traffic field that gain trust and respect among public to police.

## References

- [1] Y. Gu, Z. Qian, and F. Chen, From Twitter to detector: Real-time traffic incident detection using social media data, *Transportation Research Part C: Emerging Technologies*, vol. 67, pp. 321–342, 2016.
- [2] J. D. G. Paule, Y. Sun, and Y. Moshfeghi, On fine-grained geo- localization of tweets and real-time traffic incident detection, *Information Processing & Management*, vol. 56, no. 3, pp. 1119–1132, 2019.
- [3] Zhang.Z, Q. He, J. Gao, and M. Ni, A deep learning approach for detecting traffic accidents from social media data, *Transportation Research Part C: Emerging Technologies*, vol. 86, pp. 580–596, 2018.
- [4] Dabiri.S and K. Heaslip, Developing a Twitter-based traffic event detection module using deep learning architectures, *Expert Systems with Applications*, vol. 118, pp. 425–439, 2019.
- [5] Abuelela.M, S. Olariu, M. Cetin, and D. Rawat, Enhancing automatic incident detection using vehicular communications, in *2009 IEEE 70th Vehicular Technology Conference Fall*, pp. 1–5, IEEE, Anchorage, AK, USA, 2009.
- [6] J. Lu, S. Chen, W. Wang, and B. Ran, Automatic traffic incident detection based on nFOIL, *Expert Systems with Applications*, vol. 39, no. 7, pp. 6547–6556, 2012.
- [7] R.Vidhya, K.Valarmathi.Automatic Monitoring of Hydroponics System Using IoT. *Lecture Notes on Data Engineering and Communication Technologies*, volume 35, pp 641-648, 2020
- [8] Dhivya, K Valarmathi .IoT Based Smart Electric Meter.Lecture Notes on Data Engineering and Communication Technologies, volume 35, pp 1260-1269, 2020.
- [9] R. Wang, S. Fan, and D. B. Work, Efficient multiple module particle filtering for joint traffic state estimation and incident detection, *Transportation Research Part C: Emerging Technologies*, vol. 71, pp. 521–537, 2016.
- [10] M. Fogu, P. Garrido, F. J. Martinez, J. C. Cano, C. T. Calafate, and P. Manzoni, Automatic accident detection: assistance through communication technologies and vehicles, *IEEE Vehicular Technology Magazine*, vol. 7, no. 3, pp. 90–100, 2012.
- [11] S.V. Ruphitha et.al.Management of Major Postpartum Haemorrhage by using Zigbee protocol - A Review .2021 6th International Conference on Inventive Computation Technologies (ICICT) (DOI: 10.1109/ICICT50816.2021.9358757 )
- [12] Ambeth Kumar.VD . Novel Wireless Sensing System For The Welfare Of Sewer Laborers. *Healthcare Technology Letters (IET) Volume 5, Issue 4*, p. 107 –112, 2018
- [13] Ambeth Kumar.V.D, G.Saranya , D.Elangovan, V.RahulChiranjeevi, V.D.Ashok Kumar.IOT Based Smart Museum Using Wearable Device. *Lecture Notes in Networks and Systems*, Vol.55, pp: 33-42, 2018
- [14] Ambeth Kumar.V.D andDr.M.Ramakrishnan.Fingerprint Based Recognition System. in the month of April for the *International Journal Communication in Computer and Information System*, Volume 147, Part 3, 358-367, DOI: 10.1007/978-3-642-20573-6\_63, April 2011
- [15] Ambeth Kumar.V.D (2017).Efficient Routing for Low Rate Wireless Network a Novel Approach. *International Journal of Image Mining*, Vol. 2, Nos. 3/4, 2017, 2017
- [16] Hema Kumar.S, J.UdayKiran, V.D.AKumar, G.Saranya, Ramalakshmi V, “Effective Online Medical Appointment System”, *International Journal of Scientific & Technology Research*, Volume 8, Issue 09, September 2019, Pages 803 – 805.
- [17] Ambeth Kumar.V.D, Dr.M.Ramakrishnan, V.D.Ashok Kumar and Dr.S.Malathi (2015).Performance Improvement using an Automation System for Recognition of Multiple Parametric Features based on Human Footprint. *kuwait journal of science*, Vol 42, No 1 (2015), pp:109-132.
- [18] B.Akshaya, M.Rajendiran.Securing Documents Using Digital Certificate-A Review. *International Journal of Research in Advent Technology (IJRAT)*, 2018

# Cyber Bullying Scrutiny for Women Security in Social Media

Madhubala.D<sup>a,1</sup>, Rajendiran. M<sup>b</sup> and Elangovan.D<sup>b</sup>, Priya.R<sup>c</sup>

<sup>a,1</sup>PG Scholar, Dept of CSE, Panimalar Engineering College, Chennai

<sup>b</sup>Professor, Dept of CSE, Panimalar Engineering College, Chennai

<sup>c</sup> Assistant Professor, Dept of CSE, Panimalar Engineering College, Chennai

**Abstract.** In recent year, the number of users in social media has been increased multiple times when compared to the past. So most of them are aware about the current affairs in day today life. It is the medium for the user to express the opinion without facing any difficulty. At the same there will be a lot of bullying occurs in social media. The bullying like abuse word, aggressive text or posting some unwanted message. So the women feel unsecured in the society. Although a lot of techniques and methodology has been raised, but still the problem remain same. The major problem is the abuse word can be eliminated by the mean of report to the particular social media. In this methodology the unwanted message can be truncated in between the sender and receiver itself .So there other person cannot be affected in the cyberbullying .Also the unstructured data can be increased in the social media. So it leads to complex for analyzing the text. With the help of sentiment analysis, we can easily filter the unwanted text. Based on the criteria, the paper has been proposed with the problem statement as a main goal and developed a system in machine learning.

**Keywords.** Machine learning, Cyber bullying, socialmedia, Aggressiveword etc.

## 1. Introduction

Nowadays most of people use the social media in both positive way as well as negative ways .So most of them are aware about the current situation about the country, education or technology basis .The social media is an ideal platform for the youngster, because if there is any tweets about the organization, employment as well as the opportunity for exposing the ideas and also we can update the current technology and social activities. The users in social media can be increased by day -today life. However through the social media, user can freely express the view about the current situation. Similarly the most of the celebrity can actively interact the fans through the social media. In current trends most of them are actively participated in social media., Likewise the politician, business man, common people and other higher authority can also available in media. The social media platform consists of nearly millions of people .In the same manner, the negative ways are posting aggressive comment , offences in the form of abuse word . Based on threat, the women suffer a lot which

---

<sup>1</sup>D.Madhubala, PG Scholar, Dept of CSE, Panimalar Engineering College, Chennai - 600123;  
E-mail: madhubaladakshina@gmail.com



leads to psychology problems such as stress, mood swing and suicide can also occur. The main aim of this system is to provide the precautionary steps to prevent the women in social media platform. However, it also assists to analyses the threats against in social networking sites. The goal of this system is to filter the unwanted text which is against the women in the form of threats or violence's. With the help of the machine learning technique we can predict the text in social media.

## 2. Related works

Today social networking sites is the fast growing sites among the teens. So there is possibility for vulnerable to get exposed to bullying. In this paper they are discussed the supervised learning technique to detect cyberbullying. For feature detection ,they consider the two hypotheses to find the abuse comment or offensive comment .Based on the comment they faces the negative consequence. The initial experiment shows that the features using hypothesis .Furthermore with traditional extraction techniques like N-gram,TF-IDF can be used for increasing the accuracy in the system.[1]

There is an increase in endangered text occurs among the young people in online [2]. The recent report demonstrate that cyberbullying is one of the major problem in social networking sites.In this paper, they focused the bullies, victims and bystanders in social media. In automatic cyberbullying ,they performed the series of binary classification for better feasibility. Similarly they use the linear support vector machine for manipulating the feature set.

Vinita Nahar, Sanad Al-Maskari et al[3] has proposed that semi-supervised learning with fuzzy SVM algorithm. Since current approach is based detection can be static and also they find the difficulty to handle the imbalanced data efficiency and noisy. They consider the different evaluation scenarios to indicates the superiority of the proposed fuzzy SVM is better than all the existing method.The significant phenomenon on harassment by cyberbullying in social media. The existing system proposed that the three bottleneck approach [4]. The objective of the first approach is only on the social media platform. The second approach focus on address (like hashtag) just the topic based analysis can be done. And then the third approach is feature of the data which is already predefined. So the author proposed that the deep learning concept to overcome the bottle neck approach. . SemiuSalawu , Yulan He et al [5] suggested that the systematic review on cyber bullying detection on social networking site. Most of the research paper focused on the machine learning and natural language processing technique. In supervised learning mainly focus on the SVM and naive bayes classification and also in lexicon based uses the presences of word for categorize the bullying words. The challenging task is the combination of cross model with the various modalities and dependencies between the structural. So they proposed the XBully framework [6]. Similarly the algorithm are naive bayes, Support Vector Machine , JRIP is RIPPER Algorithm ,Projective Adaptive Resonance Theory ,K-Nearest Neighbor, Decision Tree, Logistic Regression , Artificial Neural Network for identification and detection for cyber bullying content. And also the accuracy can be increased by F-measure [7].The social media users has been increasing day by day .So there is a harmful threat message has been received by user [8]. It mainly cause the negative impact on the person's life and also even society faces the teen suicides. However the author proposed the automatic detection of harmful message in social

media. It is based on word embedding and also we can expand the list of predefined insulting word[16-30].

### 3. Methodology

The below Fig.1 depicts the detection of cyberbullying text. First we need to load the cyberbullying dataset. After that the dataset can be preprocessed .In preprocessing step, it involve the tokenization of the text, removal of special character and stemming. Then we need to extract the features from preprocessing. Finally ,it involve the machine learning algorithm and then we need to integrated with twitter API .At last it remove the harmful tweet against women.Generally social media allow the people to share the information and provide effective communication among the society .At the same time, it as the negative side for the women such as abuse words and also posting some bad comment against women.So they suffer a lot and also even lead to the negative impact on the personal life. Threats can also occur from normal women to the celebrity women. The abuse word and aggressive word is generally referred as a Cyberbullying .In digital communication, the message can be send by the individual or group of the people perform the cyberbullying activities against the victim.

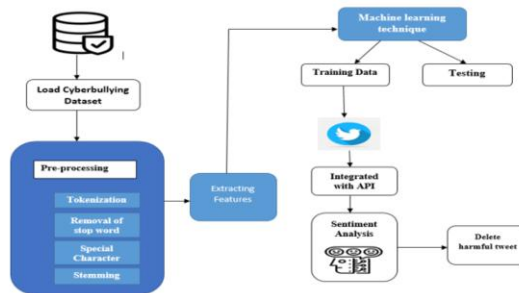


Figure 1. Architectural diagram

### 4. Data Flow Diagram

#### 4.1 Level 0

This diagram represents that extracted text in twitter (input.txt) is given as an input to the Twitter classification where the system is already trained to detect cyberbullying dataset from the text and gives the result based on training given to the system.



Figure 2. Level 0 DFD Diagram

## 4.2 Level 1

The Cyber Bullying text is given as an input to the system and text is given into the pre-processing step .Then the text is tokenized and then integrated into the twitter API which can detect the threats or abuse words in social media.

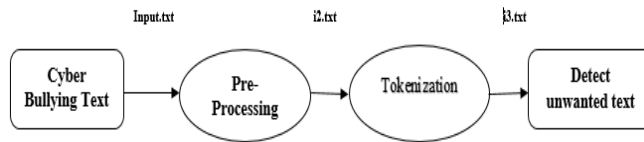


Figure 3. Level 1 DFD Diagram

## 5. Conclusion and future work

In this paper, we have collected several data set for detecting the cyberbullying text. This methodology of collecting opinions of people from social media enables a quantitative information across the globe including the rate of their sentimental feelings on harassment, providing a strong base for improving and empowering security. This way of analyzing sentimental feelings of public and providing guidelines in order to lessen insecure problems arising in the society would definitely help in reducing the risk of these nauseous activities acting upon society. This proposed system would recommend various guidelines for detecting aggressive word and precautionary efforts needs to be establish by the government and public awareness to save the woman from the various violence in the form of sexual harassments. This model also takes advantage to alert the woman from the difficult situations. Further, the system provide better efficiency when compared to other systems. And also it provide more safety to the women in an effective manner.

## References

- [1] Vikas S Chavan, Shylaja S S, Machine Learning Approach for Detection of Cyber-Aggressive Comments by Peers on Social Media Network , Proceeding of International Conference on Advances in Computing, Communications and Informatics (ICACCI),2015
- [2] Cynthia Van Hee , Gilles Jacobs , Chris Emmery, Bart Desmet, ElsLefever, Ben Verhoeven, Guy De Pauw, Walter Daelemans and VéroniqueHoste, Automatic detection of cyberbullying in social media text ,Journal of PLOS one,2018.
- [3] Vinita Nahar,Sanad Al-Maskari,Xue Li,Chaoyi Pang, Semi-supervised Learning for Cyberbullying Detection in Social Networks ,proceeding on 25<sup>th</sup> Australasian Database Conference,2014.
- [4] Sweta Agrawal, Amit Awekar, Deep Learning for Detecting Cyberbullying across Multiple Social Media Platforms, Proceeding on European Conference on Information Retrieval, 2018.
- [5] SemiuSalawu; Yulan He; Joanna Lumsden , Approaches to Automated Detection of Cyberbullying: A Survey ,Journal of IEEE Transaction on Affective Computing, Volume: 11,2020.
- [6] Lu Cheng, Jundong Li, Yasin N. Silva, Deborah L. Hall,
- [7] Akshi Kumar,Nitin Sachdeva, Cyberbullying Checker: Online Bully Content Detection Using Hybrid Supervised Learning, International Conference on Intelligent Computing and Smart Communication ,2019
- [8] Rui Zhao, Anna Zhou, Kezhi Mao, Automatic detection of cyberbullying on social networks based on bullying features , Proceedings on 17th International Conference on Distributed Computing and Networking,2016.

- [9] Harsh Dan, Jundong Li .Huan Liu, Sentiment Informed Cyberbullying Detection in Social Media , Journal of Computer Science, 2017.
- [10] Reynolds K, Kontostathis A, Edwards L , Using Machine Learning to Detect Cyberbullying, Machine Learning and Applications and Workshops (ICMLA),proceedings on 10th International Conference , vol.2, pp.241,244,2011.
- [11] Nahar, V, Li, X, Pang, C, Zhang, Y, Cyberbullying detection based on text-stream classification , Proceedings of the Eleventh Australasian Data Mining Conference , 2013.
- [12] Bretschneider U, Wöhner T and Peters R, Detecting online harassment in social networks , Proceeding on Thirty Fifth International Conference on Information Systems ,2014.
- [13] Abeele MVand De Cock R, Cyberbullying by mobile phone among adolescents: The role of gender and peer group status ,vol. 38, no. 1, pp. 107-118, 2013.
- [14] Akshaya.B, M.Rajendiran, Securing Documents Using Digital Certificate-A Review. International Journal of Research in Advent Technology (IJRAT) , 2018
- [15] Lu Cheng, RuochengGuo, Yasin Silva, Deborah Hall and Huan Liu, Hierarchical Attention Networks for Cyberbullying Detection on the Instagram Social Network, Proceedings of SIAM International Conference on Data Mining ,2019.
- S.Hema Kumar, J.UdayKiran, V.D.AmbethKumar,G.Saranya, Ramalakshmi V, “Effective Online Medical Appointment System ”, International Journal of Scientific & Technology Research, Volume 8, Issue 09 September 2019, Pages 803 – 805.
- [16] Ambeth Kumar.V.D, Dr.M.Ramakrishnan, V.D.Ashok Kumar and Dr.S.Malathi (2015) “Performance Improvement using an Automation System for Recognition of Multiple Parametric Features based on Human Footprint”, kuwait journal of science , Vol 42, No 1 (2015), pp:109-132.
- [17] Ambeth Kumar.V.D, V.D.Ashok Kumar, S.Malathi, K.Vengatesan, M.Ramakrishnan .Facial Recognition System For Suspect Identification Using A Surveillance Camera.Pattern Recognition and Image Analysis (Springer), Volume 28, Issue 3, pp 410–420, 2018. (DOI: 10.1134/S1054661818030136)
- [18] Ambeth Kumar.V.D and M.Ramakrishan .Employment Of Footprint Recognition System. in the month of December for Indian Journal of Computer Science and Engineering (IJCSE) Vol. 3 No.6 Dec 2013
- [19] Ramya,T.,Dr.Malathi,S.,rathheeksha,G.R. and Dr.V.D.Ambeth Kumar (2014). Personalized authentication procedure for restricted web service access in mobile phones. Applications of Digital Information and Web Technologies (ICADIWT), 2014, Page(s):69 - 74, Bangalore, India (ISBN:978-1-4799-2258-1)
- [20] V.D.Ambeth Kumar (2018) . Novel Wireless Sensing System For The Welfare Of Sewer Laborers. Healthcare Technology Letters (IET) Volume 5, Issue 4, p. 107 –112.
- [21] V.D.Ambeth Kumar, G.Saranya , D.Elangovan, V.RahulChiranjeevi, V.D.Ashok Kumar, “IoT Based Smart Museum Using Wearable Device”, Lecture Notes in Networks and Systems, Vol.55, pp: 33-42, 2018
- [22] V.D.Ambeth Kumar and Dr.M.Ramakrishan .Footprint Based Recognition System.in the month of April for the International Journal Communication in Computer and Information System, Volume 147, Part 3, 358-367, DOI: 10.1007/978-3-642-20573-6\_63, April 2011
- [23] V.D.Ambeth Kumar (2017).Efficient Routing for Low Rate Wireless Network a Novel Approach. International Journal of Image Mining, Vol. 2, Nos. 3/4, 2017, 2017
- [24] V.D.Ambeth Kumar, V.D.Ashok Kumar, Dr.S.Malathi and P.Jagaedesh, (2014).Intruder Identification using Footprint Recognition with PCA and SVM Classifiers.for the International Journal of Advanced Materials Research Vols.1345, PP 984-985 (2014) pp 1345-1349. [DOI:10.4028/www.scientific.net/AMR.984-985.1345]
- [25] V.D.Ambeth Kumar, G.Gokul, S.Malathi, K.Vengatesan, D.Elangovan, B.Chitra .Implementation Of The Pulse Rhythmic Rate For The Efficient Diagonising Of The Heart Beat. Healthcare Technology Letters (IET) 2019 Apr 17;6(2):48-52.
- [26] S.V. Ruphitha et.al . Management of Major Postpartum Haemorrhage by using Zigbee protocol - A Review .2021 6th International Conference on Inventive Computation Technologies (ICICT) (DOI: 10.1109/ICICT50816.2021.9358757 )
- [27] Ambeth Kumar.V.D, Dr.M.Ramakrishnan, V.D.Ashok Kumar and Dr.S.Malathi (2015).Performance Improvement using an Automation System for Recognition of Multiple Parametric Features based on Human Footprint. kuwait journal of science, Vol 42, No 1 (2015), pp:109-132.
- [28] Rajamani.V, S Murugavalli, “ A High Speed Parrallel Fuzzy C-means algorithm for Tumor Segmentation”, ICGST International Journal on BIME 6 (1), 2006
- [29] Dhivya.M, K Valarmathi .IoT Based Smart Electric Meter .Lecture Notes on Data Engineering and Communication Technologies, volume 35, pp 1260-1269, 2020.

# Facilitation of Smart car Assistant System Using IoT

M.Nithya<sup>a,1</sup>, M.V.S.SoundaryaLahari<sup>b</sup>, J.C.E Sai Sumitra<sup>b</sup> and V. Lalitha<sup>b</sup>

<sup>a,1</sup>Department of CSE, Sri Sairam Engineering College, Chennai, India

<sup>b</sup>Department of CSE, Sri Sairam Engineering College, Chennai, India

**Abstract:** Human protection in cars has been the primary area of study in the past few years. A significant issue for groups of researchers and industrialists around the world is -crash-. Car users often overcome problems related to trapping in a car of car causing suffocation kind of problems, where immediate communication is very much essential. Similarly a problem often arises when it comes to the collision of vehicles from back side. This paper proposes a smart car personal assistant system that provides an efficient solution for the problems like collision detection, being trapped inside a car and also provides a necessary support by using IoT and Creation of an android application consisting of critical characteristics such as contact in the above potential problems, renewal of PUC, periodic expenditure of vehicle-related items, regular check-ups and maintenance, car database and user information of the car, which will minimize user efforts.

**Key-words:** Suffocation, Collision, Smart Car, Arduino, Alerts, Monitoring.

## 1. Introduction

### 1.1 Domain Overview

The Internet of Things (IoT) is a subtle collection of technologies and uses a simple, single concept of inbound instances. One effective framework for viewing IoT such as the use of network-connected devices, entrenched in a visible environment, to enhance the present process. These devices, or objects, are connected to a network to supply information which would be collected from an environment with the help of the sensors. They can be connected by phone to common objects that you may already be familiar with, or to new devices designed for the purpose of unreachable activities. The IoT environment is only beginning with enormous use cases and possibilities through diverse industries and scenarios that set a common challenge and pattern.

### 1.2 Objective

The key objective of this paper is to provide a secured and an efficient solution for the consistent and evident problems in daily life. Considering the human safety as a major

---

<sup>1</sup>M.Nithya Corresponding Author, Department of CSE, Sri Sairam Engineering college, India. ; E-mail: nithya.cse@sairam.edu.in

factor in non-crash related accidents in car, the proposed system is capable of Sensing the suffocation levels of at rapped occupant, Sensing the presence of human in a turned off car, Intimating the people around and users connected about the fatal situations Alerting users by detecting cars to prevent rear-end collisions. The most essential part considering the safety and comfort in automobile is 'automation of anti-suffocation system'. The big concern is the death in locked vehicle soft toddlers, disabled person sand animal sowing to Asphyxiation .Therefore, a device that automatically works with minimum power consumption and disbursement is required to address this form of threat to human life. Heat stroke in automobiles is the leading cause of most crash-related fatalities, Pursuant to the National Highway Traffic Safety Administration (NHTSA). 556 children in the United States of America have died in a locked car since 1998. (USA). Children under the age of 15 accounted for nearly 15 per cent of traffic-free deaths between 2006 and 2010. One child dies in the U.S. every 10days due to a vehicle heatstroke. An average of 53 children die in hot cars each year after being trapped in motor vehicles due to suffocation. It can take up to 15 minutes for kids to suffer from malignant brain-kidney injuries in a heated vehicle. [The Hindu June13,2015]In a recent case, two kids has been trapped in this situation where they took the car keys to play inside . When they closed the door, the car was centrally locked .Sadly, the two sisters didn't know how to unlock the door, and the windows were closed and locked. Parents were unaware of it and checked inside and outside the home. They found the missing car key several hours later and eventually, they found their kids dead inside. They emanated to realize later that suffocation was the cause of death. The main reason behind these fatalities is that when vehicles are parked without overhead garages in a hot environment and with the engine off, doors and windows locked and outside temperatures above 33°C, the inside temperature will rise in a short time above the comfort limit. This may hyperthermia for a child or disabled. It clearly describes the state of observation that most percentage of people end up leaving their children in the cars for shopping which they think would be a short time work .But at eventual delay of shopping coincides with the accidental lock of car then this would cause an unexpected accident which could result anything. This pie chart does not includes the cases where physically challenged people may also end up locked inside car due to some reasons. This is because there is no such accidents caused and the prediction of happening this is 0.089% according to researchers. With the rise in deaths due to the suffocation epidemic, vehicle surveillance and child protection/human safety inside a car has become a considerable problem all over the world. There are no existing and systematic solutions in the scenario for law enforcement agencies (LEAs) and vehicle tracking for the safety of the child / person inside the car. Our endowment is to provide reasonable proof of the prototype. To track the child inside the car and provide a security solution with instant data control feature, we provide an advanced solution framework. Below is the main goal of the work of the research project, which will lead us to improve the prototype further. The presence of adults, children and luggage in a car seat should be separated, To have the controlling intervention to save a child's life. When it comes to the crash related accidents, Road accidents are the most unwanted things to happen. The general rules and safety measures are well known to most road users when using highways, but it is really the sensitivity of road users that causes accidents and crashes. The main cause of accidents and crashes is human error. One those errors is the distraction. The distraction may be outside or inside the vehicle.

Talking on a mobile phone while driving is now a big distraction. A large part of the brain is consumed by the activity of talking on the phone and a small part retains driving skills. This brain division impairs reaction time and the ability to judge. This can be a cause for crashes. Attending the telephone calls while driving should be avoided. You must pull out on the side of the road to take part in the call if the call is urgent. Adjusting mirrors, vehicle stereo/radio, road animals, banners and billboards while driving on the road are necessary. These distractions can cause the collision between vehicles. To avoid those type of collisions, the driver must be alerted every time to avoid collision of vehicles. The present system provides frequent monitoring of the vehicles coming from backside and alerts the user with visual and audio interactions.

## 2. Literature Survey and System Analysis

In the recent years many researchers focus on IoT based application. Jetendra Joshi & co [1] focused on functioning of the sensors and their correlation with alert system. Angelamartin et al [2] discussed about the calculation of suffocation level. Smit Grethiya Himanshu Agarwal & co [3] discussed the connection of the android components with the sensors. Neelam Sharma [4] discussed about the basic functionality of the CO<sub>2</sub> sensor and its working. The already existing system finds the solution of this problem by detecting the CO<sub>2</sub> level up to the suffocating mark using gas sensors. After the calculation of the CO<sub>2</sub> level, once after it reaches the peak level, the mechatronics are implied. The windows are automatically glided down. Though, this method proves to be effective, it fails when considering car safety without human intervention. The glass cabin is used here to achieve a volume constant of 30 x 30 x 30 cubic.cm. In the top of the glass tank, two holes are made where one for CO<sub>2</sub> sensor and the other one for CO<sub>2</sub> gas supply. The sensor senses the preset threshold level of CO<sub>2</sub> when air from the CO<sub>2</sub> tank exits the glass tank, and a digital signal is sent to the Arduino UNO PIN 8. Using the Arduino UNO compiler on the Machine Interface to program the Arduino UNO uploads via USB. The Arduino board sends the output digital signal to the L298N dual motor controller module - 2A after receiving the input signal from the sensor. DC motor is been controlled by a power window which establishes a connection between the. When the motor runs, the power window goes down and allows fresh air. The following components are attached to the breadboard - Arduino board, L298N dual motor controller module-2A, DC motor, CO<sub>2</sub> sensor. The permissible atmospheric CO<sub>2</sub> levels for human survival and the estimation of the CO<sub>2</sub> PPM level based on the chosen test space are determined by the following equation  $\% \text{Concentration} = \text{ppm} / 10,000$ . This existing system has some drawbacks that have to be concentrated and could be used for reference of a new system. 1. Lowering the window each and every time CO<sub>2</sub> decrease may seriously lead to potential security threat and issues. 2. Similarly, the permission from the particular user is not needed at this type of system. So, this may lead to genuineness problem. Even any type of gas in the car at high proportions may directly head to opening of windows which is inaccurate.

## 3. Proposed System

The proposed system provides the features of solving two main problems caused by the crash and non-crash related accidents. This type of system is one of the fastest growing

safety features in the automotive industry. Such a system allows vehicles to detect the possibility of collisions and to issue visual and audio alerts to the driver so that the driver can take the necessary steps to avoid collision. It also provides an efficient suffocation detection which can prevent the danger rates caused due to asphyxiation and manages to alert the user and surroundings. The implementation details are as follows: The project is combined with Arduino components, sensors and the alert system. The Arduino controller is connected with the two main sensors which plays the key role of the project . The CO2 Sensor (MQ135Gassensor) and the distance calculation sensor (Ultra sonic distance sensor) are connected with Arduino UNO. The threshold level of CO2 are kept as benchmark considering the information.



PPM LEVEL	EFFECTS IN HUMAN BODY
350to1100 ppm	Densities of indoor occupied spaces with good exchange of air
350to1000 ppm	Densities of occupied in door spaces with good air exchange
1000 to 2000ppm	They cause drowsiness and air pollution.
2000 to5000 ppm	Head ache, lethargy and drowsiness, old, bloated air. Low focus, lack of attention, elevated heart rate and even mild nausea can also be present.
5000 ppm	In most jurisdictions, Occupational exposure limit(as an 8-hour TWA)
>4000ppm	Major lack of oxygen results in severe brain injury, coma, and even death due to over exposure.

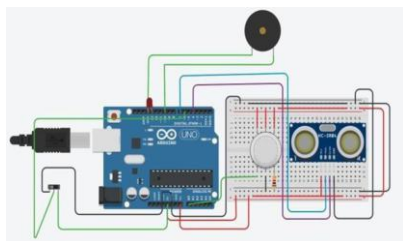
Figure 1. Working of Collision Management

The parts assembly as shown in the Arduino Uno is connected with the Co2 gas sensor and the ultrasonic sensor .Breadboard connects all the components on it acting as a base and power distributor. The car on and off are stated with the help of the switch. When the switch is off, the output from the CO2 sensor is verified, if the level reaches its peak the control is transferred to the buzzer .Similarly, when the switch is ON which states that the car is in working state, then it continuously detects the collision of objects from distance. Once the distance crosses the level, the driver is indicated with visual and audible interactions with the help of LED and buzzer. As the distance calculation is based on the ultrasonic sensor, it is important to know that the module has two eyes like projects in the front which forms the Ultrasonic transmitter and Receiver. The ultrasonic transmitter transmits an ultrasonic wave, this wave moves in air, and this reflected wave is detected by the Ultrasonic receiver as it gets opposed by some material it gets reflected back towards the sensor.

4. Discussion of Result

At a case , where the car is OFF the suffocation levels are detected very frequently and is compared with the peak level. Once it reaches, the peak level the control is taken by the alert system. At a case, where the car is ON the collision chances are detected very frequently by checking the distance with the minimum distance value. Once it crosses the minimum distance, the driver is notified with visual and audible warnings and alerts. The corresponding measurements and the outputs can be viewed by the user .





**Figure 2.** Circuit Diagram of Proposed System



**Figure 3.** User notification

## 5. Conclusion of the System

The intimation of someone being locked and is suffocated in the car can be efficiently done without any regrets. In the emergency cases, user has an optional choice of sending this particular notification to the police or anyone of his choice whom he could trust. With positive test results, the In-Car Suffocating Prevention Framework can be successfully implemented as it can detect a person inside a parked car. Human lives can be saved within a 30-minute cycle as this avoidance device warns the owner to check for any defective purpose due to his or her carelessness. In order to identify humans, the device uses a very simple automation technique where feature extraction of a human presence is analyzed. By doing this, after being left alone for a certain amount of time for some reason, the device will help avoid child or pet death inside a vehicle. Similarly this could be the best efficient solution to alert the driver from all the distractions by checking the colliding objects. During such critical cases, this technique proves to be effective and easy to save lives. It enhances protection without any human intervention inside the vehicle.

## References

- [1] Jetendra Joshi , Vehicle and Passenger protection through cooperative sensor based Vehicular Networking , 2017 IEEE 4th International conference on smart Instrumentation Conference on Smart Instrumentation, Measurement and Application.
- [2] Ambeth Kumar.V.D, G.Saranya , D.Elangovan, V.RahulChiranjeevi, V.D.Ashok Kumar.IOT Based Smart Museum Using Wearable Device.Lecture Notes in Networks and Systems, Vol.55, pp: 33-42, 2018
- [3] Smit Grethiya Himanshu Agarwal,Shilpa Gite and Suresh V ,Affordable system for alerting ,monitoring and controlling heat stroke inside vehicles, at Industrial Instrumentation and Control (ICIC),2015.
- [4] Neelam Sharma and Anurag Tyagi, An IoT Approach for motion detection using Raspberry pi, International Conference on Intelligent Computing and Internet of Things (ICIT),2017.
- [5] Kids and car, 2016, Children death due heatstroke in car. :<http://www.kidsandcars.org/heatstroke.html>
- [6] National highway traffic safety administration. 2015, heatstroke death in car. Available from :<https://www.nhtsa.gov/heatstroke>
- [7] Liu C. (2001).US6263272.USA: Google Patents
- [8] Liu j. (2000).US6138068.USA: Google Patents

# Effective Early Stage Detection of COVID-19 Using Deep Learning

Swetha .M<sup>a,1</sup> and Rajendiran. M<sup>b</sup>

<sup>a</sup> PG Scholar, Dept of CSE, Panimalar Engineering College, Chennai, India

<sup>b</sup> Professor, Dept of CSE, Panimalar Engineering College, Chennai, India

**Abstract:** The Corona virus Disease 2019 (COVID-19), which was formerly called as 2019 Novel Corona Virus[1] is a breath taking disease. It had its impact on millions of lives across the world. At present, as of March 2021, the rate of infection has declined throughout different parts of the world [2]. But it has been warned by scientists that this deadly disease can have its second wave over a period of time. Also, there is a possibility of this covid-19 to become a seasonal disease [3]. In such case, premature diagnosis of this virus is essential in order to save many lives. A kit called RT- PCR has been employed to detect the presence of this virus [4]. However, this method of prognosis takes time depending on the locality of the infected person [5]. This leads to the proliferation of the infection. Hence, an alternate procedure should be unearthed, which diagnose this disease within a short span of time. In this paper, a Deep Learning concept has been proposed which aids the timely detection of the corona virus infection. This, inturn reduces the spreading rate of the infection and decreases mortality rate.

**Key words:** Covid-19, Diagnosis, RT-PCR, Deep Learning.

## 1. Introduction

The Novel Corona virus has its origin in the city of Wuhan, china [6], in December 2019. It is now rooted in different countries over globe and has been proclaimed as a pandemic. As of March 2021, 116 Million patients has been infected by the corona virus across the world, out of which 91 Million patients has been recovered from it and 2 million patients had lost their lives [7]. The cause of this infection is a SARS-Cov-2 virus, which has changing or mutating nature. This dynamic character of the virus makes it difficult for the researchers to find a vaccine for the infection. However, many countries like India found a vaccination for covid-19 after a long fight and it has been employed for public use [8]. It is believed that this vaccine has it efficiency of around 85% [9]. And there is no assurance that the vaccinated person will never get the infection again. The only way to decrease the size of infection is by diagnosing it early. Hence, we are in need of a sophisticated method for diagnosing the disease. Here comes the concept of Deep Learning, which enlighten the scientists for developing a new procedure for the diagnosis.

---

<sup>1</sup>Swetha. M, PG Scholar, Dept of CSE, Panimalar Engineering College, Chennai;  
E-mail: swetha@gmail.com

A substantial research has been done by many researchers on the usage of Deep Learning and Machine Learning in covid-19 detection [10]. Here, a Deep Learning concept which involves convolutional neural network has been put forth. The CNN is trained and tested with available covid datasets. When the input CT scan of the suspected patient is given to the CNN, it categorizes the data and detects the presence of infection. Once the presence of the virus is detected, the region which is affected by the virus can also be segmented by the network. This process can be done within a less amount of time with high performance.

## 2. Related Work

For the examination of the infection, many antigen kit has been employed around the world. But, it has been revealed that this tool has certain amount of negativity rate. To support this fact, an analysis has been made by analysts [11], which results in declaring the low performance of the procedure. In this experiment, 148 swabs were used, which gives of the sensitivity of 30.2 % . This shallow sensitivity proves that the antigen kit cannot be used as a main testing component.

In order to overcome the drawbacks of the toolkit diagnosis, many technical methods has been projected by different experimenters. These methods use CT scan of the patients, X- ray and ultrasounds of the lungs as input and diagnose the contamination. A review has been made which includes the use of ultrasound scan images of the lung as input [12] and gives the result . Here, it has been stated that the LUS method can be used for more accurate detection of pneumonia. Since it is of low cost, it can be performed anywhere, it can also be employed in the diagnosis of covid-19.

Another method, which involves the use of CXR for the identification of disease had been described by Rodolfo M. Pereira [13]. Even though, the use of CT scan is accepted worldwide for easy diagnosis of any disease, CXR can also be used for diagnosing many disease , particularly in case of covid-19, since it incurs less cost and can be processed with more speed. Here, it is employed to identify the pneumonia which is affected as a result of corona virus infection. This method is best suitable for unbalanced environment, which works by extracting the texture feature of the CXR.

Shayan Hassantabar[14] proposed a Deep Learning method of using x-ray image of the lung to identify the presence of corona virus infection. Here, two concepts has been used such as Deep Neural Network (DNN) and Convolutional Neural Network (CNN). The features of the image are extracted using the fractal technique and fed to DNN whereas direct lung image has been given as input to the CNN. After the experiment , it has been stated that the DNN has the efficiency of 83% where the CNN has the accuracy of 93%.

Apart from using CT images, x-rays and ultrasound images, covid-19 can also be detected using clinical data from the patients [15]. These clinical data includes the age of the patient, symptoms of the patients, persistence of the symptoms, food intake of the patients etc. In this system, many algorithms such as logistic regression, SVM, Decision Trees, Naïve Bayes has been employed to process the clinical data of 212 suspected patients. This obtained an overall accuracy of around 95% , however it may degrade with the increase of data.

### 3. System Architecture

The following diagram depicts the architecture of the proposed system. At first, the CT scan input is pre- processed in order to remove any noise and the features of the image are extracted and given as input to the CNN. Simultaneously, clinical data from the patients are collected, processed for the information and given as another input to the CNN. By processing these two inputs, the CNN with the utilization of the trained data, provides the result as positive or negative. If the result is positive, then the system further refines the infection affected region.

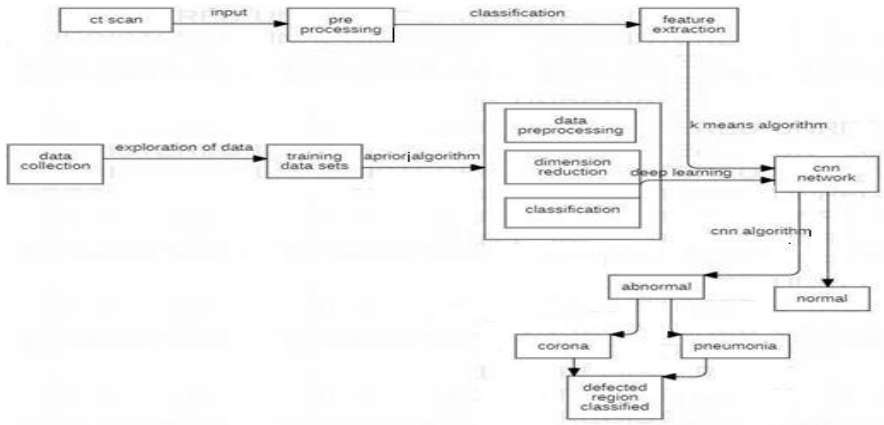


Figure 1. Architecture of the proposed system

### 4. Data Flow Diagram

#### 4.1. Data Flow Diagram 0

Collect the datasets from the healthcare centres or from any reputational website. Pre-process the data to clear any distractions.

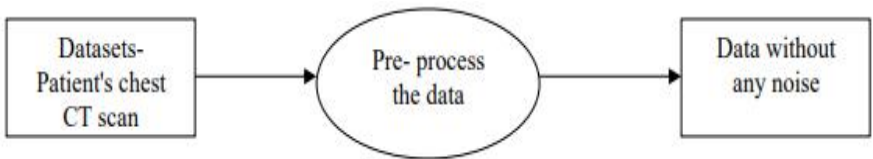
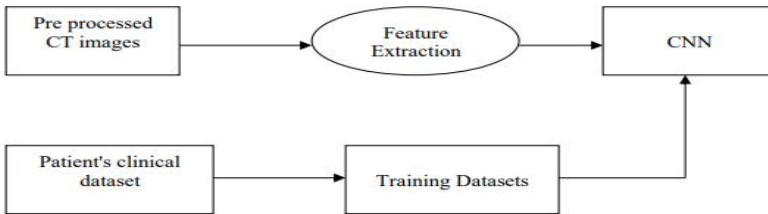


Figure 2. Data Flow diagram Level-0

#### 4.2. Data Flow Diagram 1

Characteristics are extracted from the pre-processed datasets and fed into the convolutional neural network. Simultaneously, physical data of the infected person is collected and trained and given as input to the CNN.



**Figure 3.** Data Flow Diagram Level-1

### 5. Result And Discussion

In the proposed system, we are using more than 6000 datasets for training and testing the CNN. When an input image along with the clinical data is given to the system, it produces the output with the efficiency if 97%.

### 6. Conclusion

Since COVID-19 is an extraordinary pandemic that undermines the whole world and wellbeing laborers are attempting to distinguish the manifestations because of the shifted indications appeared by different tainted patients, the utilization of innovation can help them in managing the pandemic. It is seen that Artificial Intelligence assumes a significant part in different applications including the clinical field. All these AI based methods has its own constraints, for example, not separating the Coronavirus sore from pneumonia injuries , absence of more crown tainted patient's datasets, inferior quality of the accessible datasets , inaccessible of the clinical information of the patients and so on. All of these requirements must be vanquished or cleared so as to build the adequacy of conclusion of the disease.

### References

- [1] World Health Organization's announcement [https://www.who.int/emergencies/diseases/novel-coronavirus-2019/technical-guidance/naming-the-coronavirus-disease-\(covid-2019\)-and-the-virus-that-causes-it](https://www.who.int/emergencies/diseases/novel-coronavirus-2019/technical-guidance/naming-the-coronavirus-disease-(covid-2019)-and-the-virus-that-causes-it)
- [2] <https://github.com/CSSEGISandData/COVID-19>
- [3] Livemint article - <https://www.livemint.com/science/news/coronavirus-likely-to-become-a-seasonal-disease-say-scientists-11600494712164.html>
- [4] COVID-19- Wikipedia [https://en.wikipedia.org/wiki/Coronavirus\\_disease\\_2019](https://en.wikipedia.org/wiki/Coronavirus_disease_2019)
- [5] CNET ARTICLE- <https://www.cnet.com/health/coronavirus-testing-how-long-does-it-take-to-get-test-results-for-covid-19/>
- [6] MedicalNewsToday Article- <https://www.medicalnewstoday.com/articles/coronavirus-causes>

- [7] Worldometer report - <https://www.worldometers.info/coronavirus/>
- [8] Vaccination Details- [https://www.mohfw.gov.in/covid\\_vaccination/vaccination/index.html](https://www.mohfw.gov.in/covid_vaccination/vaccination/index.html)
- [9] Indian Express Article - <https://indianexpress.com/article/explained/bharat-biotechs-covaxin-has-around-81-efficacy-what-does-this-mean-for-india-7212855/>
- [10] Swetha M. and Rajendiran M. - A Review on Effectiveness of Artificial Intelligence Techniques in the Detection of COVID-19/ DOI: 10.1109/SMART50582.2020.9336798.
- [11] Anaïs Scohy, Ahalieyah Anantharajah, Monique Bodéus, Benoît Kabamba-Mukadi, Alexia Verroken, Hector Rodriguez-Villalobos," Low performance of rapid antigen detection test as frontline testing for COVID-19 diagnosis – Journal of Clinical virology, Volume 129, August 2020, 104455
- [12] Natalia Budaa, Elena Segura-Graub, Jolanta Cylwik, Marcin Wehnickid, Lung ultrasound in the diagnosis of COVID-19 infection - A case series and review of the literature. - *Advances in Medical Sciences*, Volume 65, Issue 2, September 2020, Pages 378-385
- [13] Rodolfo M. Pereira, Diego Bertolini , Lucas O. Teixeira , Carlos N. Silla Jr. , Yandre M.G. Costa COVID-19 identification in chest X-ray images on flat and hierarchical classification scenarios / Volume 194, October 2020, 105532
- [14] ShayanHassantabara , Mohsen Ahmadi b , Abbas Sharific , Diagnosis and detection of infected tissue of COVID-19 patients based on lung x-ray image using convolutional neural network approaches / Volume 140, November 2020, 110170
- [15] AkibMohiUd Din Khanday Syed TanzeelRabani Qamar Rayees Khan Nusrat RoufMasaratMohiUd Din - Machine learning based approaches for detecting COVID-19 using clinical text data - <https://doi.org/10.1007/s41870-020-00495-9>
- [16] ShaopingHu,Yuan Gao, ZhangmingNiu, et al , Weakly Supervised Deep Learning for COVID-19 Infection Detection and Classification From CT Images, VOLUME 8, 2020, DOI - 10.1109/ACCESS.2020.3005510.
- [17] Xi Ouyang, JiayuHuoy, Liming Xia, et al, Dual-Sampling Attention Network for Diagnosis of COVID-19 from Community Acquired Pneumonia", DOI 10.1109/TMI.2020.2995508, IEEE Transactions On Medical Imaging.
- [18] Guotai Wang, Xinglong Liu, et al," A Noise-robust Framework for Automatic Segmentation of COVID-19 Pneumonia Lesions from CT Images , <http://dx.doi.org/10.1109/TMI.2020.3000314>
- [19] Longxi Zhou, Zhongxiao Li, Juexiao Zhou, et al, A Rapid, Accurate and Machine-Agnostic Segmentation and Quantification Method for CT-Based COVID-19 Diagnosis ", DOI 10.1109/TMI.2020.3001810
- [20] B.Akshaya, M.Rajendiran, “ Securing Documents Using Digital Certificate-A Review”, International Journal of Research in Advent Technology (IJRAT) , 2018
- [21] HengyuanKangy, Liming Xiay, FuhuaYany, et al , Diagnosis of Coronavirus Disease 2019 (COVID-19) with Structured Latent Multi-View Representation Learning",<http://dx.doi.org/10.1109/TMI.2020.2992546>
- [22] Mohamed Abd Elaziz , Ahmed A. Ewees, et al , An Improved Marine Predators Algorithm With Fuzzy Entropy for Multi-Level Thresholding: Real World Example of COVID-19 CT Image Segmentation, DOI 10.1109/ACCESS.2020.3007928
- [23] V.D.Ambeth Kumar, G.Gokul, S.Malathi, K.Vengatesan, D.Elangovan, B.Chitra, “Implementation Of The Pulse Rhythmic Rate For The Efficient Diagonising Of The Heart Beat”, , Healthcare Technology Letters (IET) 2019 Apr 17;6(2):48-52.
- [24] S.V. Ruphitha et.al, “ Management of Major Postpartum Haemorrhage by using Zigbee protocol - A Review “, 2021 6th International Conference on Inventive Computation Technologies (ICICT) (DOI: 10.1109/ICICT50816.2021.9358757 )
- [25] Ambeth Kumar.V.D, Dr.M.Ramakrishnan, V.D.Ashok Kumar and Dr.S.Malathi (2015) “Performance Improvement using an Automation System for Recognition of Multiple Parametric Features based on Human Footprint” kuwait journal of science, Vol 42, No 1 (2015), pp:109-132.
- [26] M.Ramakrishnan et.al., “Footprint Based Recognition System” in the month of April for the International Journal Communication in Computer and Information System (CCIS) Journal (Springer) Volume 147, Part 3, 358-367, DOI: 10.1007/978-3-642-20573-6\_63, April 2011
- [27] Indhumathi.M et.al , “Healthcare Management of Major Cardiovascular Disease-A review”, 2021 6th International Conference on Inventive Computation Technologies (ICICT), (DOI: 10.1109/ICICT50816.2021.9358519 )
- [28] Hema Kumar.S, J.Uday Kiran, V.D.AKumar, G.Saranya, Ramalakshmi V, “Effective Online Medical Appointment System”, International Journal of Scientific & Technology Research, Volume 8, Issue 09, September 2019, Pages 803 – 805.
- [29] Ambeth Kumar.V.D et.al .Novel Wireless Sensing System For The Welfare Of Sewer Laborers. Healthcare Technology Letters, Volume 5, Issue 4, pp. 107 –112, 2018

# IOT Based Weather Reporting System Using Arduino and Node MCU

Meera.S<sup>a,1</sup>, Sharmikha Sree.R<sup>b</sup>, Kalpana R.A<sup>c</sup>, S.R.Manasvini<sup>c</sup>, Haritha.V<sup>d</sup> and  
Dr. K. Valarmathi<sup>c</sup>

<sup>a,1</sup>Assistant Professor, Dept of CSE, Sri Sairam Engineering College, Chennai, India

<sup>b,C,d</sup>Student, Dept of CSE, Sri Sairam Engineering College, Chennai, India

<sup>c</sup>Professor, Dept of CSE, Panimalar Engineering College, Chennai, India

**Abstract:** Weather is an ever changing phenomenon. It can change in within seconds or milliseconds. Weather was quite difficult to monitor in the days when technology was still primitive. But now it is easy as there are various sensors and computing techniques to not only monitor weather but predict it with high accuracy as well. To simplify the detection process IOT (Internet of things) is employed in the project. As IOT is used Arduino is added to the project along with other sensor to monitor the weather. The data from the sensor is uploaded to an open source web-server. The open server can be used both to get real time data as well as download the data for the prediction process. Prediction is done using machine learning algorithms and training the detected datasets.

**Keyword:** IOT, Machine Learning, Weather, Arduino

## 1. Introduction

Weather reporting system is a monitoring system that displays and relays weather in the server to view. The server also acts a dataset collection center from where the data can be downloaded to feed into the machine learning algorithm. This system works as both a monitoring and predicting system. The technology used for monitoring is IOT i.e. Internet of Things. This incorporates sensors, Arduino and Node MCU Wi-Fi module ESP8622. The sensors detect the climatic changes which is as a data fed to Arduino and this data is inputted to the Node MCU which is then used as module to connect to the server and display the output. The server is open source server where the data can be seen as different feeds and also as a whole in a dashboard where all different feeds can be joined.

---

<sup>1</sup>Meera.S, Assistant Professor, Dept of CSE, Sri Sairam Engineering College, Chennai, India.  
E-mail: meera.cse@sairam.edu.in

## 2. Related work

There are various works in this field of study. The main reference of this project is from [1] where the author uses various sensors and Arduino to execute the project. This project also has lot of application from machine learning prediction methods mostly from [2] where the prediction of rainfall and other factors are predicted using multiple linear regression method. This uses target and test method to predict where in the target method historical datasets are fed to train it and in the test method recent datasets are fed to understand the accuracy and compare the output. The paper [3] uses Arduino UNO, temperature, humidity and CO sensors for detecting carbon monoxide emissions. This project detects the pollution.

In [4] the author uses ESP8266 Node MCU, Temperature, humidity sensor, Arduino UNO, soil moisture sensor to find good temperature for growth of plants and best soil temperature. In [5] the author uses Raspberry Pi, temperature, Humidity sensor PM concentration sensor, Air quality index sensor since the Raspberry Pi is costly and not used for low budget project Arduino is instead replaced in its place. In [6] the author uses API and server and sensors to create a smart alert system for reporting weather. The author uses Internet of things with Arduino and Raspberry pi to execute the project. In [7] the author has used two machine learning algorithms one is multi target regression model and another one is recurrent neural network model .using these two models they have predicted rainfall possibilities, temperature and humidity[8-15].

## 3. Proposed System Methodology

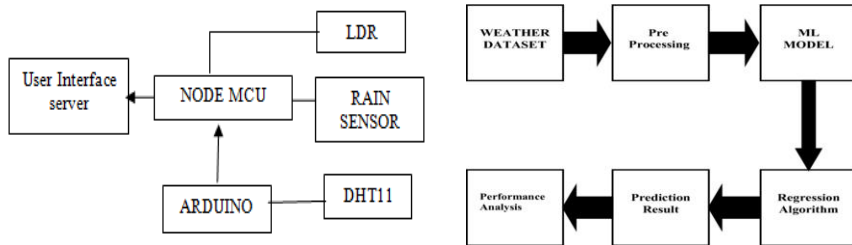
The proposed system contains various sensors, Arduino and Node MCU in a setup to read and show the data in sever. As the accuracy of the sensors are high the results obtained are also very accurate. The results are showed in the server by connecting Node MCU to the server. The server is open source and has various options to display the data individually in feeds or together in dashboards. The server also provides an option for downloading the data or feeding it directly into other programs.

### 3.1 Prediction using machine learning

1. The data is collected to feed into the system historical datasets are collected for the target system and the for the test system the datasets from the IOT sensors are used.
2. After the data is collected their features are identified.
3. The training and testing the algorithm is the next step in the process.
4. The training and testing of the datasets is done using multiple linear regression and multi target regression.



## 4. System architecture



**Figure 1.** (a) Weather reporting system IOT system architecture (b) Weather reporting system ML system architecture

### 4.1 Hardware components

#### 4.1.1 Arduino



**Figure 2.** Arduino UNO



**Figure 3.** Node MCU

Arduino is the base of the circuit diagram. Arduino is an open-source hardware and software board and board configuration software provided by the same company, It is used in the system to provide power and for data input. Arduino board designs use a variety of micro-processors and micro-controllers. They have series of analog and digital input and output pins. They also have a port to connect to the laptop for power and accessing the COM port for program loading and resetting process.

#### 4.1.2 Node MCU and DHT11

Node MCU is a low-cost open source IoT device .nodemcu has 16 general output input pins on its board.it has only one analog pin. EN &RST pins are the control pins for resetting the microcontroller. Vin pin is used for external power supply.3.3v power can be supplied to 3.3v pin to power the board. Nodemcu has four pins for SPI communication.



**Figure 4.** DHT11 sensor with 4 pins

Dht11 sensor has 4 pins while the dht11 module has 3pins.dht11 sensor and module works the same .but the only difference is, module has inbuilt filtering capacitor and pull up resistors, whereas for the sensor we have to use them externally if required .using dht11 sensor, we can measure temperature and humidity with an accuracy of  $\pm 1$  °C and % respectively.

### 4.1.3 LDR



Figure 5. LDR sensor light detector

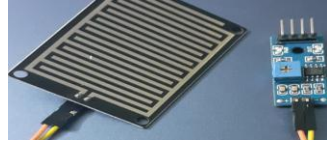


Figure 6. Raindrop sensor and controller

A Light Dependent Resistor also known as LDR is a device that are light-sensitive devices, whose resistivity is a function of the incident electromagnetic radiation. They are also called as photo conductive cells or simply photocells. They have high resistance and are made up of semiconductor materials. When it has low resistance it allows current to pass hence showing its dark and vice-versa.

### 4.1.4 Raindrop sensor

Raindrop Sensor is a tool used for sensing rain. It has 2 parts one detects analog input and another coverts it to digital. It has four pins, they are VCC, GND, D0, A0. D0 pin is the Digital pin.A0 is an Analog pin.

## 5. Result

### 5.1 Sensor implementation

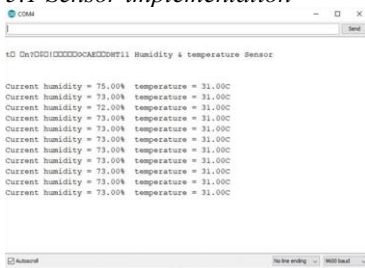


Figure 7. Implementation in Serial monitor of laptop server

### 5.2 Server implementation



Figure 8. Implementation in open source server

## 6. Conclusion

Thus this system deals with both prediction and monitoring of weather. The monitoring is done using Internet of things and prediction is carried out using machine learning

algorithm and methods such as multiple target regression. This method is very useful in prediction and so it helps in preparing for the future. Be it unexpected natural disaster or unexpected Ain this system helps in preparing early.

## References

- [1] Mohit Tiwari, Deepak Narang et al, Weather monitoring system using IOT and cloud computing., International journal of advanced science and technology ,June-2020.
- [2] Moulana Mohammed, Prediction Of Rainfall Using Machine Learning Techniques , International Journal of Scientific & Technology Research Volume 9, Issue 01, January 2020.
- [3] Girija C, Hashnalathan, et al, IOT based weather monitoring system, International Journal of engineering research and technology, Apr-2018
- [4] Devesh Kumar Srivastava ,IOT Based Weather Reporting System , International Journal of Engineering and Advanced Technology (IJEAT),Volume-9 Issue-5, June 2020.
- [5] Ferdian Joe John Joseph, IOT based weather monitoring system for effective analytics., International journal of engineering of and advanced technology APRIL-2019
- [6] Yashaswi rahat, Smart weather monitoring and real time alert system using IoT, International Research Journal of Engineering and Technology (IRJET) Volume: 05 Issue: 10 | Oct 2018.
- [7] Prathap N Kashyap, Intelligent Weather Forecasting using Machine Learning Techniques, International Research Journal of Engineering and Technology (IRJET )Volume: 07 Issue: 03 | Mar 2020.
- [8] Ramya,T.,Dr.Malathi,S.,ratheeksha,G.R. and Dr.V.D.Ambeth Kumar (2014)" Personalized authentication procedure for restricted web service access in mobile phones", Applications of Digital Information and Web Technologies (ICADIWT), 2014, Page(s):69 - 74, Bangalore, India (ISBN:978-1-4799-2258-1)
- [9] Ambeth Kumar.V.D (2018). Novel Wireless Sensing System For The Welfare Of Sewer Laborers. Healthcare Technology Letters (IET) Volume 5, Issue 4, p. 107 –112.
- [10] Ambeth Kumar.V.D, G.Saranya , D.Elangovan, V.RahulChiranjeevi, V.D.Ashok Kumar, "IOT Based Smart Museum Using Wearable Device", Lecture Notes in Networks and Systems, Vol.55, pp: 33-42, 2018
- [11] Ambeth Kumar.V.D and Dr.M.Ramakrishan(2011).Footprint Based Recognition System. in the month of April for the International Journal Communication in Computer and Information System (CCIS) Journal (Springer) Volume 147, Part 3, 358-367, DOI: 10.1007/978-3-642-20573-6\_63, April 2011.
- [12] Ambeth Kumar.V.D (2017), "Efficient Routing for Low Rate Wireless Network a Novel Approach", International Journal of Image Mining, Vol. 2, Nos. 3/4, 2017, 2017
- [13] Ambeth Kumar.V.D, V.D.Ashok Kumar, Dr.S.Malathi and P.Jagaeedesh, (2014) .Intruder Identification using Footprint Recognition with PCA and SVM Classifiers. for the International Journal of Advanced Materials Research Vols.1345, PP 984-985 (2014) pp 1345-1349. [DOI:10.4028/www.scientific.net/AMR.984-985.1345]
- [14] Ambeth Kumar.V.D, G.Gokul, S.Malathi, K.Vengatesan, D.Elangovan, B.Chitra .Implementation Of The Pulse Rhythmic Rate For The Efficient Diagonising Of The Heart Beat. Healthcare Technology Letters (IET) 2019 Apr 17;6(2):48-52.
- [15] Ruphitha.S.V et.al. Management of Major Postpartum Haemorrhage by using Zigbee protocol - A Review . 2021 6th International Conference on Inventive Computation Technologies (ICICT) (DOI: 10.1109/ICICT50816.2021.9358757 )

# Storage Optimization in Cloud Computing Using Discrete Firefly Algorithm to Minimize the Cost

Magesh Kumar S<sup>a,1</sup>, Ahmed MudassarAli<sup>b</sup>, Balasundaram A<sup>c</sup>, P J SathishKumar<sup>d</sup> and S Balaji<sup>d</sup>

<sup>a</sup>Associate Professor, Dept of CSE, Saveetha School of Engineering, SIMATS, Chennai, TamilNadu, India

<sup>b</sup>Professor, Dept of Information Technology, S.A.Engineering College, Chennai, India

<sup>c</sup>Assistant Professor, School of CSE, Center for Cyber Physical Systems, Vellore Institute of Technology (VIT), Chennai, India, TamilNadu, India

<sup>d</sup>Associate Professor, Dept of CSE, Panimalar Engineering College, Tamilnadu, India

**Abstract.** Abstract: Organizations incline to ruminant of data storage as an adjuvant service and do not elevate storage after data is stirred to the cloud. Many also fail to clean up unexploited storage and let these services run for days, weeks, and even months at imperative cost Proposed work offers a broad and foldable arrangement of information stockpiling decisions that move between various layers of capacity and change stockpiling types whenever. Our work likewise examines how to choose capacity benefits that meet information stockpiling wants at the most minimal expense and how to raise these administrations utilizing proposed discrete firefly algorithm to accomplish balance between concert, obtainability, and sturdiness. While basic storage arrangements could check the bytes and even de-duplicate information, they couldn't figure the business estimation of substance or the danger of losing data. Our Proposed work shows, our storage optimization analytics elucidation is facilitating creativities to better cognize their content and reduce storage expenditures by stirring the precise data to the cloud.

**Keywords.** Storage Optimization, Web Services, Object Storage, File Storage, Block Storage

## 1. Introduction

Nature has been a motivation for the presentation of numerous meta heuristic algorithms. It has figured out how to discover elucidation for issues without being told yet through experience. Common choice an natural selection was the fundamental inspiration driving the early metaheuristic algorithms. Various animals speak with one another through various method of interchanges. The light is created by a biochemical cycle called the bioluminescence. The blazing correspondence is utilized to draw in

---

<sup>1</sup>Magesh Kumar S, Associate Professor, Dept of CSE, Saveetha School of Engineering, SIMATS, Tamil Nadu, India.

Email: mmce6450@gmail.com

their mate and furthermore to caution hunters. In view of the example of the light, a reasonable mate will convey back by either mirroring a similar example or reacting with a particular example

## 2. Related Work

Introducing new algorithms has been one of the principle assessment zones [1]. As of now, there are more than 40 metaheuristic counts [2]. For instance, genetic method is moved by the Darwin theory of common determination [3]; atom swarm improvement is another metaheuristic computation reflecting how a huge number moves by following each other [4]; firefly count is propelled by how fireflies signal each other using the flashing light to attract for mating or to perceive trackers [5] and prey tracker estimation is another new figuring stirred by the lead of a tracker and its prey [6]. Various specialists utilized the idea of advancement in various applications, including designing applications, transportation arranging, the executive's applications, financial matters, computational knowledge, choice science, agribusiness, the travel industry, sport science and even political theory [7-18]. They predominantly utilized analytics based and iterative strategies. Maybe Fermat is the first to utilize a math based contention to tackle streamlining issues [19]. Iterative strategies were first proposed and utilized by Newton and Gauss [20]. Framework (Third Party [TP] or intermediary) implemented between the supplier and buyer to tackle the streamlining issues in cloud computing [21-27].

## 3. Proposed Work

### 3.1 Identify Data Storage Requirements

To advance stockpiling or storage, the initial step is to comprehend the presentation silhouette for every outstanding workload. Make to direct an exhibition examination to quantify input/yield activities every second (IOPS), throughput, and different factors. Transient information is brief and normally doesn't need high strength.

### 3.2 Storage Services

Picking the correct stockpiling service for information implies finding the nearest coordinate regarding information accessibility, solidness and execution. Proposed work deals three general classifications of capacity administrations: object, block, and file storage

### 3.3 Object storage

Amazon S3 is profoundly sturdy, universally useful object storage that functions admirably for unstructured informational collections, for example, media content. To the extent esteeming, the colder the data, the more affordable it is to store, and the costlier it is to get to when required.

### 3.4 Block storage

Amazon Elastic Block Store (Amazon EBS) sometimes give a strong square storage choice for utilize with EC2 occasions. Utilize Amazon EBS for information that needs long haul tirelessness and speedy right to use at ensured echelons of execution. Two kinds of square stockpiling exist here: Solid State-Drive (SSD) stockpiling and Hard Disk Drive (HDD) stockpiling.

### 3.5 File storage

Amazon Elastic File System (Amazon EFS) gives straightforward, adaptable record stockpiling for use with EC2 examples. Amazon EFS bolsters quite a few occasions simultaneously. Its stockpiling limit could scale from gigabytes to petabytes of information without expecting to arrangement stockpiling.

### 3.6 Enhance Storage

Amazon S3 allows to examine information access designs, make stock records, and arrange lifecycle strategies. Make set up guidelines to naturally move information objects to less expensive S3 stockpiling levels as items are gotten to less oftentimes or to consequently erase objects after a lapse date.

## 4. Proposed discrete firefly Algorithm for Storage Optimization

Firefly count is a large number based met heuristic calculation which was introduced by Yang. The proposed Firefly algorithm achieves Performance, Flexibility and durability and meanwhile it minimize the cost while comparing with EDFA (Effective Discrete Firefly Algorithm). Thus Firefly Algorithm is ideal choice to optimize the storage in Cloud Computing and it shows minimize the cost with respect to accuracy and speed factor.

```

Set Algorithm Parameters (N, MaxGen)
Set Simulation set-up (Number of Initial solutions and maximum iteration (N,
MaxGen))
Randomly Generate N Initial Solutions
For iter = 1:MaxGen
  Compute the brightness and Sort the solution in such a way that ,  $I_i \geq I_{i-1}$ ,  $i$ 
  For I = i:n-1
    For j=i+1:n
      If ( $I_j > I_i$ )
        Move firefly I towards firefly j
      Endif
    Endfor
  End for
  Move firefly N, (xb) randomly
End for

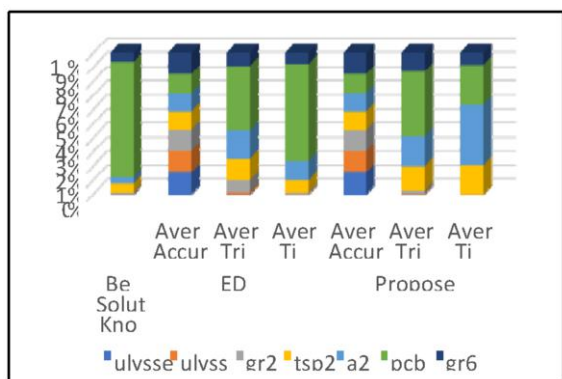
```

### 5. Performance Analysis and Experimental Results

The qualities for  $\alpha$ ,  $\beta$ , and  $\delta$  applied in this work are appeared in Table 1. Proposed DFA is inspected for 7 occurrences presented in Table 1 to contrast its presentation and EDFA proposed in Jati and Suyanto (2011). Here, Proposed DFA utilizes a populace size of 5 fireflies and the light ingestion coefficient is 0.001. For each of the seven occurrences, Proposed DFA runs a lot quicker than EDFA. Fig 1.shows comparison made between Proposed DFA and EDFA with respect to parameters Accuracy, Time and Speedup Factors applied so far.

**Table 1.** Parameters of FA

Parameters	Value
Fireflies ( $n$ )	10
Maximum number of iterations ( $t$ )	30
A	0.015
B	1
$\Delta$	0.95



**Figure 1.** Comparison of Proposed DFA with EDFA

### 6. Conclusion

Firefly algorithm is proficient and a simple to-execute procedure. It is additionally appropriate for equal usage. Moreover, the updates only depend upon current execution and no memory on past best game plans and presentations are kept. Thus Our Proposed Discrete Firefly Algorithm achieves better storage optimization comparing with EDFA with respect to speed factor and accuracy meanwhile minimize the cost. Moreover, the standard firefly calculation is intended for nonstop advancement issues; subsequently to utilize it for non-consistent issues it should be altered and changed.

## References

- [1] Encyclopædia Britannica: Firefly. In: Encyclopædia Britannica. Ultimate Reference Suite. Chicago: Encyclopædia Britannica (2009)
- [2] Babu, B.G., Kannan, M.: Lightning bugs. *Resonance* 7(9) (2002) 49–65
- [3] Fraga, H.: Firefly luminescence: A historical perspective and recent developments. *Journal of Photochemical & Photobiological Sciences* 7 (2008) 146–158
- [4] Lewis, S., Cratsley, C.: Flash signal evolution, mate choice, and predation in fireflies. *Annual Review of Entomology* 53 (2008) 293–321.
- [5] Leidenfrost, R., Elmenreich, W.: Establishing wireless time-triggered communication using a firefly clock synchronization approach. In: *Proceedings of the 2008 International Workshop on Intelligent Solutions in Embedded Systems*. (2008) 1–18
- [6] Jumadinova, J., Dasgupta, P.: Firefly-inspired synchronization for improved dynamic pricing in online markets. In: *Proceedings of the 2008 Second IEEE International Conference on SelfAdaptive and Self-Organizing Systems*. (2008) 403–412
- [7] Krishnanand, K., Ghose, D.: Glowworm swarm based optimization algorithm for multimodal functions with collective robotics applications. *Multiagent and Grid Systems* 2(3) (2006) 209–222
- [8] Yang, X.S.: *Nature-Inspired Metaheuristic Algorithms*. Luniver Press (2008)
- [9] Eberhart, R.C., Shi, Y.: *Computational Intelligence: Concepts to Implementations*. Morgan Kaufmann (2007)
- [10] Karaboga, D., Basturk, B.: A powerful and efficient algorithm for numerical function optimization: artificial bee colony (ABC) algorithm. *Journal of Global Optimization* 39(3) (2007) 459–471
- [11] Kennedy, J., Eberhart, R.: Particle swarm optimization. In: *Neural Networks, 1995. Proceedings., IEEE International Conference on*. (1995) 1942–1948 vol.4
- [12] Schutte, J.F., Groenwold, A.A.: A study of global optimization using particle swarms. *Journal of Global Optimization* 31(1) (2005) 93–108
- [13] Ingber, L.: Adaptive simulated annealing (ASA): lessons learned. *Control & Cybernetics* 25(1) (1996) 33–55
- [14] Himmelblau, D.M.: *Applied Nonlinear Programming*. McGraw-Hill (1972)
- [15] Schwefel, H.P.: *Numerical Optimization of Computer Models*. John Wiley & Sons, Inc. (1981)
- [16] Eason, E.: A survey of global optimization techniques. Master's thesis, University of Louisville (1990)
- [17] M'uhlenbein, H., Schomisch, D., Born, J.: The Parallel Genetic Algorithm as Function Optimizer. *Parallel Computing* 17(6-7) (1991) 619–632
- [18] Griewank, A.: Generalized descent for global optimization. *Journal of Optimization Theory and Applications* 34 (1981) 11–39.
- [19] Rosenbrock, H.H.: *State-Space and Multivariable Theory*. Thomas Nelson & Sons Ltd (1970)
- [20] Neumaier, A.: Permutation function. [http://www.mat.univie.ac.at/~neum/glopt/my\\_problems.html](http://www.mat.univie.ac.at/~neum/glopt/my_problems.html)
- [21] Balasundaram Ananthakrishnan. An Efficient Approach for Load Balancing in Cloud Environment. *International Journal of Scientific & Engineering Research*, 6(4). (April 2015)
- [22] S.Magesh Kumar, S.Ashokkumar, A.Balasundaram, Providing Enhanced Resource Management Framework for Cloud Storage, *International Journal of Engineering and Advanced Technology (IJEAT)*, 9(4), October 2019.
- [23] Magesh Kumar, S. & Subramanian, S.S.. (2016). An improved solution for resource scheduling optimization by resource grouping method in cloud computing. 9. 41-48.
- [24] Magesh Kumar.S, S. Subramanian, E. Anbalagan (2015). Nature Inspired Metaheuristic Algorithm for Cloud Computing Disk Optimization using Bridge Framework. 10. 19436-19444.
- [25] Magesh Kumar.S, Balasundaram A Kothandaraman D, AuxiliaOsvin Nancy V, P. J. Sathish Kumar, Ashokkumar S , An approach to Secure Capacity Optimization using Cryptographic Hash Function and Data De-Duplication, *Proceedings of the Third International Conference on Intelligent Sustainable Systems [ICISS 2020]*
- [26] Magesh Kumar.S, V.AuxiliaOsvin Nancy, Balasundaram A, SeenaNaikKorra, Kothandaraman D, Sudarshan, Innovative Task Scheduling Algorithm in Cloud Computing, *ICRAEM 2020, IOP Conf. Series: Materials Science and Engineering* 981(2020) 022023
- [27] Kothandaraman D, Balasundaram A, SeenaNaikKorra, Sudarshan E and Vijaykumar B Enhancing dull images using discrete wavelet families and fuzzy, 2020 IOP Conf. Ser.: Mater. Sci. Eng. 981 pp. 022020



# Future Prediction of Cardiovascular Disease Using Deep Learning Technique

Indhumathi.M<sup>a,1</sup> and Dr.V.D.AmbethKumar<sup>b</sup>

<sup>a,1</sup>PG Scholar, Department of CSE, Panimalar Engineering College, Chennai, India

<sup>b</sup>Professor, Department of CSE, Panimalar Engineering College, Chennai, India

**Abstract.** Cardiovascular disease is the one of the most leading causes of death. Based on symptoms and risk factors the diagnosis of heart can be done. Predicting the cardiovascular disease in the early stage can save the human being. There is no complete cure which reduces the risk of CVD. Deep learning technique has been used to predict the CVD in a prior stage. Based on the symptoms and risk factors, the CVD has been classified into four types such as No heart disease and no symptoms, Structural Heart Disease without symptoms, Structural Heart Disease with Symptoms and the risk factor for Heart failure are “High blood pressure, high cholesterol, genetic, diabetes, obesity is the major risk factors” to identify the cardiovascular disease and current technique is used to control the risks. To manage all the risk factors Electrocardiography (ECG) method is used to manipulate based on particular situation.

**Keywords:** CVD, Healthcare, risk factors.

## 1. Introduction

An estimation done by World Health Organisation (WHO) in the year 2016 for the CVD patients is nearly about 17.9 million people. It is nearly 31%. Because of CVD the huge death occurs. The group of disorder of heart and blood vessels includes coronary heart disease, rheumatic heart disease and other conditions. Under the age of 70 years, one third of the death occurs because of heart attack and stroke. In an earlier stage it is very difficult to predict the CVD affected patients. Based on the symptoms and risk factors the CVD affected patients has been found out. Some of the risk factors like “high blood pressure, Diabetes, High blood Cholesterol, genetic and obesity. Some of the symptoms like pain in chest, shortness of breath, cold sweat and nausea and fatigue. Coronary heart disease, High blood pressure, Cardiac Arrest, Heart failure and Arrhythmia, Peripheral artery disease and stroke are the some of the types of heart disease.

---

<sup>1</sup>Indhumathi.M, Student, Department of CSE, Panimalar Engineering College, Chennai, India.  
E-mail: mindu1910@gmail.com

## 2. Related work

From the sudden increase of blood pressure with the development of acute decompensate heart failure (ADHF). Out of 3239, 113 patients were analyzed and produced the composite endpoint group and non-composite endpoint group. The cut-off value for composite endpoint was 8.65. Need more clinical study to confirm this result[1]. To find the correlation between TG/HDL-Cholesterol ratio with cardiac risk factors. Chi-square test was computed to check relation of cardio metabolic risk factors like hypertension, diabetes and obesity with TG/HDL-C ratio[2]. The best predictor in XG Boost model. They has been developed a highly precise prediction model for future hypertension [3]. For maintaining normal cardiac and metabolic status Natriuretic Peptides (NP) are important and have been used to predicts cardiovascular events. The three bioactive counterparts such as NTproANP, NTproBNP and NTproCNP were measured randomly in 348 samples. Oppositely extract relation were found among plasma NTproBNP or NTproANP[4].Administrative database has been used and the data has been divided into derivation and validation samples. Two-third has been used for derivation and remaining has been used for validation [5]. The epigenetic mechanism lies between cancer and cardiovascular disease and a small importance to burgeoning field of cardio-oncology[6].To assess the utility of Computed Tomography (CT) based abdominal aortic calcification for the prediction of LVDD and prognosis of asymptomatic pre-dialysis CKD patients[7]. Without using CT, MRI or other diagnostic equipment they predict the concomitant development of macroangiopathy in diabetic in a single clinical has been evaluated. The major limitation of this study is the author may have missed a macroangiopathydiagnosis[8]. For analyzing medical images the deep learning algorithm [10-32], in specific CNN is the most popular one. In DL the survey has taken from classification, segmentation and object detection[9].

## 3. System Architecture

Fig 1 represents the collection of patient's detail, in which it contains the blood pressure, cholesterol, genetic, diabetes and obesity, etc. After the collection of dataset, pre-processing has been done. Data pre-processing is transforming the raw data into an understandable format. After the data pre-processing, the data cleaning has been done. Data cleaning is the process of process of removing incorrect or duplicate data within the dataset.



**Figure 1.**Recognize Cardiovascular Disease using Deep Learning Technique

Training the models is said to be the data which should be trained and it is the initial set of data which is used to help a program understand how to apply deep learning techniques and produce sophisticated results. Testing the models is used to fit the model and testing data to test it and the generated models are to predict the results unknown which is said to be test set. The performance will be measured by using the test data only. The results will be collected for the two techniques which is used under the concept of convolution neural network and it will be compared to predict cardiovascular disease.

## 4. Dataflow Diagrams

### 4.1. Level 0

Collect a datasets from health care. Process the collected dataset and finding cardiovascular disease affected patients.

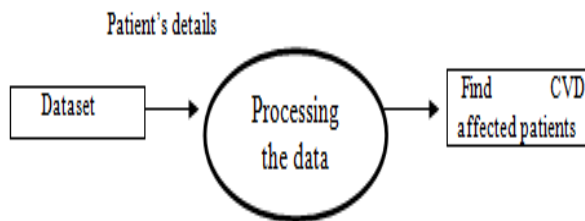


Figure 2. Level 0 DFD Diagram

### 4.2 Level 1

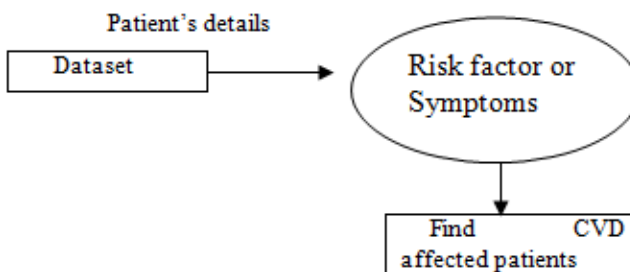


Figure 3. Level 1 DFD Diagram

## 5. Conclusion

In this paper, different attributes have been used and we can easily find the cardiovascular disease patients by analysing all the attributes. If the patient level goes abnormal, it makes sure to intimate the medical practitioner and the cardiovascular disease affected patients will be identified and prevented easily.

## References

- [1] Takahide Sano, Shunsuke Kiuchi, Shinji Hisatake, et al, Cardio-ankle vascular index predicts the 1-year prognosis of heart failure patients categorized in clinical scenario 1, *Heart and vessels*, May 2020
- [2] QuratulAin, Naveed Asif, Amir Alam, et al, Triglycerides-to-HDL Ratio as a Marker of Cardiac Disease and Vascular Risk Factors in Adults, *Department of Chemical Pathology & Endocrinology, Armed Forces Institute of Pathology (AFIP)*, vol 29(11) PP:1034-7, July 2019
- [3] Hiroshi Kanega, Kenji Suzuki, Kyohei, et al, Highly precise risk prediction model for new-onset hypertension using artificial intelligence techniques, *wileyonlinelibrary*, 2019
- [4] Timothy C. R. Prickett, Janet K. Spittlehouse, Allison L. Miller, Yusmiati Liau, et al, Contrasting signals of cardiovascular health among natriuretic peptides in subjects without heart disease, *scientific research*, August 2019
- [5] Husam Abdel-qadir, Paaladinesh Thavendiranathan, Peter C Austin, Douglas S Lee, et al, Development and validation of a multivariable prediction model for major adverse cardiovascular events after early stage breast cancer: a population-based cohort study, *European society of cardiology*, vol 40, PP 3913-3920, 2019
- [6] Abdalrahman Zarzour, Ha Won Kim, Neal L. Weintraub, Epigenetic Regulation of vascular disease, *ATVB in Focus Metabolic and oxidative stress*, April 1 2019
- [7] Kenji Furusawa, Kyosuke Takeshita, Susumu Suzuki, et al, Assessment of abdominal aortic calcification by computed tomography for prediction of latent left ventricular stiffness and future cardiovascular risk in pre-dialysis patients with chronic kidney disease: A single center cross-sectional study, *International journal of medical sciences*, vol. 16, 2019
- [8] Kiyohiko Takahashi, Midori Dannoura, et al, The association of cardio-ankle vascular index and ankle-brachial index with macroangiopathy in patients with Type 2 Diabetes Mellitus, *The official journal of the Japan Atherosclerosis society and the Asian Pacific society of Atherosclerosis and vascular Diseases*, vol. 26, PP 616-623, 2019
- [9] Geert Litjens\*, Thijs Kooi, Babak Ehteshami Bejnordi, Arnaud Arindra Adiyoso Setio, Francesco Ciompi, Mohsen Ghafoorian, Jeroen A.W.M. van der Laak, Bram van Ginneken, Clara I. Sánchez, "A survey on deep learning in medical image analysis", *Medical image analysis*, 2017
- [10] S.Hema Kumar, J.Uday Kiran, V.D.A.Kumar, G.Saranya, Ramalakshmi V, "Effective Online Medical Appointment System", *International Journal of Scientific & Technology Research*, Volume 8, Issue 09, September 2019, Pages 803 – 805.
- [11] Ambeth Kumar. V.D, Dr.M.Ramakrishnan, V.D.Ashok Kumar and Dr.S.Malathi (2015). Performance Improvement using an Automation System for Recognition of Multiple Parametric Features based on Human Footprint. *kuwait journal of science*, Vol 42, No 1 (2015), pp:109-132.
- [12] Ambeth Kumar.V.D, V.D.Ashok Kumar, S.Malathi, K.Vengatesan, M.Ramakrishnan. Facial Recognition System For Suspect Identification Using A Surveillance Camera. *Pattern Recognition and Image Analysis (Springer)*, Volume 28, Issue 3, pp 410–420, 2018. (DOI: 10.1134/S1054661818030136)
- [13] V.D.Ambeth Kumar and M.Ramakrishnan. Employment Of Footprint Recognition System. in the month of December for *Indian Journal of Computer Science and Engineering (IJCSE)* Vol. 3 No.6 Dec 2013
- [14] Ramya, T., Dr.Malathi, S., Ratheeksha, G.R. and Dr.V.D.Ambeth Kumar (2014). Personalized authentication procedure for restricted web service access in mobile phones. *Applications of Digital Information and Web Technologies (ICADIWT)*, 2014, Page(s):69 - 74, Bangalore, India (ISBN:978-1-4799-2258-1)
- [15] V.D.Ambeth Kumar (2018), "NOVEL WIRELESS SENSING SYSTEM FOR THE WELFARE OF SEWER LABORERS", *Healthcare Technology Letters (IET)* Volume 5, Issue 4, p. 107 – 112.

- [16] V.D.Ambeth Kumar, G.Saranya , D.Elangovan, V.RahulChiranjeevi, V.D.Ashok Kumar, "IOT Based Smart Museum Using Wearable Device", Lecture Notes in Networks and Systems, Vol.55, pp: 33-42, 2018
- [17] V.D.Ambeth Kumar and Dr.M.Ramakrishan(2011), "Footprint Based Recognition System" in the month of April for the International Journal Communication in Computer and Information System (CCIS) Journal (Springer) Volume 147, Part 3, 358-367, DOI: 10.1007/978-3-642-20573-6\_63, April 2011
- [18] V.D.Ambeth Kumar (2017), "Efficient Routing for Low Rate Wireless Network a Novel Approach", International Journal of Image Mining, Vol. 2, Nos. 3/4, 2017, 2017
- [19] V.D.Ambeth Kumar, V.D.Ashok Kumar, Dr.S.Malathi and P.Jagaeedesh, (2014) "Intruder Identification using Footprint Recognition with PCA and SVM Classifiers" for the International Journal of Advanced Materials Research Vols.1345, PP 984-985 (2014) pp 1345-1349. [DOI:10.4028/www.scientific.net/AMR.984-985.1345]
- [20] V.D.Ambeth Kumar, G.Gokul, S.Malathi, K.Vengatesan, D.Elangovan, B.Chitra, "Implementation Of The Pulse Rhythmic Rate For The Efficient Diagonising Of The Heart Beat", ", Healthcare Technology Letters (IET) 2019 Apr 17;6(2):48-52.
- [21] S.V. Ruphitha et.al, " Management of Major Postpartum Haemorrhage by using Zigbee protocol - A Review ", 2021 6th International Conference on Inventive Computation Technologies (ICICT) (DOI: 10.1109/ICICT50816.2021.9358757 )
- [22] M.Ramakrishan et.al., "Footprint Based Recognition System" in the month of April for the International Journal Communication in Computer and Information System (CCIS) Journal (Springer) Volume 147, Part 3, 358-367, DOI: 10.1007/978-3-642-20573-6\_63, April 2011
- [23] M. Indhumathi et.al , "Healthcare Management of Major Cardiovascular Disease-A review", 2021 6th International Conference on Inventive Computation Technologies (ICICT), (DOI: 10.1109/ICICT50816.2021.9358519 )
- [24] V.D.Ambeth Kumar, Dr.S.Malathi, V.D.Ashok Kumar (2015) "Performance Improvement Using an Automation System for Segmentation of Multiple Parametric Features Based on Human Footprint" for the Journal of Electrical Engineering & Technology (JEET) , vol. 10, no. 4, pp.1815-1821 , 2015. [http://dx.doi.org/10.5370/JEET.2015.10.4.1815]
- [25] Dr.V.D.Ambeth Kumar, S.Vaishali and B.Shweta (2015) "Basic Study of the Human Foot" for the Journal of Biomedical and Pharmacology, Volume 08 No. 01 Page No. 435-444 Jun, 2015.[DOI: 10.13005/bpj/632.]
- [26] V.D.Ambeth Kumar and M.Ramakrishan (2013) "A Comparative Study of Fuzzy Evolutionary Techniques for Footprint Recognition and Performance Improvement using Wavelet based Fuzzy Neural Network" for the International Journal of Computer Applications in Technology, Vol.48, No.2,pp.95 – 105, [DOI: ttp://dx.doi.org/10.1504/IJCAT.2013.056016]
- [27] Navadeepika K.M.R., Ambeth Kumar V.D. (2021) Enhancement in Braille Systems—A Survey", Advances in Intelligent Systems and Computing, vol 1257. Springer, Singapore. https://doi.org/10.1007/978-981-15-7907-3\_10.
- [28] V.D. Ambeth Kumar and S. Sharmila, "An Clinical Study on Finding Hypothermia and Postpartum Haemorrhage Using Temperature", International Journal of Psychosocial Rehabilitation, Vol. 24, Issue 05, pp: 2624- 2629, 2020.
- [29] Navadeepika.K.M.R, Dr.V.D.Ambeth Kumar, "Online Conversion of Tamil Language into Tactile for Visual Impaired People", International Journal of Advanced Science and Technology Vol. 29, No. 5, pp. 3401 - 3407, (2020).
- [30] A. Vignesh, T. YokeshSelvan, Ganesh Krishnan, Arjun N. Sasikumar, V. D. Ambeth Kumar, "Efficient Student Profession Prediction Using XGBoost Algorithm", Lecture Notes on Data Engineering and Communications Technologies, Volume 35, pp 140-148, 2020.
- [31] . HariKeshav, H. Divakar, R. Gokul, G. Senthil Kumar, V. D. Ambeth Kumar, "Real Time Categorical Availability of Blood Units in a Blood Bank Using IoT", Lecture Notes on Data Engineering and Communications Technologies, Volume 35, pp 503-510, 2020.
- [32] R. Christina Rini, V. D. Ambeth Kumar, "Cost Effective Decision Support Product for Finding the Postpartum Haemorrhage", Lecture Notes on Data Engineering and Communications Technologies, Volume 35, pp 649-656, 2020.

# Detection of Malicious Web Applications Using Machine Learning Algorithm

Sivagurunathan M<sup>a,1</sup>, Sivakumar<sup>P<sup>b</sup></sup> and Somasundaram. S K<sup>b</sup>

<sup>a</sup>PG Scholar, Department of Information Technology, PSG College of Technology, Coimbatore, Tamil Nadu, India

<sup>b</sup>Assistant Professor, Department of Information Technology, PSG College of Technology, Coimbatore, Tamil Nadu, India

**Abstract.** The emerging development of the internet everyone using web applications for their products or services. The large number of web applications created day by day. Since the demand is very high for web development, developers are creating an application not in a secure manner and hosting without the testing process. Web clients regularly store and oversee basic data that draws in cybercriminals who exploitation the web weaknesses for their benefits. Pernicious website pages are coming to pass undermining issue over the web on account of the reputation and their capacity to impact. Recognizing and examining them is exorbitant due to their characteristics and complexities. The complexities of assaults are expanding step by step in light of the fact that the assailants are utilizing mixed methodologies of different existing assaulting procedures. Using this opportunity attacker used their malicious script in their web application. Attacker, theft user's data, or redirect to malicious websites. In this project, we are proposing detection methods, to prevent the users from approaching the malicious web application. Using a Machine learning algorithm, extract the feature of the web application that is URL features and static features of the network. From the trained model of data set, using the Random forest algorithm detect the malicious web application.

**Keywords:** Features, Detection, Malicious URL, Machine Learning, Random Forest.

## 1. Introduction

The development in technology makes the internet grow faster than before. Every day the idea innovates by anyone. At the same time attacker also grow with same technology development. The applications of internet grow reflect everywhere. We are today, it is practically compulsory to have an online presence to run an effective business. The need of internet rapidly growing. Attacker also present in the rapid growth with new attack technique. It is difficult to plan strong frameworks to recognize network safety breaks.

---

<sup>1</sup>Sivagurunathan M, PG Scholar, Department of IT, PSG College of Technology, Coimbatore, India.  
E-Mail id: sivagurunathan.official@gmail.com

A Uniform Resource Locator, [1] known as a URL, is the worldwide location of archives and different assets on the World Wide Web. It is the tool utilized by programs to recover any distributed asset on the web. Fig 1 relating a piece of a URL is bolded to exhibit which part is being referred.



Figure 1. Parts of URL

A domain name is an interesting reference that differentiates a site on the World Wide Web. It comes straightforwardly after the protocol and is separated by a colon and two forward slashes. [2] The most popular attack methods are Social engineering and phishing methods and this happen by just visiting the malicious URL of the websites. These attacks happing without finding vulnerability in website, just force the user to click the given link by the attack. [3].Blacklist is basically an information base of URLs that have been declared to be malicious previously. This information base is assembled over the long run, as and when it becomes realized that a URL is malicious. [4] Those techniques are incredibly quick because of a basic inquiry overhead, and henceforth is extremely simple to implement. So, we need use the different algorithm for different attack techniques. [5]

## 2. Literature Survey

Anand Desai et.al, (2017) proposed, their point is to make an augmentation for Chrome which will go about as middleware between the clients and the harmful sites, and alleviate the danger of clients capitulating to such sites. Further, all hurtful content can't be comprehensively gathered as even that is bound to nonstop turn of events. [6]

Frank Vanhoenshoven et al (2016) used multiple algorithm technique Decision Trees, Random Forest, Naive Bayes, Multi-Layer Perceptron, Support Vector Machines and k-Nearest Neighbours. The mathematical reproductions have demonstrated that most characterization strategies accomplish worthy forecast rates without requiring either progressed highlight choice strategies. [7]

Anton Dan Gabrielet. al (2016) proposes that to present a system that analyzes URLs based on the network traffic and capable of adjusting its detection to new malicious content. Grouped URL is reused as a feature of another dataset that demonstrations as the spine for new recognition models.[8]

Guolin Tanet. al (2018), Unique in relation to the vast majority of past techniques, our work centres on finding vindictive URLs covered inside numerous kind hearted URLs in enormous organization traffic. In this paper, they assess the viability of our methodology on genuine datasets. [9]

Dongjie Liuet. Al (2016), to confirm the adequacy of the strategy, two distinct tests have been directed. To begin with, the proposed strategy was tried dependent on a developed complex dataset. They present correlation results between the proposed strategy and agent AI based recognition calculations. [10-13]

### 3. Proposed System

Fig 2 represents our proposed methodology, the first step of the implementation is getting the URL and feed in to the dataset. This data set explore and sanitize the URL. After that the URL is feed into real time feature controller that is extract the features from the URL. These features feed up into the classifier. Classifier, classify the necessary details. This detail used in decision trees. Each decision tree has the separate value of each feature. This decision trees combined and make the prediction based upon the score value.



Figure 2.Schematic Representation of Proposed Methodology

#### 3.1 Features Representation

Table 1 represents the lexical features of URL. This is static features of URL, without processing any network side of features. 15 Lexical features listed in table. From this table we can make different type of features trees, that is to predict the URL whether malicious or benign.

Table 2 represents the DNS features of URL, that is based on host-based network details. This can give the more number features to make the decision tree stronger.

Table 1.Lexical Features

Features	Type
Server	Real
Whois register	Real
Resolved IP count	Integer
Name server IP count	Integer
Name server IP count	Integer

Table 2. DNS features

Features	Type
Server	Real
Whois register	Real
Resolved IP count	Integer
Name server IP count	Integer
Name server IP count	Integer

### 4. Machine Learning Algorithm

Classification is considered as a light weight operation for analyse the URLs whether it is a malicious or non-malicious. Since though the crawling webpage method is considered as a most effective method in reality it come with the time as a cost. In our research we have used most random forest classifier for better classification. [8]



#### 4.1 Machine Learning

Machine learning classifier act as a teacher, which predict probability instance class based on the predefin features. Random forest classifier working based on decision tree nodes. Nodes will be used to find the URL as malicious or not. This decision tree combined together and score system will be calculate. [9,10].

#### 4.2 Flow of Algorithm

The algorithm working in the following way, the RAW file URLs dataset given as the input to the URL predictor. The RAW URLs get into the classifier that separates the URLs as the benign URL and malicious URL. The sanitized URLs are moved into machine learning algorithm that is Random Forest algorithm. This will create the different training data from the sanitized URLs. The training data called as feature extraction that is used for predicting the URL results. The extracted feature given into the training model, this will analysis the features weight and calculate the overall feature value. This value will result the final URLs prediction whether it is malicious or benign.

### 5. Experimental Results

This is in the form of 80/20 rule. That is initially dataset is divided into training dataset (80%), testing dataset (20%). In order to assess the most efficient mechanism to detect malicious accounts, we inspected various machine learning algorithm. Classifiers are the standard classifiers and widely used in solving problems. So, there are 450175 total numbers of URLs. From that, there is 345737 benign URLs and 104438 malicious URLs. Processed RAW file dataset used into classifier.

The processed dataset is given into classifier, classifier gives the good accuracy detection of malicious URL prediction rate is 98.2 %, the different types of algorithm with accuracy percentage 93.4% and 94.5% for Support Vector Machine and K-nearest Neighbour respectively.

Fig 3 is respective graph of different machine learning algorithm for malicious URL detection. Random forest algorithm gives the 98.2 % of result to the detection method. All types of features processed and the given URL link detected as malicious or benign with high accuracy.

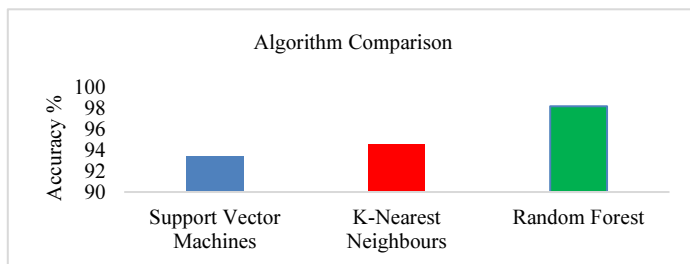


Figure 3. Comparison of Accuracy with proposed & existing Algorithm

## 6. Conclusion and Future Works

The proposed work analysis provides whether the URL is Malicious or not based on the URL features. The result of the detection method, based upon the decision tree. The algorithm has given a better output after increasing the number of features in the training data. This increases the accuracy of detection. The accuracy which is obtained at 98%, this result is better than the previous works. In future the detection method can be done using various types of new features that depends on exact value.

## Reference

- [1] Sayambar.A.B, A. M. Dixit, On URL Classification, International Journal of Computer Trends and Technology , 2014.
- [2] Merono-Peñuela.A, C. Guéret, R. Hoekstra, S. Schlobach et al., Detecting and reporting extensional concept drift in statistical linked data, in 1st International Workshop on Semantic Statistics (SemStats 2013), ISWC. CEUR, 2013.
- [3] Xiang et al., A Feature-Rich Machine Learning Framework for Detecting Phishing Web Sites, ACM Transactions on Information and System Security ,2011.
- [4] Luca Invernizzi, Paola MilaniComparetti, ,EvilSeed: A Guided Approach to Finding malicious Web Pages, Conference Paper, 2012 IEEE Symposium on Security and Privacy, DOI 10.1109/SP.2012.33.
- [5] D. R. Patil, J. B. Patil, Survey on Malicious Web Pages Detection Techniques, Science and Technology, 2015 International Journal of u and e- Service.
- [6] Anand Desai, JanviJatakia, RohitNaik and Nataasha Raul, 2017, Malicious Web Content Detection Using Machine Learning, 2nd IEEE International Conference on Recent Trends in Electronics Information & Communication Technology.
- [7] Frank Vanhoenshoven, Gonzalo N´apoles, Rafael Falcon, KoenVanhoof and Mario K¨oppen, 2016, Detecting Malicious Urls Using Machine Learning Techniques, IEEE Symposium Series on Computational Intelligence.
- [8] Anton Dan Gabriel, Dragos, TeodorGavrilit, B´aetuIoanAlexandru, Popescu Adrian S and tefan, 2016, Detecting Malicious Urls. A Semi-Supervised Machine Learning System Approach, 18thIEEE International Symposium.
- [9] Guolin Tan, Peng Zhang, Qingyun Liu, Xinran Liu, Chungu Zhu and Fenghu Dou, 2018, Adaptive Malicious Url Detection: Learning In The Presence Of Concept Drifts, 17th IEEE International Conference On Trust, Security And Privacy In Computing And Communications/ 12th IEEE International Conference On Big Data Science And Engineering.
- [10] Dongjie Liu and Jong-Hyouk Lee, 2016, Cnn Based Malicious Website Detectionby Invalidating Multiple Web Spams, IEEE access
- [11] Ramya,T.,Dr.Malathi,S.,ratheeksha,G.R. and Dr.V.D.Ambeth Kumar (2014). Personalized authentication procedure for restricted web service access in mobile phones.Applications of Digital Information and Web Technologies (ICADIWT), 2014, Page(s):69 - 74, Bangalore, India (ISBN:978-1-4799-2258-1)
- [12] Ambeth Kumar.V.D (2017).Efficient Routing for Low Rate Wireless Network a Novel Approach. International Journal of Image Mining, Vol. 2, Nos. 3/4, 2017, 2017
- [13] Arul E. et.al. (2021) Firmware Injection Detection on IoT Devices Using Deep Random Forest. In: Senjyu T., Mahalle P.N., Perumal T., Joshi A. (eds) Information and Communication Technology for Intelligent Systems. ICSSITIS 2020. Smart Innovation, Systems and Technologies, vol 195. Springer, Singapore. [https://doi.org/10.1007/978-981-15-7078-0\\_52](https://doi.org/10.1007/978-981-15-7078-0_52)

# Story-Telling for Children in Image Processing Using Deep Learning - A Survey Review

P.Haritha<sup>a,1</sup>, S.Vimala<sup>b</sup> and S.Malathi<sup>b</sup>

<sup>a,b</sup>Dept of CSE, Panimalar Engineering College, Chennai, India

**Abstract.** In this paper, a natural approach of the describing for the kids which it is brought into use, by making the image engraving technique of Deep Learning into thought. The previous work opens the technique for a course semantic mix plan (CSF) to mine the specialist features to encode the image content through thought instrument. A CSF benefits by three sorts of visual thought semantics which including the thing level, picture level, and spatial thought features, in three-stage course way. In the viewpoint on the current structure, the model takes the moved picture given by the customer as the information and starts recording the image what a PC find in human standard language with point by point explicit presents in the image appropriately exhibiting the significance of picture captioning. This strategy can be applied to the field of youngster's tutoring to make them pattern of adapting also entrancing. Fundamentally, we facilitate thought instrument with three kinds of features to orchestrate the setting data about the photos from differentviewpoints.

**Keywords.** instinctive methodology , CSF, three stage course, cycle of learning, deep learning , pc

## 1. Introduction

Deep learning is Associate in Nursing AI work that mirrors the operations of the human cerebrum in strategy information to be used in examination objects, perceiving discourse, interpreting dialects, and making choices. Profound learning AI is all through a grasp to travel looking out though not human bearing, drawing from information that is each unstructured and unlabelled. Profound Learning could likewise be an AI method upheld neural organization designs with numerous layers of strategy units, that has been effectively applied to an expansive arrangement of issues among the zones of picture acknowledgment and correspondence procedure. Facial acknowledgment includes abuse registering to distinguish human appearances in pictures or recordings, consequently menstruation explicit facial attributes. This may

---

<sup>1</sup>haritha.P, dept of cse, panimalar engineering college ,chennai, india

E-mailid:haritha81997@gmail.com

epitomize the hole among eyes, thus the general places of the nose, jaw line and mouth. This information is consolidated to make a facial mark, or profile. Pundits of veil acknowledgment conjointly expect that this new innovation might be inclined to assortment of the indistinguishable traps as face acknowledgment. A few of the training datasets utilized for biometric distinguishing proof are overwhelmed by Caucasian individuals. In the AI model, Convolutional Neural Network are created misuse Python, the CNN model is that the best fitted to picture data grouping. When the picture has been preprocessed by misuse A satisfactory apparatus, it will be served to the changed layers of the DCNN model. At spans the CNN model, there are quantities of covered up layers that is made of neurons.

## 2. Relatedwork

Najatsmeda, Eva Dakich, "The effectiveness of digital storytelling in the classrooms: a comprehensive study", 2017 Advanced narrating is one of the creative academic methodologies that can draw in understudies in profound and significant learning. This examination project meant to establish a constructivist learning climate with advanced narrating. The exploration examined the academic parts of computerized narrating and the effect of advanced narrating on understudy realizing when instructors and understudies utilize computerized stories.

2.1. *Jamshed Memon, Maira Sami, Rizwan Ahmed Khan, "Handwritten Optical Character Recognition (Ocr): A Comprehensive Systematic Literature Review (Slr)" 2020*

The goal of this survey paper is to sum up research that has been directed on character acknowledgment of manually written archives and to give research bearings. In this Systematic Li. They followed generally utilized electronic data sets by following pre-characterized survey convention. Articles were looked through utilizing catchphrases, forward reference looking furthermore, in reverse reference looking to look through every one of the articles identified with the subject. This survey article serves the motivation behind introducing cutting edge results and methods on OCR and furthermore give research bearings by featuring research holes.

2.2. *QIN WU, SIRUI WANG1, JIASHUO CAO1, "Object Recognition-Based Second Language Learning Educational Robot System for Chinese Preschool Children", 2018*

In this paper, an instructive robot framework with object acknowledgment innovation is presented, which plans to give creative second language learning administrations for preschool youngsters in China. The proposed framework joins object acknowledgment and projection with English instructing and makes objects in everyday life more intriguing with extended liveliness to stand out for children. On the projection screen, kids can cooperate with a robot by contact or development and can undoubtedly trigger more intelligent impacts. To assess the viability of the proposed framework, we directed a trial, and the outcomes showed that the framework can improve the language.

2.3. Vanessa Echeverria, "Towards data storytelling to support teaching and learning", 2017

They present a pilot study that investigates the viability of these DS components dependent on instructors' reactions to paper models. The double design is understanding the commitment of each visual component for information narrating, and the viability of the upgrades when joined. The outcomes recommend that DS components could add clearness, particularly when there are different potential stories in a mind bogglingspresentation.

2.4. Michael Paul C. Gutierrez, "Digital Storytelling vs Traditional Storytelling: Teaching English Language to ANHS Students", 2019

This paper will zero in on figuring out which kind of narrating will be more successful in showing English: customary or computerized. Customary narrating is the narrator audience approach, while advanced narrating is narrating utilizing PC based apparatuses. These two sorts of narrating were utilized to test the English capability of 2 distinct areas from the Adult Night High School (ANHS) understudies of La Salle Green Hills. Utilizing a pre-test acquired from the Word-Up project, the analysts had the option to evaluate their underlying English capability level. Subsequently, the understudies were approached to peruse the story 'The Monkey's Paw' by W.W Jacobs, one through customary perusing and the other through PowerPoint introduction.

3. Architecture

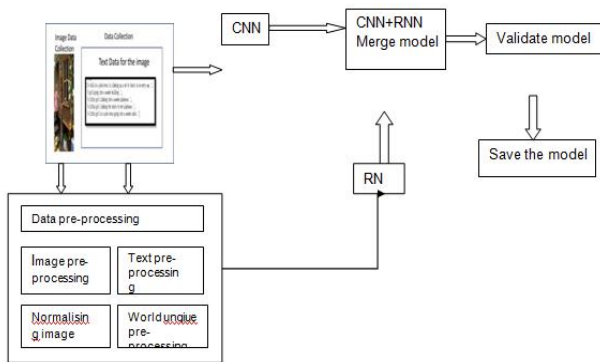


Figure 1. Story telling For kids architecture

In the current framework, the substance of the picture is encoded utilizing a few consideration methodology to remove the highlights. The structure is assembled utilizing Cascade Semantic Fusion engineering in a three phases: In the principal stage, object-level consideration highlights are removed dependent on the pre-prepared locator. In second stage consolidates object level consideration highlights with spatial highlights, along these lines instigating picture level consideration highlights to enhance the setting data around the items. In conclusive stage finds the striking locale portrayal making the thought more proficient.

### 4. Result AndDiscussion

Data Collection is the initial step in the process of evaluating the outcomes and the collected dataset is pre-processed to remove any noise or outliers if present. After completing data cleaning process the data will be Rescale and Discretize for next process.



Figure 2 .Output screenshot for the input image1

### 5. PerformanceAnalysis

The significance execution grid is a way to deal with focusing on which parts of execution ought to be dependent upon progress. In this system we get 92% of accuracy by training the dataset. Let us see the performance difference between existing system and proposed system in table 1:

Table 1.Performance analysis

<b>Existing method</b>	Data flicker(8k)	setEpoch 25	Accuracy 75
<b>Proposed method</b>	Data flicker(8k)	setEpoch 25	Accuracy 92

### 6. Conclusion

Datasets are a vital piece of the field of AI. The Major advances in this field can result from progresses in learning calculations, PC equipment, and, less-instinctively, the accessibility of top notch preparing datasets. When the model is stacked with the pictures given by the client, at that point the frame work begins in scribing accordingly shaping an account. An intriguing story can be acquired with the client inputted pictures. By putting hours of training for the proposed system 92% accuracy have been achieved. In each epoch, accuracy increase rate was very minimum. We have trained for nearly 8000 images with respective to the different image captioning. The proposed model for 92% its prediction for the image was fair.

## 7. Future goal

Narrating is an extraordinary social and social movement of offering stories to an expect to teach, engage, and impart virtues which are for the most part utilized in the social oral narrating occasions. Computerized narrating engages understudies to be sure communicators and makers of media as they acquire fundamental 21st-century proficiency abilities and arrive at more deep comprehension altogether zones of the educational plan. In future it will be used in education.

## References

- [1] Najatsmeda, Eva Dakich, The effectiveness of digital storytelling in the classrooms: a comprehensive study, 2017.
- [2] Jamshed Memon, Maira Sami, Rizwan Ahmed Khan. Handwritten Optical Character Recognition (OCR): A Comprehensive Systematic Literature Review (SLR) ,2020.
- [3] Qin Wu, Sirui Wang, Jiashuo Cao. Object Recognition-Based Second Language Learning Educational Robot System for Chinese Preschool Children .2018.
- [4] Vanessa Echeverria. Towards data storytelling to support teaching and learning .2017.
- [5] Akshaya.B, M.Rajendiran .Securing Documents Using Digital Certificate-A Review. International Journal of Research in Advent Technology (IJRAT). 2018.
- [6] S.Hema Kumar, J.UdayKiran, V.D.AKumar, G.Saranya, Ramalakshmi V .Effective Online Medical Appointment System. International Journal of Scientific & Technology Research. Volume 8. Issue 09. September 2019. Pages 803 – 805.
- [7] Ambeth Kumar.V.D, Dr.M.Ramakrishnan, V.D.Ashok Kumar and Dr.S.Malathi (2015) “Performance Improvement using an Automation System for Recognition of Multiple Parametric Features based on Human Footprint. kuwait journal of science . Vol 42, No 1 (2015). pp:109-132.
- [8] Ambeth Kumar.V.D, V.D.Ashok Kumar, S.Malathi, K.Vengatesan, M.Ramakrishnan. Facial Recognition System For Suspect Identification Using A Surveillance Camera .Pattern Recognition and Image Analysis (Springer), Volume 28, Issue 3, pp 410–420, 2018. (DOI: 10.1134/S1054661818030136)
- [9] Ambeth Kumar.V.D and M.Ramakrishan .Employment Of Footprint Recognition System. in the month of December for Indian Journal of Computer Science and Engineering (IJCSE) Vol. 3 No.6 Dec 2013
- [10] Ramya.T, Dr.Malathi,S.,ratheeksha,G.R. and Dr.V.D.Ambeth Kumar (2014). Personalized authentication procedure for restricted web service access in mobile phones. Applications of Digital Information and Web Technologies (ICADIWT), 2014, Page(s):69 - 74, Bangalore, India (ISBN:978-1-4799-2258-1)
- [11] Ambeth Kumar.V.D (2018). Novel Wireless Sensing System For The Welfare Of Sewer Laborers”, Healthcare Technology Letters (IET) Volume 5, Issue 4, p. 107 –112.
- [12] Ambeth Kumar.V.D, G.Saranya , D.Elangovan, V.RahulChiranjeevi, V.D.Ashok Kumar. IOT Based Smart Museum Using Wearable Device .Lecture Notes in Networks and Systems, Vol.55, pp: 33-42, 2018
- [13] Ambeth Kumar.V.D and Dr.M.Ramakrishan(2011). Footprint Based Recognition System. in the month of April for the International Journal Communication in Computer and Information System (CCIS) Journal (Springer) Volume 147, Part 3, 358-367, DOI: 10.1007/978-3-642-20573-6\_63, 2011
- [14] Ambeth Kumar.V.D (2017). Efficient Routing for Low Rate Wireless Network a Novel Approach. International Journal of Image Mining, Vol. 2, Nos. 3/4, 2017, 2017
- [15] Ambeth Kumar.V.D, V.D.Ashok Kumar, Dr.S.Malathi and P.Jagaeedesh, (2014) .Intruder Identification using Footprint Recognition with PCA and SVM Classifiers for the International Journal of Advanced Materials Research Vols.1345, PP 984-985 (2014) pp 1345-1349. [DOI:10.4028/www.scientific.net/AMR.984-985.1345]
- [16] Ambeth Kumar.V.D, G.Gokul, S.Malathi, K.Vengatesan, D.Elangovan, B.Chitra .Implementation Of The Pulse Rhythmic Rate For The Efficient Diagonising Of The Heart Beat . Healthcare Technology Letters (IET) 2019 Apr 17;6(2):48-52.
- [17] S.V. Ruphitha et.al, . Management of Major Postpartum Haemorrhage by using Zigbee protocol - A Review . 2021 6th International Conference on Inventive Computation Technologies (ICICT) (DOI: 10.1109/ICICT50816.2021.9358757 )

# Data Set Preparation Using the Method of Data Augmentation for Classification of Skin Diseases

AdlinLayola J.A<sup>a,1</sup> and V. MuraliBhaskharan<sup>b</sup>

<sup>a</sup>PG Student, Dept of CSE, Rajalakshmi Engineering College, Chennai, India

<sup>b</sup>Professor, Dept of CSE, Rajalakshmi Engineering College, Chennai, India

**Abstract.** Skin disease are mostly ignored and provided less importance at the early stages. Some ignorance among people might lead to skin cancer. In existing approach, the increased skin disease are identified at the later stage using biopsy only. The inspection is performed manually by considering many histopathological features. This paper explains the development of a model which helps to detect the various skin diseases at early stage using neural networks. For classification and prediction purpose this paper using Convolutional Neural Network. For improving the accuracy of prediction we are going to do dataset preparation. Data augmentation is using for increasing the count size of the training data. So that the accuracy of the classification will increase and will get 97% result.

**Keywords.** Skin Disease, Dataset Preprocessing, Data Augmentation, Deep Learning, CNN.

## 1. Introduction

Skin diseases are most common and difficult diseases for diagnosis because of its lack of awareness and ignorance. In many developing countries also people consult dermatologist for skin disease and prevention measures. Importance of skin disease without ignoring at the early stage is very important as skin plays a major role in protecting the human body against fungal and harmful bacterial infections. Many people get skin disease through their inheritance, job, lack of nutrition, regular habitats, exposed to chemicals etc. season, winter season. Thus identifying skin disease and diagnosis at the early stage is very crucial. To overcome this problem an application is identified and is used to predict the skin disease by using convolutional neural network. In this research, a classifier is created and which will produce different class for each skin disease.

---

<sup>1</sup> AdlinLayola J.A, PG Student, Dept of CSE, Rajalakshmi Engineering College, Chennai, India;  
E:mail:adlinlayola@gmail.com



The classes are generated by analyzing the input image and the image is compared matching with the previous training data. By this process, can improve the accuracy of prediction. This research is followed by HAM10000 dataset[1] which has approximately 10015 images of various skin diseases. The dataset is used by both testing and training phase. The dataset should be prepared for improving the accuracy. Increasing the training sample will give more accuracy so that the count size of the dataset is increased by data augmentation. The classifier using the augmented data set for prediction. Thus the result will show high accuracy. The following parts of this paper are arranged as follows: section 2 is a literature review, section 3 is the proposed method, section 4 is the results and discussion, and section 5 is the conclusion.

## 2. Literature survey

A review of existing research gives certain idea about this work. In [2] this paper describe the advantages of data augmentation. This paper explains the performance of classification improvement using data augmentation. In [3] proposed a approach for improving the age estimation using Convolutional Neural Network. Here the approach is evaluated for producing more accuracy by using data augmentation method. The results shows that the results were good when the classifier was trained with data augmentation. In [4] the training data set is expanded. Even after expanding the data set also the efficiency of deep convolutional neural networks will be improved. For experiment results they using PCA jittering, Noise,AN/WGAN, Rotation, Shifting, Flipping, Color jittering, Cropping data augmentation operations. This paper mainly discussed about the comparison of accuracy results for augmented and un augmented dataset. In [5] The additional samples are given by mapping elements from a different pool rather than from the dataset itself, according to a new data augmentation approach proposed. Cross-Dataset Data Augmentation was proposed and demonstrated successfully. In [6] compared and analyzed multiple operations of data augmentation. And new operation has been introduced which means image style transfer. In [7] evaluating the data augmentation in Charcoal Image Classification. This paper explores sub-images and morphological transformation as data augmentation approaches and produced 99.36% as average accuracy. In [8] exploits data augmentation approach in brain tumor examples and shows the boost up of generalization abilities of deep learning. In this approach, data augmentation techniques are applied to magnetic resources images and the advances were reviewed. In [9] focuses two data augmentation techniques which are oversampling and data warping. This survey gives different solutions for reducing the overfitting problem. In [10] build a deep learning study on skin disease image recognition.The review's finding is that data augmentation increases classification accuracy[11-13].

## 3. Proposed Methodologies

Methodology Our proposed system incorporates two technologies, they are dataset preparation and deep learning algorithm in which this model using convolutional neural network. Figure 1 shows the flow of classification of skin diseases followed by data

augmentation. The dataset was created using a dermatoscopic image of common pigmented skin diseases from Harvard's HAM (Human against Machine) dataset. Because of the unequal and scattered number of images in each class, we improved the dataset with the aid of data augmentation using Keras. Because of the difference in the number of images, we decided to build a dataset to improve the dataset's consistency, which will improve the model's accuracy. A large dataset is required for the CNN model to perform well, so high performance can be achieved by augmenting the available data. Data augmentation increases the size of the dataset, which improves the model's accuracy. Rotation, shearing, zooming, cropping, rotating, and adjusting the brightness level are examples of data augmentation operations. After augmentation the classification is done using convolutional neural network.

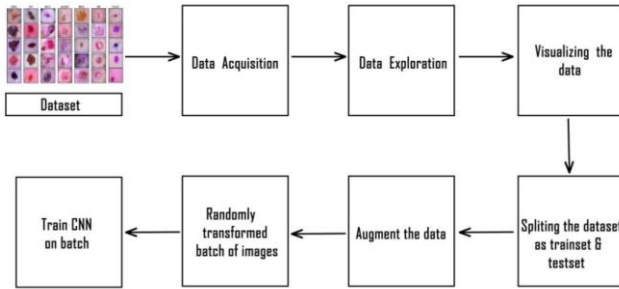


Figure 1. Flow diagram of skin disease classification followed by data augmentation

### 3.1 Dataset Collection

Skin disease dataset are collecting various images as a sample pictures. This paper has collected many skin infected image from various parts of the human body. In order to have more pictures of skin diseases, this paper is using HAM 10000 dataset which has seven different skin diseases which are vascular lesion(vas), benign keratosis lesions(bkl), melanoma(mel), actinic keratoses(akiec), melanocytic nevi(nv), dermatofibroma(df) and basal cell carcinoma(bcc). These are used for training and testing. Figure 2 displays different skin disease sample images of HAM10000 dataset.



Figure 2. Different skin disease sample images of HAM10000 dataset

### 3.2 Data Preparation

Keras Preprocessing means data preprocessing alongside the info augmentation module of the Keras deep learning library. This process includes the work along with image data, text data, and sequence data. Keras Preprocessing is compatible with Python 3.6. initially clearing the dataset of null values takes place. one-hot encoding is used in this process to convert categorical variables to numerical variables. Preprocessing technique is utilized before the deep learning algorithm, where in that all raw images are transformed and given to the classification. The training of the raw image on the convolutional neural network, leads poor performance of classification.

### 3.3 Augmentation of Data

The dataset which has been selected are made to be enlarged. If the process of increasing the training samples will result in more accuracy. HAM 10000 dataset consists of seven different classes of skin diseases. Among this only one class has maximum number of the sample images. According to that maximum number this paper explains, the method of augmenting the other classes of skin disease. As a result all the classes approximately consist of equal number of samples. For augmentation Brightness range, rotation range, zoom range, width shift range, horizontal flip, vertical flip, height shift range operations are used.

### 3.4 Classification and Prediction using CNN

Initially classifier has been created. Suppose an input image is given, preprocessing along with feature extraction takes place. These process are carried out in different layers. In the final layer it combines the extracted feature and represent it in the new model. Thus training the model, will predict the skin disease with high accuracy. Finally this paper ensures the accuracy with 97% approximately.

Results and discussion are described in the later stage. The model along with experimental approach is provided.

## 4. Results And Discussion

This paper explains the details about the classification of skin diseases followed by data set preparation using data augmentation technique.

### 4.1 Data Exploration

Data exploration is the process of visualizing the data from the dataset. Here we can see how many images are available in each classes with count sizes. Figure 3 explains the actual count size of the images in each classes.

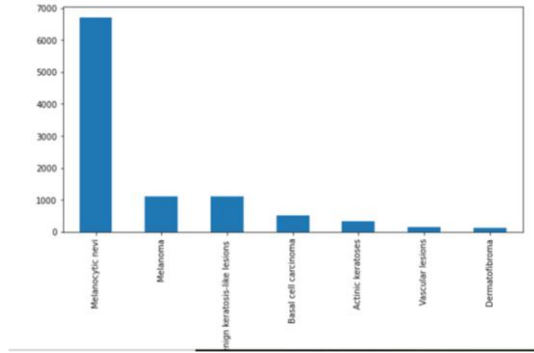


Figure 3. Actual count of images in each classes

### 4.2 Data Augmentation

For improving the accuracy of the classification have to increase the image count size of training sets. For this initially have to import the libraries. After that creating new directory for the images. Inside that base directory another new directories are created for training and testing of each classes. From the meta data have to divide the images as testing set or validation set and training set. Transfer the images to training and testing sets. Then augment the data using image data generator tool. Figure 4 shows the count size of training dataset after augmentation

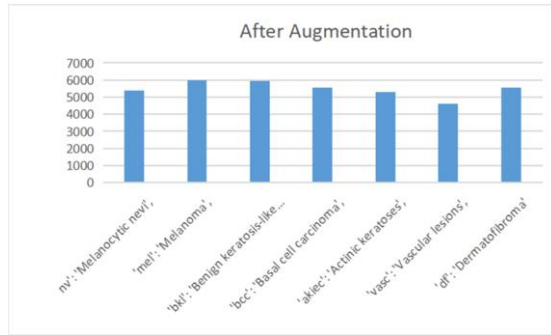


Figure 4. Increased count size of images in each classes after augmentation

We can also visualize the augmented images from the training dataset directory. Figure 5 shows some sample images of skin lesions which are augmented. Here, rotation, zoom, horizontal flip, vertical flip, height shift range, width shift range, brightness augmented operations are used.

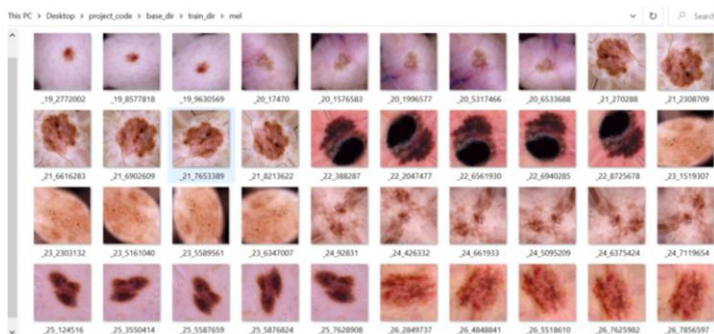


Figure 5. Sample images of skin lesions after augmentation

### 4.3 Classification

Finally classifier is created and the skin disease is predicted. Here using convolutional Neural Network is used for classification. And finally getting 99% accuracy results for predicting the skin disease by using data augmentation. Figure 6 represents the skin disease classification and prediction using the Convolutional Neural Network.

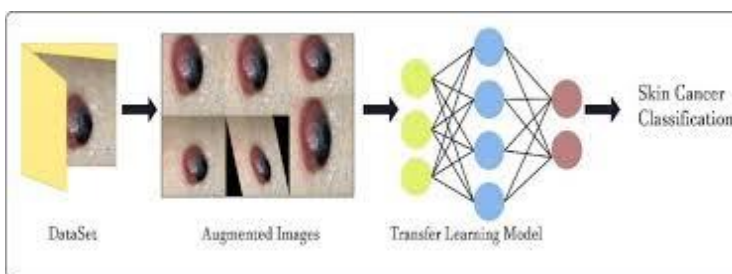


Figure 6. Classification process of skin diseases after data augmentation

## 5. Conclusion

After study and implementation of deep learning in the field of skin diseases it is concluded that Convolutional Neural Network while using data augmentation method provide very competitive results comparing to the state-of-the-art. The network is trained for the test of different skin diseases. After training the network was able to classify the skin cancer images into different classes. Forthis current work 99% accuracy was achieved with a CNN usage of data augmentation. Compared to previous works, this work uses more number of images in order to achieve better performance. Once improvements are made on the Classification deep learning algorithms for the skin disease in the field of medical the results can be improved. So nowadays deep learning is the best solution of skin diseases classification and recognition of cancerous diseases.

## References

- [1] Philipp Tschandl<sup>1</sup>, Cliff Rosendahl<sup>2</sup> &Harald Kittler(2018), The HAM10000 dataset, a large collection of multi-source dermatoscopic images of common pigmented skin lesions, [www.nature.com/scientific data](http://www.nature.com/scientific data), 5:180161.
- [2] Sebastien C. Wong,Adam Gatt, Victor Stamatescu and Mark D. McDonnell (2016), Understanding data augmentation for classification: when to warp?, Institute of Electrical and Electronics Engineers,
- [3] Italo de Pontes Oliveira, Joao Lucas Peixoto Medeiros, Vincius Fernandes de Sousa Adalberto Gomes Teixeira Junior, Eanes Torres Pereira, Herman Martins Gomes (2016), A Data Augmentation Methodology to Improve Age Estimation using Convolutional Neural Networks, 29th SIBGRAPI Conference on Graphics, Patterns and Images,2377-5416/16.
- [4] Shijie.J, W. Ping, J. Peiyi and H. Siping(2017), Research on data augmentation for image classification based on convolution neural networks, 2017 Chinese Automation Congress (CAC), Jinan, China, pp. 4165-4170.
- [5] Gasparetto.A et al.(2018), Cross-Dataset Data Augmentation for Convolutional Neural Networks Training, 2018 24th International Conference on Pattern Recognition (ICPR), Beijing, pp. 910-915.
- [6] Mikołajczyk.A and M. Grochowski(2018), Data augmentation for improving deep learning in image classification problem, 2018 International Interdisciplinary PhD Workshop (IIPhDW), Świnouście, Poland, pp. 117-122.
- [7] L. T. Menon, I. A. Laurensi, M. C. Penna, L. E. S. Oliveira and A. S. Britto(2019), Data Augmentation and Transfer Learning Applied to Charcoal Image Classification, 2019 International Conference on Systems, Signals and Image Processing (IWSSIP), Osijek, Croatia, pp. 69-74.
- [8] Nalepa, Jakub et al (2019), Data Augmentation for Brain-Tumor Segmentation: A Review, *Frontiers in computational neuroscience* vol. 13 83.
- [9] C. Khosla and B. S. Saini (2020). Enhancing Performance of Deep Learning Models with different Data Augmentation Techniques: A Survey, 2020 International Conference on Intelligent Engineering and Management (ICIEM), London, UK, pp. 79-85.
- [10] Ling-Fang Li, Xu Wang, Wei-Jian Hu, Neal n. Xiong, (Senior Member, Ieee), Yong-Xing Du, And Bao-Shan Li(2020).Deep Learning in Skin Disease Image Recognition: A Review. IEEE access, volume 8.
- [11] Ambeth Kumar V.D, Dr.M.Ramakrishnan, V.D.Ashok Kumar and Dr.S.Malathi (2015).Performance Improvement using an Automation System for Recognition of Multiple Parametric Features based on Human Footprint. *kuwait journal of science*, Vol 42, No 1 (2015), pp:109-132.
- [12] Ambeth Kumar.V.D, V.D.Ashok Kumar, S.Malathi, K.Vengatesan, M.Ramakrishnan .Facial Recognition System For Suspect Identification Using A Surveillance Camera . *Pattern Recognition And Image Analysis* (Springer), Volume 28, Issue 3, Pp 410–420, 2018. (DOI: 10.1134/S1054661818030136)
- [13] Ambeth Kumar.V.D and M.Ramakrishnan .Employment Of Footprint Recognition System. In *The Month Of December For Indian Journal Of Computer Science And Engineering (IJCSE)* Vol. 3 No.6 Dec 2013.

# A Review Based on Secure Banking Application Against Server Attacks

Revathy P<sup>a,1</sup> and Belshia Jebamalar G<sup>b</sup>

<sup>a</sup>Associate Professor, Dept of CSE, Rajalakshmi Engineering College, Chennai, India

<sup>b</sup>PG Student, Dept of CSE, Rajalakshmi Engineering College, Chennai, India

**Abstract.** In recent years, attacks on online based transaction become very common and are widespread, which makes the banking server compromised by using users account and personal information without authorization. To address the security concerns, also gain user trust and confidentiality, we propose automatic detecting and prevent bank attacks such as DDOS and SQL injection. Also, to eliminate bot-based attacks we enhance security at the authentication phase by invoking OTP thereby preventing brute force attack. The proposed system generates unique CAPTCHA for validating the user transaction. Hence it is difficult for intruder to perform unauthorized activities within the banking application. Finally, the proposed system secures user password from traditional approach using negative password generation technique. Thus, we conclude by combining all the three techniques together for the secured banking application.

**Keywords.** Distributed Denial of Service, SQL injection, Brute force attack and Negative password generation

## 1. Introduction

Cyber security plays an important role in financial sector. Mainly in banking since foundation of banking lies in trust, confidentiality and credibility. Its important role is to protect our sensitive and personal data. It also defends the entire network from the malicious customer assets. Nowadays especially during the covid times, more people go with cashless transaction so many fraudulent activities are done through online, as a result customer loses the trust in banks and other financial institutions here cyber security deals and resolves to give solution this problem by protection their data. This paper has taken two major attacks like DDOS and SQL injection. Denial of service means the attackers carefully craft the traffic to overload a firewall in an effective manner. Another method of overloading is that making all virtual machines sends dummy packets with no payload to the target firewall as the background traffic. Distributed Denial of Service (DDOS) is an attack which threatened the target system.

---

<sup>1</sup>Revathy P, Associate Professor, Dept of CSE, Rajalakshmi Engineering College, Chennai, India; E-mail: -revathy@gmail.com

It includes traffic like sending messages, fake packets and incoming calls by sending to server and network which they can't take control. Main purpose of this is to stop the legitimate user in utilizing the website. Sometimes it has tendency to divert the destination. When we focus on the target the cybercriminal takes this time to cheat us by installing malicious software or by stealing the data. This attack is mainly done on the servers and makes the transactions impossible. In this system we are trying to provide solution to all the attacks. SQL Injection (SQLi) is an attack which allows the attacker to inject the malicious query and possibly try all the ways to execute it. This has an ability to retrieve all the data from SQL database in order to exploit the customer personal and sensitive data. Database includes customer personal information, property details, trade secrets, transaction details and so on. If these details reach the fraud hands he can modify, insert, delete and anything might happen so this is considered to be most dangerous vulnerabilities of the banking application. It is really hard to prevent these vulnerabilities. The process actually begins with web page input and slowly reaches the query now the attacker starts to inject all malicious code which then automatically executed. It can even attack the network which is located behind. We also enhance our security to prevent brute force attack. Mostly recent days brute force attack is done by bots so that has become bot-based attack. The process involves in predicting our passwords by number of trials. Trials include guessing and also fetch the combination to reach the actual passwords. This attack is an oldest attack but still it exists. The process involves cracking which mainly depends on the length and complexity. Sometimes our antivirus protects us from this attack if it is not available then our system is at higher risk. Once the password has been cracked then automatically all our personal data will reach the hackers hand which can result a great loss for the customer in the banking application. The objective of the project is to style and develop a secure application for banking which detects intrusion and prevent the application from all these attacks by providing solution which invokes CAPTCHA along with OTP generation added to that the new method called encrypted negative password generation technique has been introduced. Completely Automated Public Turing Test (CAPTCHA) is actually detects whether the user is human being or not. Bots are generally used for brute force attacks if the CAPTCHA is given the bot can't able to identify all those letters so bot may not be allowed to log in further. One Time Password (OTP) is a static password which can be used only once and can't be reused. It is used to authenticate which generates a unique numeric code for each and every transaction. Timing is always synchronized with these OTP in order to make the transaction safe and secured. OTP changes every 30 or 60 seconds, depending on how the time is configured with tokens. It is very common in online banking and purchase. Since OTP is unique it is extremely difficult for the hackers to predict it. This are send to the user phone through SMS or by push messages. OTP tokens are of software based and are difficult to predict or keep track by the hardware. Encrypted Negative Password technique (ENP) is a newly introduced password preserving technique. It receives the plain password from the user which is hashed via cryptographic hash function that is SHA 256. The obtained hashed password is converted into negative password which is again encrypted into the encrypted negative password using symmetric key algorithm (AES). This method is extremely difficult for the hacker to crack the password as a result they have a lot of complication to reach our sensitive data. This technique eliminates data breaches in the traditional existing approach. In this all these three techniques are merged in the single application. For experimental results, banking-based web application is developed using Java frameworks to integrate the proposed.



## 2. Related Works

Nancy Nainan, Sumaiya Thaseen and Himika Parmar (2012) proposed an authentication service that is based on image and of time synchronized OTP which helps the system to identify the legitimate user. The OTP is unique and can change after the regular interval but can't be utilized after the stipulated time. Venkata Krishna Reddy, G. Sowmya and D. Jamuna (2012) proposed a system which prevents brute force attack by blocking method. This paper ensures high security where hacker find difficulty in assessing the user accounts.

Videh Paliwal, B. C. Julme, Sukrut Badhe, Vikrant Bhise and Ninad Narayane (2014) proposed and explained SQL injection attack patterns and prevention algorithm against the SQL Injection Attack. This includes scheme namely static and dynamic phase. phase maintains anomaly pattern and all queries are checked in the static side. Alarm will indicate the new form of anomaly and those patterns will be generated in dynamic side.

Anand Pandey (2015) developed a combined schema which gives the idea to maintain the password for any system along with alphanumeric type. This makes user simple and they have no necessary to memorize the difficult passwords.

Chithra (2013) presented many available algorithms which have been used to prevent the internet services from the DDOS attack. Also describes the strength and weakness all the available algorithm. This helps to understand problem in better way and also help in analyzing the right algorithm to particular problem on DDOS treat. Dave, Konark Truptiben (2015) provide solution to the attacks. Here brute force attack is generally meant that hacker guesses the combination of numbers and letters to crack the actual one. Many people have tendency to forget and some are lazy so might use simple passwords and utilize the same for all. These people are highly at risk so this paper gives solution to that problem by defending against the hackers. Pooja, Monika (2016) proposed the techniques which actually detects and provide methods for preventing SQL injection. This includes malicious code which has been injected in the database. In this paper for prevention approach called negative tainting is used along with two modules. This paper will detect the malicious code before the execution. This paper also discusses about the types of SQL injections and their strength along with its weakness. Upendra Singh, Surabhi Agrawal (2017) introduced botnet which frequently launch the Distributed Denial-of-Service (DDOS) overwhelm which hides an "army" of compromised nodes in the network. The application layer can lead to the number of possibilities to conceal the malicious activities exploited by the botnet which is performed by the emergence of attacks. Rudresh Gurav, Leena Dabhade, Abhilash Kulkarni, Amar Agarwal, Rahul Chinchore (2018) introduced Coverage to deal with the relation between the personal data and password. Probabilistic Context-Free Grammars (PCFG) guesses and try to crack the password based on the information used. This attack is common both in online and in offline mode. S. Soundharya, K. Ravi Kumar (2018) described that Internet is broadly used in every viable field in the modern times. In this busy world the data in the database and also in the public can be attacked through various techniques. One of the techniques to attack the database is SQL Injection attack which involves the unauthorized access to the SQL queries and cause damage to the execution also steal all the data which are kept personally. This paper uses PHP for attacks and storing all data in the database and Java is considered as the host language. Wenjian Luo (2019) proposed an ENP

technique with higher security. Encrypted Negative Password technique (ENP) is a newly introduced password preserving technique. It receives the plain password from the user which is hashed via SHA 256 which is again encrypted via symmetric key algorithm. This method extremely difficult for the hacker to crack the password as a result they have a lot of complication to reach our sensitive data. SachinJadhav, Sana Jamadar, PoojaLande, Gayatri Mane (2019) proposed a secret word verification system. This system contains two phases namely registration and authentication phase. Instead of password they receive secret word from the client and apply hash function which then encrypted to encrypted negative password by utilizing the symmetric key calculation and multi emphasis encryption. Nice Mathew and Salwa P.B (2019) utilized the RSA algorithm for the final encryption in order to secure password. . It receives the plain password from the user again the encryption process is carried via the RSA algorithm for more protection.

PradeepKumar, Poornima, Subathra S, and Nivetha (2020) proposed the authentication technique despite of many security laws. The proposed system has high secure password storage where the plain password is hashed. Now obtained password is converted to negative later the negative form to encrypted negative password (ENP). it is extremely difficult for to crack the ENP. This resists the lookup table attack and protects the dictionary attack. Bibin Varghese, Jitty Merin Mathew and Smita C Thomas (2020) proposed the k-hidden algorithm since it has advantage that is more grained than the q-hidden algorithm also this paper explains that ENP and hashing password is insecure and are easy to crack. It says that p-hidden algorithm is limited so that they utilize k-hidden with q-1 parameter.

### 3. Conclusion

Thus with all these existing paper the conclusion proceeds by combining many attacks together with three level security of the application. Added to this system, the paper includes upload of the file with encryption and decryption with can be loaded on to the cloud. This paper provides a safe and secured application for the user since all the personal details can ruin their life once it reaches the wrong one but the prevention helps the user to be more safe and secured in the application.

### 4. Scope for Future

The Implementation of this project with combination of attacks is to be made as a hybrid model. This model can be used for other applications also. A common model should be adopted for implementing in the real server. An attempt is taken to combine SQL injection, DDOS and brute force attack together in the experiment.

### References

- [1] Himika Parmar, Nancy Nainan, Sumaiya Thaseen, Generation of Secure One Time Password based on Image Authentication, CS & IT-CSCP 2012
- [2] G. Sowmya, D. Jamuna, M. Venkata Krishna Reddy, Blocking Of Brute Force Attack, International Journal Of Engineering Research & Technology (IJERT) Volume 01, Issue 06 (August 2012).

- [3] G. Sowmya, D.Jamuna, M.Venkata Krishna Reddy, Blocking Of Brute Force Attack, International Journal Of Engineering Research & Technology (IJERT) Volume 01, Issue 06 (August 2012).
- [4] Pandey, Anand. (2015), Password Management Using OTP Authentication, International Journal of Advanced Research In Engineering Technology & Sciences. 2.101-105.
- [5] Chithra, S., and E. George Dharma Prakash Raj, Overview of DDOS algorithms: A survey, International Journal of Computer Science and Mobile Computing IJCSMC 2, no. 7 (2013): 207-213.
- [6] Dave, Konark Truptiben, Brute-force Attack Seeking but distressing, Int. J. Innov. Eng. Technol. Brute-force 2, no. 3 (2013):75-78.
- [7] Pooja, Monika, SQL Injection: Detection and Prevention Techniques, International Journal of Scientific & Engineering Research, Volume 7, Issue 12, December-2016 280 ISSN2229-5518.
- [8] Agrawal, Surabhi, and Upendra Singh, Prevention of SQL Injection Attack in Web Application with Host Language, (2017):1468-1470.
- [9] Rudresh Gurav, Leena Dabhade Mr. Abhilash Kulkarni, Amar Agarwal, Rahul Chinchore, Personal Information in Passwords and Its Security Implications, International Journal of Advance Research in Science and Engineering, vol.07, Issue.05, March 2018
- [10] S.Soundharya, K.RaviKumar, Botnet Detection Technique Using Denial of Service (DDOS) Attack Elliptic Curve Digital Signature (ECDSA) Algorithm, International Journal of Research in Advent Technology, Vol.6, No.8, August 2018
- [11] Luo, Wenjian, Yamin Hu, Hao Jiang, and Junteng Wang, Authentication by encrypted negative password, IEEE Transactions on Information Forensics and Security 14, no. 1 (2018):114-128.
- [12] Sachin Jadhav, Sana Jamadar, Pooja Lande, & Gayatri Mane. (2019), A Novel Authentication Framework Using Negative Password Method for Improving Security, Journal of Network Security Computer Networks, 5(1), 1-7.
- [13] Salwa, P. B., and Nice Mathew, Encrypted Negative Password Using RSA Algorithm, (2019).
- [14] Poornima S, Nivetha M, Pradeep Kumar M, Subathra S, Authentication by Encrypted Negative Password, International Journal Of Engineering Research & Technology (IJERT) RTICCT – 2020 (Volume 8 – Issue 12),
- [15] Mathew, Jitty Merin, Bibin Varghese, and Smita C. Thomas, Password Authentication Framework Based on Encrypted Negative Password, International Journal Of Innovative Science And Research Technology (IJISRT), Volume 5 - 2020, Issue 3
- [16] S.Hema Kumar, J.Uday Kiran, V.D.AKumar, G.Saranya, Ramalakshmi V. Effective Online Medical Appointment System. International Journal of Scientific & Technology Research, Volume 8, Issue 09, September 2019, Pages 803 – 805.
- [17] Ramya, T., Malathi, S., Ratheeksha, G.R. and V.D. Ambeth Kumar (2014). Personalized authentication procedure for restricted web service access in mobile phones. Applications of Digital Information and Web Technologies (ICADIWT), 2014, Page(s):69 - 74, Bangalore, India (ISBN:978-1-4799-2258-1)

# Attaining Cloud Security Solution Over Machine Learning Techniques

K.Muthulakshmi<sup>a,1</sup> and Dr.K.Valarmathi<sup>b</sup>

<sup>a</sup>Research scholar, Anna University, Chennai, India

<sup>b</sup>Associate Professor, Panimalar Engineering College, Chennai, India

<sup>c</sup>Professor, Dept of CSE, Panimalar Engineering College, Chennai, India

**Abstract.** Cloud computing provides physical and logical computation resource on demand for the set of service. Cloud environment reduce the infrastructure cost and easy to use without any extra burden. Cloud storage an access raised the several security issues like data privacy, access control, authentication, virtual machine security, web security etc., In one side hackers, breaches, cloud security issues and threats get expanded. But in another side many technologies are keep increased to secure cloud data. Technology may be cryptographic technique, anonymization technique, machine learning technique etc., In this paper we analyse cloud computing basics, models, machine learning technique and some security solution through machine learning technique such as support vector machine (SVM), K-Nearest Neighbour (KNN), Decision tree and Naïve Bayes classifier technique.

**Keyword.** Cloud, security, machine learning, SVM, KNN, Naïve Bayes.

## 1. Introduction

Cloud computing is one of the most influential and relatively new technologies in our lives. With this technology, you can access computer resources and facilities at any time [1]. The healthcare industry is constantly evolving and can provide information on future healthcare models. Businesses can use cloud technology to manage changes and issues. This healthy technology facilitates communication, cooperation and coordination with various health care providers [2][3]. This is a new digital technology model that is often used in the healthcare sector. It not only processes medical information, but also facilitates the sharing or exchange of medical information between different partners [4]. In the age of big data, comprehensive health information improves the performance of cloud networks, which improves not only infinite data but also their internet. In the field of health care, electronic health records (EHRs) face many challenges related to privacy and unauthorized access, but information security and security are one of the most important of these challenges [5][6].

---

<sup>1</sup>K.Muthulakshmi, Research Scholar, Dept of CSE, Anna University, Chennai, India.  
Email:muthulakshmi@gmail.com<sup>1</sup>

There are risks ranging from warehouse recovery attacks that affect the security and confidentiality of medical data to effective attacks on distributed denial of service (DDOS) [7]. A cyber-attack activated through a recovery plan has far more consequences than financial loss and violation of personal life. Current privacy policy is not sufficient to ensure proper e-health cloud computing. The greatest danger to medical records provided in the cloud is the internal attacks of individuals with company evidence, which is far worse and more dangerous than external attacks [8][9]. This study aims to provide an in-depth review of the strengths and weaknesses of health care in EHR attacks. EHR contains a lot of confidential and sensitive information that is different from patient information and financial information, which not only displays the patient's tactical information in the event of a leak, but also causes financial loss. [10].

## **2. Background study**

### *2.1 Cloud Computing*

Cloud computing is a technology which provide access to the shared resources like CPU, Hard disk, Network devices those resource automatically assigned with minimum administrative task. It delivers many computing services like Servers, Databases, Storage, Analytics Networking etc., cloud security is protect cloud data, application & infrastructure from threats.

### *2.2 Cloud Service Model*

*Cloud provide3 types of services.*

IAAS – Fundamental resources, physical M/C, Virtual storage are access though infrastructure as a service. It provides all services via server visualization. Customer can access resource of computing via administrature access to VM.PAAS – It provide deployment and development tool to develop runtime application administration task is taken care by cloud providers depending upon function of platform. The types may be application, stand alone, open platform and addon development.SAAS – It consider application as a service to the end users. It requires low deployment cost, less vendor, it provide more robust solution.

### *2.3 Cloud Security*

Cloud security contains set of contols, technologies, procedures and policies will work together to protect cloud based storage system. Cloud provider take care of cloud security delivery. Cloud data security is more important when we move our sensitive data towards cloud storage. Selecting right cloud security solution depending upon application is a major task.

### *2.4 Cloud Security Threats*

#### **1. Data loss / Leakage**

Data loss is the serious cloud security count nearly 69% organisation points. This issue data gets shared using public link.

## 2. Data Breaches

This threats is still number one ranking in the survey. It cause financial and reputational damage.

3. Misconfiguration and inadequate change control.

Accidently business data gets exposed via the cloud.

4. Lack of cloud security architecture and strategy

5. Insufficient identity, credit access and key management – Lack of credential and key management

6.Account Hijacking-The account may be hacked and data get steeled.

## 2.5 Machine Learning

Machine learning is a technique which progressively improve the model or set of task given. Some task are assigned to machine. The machine will learn from its experience by getting more experiment. The machine takes decision, prediction or forecasting based on set of input is given. Supervised learning is a machine learning method which trains the machine towards labelled data i.e known output. It has two categories.

Classification – a classification is used to classify depends on input parameter into one category

Regression – a regression is used to classify the input into output variable as real values.

Types of Supervised learning

1) Regression – It is a supervised learning technique which is used to find correlation between variables and continuous output variable. This technique is mainly used to predict whether using temperature or other factors and also predict market trends. Linear regression, Logistic regression, polynomial regression is different kind of regression technique.

2) Classification – It is a supervised learning technique which categorized the training input data. The out put category may be classes or group. Binary classifier, multi class classifier are types of classification.

3) KNN (K-Nearest-Neighbour) – It is a supervised learning technique which shows the available data. New data points are classified based on the nearest similar value. It is the most effective technique for larger dataset.

4) SVM (Support Vector Machine) – It is a popular supervised learning technique. SVM creates decision boundary best line called a hyper plane which is used to segregate categories of input variable into output category. SVM mainly used for text categorisation, face detection, image classification. There are two type of SVM. Linear SVM and Non-Linear SVM.

5) Naïve bayes classifier – It is a supervised learning technique based on Bayes theorem. It use probability to classify the object. Sentimental analysis, spam filter is popular example of naïve bayes classifier. There are three types of naïve bayes models, Gaussian, multinomial and bernouicalssifer. Unsupervised learning is a type of machine learning technique. It find the hidden pattern from the input data set. It is a model which trained using unlabelled dataset. It makes machine to think like a human. There is no training for the machine.

Clustering is the method used to group similar object. Analysis can be done for the clustered object.

Association – It is used to find similarity between two objects. Market basket analysis is the popular example of association.

### 3. Machine Learning Algorithm in Cloud Security

#### 3.1. SVM(Support Vector Machine)

Personal health care information and medical record are stored in cloud. The above field must give more concentration to protect and give security in the cloud. Support vector machine is a efficient method for data protection and image segmentation of medical record.

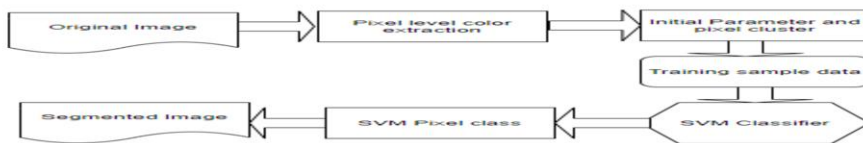


Figure 1: Support Vector Machine using pixel color extraction

The medical record original image gets extracted by using pixel color level. This extracted output is given to input of SVM for classification. It maximises prediction accuracy. SAAS –is a efficient model to give solution for health information technology. Medical data gets divided into pixel color. Cloud provider could not access medical data without owner knowledge[12].

#### 3.2 KNN- K-Nearest Neighbour

Data classification is the important procedure for giving cloud data security. Data classification must do proper information filtering with specific data sensitivity and requirements of security level. The data may be public, sensitive, non-sensitive, highly confidential etc., Traditional KNN has low proficiency in data filtration.

TsF – KNN (Training Set Filtration Key Nearest Neighbour) – Algorithm is integrating with KNN for data secured management procedure classification. TsF KNN is used to secure mobile cloud computing model and classify the data as public data or non-confidential data, highly confidential or top classified data. [13]

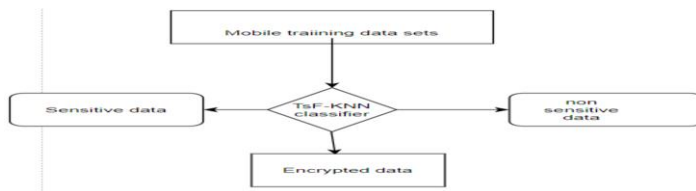


Figure 2: TsF-KNN

#### 3.3 Decision tree

Decision tree machine learning classifier technique are widely used in text classification, health care, remote diagnostic etc., Cloud service provider host decision

tree model to the cloud server. C4.5 algorithm mainly deal with noise and produce different decision tree. DT-TSVM (Decision Tree Twin Support Vector Machine) – Using this model encrypted training data set gets classified in secure manner.

### 3.4 Naïve Bayes Classifier

Medical data are stored in cloud. The data are trained by using Naïve Bayes classifier technique without leaking any patient record. Patient details should not leaked out during the disease diagnosis phase. The trained data from Naïve Bayes classifier is sent to cloud provider for storage. Some homomorphic cryptographic tools are used for secure aggregation of medical record[24].

## 4. Conclusion

In this paper we analyse and review the cloud security basic, threats, machine learning technique and cloud security solution through machine learning technique. Finally we conclude machine learning technique attract the academic scholar and play a important role in sensing threats and occurrences.

## References

- [1] Chadwick, D.W. and Fatema, K., A privacy preserving authorisation system for the cloud. *Journal of Computer and System Sciences*, 78(5), pp.1359-1373, 2012
- [2] Karadshesh, L., Applying security policies and service level agreement to IaaS service model to enhance security and transition. *computers & security*, 31(3), pp.315-326, 2012.
- [3] Suthar, K. and Patel, J., Encryscation: An secure approach for data security using encryption and obfuscation techniques for iaas and daas services in cloud environment. In *Proceedings of International Conference on Communication and Networks* (pp. 323-331). Springer, Singapore, 2017.
- [4] Liu, X., Zhang, Y., Wang, B. and Yan, J., Mona: Secure multi-owner data sharing for dynamic groups in the cloud. *IEEE transactions on parallel and distributed systems*, 24(6), pp.1182-1191, 2012.
- [5] Xu, H., Guo, S. and Chen, K., Building confidential and efficient query services in the cloud with rasp data perturbation. *IEEE transactions on knowledge and data engineering*, 26(2), pp.322-335, 2012.
- [6] Shen, Q., Liang, X., Shen, X., Lin, X. and Luo, H.Y., Exploiting geo-distributed clouds for a e-health monitoring system with minimum service delay and privacy preservation. *IEEE journal of biomedical and health informatics*, 18(2), pp.430-439, 2013.
- [7] Liu, H., Ning, H., Xiong, Q. and Yang, L.T., Shared authority based privacy-preserving authentication protocol in cloud computing. *IEEE Transactions on parallel and distributed systems*, 26(1), pp.241-251, 2014.
- [8] Zhou, J., Cao, Z., Dong, X. and Lin, X., PPDm: Privacy-preserving protocol for dynamic medical text mining and image feature extraction from secure data aggregation in cloud-assisted e-healthcare systems. *IEEE journal of selected topics in signal processing*, 9(7), pp.1332-1344, 2015.
- [9] Zhang, K., Liang, X., Baura, M., Lu, R. and Shen, X.S., PHDA: A priority based health data aggregation with privacy preservation for cloud assisted WBANs. *Information Sciences*, 284, pp.130-141, 2014.
- [10] Bahtiyar, Ş. and Çağlayan, M.U., Trust assessment of security for e-health systems. *Electronic Commerce Research and Applications*, 13(3), pp.164-177, 2014.
- [11] Marwan, Mbarek, Ali Kartit, and Hassan Ouahmane. "Security enhancement in healthcare cloud using machine learning." *Procedia Computer Science* , pp 388-397, 2018.
- [12] Inani, Anunaya, Chakradhar Verma, and Suvrat Jain. A machine learning algorithm TSF k-Nn based on automated data classification for securing mobile cloud computing model. *IEEE 4th International Conference on Computer and Communication Systems (ICCCS)*. IEEE, 2019.
- [13] Liu, Ximeng, et al. Privacy-preserving patient-centric clinical decision support system on naive Bayesian classification. *IEEE journal of biomedical and health informatics* pp. 655-668, 2018.



# Smart Shoe for Tracking and Monitoring of Army Soldiers

S Jessica Pauline<sup>a,1</sup>, Bharkavi A G<sup>b</sup>, Annlet Jesgna<sup>b</sup>, Maheswari S<sup>b</sup>  
<sup>a,1</sup>*UG Scholar, Dept of ECE, Panimalar Engineering College, Chennai, India*  
<sup>b</sup>*Professor, Dept of ECE, Panimalar Engineering College, Chennai, India*

**Abstract:** Presently in India, all sections of the defence system like army, navy and air force are facing an issue of tracking the soldier. At present, to know the status and location of each soldier, soldiers are communicated over radio line. But these methods are not effective for tracking. At the time of war, we always hear the problem of missing of soldiers in the newspaper. On focusing this problem, we have decided to develop a system that will automatically trace the location of each soldier. This paper utilizes long distance RF communication modules such as LoRa modules which provide long distance communication in terms of kilometres. As the military personnel moves around the city, the location of the military personnel is been transmitted to a nearby LoRa which is then transmitted to the mobile app developed independently for tracking the military personnel. Thus this paper will help in effectively tracking the military personnel.

**Keywords:** LoRa, RF communication, Tracking, Military personnel.

## 1. Introduction

In the existing system, in order to examine the execution of LoRa radios for industrial modernization both plain and energy gathering industrial territories are taken into account. The cost commutation inspection betwixt battery substitution and injury fine beside contrast sensing intervals which explains a direct rise in entire cost is the conclusion for these considerations taken into account. The work proposed a version to gauge the energy consumption, evaluating the battery span of LoRaWAN observing instruments. No practical communication in terms application is been implemented using the LoRa modules. This project utilizes long distance RF communication modules such as LoRa modules which provide long distance communication in terms of kilometres. The hardware component includes micro-controller, GPS, LoRa modules, etc. The hardware module is fixed to the shoes of the military personnel. As the military personnel moves around the city, th e location of the military personnel is been The hardware component includes micro- controller, GPS, LoRa modules, etc. The hardware module is fixed to the shoes of the military personnel. As the military personnel moves around the city, the location of the military personnel is been transmitted toa near LoRa which is then transmitted to mobile app developed independently for tracking the military personnel. Thus this paper will help in effectively tracking the military personnel. Cheap and effective solution for tracking the military personnel.

---

<sup>1</sup>Bharkavi A G, UG Scholar, Dept of ECE, Panimalar Engineering College, Chennai, India; Email: bharkavigopinath@gmail.com<sup>a</sup>

## 2. Related works

LoRa radio for industrial automation has been proposed by Hafiz Husnain Raza Sherazi et.al[1]. For the real time flows the assistance is given by LoRa. It describes a model to estimate the energy utilization, evaluating the battery period of LoRa WAN. RT-LoRa has been proposed by Luca Leonardi et.al[2], which offers assistance for real-time flows. The RT-LoRa gives some directions for the arrangement of an RT-LoRa network. To offer an individual electricity retail plan recommender system for domestic users, Fengji Luo et.al[3] has came up with service computing technique into the smart grid. The proposed personalized recommender system (PRS) is formed on the collaborative filtering (CF) technique. The smart meter first collects the user’s energy utilization data, and then it extracts the key energy utilization quality of user and reserves into a user knowledge database (UKD), along with the information of their chosen electricity retail plans. To reduce the power density shortage of current energy storage systems (ESSs) in pure electric vehicles (PEVs or EVs), a hybrid ESS (HESS), Chunhua Zheng et.al[4] has proposed a system, which contains a battery and a super-capacitor, is taken into account. The simulation results exhibit that the proposed strategy conserves electricity compared to the rule-based strategy and the single ESS case for the three driving cycles examined. A LoRa wireless network classification for electricity metering has been analysed by Mauricio C.Tom’e et.al[5], in which the technology along with a event-based metering strategy led to a great quality signal reconstruction [6-10].

### 2.1. Requirements

The hardware requirements include Power supply Unit, WiFi-module-ESP8266, AVR microcontroller, GPS module, LoRa Transmitter, LoRa Receiver. The software requirements include Visual Studio, CV AVR/ Arduino, Extreme burner, Android Studio working description

### 2.2. Block diagram

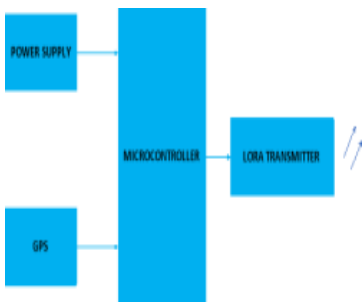


Figure 1. Transmitter Module

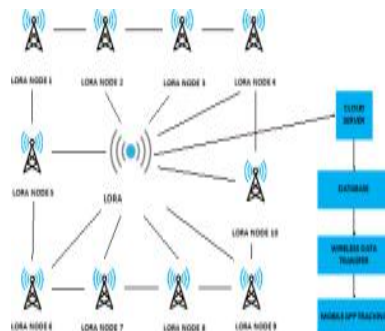


Figure 2. Receiver Module

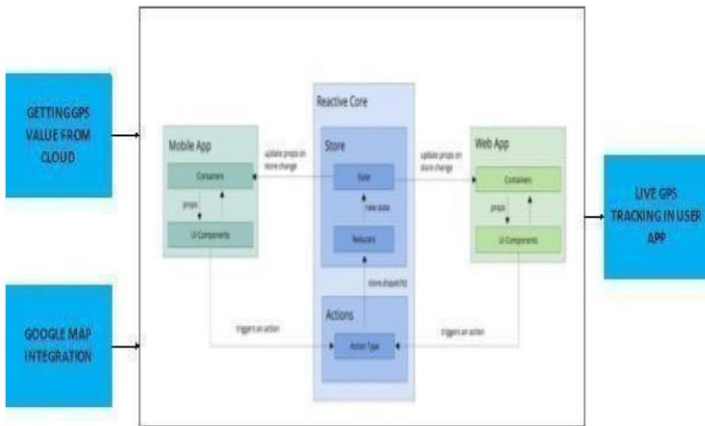


Figure 3. Internal mobile development architecture

### 2.3 Working

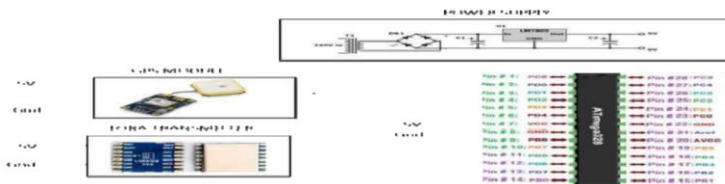


Figure 4. Transmitter circuit 1

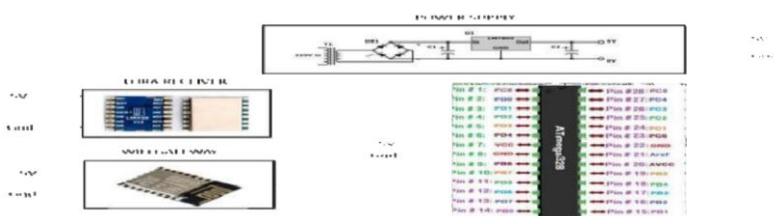


Figure 5. Receiver circuit 1

To start with the first step is to initiate the slave and master unit and then it initiates the LoRa RF module. LoRa technology offers long range, low power and secure data transmission for M2M and IoT applications. LoRa WAN defines the communication protocol and system architecture for the network by utilizing the unlicensed spectrum in the ISM bands and the long range communication which links remote sensors and gateways which are created by the LoRa physical layer. This protocol assists in the rapid setup of public or private IoT networks anywhere using hardware and software. Then it initiates the GPS module and then track the GPS location of the military people

and transmit the obtained data to the nearby slave modules. The Fig. 4 shows the transmitter circuit consisting of GPS module, LoRa transmitter, power supply unit and ATmega microcontroller. Then it transmits data to master module and then it sends the data to the cloud and finally it receives the data and integrate into GPS tracking in mobile application. The Fig. 5 represents the receiver circuit. It consists of LoRa receiver, WiFi gateway, power supply unit and ATmega microcontroller. In this concept react native is used for mobile application development. React native is a structure which constructs an order of UI components to construct the Java script code. It contains of a group of modules for iOS and Android platforms in order to build a mobile application. React native is a practical solution for constructing good quality apps in a little time period with the exact performance and user-experience standards that native apps provide. React native apps are composed into natively written code, that allows React Native to function on both operating systems and also have similar properties on both platforms without any lag. Finally it tracks the location in the map and it intimates on connection loss

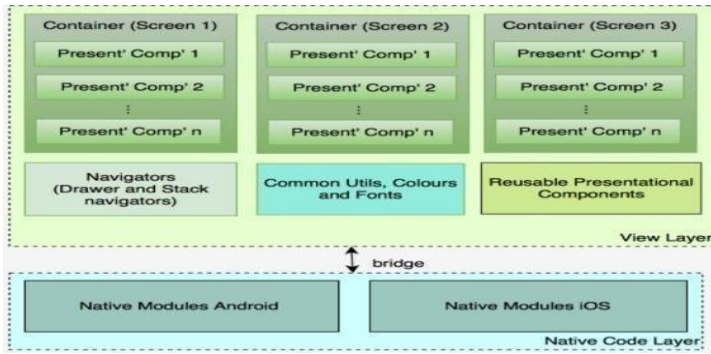


Figure 6. Mobile App development 1

### 3. Result and Discussion



Figure 7. Transmitter Hardware Setup



Figure 8. Receiver Hardware Setup



**Figure 9.** User location



**Figure 10.** LoRa tracking app

The Fig. 7 shows the transmitter hardware setup, which transmits the information to the LoRa receiver. Fig. 8 shows the receiver hardware setup. Fig. 9 shows the exact location of the user and Fig. 10 shows the LoRa tracking application which can be accessed using username and password. From Fig. 9 the exact location can be determined and in case of any emergency the soldier can be saved in an efficient way.

#### 4. Conclusion

Thus this paper suggests a strong idea for tracking the military personnel in an efficient way. The applications of this paper include asset tracking in airports and in commercial spaces. In the coming future, the application of the LoRa technology in the safety field can be reviewed and it can promote for advance in the travel industry with more accuracy. In this field there are more chances to develop or convert this idea in many ways. Thus, this concept has an efficient scope in coming future where this idea can be converted to computerized production in a cheap way.

#### Reference

- [1] Energy-efficient LoRaWAN for industry 4.0 Applications, Hafiz Husnain Raza Sherazi, Member, IEEE, Luigi Alfredo Grieco, Senior Member, IEEE, Muhammad Ali Imran, Senior Member, IEEE, and Gennero Boggio, Senior Member, IEEE, [2020, Vol No:1551-3203]
- [2] RT-LoRa: A medium Access Strategy to support Real-time flows over LoRa-based networks for industrial IoT applications, Luca Leonardi, Filippo Battaglia, Lucia Lo Bello, Senior Member, IEEE [2019, VolNo:2327-4662]
- [3] Social Information Filtering Based Electricity Retail Plan Recommender System for smart Grid End User, Fenji Luo, Member, IEEE, Gianluca Ranzi, Member, IEEE, Xibin Wang, and Zhao Yang Dong, Fellow, IEEE [IEEE 2019]
- [4] An Energy Management Strategy of Hybrid Energy Storage Systems for Electric Vehicle Applications, Chunhua Zheng, Member, IEEE, Weimen Li, Member, IEEE, and Quan Liang [2018, Vol No:2162-237X]
- [5] Long-range Low-power Wireless Networks and Sampling Strategies in Electricity Metering, MauricioC. Tom' e, IEEE Student Member, Pedro H.J. Nardelli, and Hirley Alves, IEEE Member [2018,VolNo:027]

# Efficient Face Mask Recognition System by Using Deep Learning Methodology

Hari Priya K <sup>a,1</sup> and Malathi S<sup>b</sup>

<sup>a</sup>*PG Scholar, Dept of CSE, Panimalar Engineering College, Chennai, India*

<sup>b</sup>*Professor, Dept of CSE, Panimalar Engineering College, Chennai, India*

**Abstract.** In this project, mask Recognition System is presented, that utilizes the prospect of Object Detection, completed the assistance of Deep Learning philosophies. The past work gives the topic of article identification by joining coarse-grained and fine-grained discovery philosophies without precedent for police work the moving items on high goal recordings. Period object location and acknowledgment finds careful applications in various fields like clinical applications, security police examination, and independent vehicles. There unit of estimation a few machine and profound learning procedures that unit utilized for object discovery and acknowledgment. The development of a convolutional neural organization (CNN) has given a major forward leap to protest discovery and acknowledgment. Convolutional Neural Network (CNN) has arrived at the exemplification of picture characterization for different application. Explicitly in 2D-CNN, there's huge advancement for object discovery, beside 3D-CNN, it's still toward the start of partner time. Profound CNN's unit acclimated get extra exact directions and to deal with high goal video outlines. By taking this idea of location on the grounds that the base toour work, the framework includes in perceiving the essence of the individual and checks if the face have mask or not, befittingly guaranteeing the individual complies with the assurance safety measures so as that the unfurl of hepatotoxic infection may be managed. The framework will unpredictably be utilized for future face ID with face mask till the pandemic gets died.

**Keywords:** Face Mask, Recognition, CNN, Deep Learning, face ID.

## 1 Introduction

Deep learning is Associate in Nursing AI work that mirrors the functions of the human mind in procedure information to be used in examination objects, perceiving discourse, deciphering dialects, and making options. Deep learning AI is all through a hold to travel looking out while not human bearing, drawing from information that is each unstructured and unlabelled. Deep Learning could likewise be an AI procedure upheld neural organization structures with various layers of strategy units, that has been effectively applied to an expansive arrangement of issues among the territories of picture acknowledgment and correspondence method.

<sup>1</sup>Hari Priya K, PG Scholar, Dept of CSE, Panimalar Engineering College, Chennai, India. Email:priyahari827@gmail.com<sup>1</sup>

Facial acknowledgment includes abuse figuring to distinguish human countenances in pictures or recordings, along these lines mensuration explicit facial qualities. This may typify the hole among eyes, thus the general places of the nose, jaw and mouth. This data is consolidated to make a facial mark, or profile. Pundits of veil acknowledgment conjointly expect that this new innovation might be inclined to assortment of the indistinguishable entanglements as face acknowledgment. A few of the instructing datasets utilized for biometric distinguishing proof are overwhelmed by caucasian individuals. In the AI model, Convolutional Neural Network are created abuse Python, the CNN model is that the best fitted to picture data grouping. When the picture has been preprocessed by abuse AN adequate instrument, it will be served to the fluctuated layers of the DCNN model. At stretches the CNN model, there are quantities of covered up layers that is made of neurons.

## 2 Related work

Sammy V. Militante; Nanette V. Dionisio, "Real-Time Facemask Recognition with AlarmSystem using Deep Learning", 2020 Behind the scenes of the COVID-19 pandemic, organizations, for example, the foundation experience the ill effects of basically shut all around the world if the current circumstance won't change. Corona virus otherwise called Serious Acute Respiratory Syndrome Corona infection 2 is an irresistible sickness that is delivered from a tainted debilitated individual who talks, wheezes, or hacks by respiratory drops. The dataset gathered contains 25,000 pictures utilizing 224x224 pixel goal and accomplished an exactness pace of 96% with regards to the presentation of the prepared model. The framework builds up a Raspberry Pi-based constant facemask acknowledgment that cautions and catches the facial picture if the individual distinguished isn't wearing a facemask. This investigation is gainful in battling the spread of the infection and evading contact with the infection.

Hariri Walid, "Efficient Masked Face Recognition Method during the COVID-19Pandemic", 2020 The COVID-19 is an unmatched emergency prompting countless setbacks and security issues. To diminish the spread of Covid, individuals regularly wear covers to secure themselves. This makes face acknowledgment a troublesome undertaking since specific pieces of the face are covered up. At last, the Bag-of-highlights worldview is applied on the element guides of the last convolutional layer to quantize them and to get a slight portrayal contrasting with the completely associated layer of traditional CNN. At long last, Multilayer Perceptron (MLP) is applied for the arrangement cycle. Trial results on Real-World-Masked-Face-Dataset show high acknowledgment execution.

Dan Zeng, Raymond Veldhuis and Luuk Spreeuwens," A survey of face recognition techniques under occlusion", 2020 To start with, we investigate what the impediment issue is and what inalienable troubles can emerge. As a piece of this audit, we present face identification under impediment, a primer advance in face acknowledgment. Second, we present how existing face acknowledgment strategies adapt to the impediment issue and characterize them into three classifications, which are 1) impediment powerful component extraction approaches, 2) impediment mindful face acknowledgment draws near, also, 3) impediment recuperation based face acknowledgment draws near. Moreover, they break down the inspirations, advancements, experts and cons, and the presentation of agent approaches for correlation.

Walid Hariri, "Efficient Masked Face Recognition Method During The covid-19 Pandemic", 2020 The COVID-19 is an unrivaled emergency prompting an enormous number of losses and security issues. To lessen the spread of Covid, individuals frequently wear veils to secure themselves. This makes face acknowledgment a troublesome assignment since specific pieces of the face are covered up. At long last, the Bag-of-highlights worldview is applied on the include guides of the last convolutional layer to quantize them and to get a slight portrayal contrasting with the completely associated layer of old style CNN. At last, Multilayer Perceptron (MLP) is applied for the grouping cycle. Test results on Real-World-Masked-Face-Dataset show high acknowledgment execution.

Renliang Weng, Singapore; Jiwen Lu; Yap-Peng Tan," Robust Point Set Matching for Partial Face Recognition", 2018 In the course of recent many years, various face acknowledgment techniques have been proposed in PC vision, and the majority of them utilize comprehensive face pictures for individual distinguishing proof. At that point, propose a hearty direct set coordinating with strategy toward discriminatively match these two extricated neighborhood include sets, where both the textural data and mathematical data of nearby highlights are unequivocally utilized for coordinating at the same time. At last, the likeness of two appearances is changed over as the distance between these two adjusted capabilities. Trial results on four public face informational indexes show the adequacy of the proposed approach.

### 3 Architecture

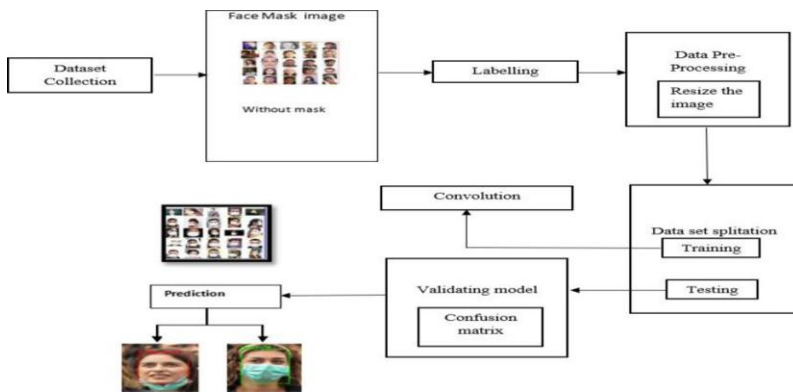


Figure 1. Face Mask recognition system architecture

Data sets are collected together. After Collecting images together, labeling the image and enter into training and test set. Collected images will test and train using deep learning with CNN. After finishing training set and test set the model will be saved. Then running the webcam which loaded the image model for live detection. Finally the face will be detect whether the face in image carry face mask or not. Predict the image whether it carry face mask or not.



### 4 Results and Discussion

Data assortment is that the initial step within the method of evaluating the outcomes and therefore the collected dataset is pre-processed to get rid of any noise or outliers if gift. Datasets area unit associate degree integral a part of machine learning. The main advantage of this field may result from advances in machine learning algorithms, constituent, and, less-intuitively, the provision of high-quality coaching datasets. The knowledge labeling, within the text of machine learning, is that the method of detective work and tagging knowledge samples. The method are often manual however is sometimes performed by the part of code as Figure 2.

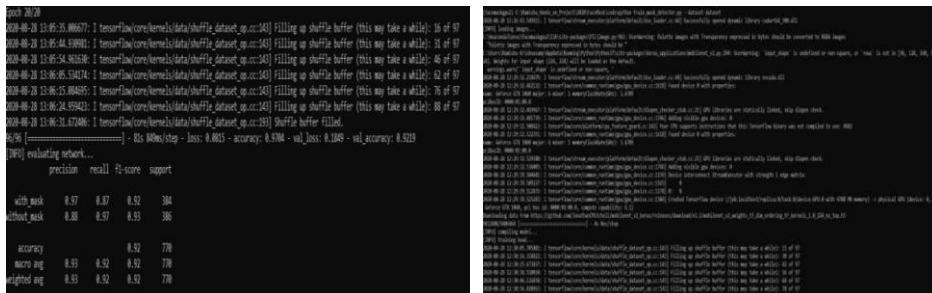


Figure 2. Execution result

### 5 Performance Metrics

The significance execution grid is a way to deal with focusing on which parts of execution ought to be dependent upon progress. In this system we get 92% of accuracy by test the dataset. Let us see the performance of proposed system in table 1:

Table 1. Performance analysis

No of input image(training)	No of input image (test)	Epoch	Training set accuracy	Test set accuracy
50	10	20	75	45
100	20	20	85	45
500	50	20	86	60
1000	200	20	89	76
1500	300	20	90	89
1900	400	20	92	92

### 6 Conclusion

Datasets area unit associate degree integral a part of the sphere of machine learning. Major advances during this field may result from advances in learning algorithms (such as deep learning), constituent, and less-intuitively, the provision of high-quality training datasets. In this section, Training and therefore the Testing datasets area unit loaded that consecutive step during this method. The photographs and captions needed

for the model area unit subjected to pre- processing and therefore the developed models area unit incorporate along to produce the expected framework. Finally the model is saved, and therefore the prediction begins.

## 7. Future goal

The objective of face recognition is, from the incoming image, to find a series of data of the same face in a set of training images in a database. The great difficulty is ensuring that this process is carried out in real-time, something that is not available to all biometric facial recognition software providers. Future works incorporate the combination of physical separating, wherein the camera distinguishes the individual wearing a facemask or not and simultaneously gauges the distance between every individual and makes an alert if the physical removing doesn't notice as expected.

## References

- [1] Sammy V. Militante; Nanette V. Dionisio, Real-Time Facemask Recognition with Alarm System using DeepLearning, 2020.
- [2] Hariri Walid, Efficient Masked Face Recognition Method during the COVID-19 Pandemic, 2020.
- [3] Dan Zeng, Raymond Veldhuis and Luuk Spreeuwers, A survey of face recognition techniques underocclusion, 2020.
- [4] Walid Hariri, Efficient Masked Face Recognition Method During TheCovid-19 Pandemic, 2020.
- [5] Renliang Weng, Singapore; Jiwen Lu; Yap-Peng Tan, Robust Point Set Matching for Partial FaceRecognition, 2018.
- [6] Deqiang He, Zikai Yao, Zhou Jiang, Yanjun Chen, JiDeng and Weibin xiang, Detection of Foreign Matter on High-Speed Train Underbody Based on Deep Learning.
- [7] Dong-ju Jeong, Insung Hwang, and Nam Ik Cho, Senior Member, IEEE., Co-salient Object Detection Based on Deep Saliency Networks and Seed Propagation over an Integrated Graph.
- [8] Dong Kyun Shin, Minhaz Uddin Ahmed and PhillKyu Rhee, Incremental Deep Learning for Robust Object Detection in Unknown Cluttered Environments.
- [9] Faisal Mehmood, Israr Ullah, Shabir Ahmad, DoHyeun Kim., Object detection mechanism based on deep learning algorithm using embedded IoT devices for smart home appliances control in CoT Journal of Ambient Intelligence and Humanized Computing.
- [10] Florin C. Ghesu, Bogdan Georgescu, Member, IEEE, Yefeng Zheng, Senior Member, IEEE, SasaGrbic, Andreas Maier, Joachim Hornegger, and Dorin Comaniciu, Fellow, IEEE, Multi-Scale Deep Reinforcement Learning for Real-Time 3D-Landmark Detection in CT Scans.
- [11] Ambeth Kumar.V.D, Dr.M.Ramakrishnan, V.D.Ashok Kumar and Dr.S.Malathi (2015).Performance Improvement using an Automation System for Recognition of Multiple Parametric Features based on Human Footprint. kuwait journal of science , Vol 42, No 1 (2015), pp:109-132.
- [12] Ambeth Kumar.V.D, V.D.Ashok Kumar, S.Malathi, K.Vengatesan, M.Ramakrishnan.Facial Recognition System For Suspect Identification Using A Surveillance Camera.Pattern Recognition and Image Analysis (Springer), Volume 28, Issue 3, pp 410-420, 2018. (DOI: 10.1134/S1054661818030136)
- [13] Ambeth Kumar.V.D and M.Ramakrishnan. Employment Of Footprint Recognition System. in the month of December for Indian Journal of Computer Science and Engineering (IJCSE) Vol. 3 No.6 Dec 2013
- [14] Ramya,T.,Dr.Malathi,S.,ratheeksha,G.R. and Dr.V.D.Ambeth Kumar (2014).Personalized authentication procedure for restricted web service access in mobile phones.Applications of Digital Information and Web Technologies (ICADIWT), 2014, Page(s):69 - 74, Bangalore, India (ISBN:978-1-4799-2258-1)
- [15] V.D.Ambeth Kumar (2018). Novel Wireless Sensing System For The Welfare Of Sewer Laborers. Healthcare Technology Letters (IET) Volume 5, Issue 4, p. 107 –112.
- [16] V.D.Ambeth Kumar et.al, .IOT Based Smart Museum Using Wearable Device. Lecture Notes in Networks and Systems, Vol.55, pp: 33-42, 2018

# Product Review Based on Machine Learning Algorithms

D.Elangovan<sup>a,1</sup>, V.Subedha<sup>b</sup>

<sup>a,1</sup>Research Scholar, Sathyabama Institute of Science And Technology, Chennai

<sup>b</sup>Professor & Head, Panimalar Institute of Technology, Chennai

**Abstract**— The purchase of products or administrations through an electronic trade called web based shopping over internet using a web browser . Online Product surveys are significant for up and coming purchasers in helping them decide. To this end, distinctive sentiment mining systems have been proposed, where making a decision about a survey sentence's direction (e.g., positive or negative) is one of their key difficulties. As of late, Machine learning has risen as powerful methods for taking care of assumption order issues. An AI model inherently learns a helpful portrayal consequently without human endeavors. In any case, we propose a regulated AI structure for item audit conclusion arrangement which utilizes pervasively accessible evaluations as powerless supervision signals. To assess the proposed system, we build a dataset containing 2, 00,000 pitifully named survey sentences and 15000 marked audit sentences from Amazon. Trial results show the more exactness contrasted with past one.

**Keywords**— Machine learning, Sentimental analysis, opinion mining, sentimental classification.

## 1. INTRODUCTION

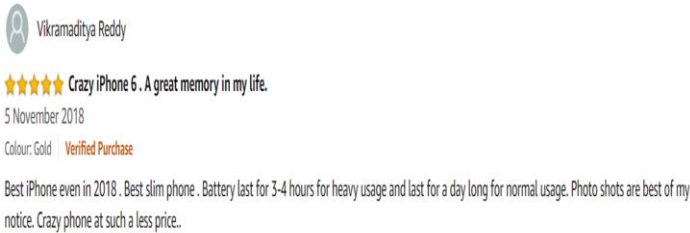
Machine learning is an exhibition paradigm utilizing model information or past experience. Machine Learning is the study of calculations that improve their presentation, at some worst experience, optimizes an exhibition standard utilizing model information or history of previous experiences. The role of Statistics is to Infer from an example and Computer science is efficient calculations to Solve the enhancement issue.

In olden days, the purchasing of items was progressively found on getting item audit from peer group like adjacent neighbors, relatives and friends as items were bought straightforwardly from dealers. Individuals trusted relatives, and companions audit about item supportive. Be that as it may, with change in innovation, we saw advancement of E-trade industry with locales overwhelmed results from various brands made accessible to clients at the dash of a single tick. The accessibility of item based destinations with doorstep conveyance has made it helpful for clients to shop on the web. It gives one stop shop to all needs of clients. With such a great amount of progress

---

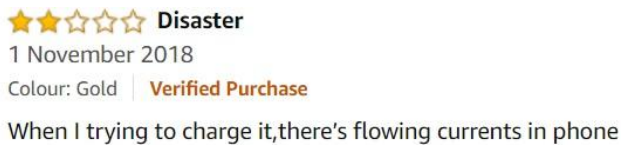
<sup>1</sup>D.Elangovan, Research Scholar, Sathyabama Institute of Science and Technology Chennai.  
Email: elangovan.durai@yahoo.com

in shopping design, we see dealers furnishing clients with input alternative about the item. Clients compose surveys from all parts of the world. There are thousands, a huge number of audits being composed. So an inquiry emerges on the most proficient method to get essential judgment about item without experiencing every one of them independently. A large number of audits are very long as well as troublesome for a potential buyer to survey and analyze them to settle on a final choice on whether the buyer should buy the item or not. More number of audits will make it cumbersome for item producers or manufacturers to keep a log of client assessments and the assumptions communicated on their items and administrations. In this way it progresses and becomes a need to create a synopsis of surveys. The rundown of audits is finished utilizing opinion examination.



**Figure 1.** Positive Reviews

In general, Slant investigation concentrates more on emotional data required for source materials by applying normal idea of regular dialect handling the principle errand lies in distinguishing whether the assessment expressed is sure or negative. Since clients normally don't express feelings in basic way, here and there it winds up repetitive errand to pass judgment on a supposition expressed.



**Figure 2.** Negative Reviews

A few suppositions are proximal ones while others are immediate. The Nostalgic examination enables client to imagine fulfillment while obtaining the basic synopsis of these surveys classified into positive or negative-two more extensive arranged classes. After realizing current market drifts about items which is very useful for creating market methodologies by traders, the Criticisms are principally utilized by the buyers to purchase the goods and services on the web.

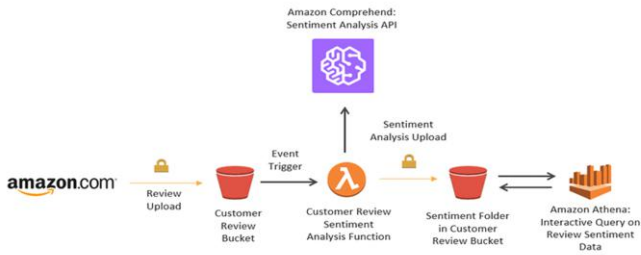


Figure 3. Overview of Amazon sentimental analysis

## 2. RELATED WORKS

Determining a consensus opinion on a product sold online is no longer simple as appraisals have become increasingly more on the Internet. To address this issue, analysts have utilized various like searching for sentiments communicated in the reports, investigating the appearance and sentence structure of audits. The Perspective based assessment is the most significant part of supposition mining and analysts are getting increasingly intrigued by item viewpoint extraction. The progressively complex calculations are expected to address this issue decisively with enormous informational indexes. This acquaints a strategy with extricate and abridge item angles and then compare sentiments from countless item audits in a particular area. This amplifies the exactness as well as convenience of the audit outlines utilizing information about item angle extraction and giving both a proper degree of detail and rich portrayal capacities.

Various researchers have worked in the field of end assessment, each one proposing better methodology for providing indications of progress adequacy from AI draws near. A LSA to separate thing incorporate inclination words which are required to get right sentences to wind a summary of reviews, with empowering just picked features to exhibit the last items, along these lines, reducing genuine size of once-over [1]. In [2] creator talks about the specific issues inside supposition assessment field which consolidates; report level, sentence level, feature level, comparative appraisal and conclusion jargon issue.

Bo hurt [4] considers masterminding reports not by subject, but instead overall inclination, wrapping up whether a study is positive or negative. The Overviews are changed over to essential decision by making use of systems. Since evaluations are not for each situation facilitate for instance "the nokia phone is extraordinary" yet moreover it might be a close to feeling like "nokia phone has best battery life over Samsung". There are three measurements namely sentence level, report level and feature level at which ends are gathered [8]. At sentence level, conceptual and target suppositions exist, whereas at document level, a record is portrayed reliant on all things considered presumption conveyed by end holder. At feature level, the characteristics of things are contemplated, which gives request through and through. In paper [5], an all encompassing vocabulary based methodology is suggested that enables the framework to deal with sentiment words that are setting subordinate. It considers the checking of

the quantity of positive and negative supposition words close to the item include in each sentence. On the off chance that the number of positive feeling words are more than that of negative supposition words, the last expectation on the component is sure else negative. Author in [6] makes utilization of higher n-gram demonstrate utilizing three classifiers. The first being dialect demonstrate which is a generative strategy that processes the likelihood of age of a word arrangement. The Passive-Aggressive calculations are second which comprises of a group of edge based web based learning calculations for parallel characterization. Third, to foresee the extremity of an audit. Aside from characterizing audits in two more extensive classes, there likewise exists a term extremity degree to quantify the quality of sentiments, as in is the conclusion firmly positive, somewhat positive, and exceptionally negative and so forth [8].

Author in [9] says result of notion esteem and happening recurrence gives estimation of suppositions. The approach figures the general notion of expressed stubborn content like client audits and scales them as a genuine score between - 1 and +1, which would then be able to be effectively changed positive/negative grouping or into a size of 1-5 stars. Making applicant list utilizing POS labelling with evacuation of stop word prompts viewpoint distinguishing proof. The viewpoint having fewer than 5 remarks on it, is expelled from the competitor list.

In paper [10], the item audit is converted into a Vector of Feature Intensities (VFI). A VFI is a vector of  $N+1$  esteem, every one speaking to an alternate item highlight and alternate highlights. Snyder and Barzilay [11] tended to the issue of investigating various related suppositions in a content and introduced a calculation that mutually gets the hang of positioning models for individual angles by demonstrating the conditions between allocated positions [20].

### 3. PROPOSED SYSTEM

#### 1. Dataset

The dataset was gathered from various item destinations identified with portable space item audits like .cnet.com, downlaod.com, reviewcentre.com, zdnet.com, epinions.com and consumereview.com, Amazon.com

#### 2. Pre-Processing

The unstructured dataset may contain dull words, large number of words that are in no way required in delineating of opinions. Pre-getting ready incorporates clearing of stop words, for instance, 'as well as', 'that, etc sought after by guard stemming which incorporates streamlining objective words into base words by ejection of increments like ed, ate, particle, ional, ment, ator, ssess, es, ance or transformation from ator to ate . For instance, "substitution" is stemmed to replace, "upset" to inconvenience, "glad" to happi and "administer" to work. The crude information is pre-handled to the show remarkable signs of quality improvement .

### 3. *Extraction*

The features in surveys are extracted with the goal that it encourages the client to realize the positive and negative remarks of various features. Since, by and large the decision about item is truly necessary yet there is additionally circumstance where client prerequisites come into the situation. The utilization of descriptors is done using unigram model to order suppositions like positive or negative. For instance, "the Samsung camera I purchased was acceptable; it has got incredible touch screen, wonderful spotlight." The component separated out of it would resemble: Domain: Flexible; Product: Samsung; Feature: Camera; Adjective: Good.

### 4. *Compare Model*

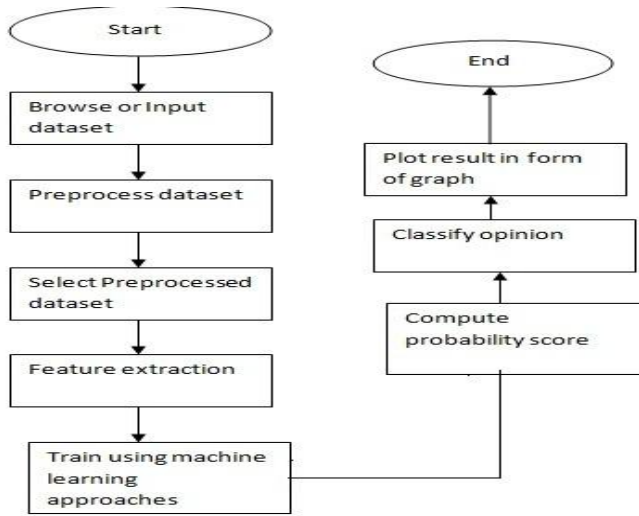
Managed learning creates a capacity which maps contributions to wanted yields likewise called as marks since they are preparing models named by human specialists. The Naive-Bayes and Support Vector Machine methods are applied to complete regulated learning on the available datasets .

### **The pseudo code**

Input- Dataset of Amazon product reviews

Output- positive and negative Classification

- 1: Preprocess the data
  - Removal of special characters
  - Removal of stop words
  - Stemming the word
- 2: feature list
  - If word in stop word list
  - Removal word
  - Return file
  - Else append word to file
- 3: Extract feature list
  - Match every word in pre processed list
  - If word matches adjective in base list
  - Display word
  - If word matches feature in base list
  - Display feature
- 4: combine both feature and preprocessed list
- 5: Use machine learning algorithms
  - Compute probability
- 6: classify opinion as positive, negative or neutral.



#### 4. CONCLUSION

The Sentiment analysis is used to identify and aggregate the sentiment or opinions expressed by the users. It is used to classify the polarity of text in document or sentence in terms of the opinion expressed as positive, negative or neutral. Our proposed system is found to give better accuracy compared to previous approaches. It takes much more computation time for text files that are too large in size. The automatic sentimental analysis is very useful to identify and predict current and future trends.

The future scope of improvement is to

- Review the product based on opinion in different languages.
- Trade with problem of mapping slangs.
- Add sarcastic opinion.
- Recognizing similar feelings and discovering which among two item looked at is best one.

#### REFERENCES

- [1] Liu, Chien-Liang, et al., Movie rating and review summarization in mobile environment. Systems, Man, and Cybernetics, Part C: IEEE Transactions on Applications and Reviews, Volume 42 issue 3, pp.397-407,2012.
- [2] Feldman, Ronen. Techniques and applications for sentiment analysis. Communications of the ACM 5, Volume 56 Issue4, pp.82-89,2013.



- [3] Hearst, Marti A., Susan T. Dumais, Edgar Osman, John Platt, and Bernhard Scholkopf. Support vector machines. *Intelligent Systems and their Applications*, IEEE 13, Volume. 4 .pp.18-28, 1998.
- [4] Pang, Bo, , et al., Thumbs up?: sentiment classification using machine learning techniques. In *Proceedings of the ACL-02 conference on Empirical methods in natural*
- [5] Ding, Xiaowen, et al., A holistic lexicon-based approach to opinion mining. *Proceedings of the 2008 International Conference on Web Search and Data Mining*. ACM, pp. 231-240, 2008.
- [6] Cui, Hang, , et al., Comparative experiments on sentiment classification for online product reviews. *Proceedings of the 21st national conference on Artificial intelligence (AAAI)*. Volume 2, pp 1265-1270, 2006.
- [7] Jebaseeli, A, et al.,. A Survey on Sentiment Analysis of (Product) Reviews. *International Journal of Computer Applications* 47, Volume 11, pp36-39, 2012.
- [8] Wang, Min, , et al., Research on sentiment analysis technology and polarity computation of sentiment words. *Progress in Informatics and Computing (PIC)*, 2010 IEEE International Conference on. Vol. 1. IEEE, 2010
- [9] Mudinas, Andrius, , et al., Combining lexicon and learning based approaches for concept-level sentiment analysis. *Proceedings of the First International Workshop on Issues of Sentiment Discovery and Opinion Mining*. ACM, pp330-333, 2012.
- [10] de Albornoz, , et al. A joint model of feature mining and sentiment analysis for product review rating. *Advances in information retrieval*. Springer Berlin Heidelberg, pp.55-66, 2011.
- [11] Mattosinho, F. , et al., Thesis on Mining Product Opinions and Reviews on the Web. Technische Universitat Dresden ,2010.
- [12] Pang, Bo, et al., Thesis on Opinion mining and sentiment analysis. *Foundations and trends in information retrieval* Volume1-2,pp 1-135,2008
- [13] Zhu, Jingbo, et al. Aspect-based opinion polling from customer reviews. *IEEE Transactions on Affective Computing*, Volume 2.1,pp.37-49, 2011.
- [14] Na, Jin-Cheon, , et al., Effectiveness of simple linguistic processing in automatic sentiment classification of product reviews. *Advances in Knowledge Organization* Volume9, pp. 49-54, 2004.
- [15] Nasukawa, Tetsuya, , et al., Sentiment analysis: Capturing favorability using natural language processing. In *Proceedings of the 2nd international conference on Knowledge capture*, ACM, pp. 70-77, 2003.
- [16] Li, Shoushan, Zhongqing Wang, , et al., Sentiment Classification with Polarity Shifting Detection. In *Asian Language Processing (IALP)*, 2013 International Conference on, pp. 129-132. IEEE, 2013.
- [17] M.Karamibekr,A. , et al., Oriented Sentiment Classification, *Processed of the IEEE/WIC/ACM International Conferences on Web Intelligence and Intelligent Agent Technology (WI-IAT)*, Vol (1): pp. 327-331, 2012.
- [18] Melville, Prem, , et al., Sentiment analysis of blogs by combining lexical knowledge with text classification. In *Proceedings of the 15th ACM SIGKDD international conference on Knowledge discovery and data mining*, pp. 1275-1284. ACM, 2009.
- [19] Abbasi, Ahmed, sentiment analysis in multiple languages: Feature selection for opinion classification in Web forums. *mACM Transactions on Information Systems (TOIS)* Volume 26 issue 3, pp.1- 12, 2008.
- [20] Ambeth Kumar.V.D (2017).Efficient Routing for Low Rate Wireless Network a Novel Approach. *International Journal of Image Mining*, Vol. 2, Nos. 3/4, 2017, 2017

# Delineation of Lung Tumor with Neural Networks

Kalpana R. A<sup>a</sup>, Ganga A<sup>b</sup>, Deepika R<sup>b</sup>, Kiruthiga Devi M<sup>b</sup>, Ramya N<sup>b</sup>  
*<sup>a,b</sup> Assistant Professor, Dept of CSE, Sairam Engineering College Chennai, India*

**Abstract.** Due to the picture similar region of interest, local area, and the effect of respiration, separating a lung tumor from neighboring tissue from a collection of magnetic resonance images (MRI) faces a number of challenges. However, precise tumor segmentation is needed when preparing radiation therapy in order to prevent excessive radiation exposure to healthy tissues. Delineation of the whole MRI pattern by hand is boring, time-consuming, and costly. Using neural networks, this research studies the automated tracking of tumor borders during radiation therapy. To improve the accuracy of lung tests, we proposed using neural network architecture with fuzzy clustering.

**Keywords:** Lung Tumor Detection, Neural Network, Lung Regions, Fuzzy Clustering.

## 1. Introduction

Lung cancer is a condition that causes cells to divide in the lungs uncontrollably. This causes the growth of tumors that reduce a person's ability to breathe. Identifying lung cancer in its earliest stages can be difficult, however, because the symptoms may be similar to those of a respiratory infection, or there may be no symptoms at all. Recently, image processing techniques are widely used in several medical areas for image improvement in earlier detection and treatment stages. Lung cancer is a disease of abnormal cells multiplying and growing into a tumor. Image segmentation is a fundamental step in computerized image analysis. It deals with separating classes in an image into continuous and separate regions. Delineation of lung tumor from adjacent tissue from a series of magnetic resonance images (MRI) poses various problems due to the image identical region of interest, surrounding area and the influence of respiration. This study investigates automatic tracking of tumor boundaries during radiation therapy using neural networks. We proposed to use a neural network architecture with fuzzy clustering to improve the accuracy in lung studies.

---

<sup>1</sup>Kalpana R A, Assistant Professor, Dept of CSE, Sairam Engineering College, Chennai, India.  
Email:kalpana.cse@sairam.edu.in<sup>1</sup>

## 2. Related Works

In this modern world, all the people were busy with their tight schedule. Due to which most of the people were not health conscious and suffer from various diseases. One of the commonly occurring defects among human is lung failure which occurs due to various reasons.[1] Over the last decade, a plethora of computer-aided diagnosis (CAD) systems have been proposed aiming to improve the accuracy of the physicians in the diagnosis of interstitial lung diseases (ILD). The feature extraction method relies on local spectral analysis using a DCT-based filter bank. After convolving the image with the filter bank, q-quantiles are computed for describing the distribution of local frequencies that characterize image texture. Then, the gray-level histogram values of the original image are added forming the final feature vector. The classification of the already described patches is done by a random forest (RF) classifier.[2] Current computed tomography (CT) technology allows for near isotropic, sub millimeter resolution acquisition of the complete chest in a single breath hold. These thin-slice chest scans have become indispensable in thoracic radiology, but have also substantially increased the data load for radiologists. Automating the analysis of such data is, therefore, a necessity and this has created a rapidly developing research area in medical imaging.[3] Diagnosis of lung nodules and cancers is a critical and urgent problem in clinical diagnosis. This thesis is to design and build a computer aided lung ground glass opacity (GGO) nodules and large lung cancers diagnosis system which aims to quantify the volumetric change of the lung GGO nodules and large lung cancers between the pretreatment and post-treatment. Sputum cytology examination has been shown in several studies to lead to detection of lung cancer at an earlier stage, resulting in an improved 5-year survival rate.

## 3. Existing System

In the existing system, lung features are extracted by manual analysis and it is very time consuming process. The thresholding method is not accurate in comparing the normal and abnormal lung.

- Not applicable for multiple images for Tumor detection in a short time
- Difficult to get accurate results
- Medical Resonance images contain a noise caused by operator performance which can lead to serious inaccuracies classification

## 4. Proposed System

In proposed methodology, the MRI (Magnetic Resonance Image) image is pre-processed using DWT (Discrete Wavelet Transform). Key features are extracted using Gray level co-occurrence matrix (GLCM). A data set of test data containing normal and abnormal lung MRI images are classified using Neural Network. Feature extraction using GLCM Features. In the similar way, identifies contours by identifying differences between regions (edges).

The input test image is pre-processed using Discrete Wavelet Transform. Image enhancement or pre-processing is done to remove noise and brighten the image to identify the key features. The Gray level co-occurrence matrix determines the texture

features of an image by calculating how often the pixel pairs with specific values. First, it creates a GLCM and then extracts the significant texture features from this matrix. Training dataset consists of a set of images consisting of normal and abnormal lung. The training process is same as the processing of test image, which involves pre-processing, and feature extraction. The features extracted from the trained set are used for comparison with the features extracted from the test image for accurate classification of lung tumor, which is done using method of neural network. Fuzzy clustering is an unsupervised clustering technique which does not demand a human interaction to decide the clustering criteria. It performs on distance metrics between the data point and cluster centre by assigning a membership function to each data point corresponding to each cluster centre. Comparing to k-means clustering fuzzy-c means works well for overlapped data set thus enabling us to find the accurate location of the lung tumour.

## 5. Working System

A software application in general is implemented after navigating the complete life cycle method of a project. System implementation is an important stage of theoretical design is turned into practical system. Implementation is the stage of the project when the theoretical design is turned out into a working system. Thus it can be considered to be the most critical stage in achieving a successful new system and in giving the user, confidence that the new system will work and be effective. The implementation stage involves careful planning, investigation of the existing system and its constraints on implementation, designing of methods to achieve changeover and evaluation of changeover methods. Each program is tested individually at the time of development using the data and has verified that this program linked together in the way specified in the programs specification, the computer system and its environment is tested to the satisfaction of the user. The system that has been developed is accepted and proved to be satisfactory for the user and so the system is going to be implemented very soon. A simple operating procedure is included so that the user can understand the different functions clearly and quickly. The final stage is to document the entire system which provides components and the operating procedures of the system.

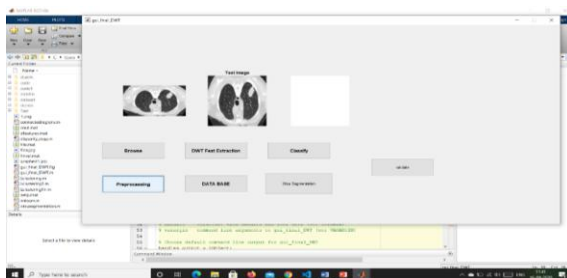
## 6. System Architecture And Implementation

A modular design reduces complexity, facilities change (a critical aspect of software maintainability), and results in easier implementation. The five important criteria that enable us to evaluate a design method with respect to its ability to define an effective modular design are: Modular decomposability, Modular Comps ability, Modular Understandability, Modular continuity, Modular Protection.

### *Module 1: Preprocessing and Feature extraction*

In this module resizing and removing the unwanted data from the blood microscopic image dataset and down sampling the images so that we can train faster. Preprocessing operations are applied on input data image for smoothening the cancer part. Dilation and erosion process will be used to enhance (smoothening) the cancer region by

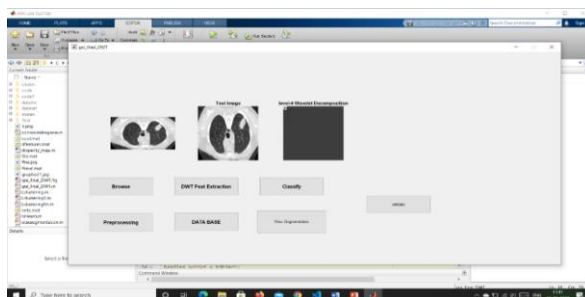
removing the unwanted pixels from outside region of cancer part. These morphological operations are performed on images based on shapes. The output pixel is determined by using these processing pixel neighbors. Feature extraction is a process of dimensionality reduction by which an initial set of raw data is reduced to more manageable groups for processing. A characteristic of these large image data sets is a large number of variables that require a lot of computing resources to process.



**Figure 1.** Preprocessing and Feature extraction

### *Module 2: GLCM with Segmentation*

Given Input image composed of pixels each with an intensity (a specific gray level), the GLCM is a tabulation of how often different combinations of gray levels co-occur in an image or image section. K -means clustering algorithm is an unsupervised algorithm and it is used to segment the interest area from the background. But before applying K -means algorithm, first partial stretching enhancement is applied to the image to improve the quality of the image. Subtractive clustering method is data clustering method where it generates the centroid based on the potential value of the data points. So subtractive cluster is used to generate the initial centers and these centers are used in k-means algorithm for the segmentation of image.



**Figure 2.** GLCM with Segmentation

### Module 3: NN Training and Classification

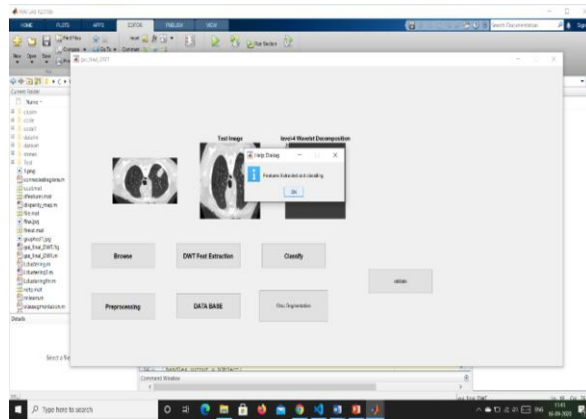


Figure 3. NN Training and Classification

## 7. Future Scope

In future work, the proposed methodology will be designed for real time implementation by interfacing it with the scanning machines. The captured lung image will be subjected to the proposed algorithm to identify the affected region and for accurate classification of lung tumor.

## 8. Conclusion

The project presented that automated CT lung cancer classification for early stage abnormality detection of Pneumonia and TB with use of neural network classifier and spotting of cancer was done with image segmentation. Pattern recognition was performed using Back propagation with feed forward neural network and pattern will be characterized with the help of principal component analysis. Spatial fuzzy clustering algorithm was utilized effectively for accurate cancer detection to measure the area of abnormal region. From an experiment, system proved that it provides better classification accuracy with various stages of test samples and it consumed less time for process.

## References

- [1] Dignam JJ, Huang L, Ries L, Reichman M, Mariotto A, Feuer E, Estimating cancer statistic and other-cause mortality in clinical trial and population-based cancer registry cohorts, *Cancer* 10, Aug 2009.
- [2] T. C. Kennedy, Y. Miller and S. Prindiville, Screening for Lung Cancer Revisited and the Role of Sputum Cytology and Fluorescence Bronchoscopy in a High-Risk Group, *Chest Journal*, vol. 10, pp. 72-79, 2005.
- [3] Z. Daniele, H. Andrew, J. Nickerson, Nuclear Structure in Cancer Cells, *Nature Reviews Cancer*, Medical School, vol. 4, no. 9, pp. 677-87, USA, Sep. 2004.
- [4] Georgiadis. Et all, Improving Lung Cancer characterization on CT by probabilistic neural networks and non-linear transformation of textural features, *Computer Methods and program in biomedicine*, vol 89, pp24-32, 2008.

# Detection and Identification of Pancreatic Cancer Using Probabilistic Neural Network

Ramya N<sup>a,1</sup>, Manoj Kumar B<sup>b</sup>, Vijay Balaji B<sup>b</sup>, Kiruthiga Devi M<sup>b</sup> and Deepika R<sup>c</sup>

<sup>a,1,c</sup> Assistant Professor, Dept of CSE, Sri Sairam Engineering College, India

<sup>b</sup> UG Scholar, Dept of CSE, Sri Sairam Engineering College, Chennai, India

**Abstract.** The fact that pancreatic cancer has a low life expectancy, that is only 9% of people survive five years, makes a diagnosis catastrophic. The majority of patients are diagnosed late in life, where care choices are minimal. Early diagnosis of pancreatic cancer will greatly increase a person's chances of survival. Accurate PC staging will help doctors have the right treatment plan for PC patients at different stages, as well as the diagnostic measures needed for a quicker cancer recovery. In this proposed project, ultrasound images will be analyzed. The noise in the image is minimised using the Median Filter. In the next step, Gray Level Co-occurrence Matrix (GLCM) and Discrete Wavelet Transform (DWT) are used to extract related features. Following this extraction step, the refined characteristics are fed into a Probabilistic Neural Network (PNN) neural network classifier, which determines whether or not cancer is present. Metrics such as sensitivity, precision, and specificity are used in experimental computation.

**Keywords.** Pancreatic cancer, Ultrasound image, DWT, GLCM, PNN, Deep Learning.

## 1. Introduction

THE Pancreatic cancer is the tenth most common cancer in men and the ninth most common cancer in women in the US, however, it is the fourth most common cancer in both men and women. By 2020, pancreatic cancer is expected to lead lung cancer as the second leading cause of death in the US, demonstrating the disease's seriousness. However, India's annual pancreatic cancer burden was about 17,000 patients in 2008, and this number is projected to grow in the coming years. Multi centric research, a more comprehensive approach to reporting at all stages, and the identification of there have been potentially preventable risk factors for pancreatic cancer in the country India are all important in this situation. One of the main reasons for this is that there are no reliable early detection approaches for pancreatic tumors. Furthermore, the majority of the symptoms of a pancreatic tumor are unclear and may be caused by a number of other abdominal problems. Pain, weight reduction, conjunctivitis, loss of appetite, nausea, digestive changes, and diabetes are all some of the symptoms. After months of experiencing these symptoms, most patients seek professional advice.

---

<sup>1</sup>Ramya N, Assistant Professor, Dept of CSE, Sri Sairam Engineering College, Chennai, India. E-mail: ramya.cse@sairam.edu.in

As a result, most patients are diagnosed with a pancreatic tumors after it has progressed to the point that surgery is no longer an option. This is due to the fact that most large blood vessels are unable to be resected. Treatment becomes much more complex if the cancer has spread to other organs. As a result, there is an immediate need for a tool that will aid radiologists in the early detection of pancreatic tumors. The ultrasound images are used to process in this article. To remove the noise in the image, we use the Median Filter. DWT and GLCM are used to extract relevant features in the next step. The refined features are then fed into Probabilistic Neural Network (PNN) classifier which detects the cancer is present or not.

## 2. Related Works

[1] This paper was the first to implement an EL-SVM-based classification method involving pancreatic CT images. In terms of classification, the EL-SVM system performed best. The study will help to resolve some of the issues encountered in preoperative PC diagnosis and provide treatment options for different phases of PC patients which are achievable. It could not detect the early stage of the cancer.[2] In this paper, Because of the lethal nature of PDAC, it's important to rule out pancreatic cysts, which can be found in up to 16% of healthy people and can turn into PDAC. Pancreatic cysts come in a wide variety of sizes and forms, making accurate segmentation difficult, which limits for clinical manifestations, computer-aided analysis of CT images is being used. Using densely linked CNN, the author proposed, without pre-segmenting the condition, a framework for earlier staging and diagnosis of pancreatic tumour has been developed. The Dense-Net determine the significant features from the entire pathological pancreas and produces mappings between the appearance of pancreatic cysts on diagnostic devices and various pathological types of pancreatic cysts. They added feature vectors to the framework that helps physicians understand the deep learning method's decision, which improved facilitates business. On a population of 206 individuals with four psychotically identified subtypes of pancreatic tumour, the test had a prediction performance of 72.8%, which is considerably high than the standard accuracy of 48.1%. The high efficiency of the evolved approach on this complicated dataset obviously supports its therapeutic implications. [3] In this paper, HMI is an elasticity imaging technique used to measure tissue stiffness by measuring tissue dynamic displacements triggered by intermittent ultra - sonic radiation power. The aim of this study was to see if HMI could be used to detect pancreatic tumours and track HIFU high-intensity centred ultrasound care. The HMI system included a centred ultrasound transducer (FUS), which used diagnostic ultrasound transducer that used periodic radiation force to induce dynamic tissue movement at 50 Hz and 1D cross-correlation of acquired radiofrequency signals of ultrasound echoes to detect axial tissue displacement within the targeted region. HMI displacement images of cancer cells in a mouse model and healthy pancreases in a bizarre mouse model were constructed for pancreatic cancer classification. FUS was used to simultaneously induce HIFU thermal endoscopy and tissue motion for pancreatic tumour brachy therapy monitoring, allowing HMI monitoring without disrupting tumour endoscopy. Both pancreases were excised immediately after dilution for histological examination. Normal and malignant tissue were completely separated using HMI displacement images. The HMI monitoring shows significant pancreatic stiffening after 2 minutes of HIFU ablation, and histological analysis confirmed the development of thermal tumours. HMI was the first to prove that this could be used to



detect pancreatic tumours and influence HIFU ablation in this research. It was also the first time an imaging technique centered on radiation force was used to control abdominal cancer HIFU diagnosis [7-11].

### 3. Existing System

- The existing system methodology is detecting the cancer using the CT (Computed Tomography) images.
- The LASSO algorithm (Least Absolute Shrinkage and Selection Operator) was chosen for feature selection of the images in it.
- It uses Ensemble Learning-Support Vector Machine (EL-SVM) as classifier to classify the tumour in pancreas.
- Accuracy of the system was about 85%.
- It cannot give accurate results for the early stage of cancer.

### 4. Proposed System

- Ultrasound images are used for detecting the pancreatic cancer is present or not.
- Features are extractions of images are done using Gray Level Co-occurrence Matrix (GLCM) and Discrete Wavelet Transform (DWT).
- Probabilistic Neural Network (PNN) detects the cancer from the extracted features of input image and dataset images.
- It also identifies the stage of cancer whether it is benign or malign.

### 5. Overview of The Project

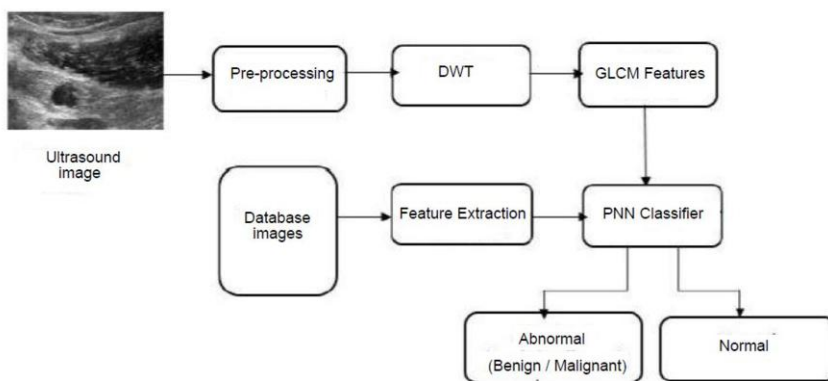


Figure 1. Architecture diagram of the project

At the first step, the given input image is preprocessed and then the feature of image are extracted using GLCM and DWT. Then the dataset is loaded and its features are extracted. The feature vector of the input and the dataset are given to the PNN classifier which detects and identifies the stage of cancer.

## 6. Implementation

### 6.1 Module 1: Preprocessing



Figure 2.

Pre-processing is a technique for improving image data by eliminating unnecessary anomalies or optimizing image features that are needed for image acquisition. It accepts and generates intensity images. The method of estimating the clean original image from a corrupted/noisy image is called as image restoration.

### 6.2 Module 2: Feature Extraction

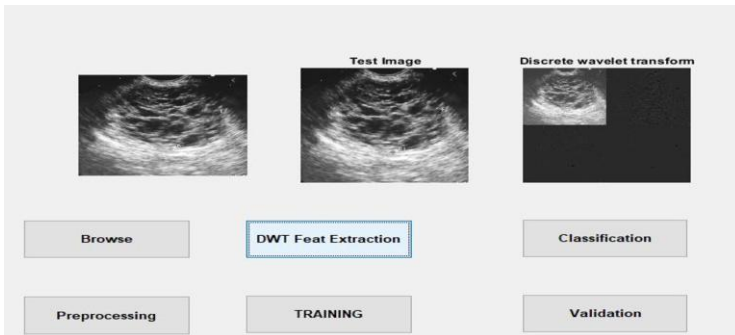


Figure 3.

Feature extraction is the method of extracting quantitative information from an image, such as colour features, texture, shape, and contrast. Wavelet coefficients were extracted using the discrete wavelet transform (DWT), and statistical features were extracted using the gray-level co-occurrence matrix (GLCM).

### 6.3 Module 3 : Classification

The PNN classifier classifies the input image by comparing with the dataset images and identifies whether cancer is present or not and also the stage of cancer.

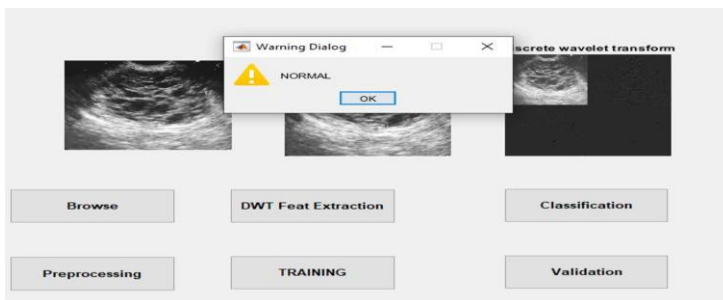


Figure 4.

## 7. Conclusion

It detects whether the cancer is present or not and if it is present then it identifies the stage of the cancer whether benign or malignant. The accuracy of this project is above 90%. However, in future more samples can be given to the dataset and the accuracy can be increased.

## References

- [1] Min Li, Xiaohan Nie, Yilidan Reheman, Pan Huang, Shuailei Zhang, Yushuai Yuan, Chen Chen, Ziwei Yan. Computer-Aided Diagnosis and Staging of Pancreatic Cancer Based on CT images. IEEE, vol.8, July 2020.
- [2] Bengio.Y, P. Simard, and P. Frasconi. Learning long-term dependencies with gradient descent is difficult. IEEE transactions on neural networks, 5(2):157–166, 1994.
- [3] M.I.Canto, F. Harinck, R. H. Hruban, G. J. Offerhaus, J. W. Poley, I. Kamel, Y. Nio, R. S. Schulick, C. Bassi, I. Kluijft, M. J. Levy, A. Chak, P. Fockens, M. Goggins, and M. Bruno. International cancer of the pancreas screening (caps) consortium summit on themanagement of patients with increased risk for familial pancreatic cancer. Gut, 62(3):339–47, 2013.
- [4] Daffa Fajri Riesaputri; Christy Atika Sari; Ignatius Moses Setiadi De Rosal; Eko Hari Rachmawanto. .Classification of Breast Cancer using PNN Classifier based on GLCM Feature Extraction and GMM Segmentation. IEEE, October 2020.
- [5] Sachdeva J, Kumar V, Gupta I, Khandelwal N, Ahuja CK (2013) Segmentation, feature extraction, and multi class brain tumor classification. J Digit Imaging 26(6):1141–1150
- [6] Demirhan A, Toru M, Guler I (2015) Segmentation of tumor and edema along with healthy tissues of brain using wavelets and neural networks. IEEE J Biomed Health Inform 19(4):1451–1458
- [7] Hema Kumar.S, J.Uday Kiran, V.D.AKumar, G.Saranya, Ramalakshmi V .Effective Online Medical Appointment System. International Journal of Scientific & Technology Research , Volume 8, Issue 09, September 2019, Pages 803 – 805.
- [8] Ambeth Kumar.V.D and M.Ramakrishnan, V.D.Ashok Kumar and Dr.S.Malathi (2015) .Performance Improvement using an Automation System for Recognition of Multiple Parametric Features based on Human Footprint .kuwait journal of science , Vol 42, No 1 (2015), pp:109-132.
- [9] V.D.Ambeth Kumar, V.D.Ashok Kumar, S.Malathi, K.Vengatesan, M.Ramakrishnan .Facial Recognition System For Suspect Identification Using A Surveillance Camera . Pattern Recognition and Image Analysis (Springer), Volume 28, Issue 3, pp 410–420, 2018. (DOI: 10.1134/S1054661818030136)
- [10] Ambeth Kumar.V.D and M.Ramakrishnan .Employment Of Footprint Recognition System . in the month of December for Indian Journal of Computer Science and Engineering (IJCSE) Vol. 3 No.6 Dec 2013
- [11] Ramya,T.,Dr.Malathi,S.,ratheeksha,G.R. and Dr.V.D.Ambeth Kumar (2014).Personalized authentication procedure for restricted web service access in mobile phones.Applications of Digital Information and Web Technologies (ICADIWT), 2014, Page(s):69 - 74, Bangalore, India (ISBN:978-1-4799-2258-1)

# Automatic Bridge Monitoring System Using IoT

SharmikhaSree.R<sup>a,1</sup>, Meera.S<sup>b</sup>, Deepika.R<sup>b</sup>, DivyaS<sup>c</sup>, Priyadarshini V S<sup>c</sup>

<sup>a,b</sup>Assistant Professor, Dept of CSE, Sri SaiRam Engineering College, Chennai, India

<sup>c</sup>UG Scholar, Dept of CSE, Sri Sai Ram Engineering College, Chennai, India

**Abstract**— Monitoring the bridge is very important as a poor bridge may lead to many accidents. Therefore it needs a system to monitor the strength or stability of the bridge in order to avoid any failures. Cracks may occur due to accidents or overload in the bridges which will be identified by the mems sensor. The bridge monitoring system is significant for monitoring bridges or flyovers. The aim is to develop an IOT based bridge monitoring system that will automatically detect the cracks and checks if there is an increase in vibration. Different sensors are used for monitoring. It also monitors the light in the bridge which is very important especially during nighttime. It also checks if the heat of cables in bridges increases which may cause fire and also checks the fire.

**Keywords:** MEMS sensor, Vibration sensor, Fire sensor, GSM.

## 1. Introduction

Is bridge really important? what happens if there is the absence of a bridge in a heavy traffic area? Yes, there is a need for the bridge without which there will be severe consequences. Bridge is very important as poor bridge leads to many accidents. Therefore it needs a system to monitor the health of bridge which is being one of the diagnostic tools that prevents the causes from progression and avoid any failure. It identifies the crack that occurs due to accidents or overload in the bridge. It is significant for monitoring bridges and flyovers and it automatically detects the cracks and if checks and if any increase in vibration. It also monitors the light in the bridge especially during nighttime and also checks if the heat of cable in the bridges increases if may cause fire and also checks the fire.

## 2. Related work

There are various works in this field of study. The first reference is from[1] where the author uses a wireless sensor network for bridge monitoring. For fire detection, there are lot of methods especially from[2] where fire detection is done using a fire sensor.

<sup>1</sup>Sharmikra Sree R, Assistant Professor, Dept of CSE, Sri Sai Ram Engineering College, Chennai, India. Email:sharmikasree.cse@sairam.edu.in<sup>1</sup>

The paper[3] is for vibration detection Where vibration in the bridge is monitored. In paper [4] the author uses a mems sensor for crack monitoring. It works by angle detection. In[5] the author monitors the strain of the bridge which may cause due to overload [6-8].

### 3. Proposed System Methodology

In this project, we use a mems sensor to detect cracks. Mems sensor works by measuring the angle, so even if a small crack occurs there will be a change in angle. Even if there is a slight change in the angle it will indicate us the next second which will be quicker and better. The vibration sensor senses any vibration in the bridge. Normally all kinds of accidents cause some vibration. So vibration sensor monitors the occurrence of vibration. LDR sensor is used to monitor the bridge lights. Here temperature sensor is also used to monitor the heat in the bridge, as an increase in heat of cables in the bridge can lead to fire accidents, and a fire sensor is used to detect fire.

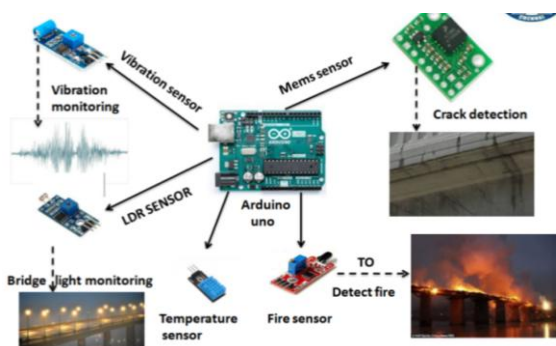


Figure1.Bridge Monitoring System

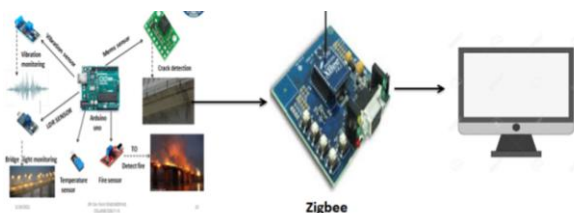


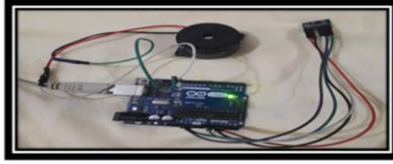
Figure 2.Storing the values in a PC.

### 4. Design Module

#### 4.1 Detecting the image of the cracks is given below

Micro Electro Mechanical Systems(MEMS) basically works with axis and measuring the angles. The X, Y, Z-axis angles are fixed. Cracks occur due to accidents, poor maintenance, or even due to heavy load and overstrain. If any type of crack occurs

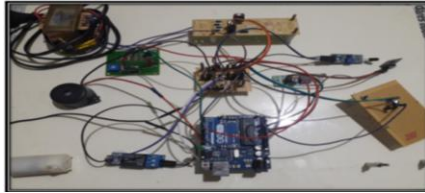
there will be some change in the angles. If any change occurs the mems sensor will sense the change in angle and indicates using a buzzer.



**Figure 3.** Micro Electro Mechanical Systems

*4.2 Vibration observing and light monitoring image is given below:*

First, for observing vibration, a vibration sensor is used. If vibration occurs beyond the threshold value, the LED indicator indicates the user. The values are transferred to the user through a wireless communication Zigbee. Then to monitor the bridge lights LDR sensor is used. This sensor works by digital signals. If there is some problem with bridge lights it will indicate the user by GSM message.



**Figure 4.** Zigbee

*4.3 Heat checking and fire sensing*

Heat checking is done by the temperature sensor. It senses any increase in heat and indicates the user by GSM message. A fire can be detected using a fire sensor. If there is any occurrence of fire the sensor senses it and immediately the pump motor is turned on.

*4.4 Wireless data transfer*

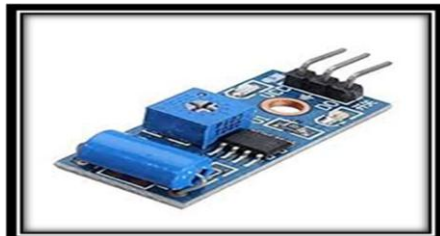
The readings and values detected using all the sensors are transmitted using a wireless transmitter Zigbee to the pc. The user can get the values from the pc.

*4.5 Hardware components*



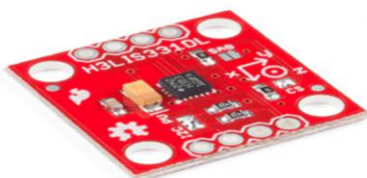
**Figure 5.** Arduino UNO

It comes under an open-source electronics platform based and it is easy-to-use hardware and software. To read inputs - light on a sensor with the help of Arduino boards. It is a great tool for developing interactive objects, by taking inputs from a variety of sensors or switches and controlling a variety of lights, motors, and other outputs. They can be connected to a computer using USB or the projects can be stand-alone.



**Figure 6.** Vibration sensor

It is a device to measure the frequency of vibration in a given system, piece of equipment, or machine. Where these measurements can be used to detect imbalances or other issues in the asset. And to predict the future defect. If a vehicle meets with an accident immediately Vibration sensors detect the signal. Where these sensors are flexible devices that are used for measuring various processes. It measures the changes within acceleration, pressure, temperature, force.



**Figure 7.** Mems Sensor

It is known as a Micro-Electro-Mechanical System. It is a process or technology used to create tiny integrated devices or it is a system that combines electrical and mechanical components. It provides the convenient features that you can get with any other sensor line such as analog voltage, current, and digital output options. To detect the cracks using a mems sensor by measuring the angle deviation continuously and to give an alert.

## 5. Conclusion

The proposed system “Automatic Bridge Monitoring System Using IoT”, is useful to society as it checks the strength of the bridge, any variations intimated and save the lives of passengers on the bridge, has been successfully implemented and testing is done and verified. In this system, we use many sensors like a mems sensor, vibration sensor, fire sensor, temperature sensor. So, it is very beneficial. Mostly these sensor used separately in the existing system but we have accommodated all sensors together, with the addition of GSM, LDR sensor, pump motor .where the GSM message can be

transacted directly to the Municipal Corporation to rectify the problem easily and So, it is being efficient for diagnosing to prevent from undesirable consequence. It is a preventive treatment for failure due to accidents.

## References

- [1] Seno AdiPutra; Bambang Riyanto Trilaksono; Muhammad Riyansyah; Dina Shona Laila, Multiagent Architecture for Bridge Capacity Measurement System Using Wireless Sensor Network and Weight in Motion, IEEE Transactions on Instrumentation and Measurement vol:70, 2020
- [2] Yanyan Fan; Zhenzhen Yang; Ziqi Li; Research on Fire Risk Assessment and Control Methods for Urban Bridges Based on Fuzzy-Bn . 12th International Conference on Measuring Technology and Mechatronics Automation (ICMTMA) ,2020
- [3] Thomas J. Matarazzo ; Paolo Santi ; Shamim N. Pakzad ; Kristopher Carter ; Carlo Ratti; Crowdsensing Framework for Monitoring Bridge Vibrations Using Moving Smartphones Sci. (ICAMS), 2010 IEEE Journal, vol. 106, 2018.
- [4] Cheng-Ta Chiang. Design of a CMOS MEMS Accelerometer Used in IoT Devices for Seismic. IEEE Int. Detection. Conf., vol. 8, 2018.
- [5] YuePeng-cheng, Research on the strain acquisition system of expressway bridge. First, International Conference on Electronics Instrumentation & Information System (EIS). vol: 70, 2017.
- [6] Ambeth Kumar.V.D .Precautionary measures for accidents due to mobile phone using IOT. Clinical eHealth, Volume 1, Issue 1, March 2018, Pages 30-35.
- [7] Ambeth Kumar.V.D (2018). Novel Wireless Sensing System For The Welfare Of Sewer Laborers. Healthcare Technology Letters (IET) Volume 5, Issue 4, p. 107–112.
- [8] Ambeth Kumar.V.D, Saranya.G , D.Elangovan, V.RahulChiranjeevi, V.D.Ashok Kumar. IOT Based Smart Museum Using Wearable Device. Lecture Notes in Networks and Systems, Vol.55, pp: 33-42, 2018
- [9] K. Nanagasabapathy; G. Harish; O. I. Allen Sebastian; N. Sowrabh Chandra; V. D. Ambeth Kumar, "Validation system using smartphone luminescence", IEEE International Conference on Intelligent Computing, Instrumentation and Control Technologies (ICICT), Pages: 235–239, 2017. DOI: 10.1109/ICICT1.2017.8342566
- [10] B. Aravindh; V.D.Ambeth Kumar; G. Harish; V. Siddarth, "A novel graphical authentication system for secure banking systems", IEEE (ICSTM), Pages: 177–183, 2-4 Aug. 2017, DOI: 10.1109/ICSTM.2017.8089147
- [11] R. Subha Shini et.al., "Recurrent Neural Network based Text Summarization Techniques by Word Sequence Generation", IEEE International Conference on Inventive Computation Technologies (ICICT), 2021, DOI: 10.1109/ICICT50816.2021.9358764
- [12] V.D.Ambeth Kumar et.al., "An Efficient Security System for Data base Management from Illegal Access, IEEE International Conference on Wireless Communications, Signal Processing and Networking, 2016. DOI: 10.1109/WiSPNET.2016.7566252



# Detection of Body Movement for Comatose Patient Using IoT

Nisha.Y<sup>a,1</sup> and K.Valarmathi.<sup>b</sup>

<sup>a</sup>PG Scholar, Dept of CSE, Panimalar Engineering College, Chennai, India

<sup>b</sup>Professor, Dept of CSE, Panimalar Engineering College, Chennai, India

**Abstract.** Coma is the state of anesthetized or unconscious state where the patient doesn't respond to the actions or any activities. Since the patients are in unconscious state the patients at tender or the doctors don't have time to observe the patient activities continuously. In order to overcome this problem an IoT based system is designed to monitor the body movements and the actions of the coma patient using various sensors. The equipment has been planned that utilizes Arduino controller board. In addition with the Arduino board various sensors have been associated through the controller board interface. The sensors values will be transferred to the cloud server. The movement of eye ball retina and motion of the body detected by the wearable motion sensors state are monitored. By using the sensors it is helpful for the doctor and the specialist about the well-being condition of the patients and continuously monitoring their physical condition. The challenging task is focused on the limitation of the existing techniques are discussed.

**Keywords.** IOT, Arduino controller, sensor, cloud server, sensors.

## 1. Introduction

Coma is a state of oblivion in which a human being cannot be awoken; fail to take action on average to agonizing stimuli, light, or sound; lacks abnormal wake sleep cycle, and does not begin voluntary actions. Coma might occur for several reasons, such as intoxication, a disease or infection that affects the central nervous system (CNS), a serious injury, and hypoxia, or oxygen deficiency. Doctors will monitor the activity of the patient continuously in order to find the improvement in patient health. Also they will monitor the coma person's body movements and position, response to painful health status or stimuli, and pupil size. Doctors will monitor and observe the nasal breathing pattern that helps in diagnosing the cause and reason of the coma.

---

<sup>1</sup> Y.Nisha, PG Scholar, Dept of CSE, Panimalar Engineering College, Chennai, India,  
E-mail: nishayuva4@gmail.com

In order to determine the coma affected person's stage of consciousness. Doctors will regularly monitor the signs of arousal, such as voice, vocal noises, eyes pupil motion or movement. And also will test and test the reflexive eye actions. All these tests may help in finding out the cause of the coma and the spot or the region of brain failure or damage. The system has been designed such that the patient under the treatment is completely under surveillance so that all the information of the patient is directly stored in the server. For monitoring the patient physically it is usually happening in hospitals where two or three hospital staff needed to monitor the patient 24\*7 for surveillance if there is movement or not, but this is not well-organized method to get maximum efficiency. So this project helps to monitor the patient physically for every moment. The system is developed based on motion Flex sensor, Eyeball pupil sensor, MEMS or accelerometer body sensor, Heartbeat rate sensor, Temperature sensor and the Pressure sensor which is used to develop and design a system that will monitors the body movement of the person at coma stage and alerts automatically if any abnormal activity occurs by sending a message to the respective person using IOT.

## **2. Related works**

K.Vishwanatha [1] has proposed a model that is reliable, precise and smart with robust algorithm that helps in monitoring the motion detection of the patient. This system uses algorithm called as background subtraction. A portable system that consist of a test kit which associates in detection of eye blink for comatose patient was developed by [2]V.Subharamya This system provides the physical health monitoring phase. ShwetaS.kshirsagar[3]enabled a model that provides the interaction sensors and the cloud server. It provides an communication module to the patient who is in coma and the relative of the patient about the health status of the patient. A model has been developed in order to detect the changes of the patient who is in the comatose state.Yuvaraju.M and priyanka.R [4] has suggested the model based on the flex sensors. A study has conducted in the year of 2013 by GuhaBalakrishnan[5].this system extracts the heart beat rate and analyze the rate by Newtonian method. Also this captures the data clinically and sends the data to the cloud system. A study conducted in the year of 2020 based on the development of Multi-parameter system for detecting patient health monitoring system by Athira.A et al [6]. Zakir Husain et al [7] has designed a system that helps in continuous monitoring of the health status of the comatose patient based on the internet of things .the abnormal movement captured in acutely ill patient with the major brain injuries. Muhammad Naufal Bin Mansur et al [8] has proposed a system using K-NN and LDA algorithm for expression analysis under different lighting for coma patients. Naveen Kansal, Hardeep Singh Dhillon[9]developed a system that provides the interface between the sensor hub and the cloud server all the data of the patient are controlled and preserved for the emergency situations.V. Ferrari[10]enabled a system that helps in acting as a tool for monitoring the coma patient viral parameters such as heart rate, pulse rate and all the day will be stored in the cloud server. If the system reaches the threshold value then the system will alert through the message or email [11-18].

### 3. Methodology

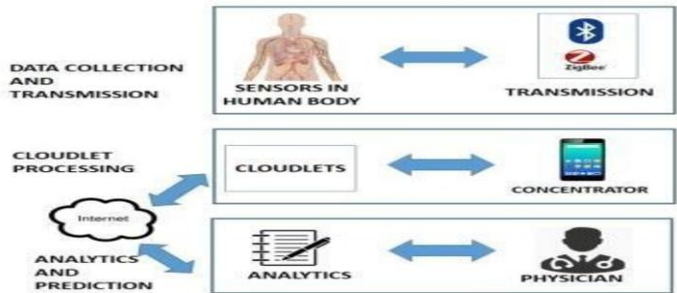


Figure 1. Proposed System Framework

Figure 1 represents the overall proposed system framework. The health monitoring system proposed consists of several and variety of sensors that are alienated into two categories. The first category is mainly used in order to monitor the vital signs of the coma patient and second component is mainly used in order to detect the changes physically that occurs in the coma patient. In this system, temperature, heart rate, movement of the patient, blood pressure are the major vital information that has been monitored, preserved and recorded in order to be aware of status of a health of coma patient. The FLEX sensor and PIR sensor are mainly used for in order to detect the changes bodily like movement of the body that occurs in a coma patient body. All these signals helps in providing the information that are recorded and monitored continuously in order to understand the functioning of the body. ECG Sensor is mainly used to monitor the of heart beat. If the signals are sensed which are outside the threshold value or the normal values ranges naturally that implies the need for emergency care or possible evacuation to provide a higher level of treatment during which the system alerts the care taker and also the doctor.

### 4. Data flowdiagram

#### 4.1 Level 0

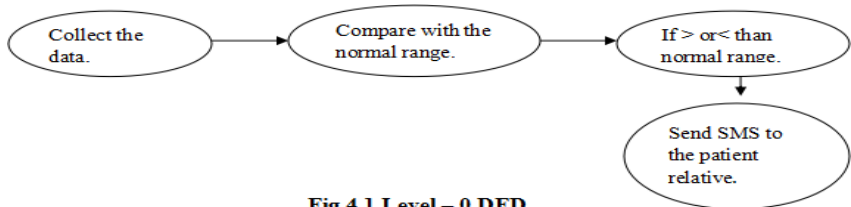


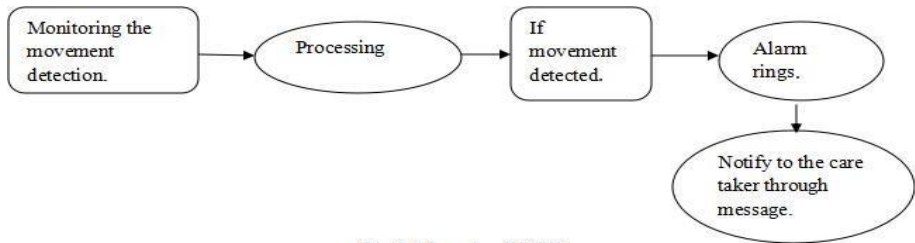
Fig.4.1 Level – 0 DFD

Figure 2. Level – 0 DFD

The figure 2 shows the DFD diagram for level 0. This DFD level 0 diagrams represents the complete process of the system. This diagram represents collection of data from the

sensor to the IOT board .these data are processed in the microcontroller and then if any abnormal range occurs then it will immediately send the message to the respective patient relative.

#### 4.2 Level 1



**Fig.4.2 Level – 1 DFD**

**Figure 3.** Level – 1 DFD

The figure 3 represents the Level – 1 DFD which extends the process of movement detection. The sensor data is given as an input to the system where it is processed and then monitors the changes in the movement of the body. If any changes occur in the body then the data is updated in the database and also the alarm is received to the care taker.

## 5. Conclusion and futurework

The endeavor of our planned system is to build easily easy to get to design that the patient's information is stored and easily monitored by the doctors and staff. This planned model helps in several ways that can be easily retrieve the data of the patient that has been stored in the server. So this system provides the maximum efficiency and high throughput. All the critical information of the patient is conveyed quickly to the doctor is achieved. The designed model leads to the better and effective health care service to comatose and the collected data is networked worldwide with the help of internet and communication which provide a quickresponse.

## References

- [1] K. Vishwanatha ,Murigendrayya M. Hiremath, Advances Motion Detection Algorithm for patient monitoring using cell phone with video display, international journal of electronics signals and systems volume 2 ,issue 3.
- [2] V.SubhaRamya,AmeerVilangali, portable test kit for coma patient with eye blink alert system, International Journal of Advanced Research in Electrical, Electronics and Instrumentation engineering.vol.7,issue4.
- [3] ShwetaS.Kshirsagar,P.A.Ghone, Movement detection using image processing, International Journal of Science and Research (IJSR) Volume 4 Issue 2, February2015.
- [4] Yuvaraju.M and priyanka.R, Flex sensor based gesture control wheelchair for stroke and SCI patients, International Journal Of Engineering Sciences & Research Technology,May2017.

- [5] GuhaBalakrishnan,FredoDurand,JohnGuttag .Detecting pulse from head motions in video. IEEE xplore vol23,issue3.
- [6] Athira.A, Devika.T.D, Varsha.K.R, SreeSanjanaaBose.S .Design and Development of IOT Based Multi Parameter Patient Monitoring System. International Conference on Advanced Computing & Communication Systems,2020.
- [7] ZakirHussain, Ravindiran, Health Monitoring System for Comatose Patients: A Survey, International JournalofAdvanceResearch,IdeasandInnovationsinTechnology, Volume 3, Issue6,2017.
- [8] Muhammad Naufal Bin Mansur, Smart Health Monitoring Systems: An Overview of DesignandModeling , Journal of Medical System, Vol.37,2013.
- [9] Naveen Kansal, Hardeep Singh Dhillon, Advanced Coma Patient Monitoring System, International Journal of Scientific & Engineering Research Volume 2, Issue6.
- [10] V. Ferrari, T. Tuytelaars, and L. V. Gool, Real-time affine region tracking and coplanar grouping, in Proc. IEEE Conf. on Computer Vision and Pattern Recognition, Hawaii, vol. II,2001.
- [11] V.D.AmbethKumar ,S.Ramya , H.Divakar , G.KumuthaRajeswari .A Survey on Face Recognition in Video Surveillance. Lecturer Notes on Computational and Mechanism, Vol. 30, pp: 699-708, 2019
- [12] Ambeth Kumar.V.D .Precautionary measures for accidents due to mobile phone using IOT. Clinical eHealth, Volume 1, Issue 1, March 2018, Pages 30-35.
- [13] Nanagasabapathy.K ,G. Harish; O. I. Allen Sebastian; N. Sowrabh Chandra; V. D. Ambeth Kumar. Validation system using smartphone luminescence.IEEE International Conference on Intelligent Computing, Instrumentation and Control Technologies (ICICT), Pages: 235 – 239, 6-7 July 2017, Kannur, India
- [14] Ambeth Kumar.V.D, V. D. Ashok Kumar; H. Divakar; R. Gokul. Cloud enabled media streaming using Amazon Web Services. IEEE International Conference on Smart Technologies and Management for Computing, Communication, Controls, Energy and Materials (ICSTM), Pages: 195 – 198, 2-4 Aug. 2017, Vel Tech University, Chennai, India (DOI: 10.1109/icstm.2017.8089150)
- [15] Aravindh.B, V.D.Ambeth Kumar; G. Harish; V. Siddarth. A novel graphical authentication system for secure banking systems .IEEE International Conference on Smart Technologies and Management for Computing, Communication, Controls, Energy and Materials (ICSTM), Pages: 177 – 183, 2-4 Aug. 2017, Vel Tech University, Chennai, India
- [16] Ambeth Kumar.V.D et.al, (2016).An Efficient Security System for Data base Management from Illegal Access. IEEE International Conference on Wireless Communications, Signal Processing and Networking (WiSPNET), SSN Engineering College, Chennai, India, 23-25 March, 2016
- [17] Ambeth Kumar.V.D and Dr.M.Ramakrishan (2011).Web Cam Motion Detection Surveillance System Using Temporal Difference and Optical Flow Detection with Multi Alerts. (CCIS) Journal (Springer) Volume 147, Part 3,pp: 214-221, 2011, April 2011 and the paper was published in the International Journal. [Impact Factor: 0.247].[DOI: 10.1007/978-3-642-20573-6\_34]
- [18] Ambeth Kumar.V.D and Dr.M.Ramakrishan (2012) .Enhancement in Footprint Image using Diverse Filtering Technique. in the month of March for the Procedia Engineering journal (Elsevier) Journal Volume 8, No.12, 1072-1080, March 2012 and the paper was published . [doi:10.1016/j.proeng.2012.01.965]
- [19] R. Subha Shini et.al., “ Recurrent Neural Network based Text Summarization Techniques by Word Sequence Generation”,IEEE International Conference on Inventive Computation Technologies (ICICT), 2021, DOI: 10.1109/ICICT50816.2021.9358764
- [20] S.V. Ruphitha et.al, “ Management of Major Postpartum Haemorrhage by using Zigbee protocol - A Review “, 2021 6th International Conference on Inventive Computation Technologies (ICICT) (DOI: 10.1109/ICICT50816.2021.9358757 )
- [21] M. Indhumathi et.al , “Healthcare Management of Major Cardiovascular Disease-A review”, 2021 6th International Conference on Inventive Computation Technologies (ICICT), (DOI: 10.1109/ICICT50816.2021.9358519 )
- [22] .K. Sabarinathan et.al ., “ Machine Maintenance Using Augmented Reality”, 3rd International Conference on Communication and Electronics Systems (ICES), 2018. (DOI: 10.1109/CESYS.2018.8723900)

# Deciding Bank Client's Credit Limit and Home Loan Using Machine Learning

Ganga A<sup>a,1</sup>, Vijayalakshmi S<sup>b</sup>, Ms Kalpana R A<sup>b</sup>,

<sup>a</sup>*Assistant Professor, Dept of CSE, Sri Sairam Engineering College, Chennai, India*

<sup>b</sup>*UG Scholar, Dept of CSE, Sri Sairam Engineering College, Chennai, India*

**Abstract.** Bank customer's profile helps the bankers to whom the banking facilities may be given and what credit limit to produce. The profile includes both demographic and transaction data. By the best technique, the exactness might be accomplished and furthermore the banks can get higher gainfulness by fulfilling the purchasers. The various data analytic techniques are used for the credit limit prediction and the loan amount for that credit limit is also determined. The regression algorithms are employed for improving high accuracy in predicting the credit card limit.

**Keywords.** Regression, Demographic data, Transaction Data

## 1. Introduction

A Credit Card may seem like simply one more device which assists you with making buys, however it without a doubt can accomplish such a great deal more. Whenever utilized dependably, a Credit Card can help you fabricate a decent record as a consumer, additionally permitting you to get advances at good Interest Rates. It also helps you earn reward points on your everyday purchases which can be redeemed for Gifts, vouchers, flight tickets etc. Credit Card also has host of offers on various categories like Travel, Dining, Shopping, Bill payments etc. Credit Card is safer for Online & Store purchase as the transactions are authenticated using PIN or OTP. While assessing a home advance application, banks or loan specialists, figure a candidate's getting capacity dependent on his/her credit limit. Fundamentally, when you apply for an advance, the bank takes a gander at different subtleties to check in the event that you have the capacity to reimburse. Banks will likewise attempt to break down the level of hazard implied in giving you a credit. The components considered to evaluate reimbursement capacity incorporate compensation, securities, age and record as a consumer. With regards to financial record, your charge card assumes an immense part. On the off chance that your record as a consumer is acceptable, you will be considered a 'acceptable danger' and will be conceded an advance. Although, some studies revealed statistical information about the home loan approval via credit card limits.

---

<sup>1</sup>Ganga. A, Assistant Professor, Dept of CSE, Sri Sairam Engineering College, Chennai, India;  
E-mail: ganga.cse@sairam.edu.in

The methods like Regression, AdaBoost algorithm, XGBoost algorithm, Stochastic Gradient Descent algorithm are intricated to develop the project to its higher level of accuracy. The proposed framework can improve bank customer's behavior using machine learning algorithms such as regression and classification. Here the credit card limit with house loan is predicted and a series of pre-processing for converting the raw data to useful data is done, so that it will increase the execution time as well as the accuracy of the model. The algorithm analysis for both the model with regression and classification algorithm is being done and found the best fittest algorithm for the model.

## 2. Related Works

Using different approaches and datasets, a number of experts are tackling the problem of profiling bank clients. In 2015, Using two stages and k-implies clustering algorithms, a characterization model for the dataset of Sepah Bank Branches in Tehran was introduced by Sharahian and Aligholi[2]. Division of 60 organizations, which were clients of Sepah Bank was a sort of segment and conduct division and it helped to distinguish the loyal customers. In 2016, Ayoubi[3] clarified a client division model dependent on the two-venture calculation and Kohonen neural organization. In 2017, Palaniappan et al.[4] introduced a profiling model for the clients of a Portuguese retail bank inside the duration of five years (2008 to 2013). This paper zeroed in on assisting manages an account with expanding the exactness of their client profiling through characterization just as distinguishing a gathering of clients who had a high likelihood to buy in a long haul store. Three grouping calculations were utilized which were Naïve Bayes, Random Forest and Decision Tree. In 2017, Bansalet al. [5] introduced an alteration in a bunching model of the k-implies calculation. In 2017, Patil and Dharwadkar[6] produce forecast and characterization model for two datasets of bank client's information.[7-8]

## 3. Existing System

The primary thought of our proposed model is to improve profiling bank client's conduct utilizing distinctive AI procedures. This model beginnings with the dataset, which acquired from the UCI AI vault. At that point information goes through the progression of information preprocessing. From that point forward, the AI procedures are applied to fabricate the client profile. In AI, the profiling stage perceives the things in a gathering and places them under target classes. In this paper, the precision pace of strategies is assessed through Gini co-effective for the solo methods at that point utilized the outcomes as contribution for regulated procedure (Artificial Neural Network) (ANN) at that point assesses their results to contrast them with get the best strategy.

#### 4. Proposed System

The proposed framework is used to improve bank client's conduct utilizing AI calculations such as regression and classification. In this model the credit card limit and house loan is predicted for the particular location in India. A series of pre-processing is done for converting the raw data to useful data. The various regression algorithms like linear regression ,decision tree, random forest regression and SVM is used in credit limit model and the accuracy of the algorithms is found. Similarly, the classification algorithms like logistic regression decision tree, naïve bayes classification, svm are used in loan prediction model and accuracy of the algorithms.

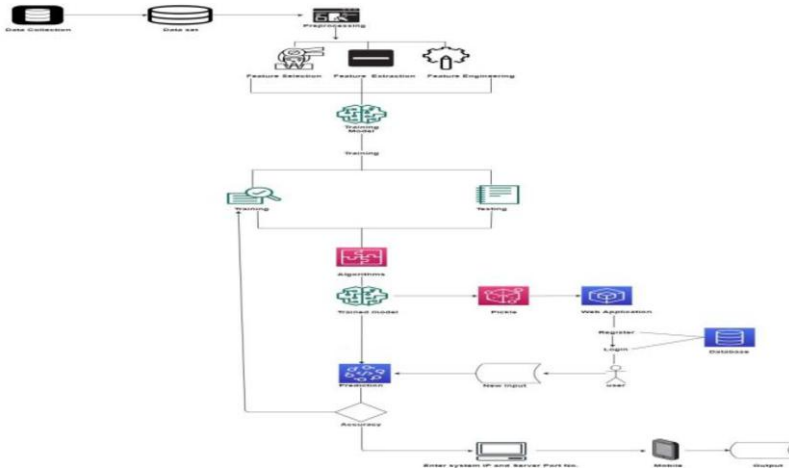


Figure 1. The proposed model for profiling bank customers

#### 5. Methods Used

##### 5.1. Naive bayes theorem

This learning model applies Bayes rules through autonomous highlights. Each example of information D is assigned to the class of most noteworthy resulting likelihood. In AI, it is frequently keen on choosing the best speculation (h) given information (d). The theory (h) may be the class to relegate for another knowledge case in a grouping problem (d). Perhaps the simplest method of selecting the most likely hypothesis provided the information available, which can be used as previous information about the question. The Bayes' Theorem explains how to calculate the probability of a hypothesis based on previous data.  $P(h|d) = \frac{P(d|h) * P(h)}{P(d)}$  is Bayes' Theorem's formula (d) P(h|d) denotes the probability of speculating h given the knowledge d. The back probability is a term used to describe this situation.

##### 5.2. Decision tree Algorithm

A decision tree is developed by recursive parceling Starting from the root, the information is part on the element that outcomes in the biggest Information Gain (IG)



(clarified in more detail beneath). In an iterative interaction, we at that point rehash this parting technique at every youngster hub until the leaves are unadulterated — for example tests at every hub all have a place with a similar class. Here, our target work is to augment the data acquire at each split, which we characterize as s:

$$IG(D_p, f) = I(D_p) - \left( \frac{N_{left}}{N_p} I(D_{left}) + \frac{N_{right}}{N_p} I(D_{right}) \right)$$

### 5.3. Random Forest

Random forest, also known as random decision forests, is a group learning technique for order, relapse, and other tasks that involves creating a large number of option trees over a period of time and determining the class that is the method of the classes (characterization) or mean expectation (relapse) of the individual trees.

### 5.4. Support Vector Machine

A SVM model is a representation of the models as focuses in space, with the instances of the various classes separated by an unmistakable hole as large as is reasonably possible. Planned new models with same space and are expected to have a designation based on which side of the hole they fall on. In addition to performing direct characterization, SVMs may also play out a non-direct arrangement using what is known as the component stunt, effectively designing their contributions to high-dimensional element spaces. When unlabeled information is there, regulated learning is impossible, so a solo learning method is needed, in which the goal is to discover common groupings of information and then map new information to these framed groups.

### 5.5. Linear Regression

Linear Regression is an AI calculation dependent on managed learning. Direct relapse depicts the task of predicting the value of a reliant variable (y) in light of a provided autonomous variable (x). In this way, this relapse protocol discovers a direct link between x (input) and y (output). The name will now be Linear Regression.. In the graph, X (input) is the work insight and Y (yield) is the compensation of an individual. The relapse line is the best fit line for our model.  $Y = \Theta_1 + \Theta_2 X$

### 5.6. Logistic Regression

The logistic potential, which is at the heart of the strategy, is named after logistic regression. Analysts developed the logistic capacity, also known as the sigmoid capacity, to represent properties of population growth in nature, such as rapid growth and maximization at the climate's transport limit.

## 6. Implementation

### Module-1 Data collection and preprocessing

Data collection is the process of collecting details about the bank clients with credit transaction with personal details like Age, City, Segment, income, card type, etc.

Preprocessing is the process of removing the incomplete, inconsistent, incorrect and null data of the dataset. After the selection of the features we will use that data to train our model.

#### Module – 2 Credit Card limit Model

This module for credit card limit is used to predict the credit card limit of the bank clients using various regression algorithms and also the best accuracy of the algorithm is found in request to build up the model for prediction. After the preprocessing of the data, the dataset is used for training. The dataset is split as features and label after then it is used for training the model. The different regression algorithm like random forest regression, decision tree, linear regression, and support vector regression algorithms are analyzed. Finally, which algorithm has greater accuracy will be used for final model and the result of this module is used, in order to predict the loan of the predicted card limit.

#### Module-3 Loan prediction Module

After creating the credit card limit modules, the preprocessed loan dataset is used for training. The dataset is split as features and label, after that we will use that for training the model. Here ensemble modules are used in order to predict the result. In this module supervised learning is used for the classification of loan prediction thus, many classification algorithms are present, here we using logistic regression because comparing with other algorithms it gives more accuracy. Finally the algorithm with greater accuracy is used for developing the model for prediction of loan.

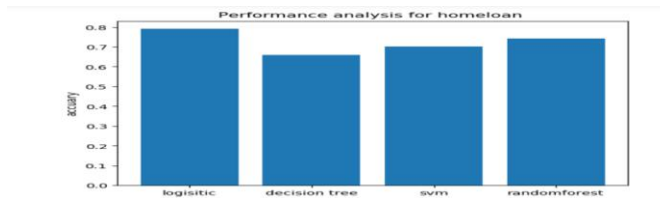


Figure 2. Module-4 Interface with UI

After the creation of model for loan and credit limit. The web application is created to see the prediction results but the machine learning and Web development is different domain so the pipeline for interacting machine learning and web application model using the pickle package is created. After that user can give input and can get the output results.

## 7. Future Scope

The executives of credit limits is quite possibly the most basic choices identified with Master card accounts. It influences various factors that have immediate or circuitous effect on the productivity. Supervised learning showed higher accuracy rate in determining credit limit and home loan. The accuracy in predicting the home loan can be improved by using unsupervised learning algorithm in future.

## 8. Conclusion

Profiling of customer details helped the banks to form an interactive relationship with customers through trust. Banks get high profitability through the customer satisfaction. Supervised learning is employed for producing higher accuracy in determining credit card limit. Decision tree regression produced higher accuracy rate when compared to other regression algorithms. Based on the credit limit home loan can be predicted. The classification algorithms are used for home loan prediction in which logistic regression produced higher accuracy rate.

## References

- [1] M. Sharahi and M. Aligholi, Classify the data of bank customers using data mining and clustering techniques (case study: Sepah bank branches Tehran), *J. Appl. Environ. Biol. Sci.*, vol. 5, no. 5, pp. 458–464, 2015.
- [2] M. Ayoubi, Customer segmentation based on CLV model and neural network, *Int. J. Computer. Sci.*, vol. 13, no. 2, p. 31, 2016.
- [3] A. Arshad, S. Riaz, and L. Jiao, Semi-supervised deep fuzzy c-mean clustering for imbalanced multi-class classification, *IEEE Access*, vol. 7, pp. 28100–28112, 2019.
- [4] Ahram Online. Egypt's BanqueMisr Conditionally Suspends Card Usage Abroad Amid Currency Crisis. Accessed: Apr. 10, 2019.[Online].
- [5] Ambeth Kumar.V.D .Precautionary measures for accidents due to mobile phone using IOT. *Clinical eHealth*, Volume 1, Issue 1, March 2018, Pages 30-35.
- [6] Nanagasabapathy.K, G. Harish; O. I. Allen Sebastian; N. Sowrabh Chandra; V. D. Ambeth Kumar . Validation system using smartphone luminescence. *IEEE International Conference on Intelligent Computing, Instrumentation and Control Technologies (ICICIT)*, Pages: 235 – 239, 6-7 July 2017, Kannur, India
- [7] Ambeth Kumar.V.D,V. D. Ashok Kumar; H. Divakar; R. Gokul. Cloud enabled media streaming using Amazon Web Services. *IEEE International Conference on Smart Technologies and Management for Computing, Communication, Controls, Energy and Materials (ICSTM)*, Pages: 195 – 198, 2-4 Aug. 2017, Vel Tech University, Chennai, India (DOI: 10.1109/icstm.2017.8089150)
- [8] Aravindh.B, V.D.Ambeth Kumar,G. Harish, V. Siddarth. A novel graphical authentication system for secure banking systems. *IEEE International Conference on Smart Technologies and Management for Computing, Communication, Controls, Energy and Materials (ICSTM)*, Pages: 177 – 183, 2-4 Aug. 2017, Vel Tech University, Chennai, India
- [9] K. Sabarinathan et.al ., “ Machine Maintenance Using Augmented Reality”, 3rd International Conference on Communication and Electronics Systems (ICCES), 2018. (DOI: 10.1109/CESYS.2018.8723900)
- [10] R. Subha Shini et.al., “ Recurrent Neural Network based Text Summarization Techniques by Word Sequence Generation”,*IEEE International Conference on Inventive Computation Technologies (ICICT)*, 2021, DOI: 10.1109/ICICT50816.2021.9358764

# Detection of Ketosis in Bovine Using Machine Learning Techniques

Pushkala V <sup>a,1</sup> and Dr. S. Nirmala Devi<sup>b</sup>

<sup>a</sup>PG Scholar, Dept of ECE, College of Engineering Guindy, Anna University, India

<sup>b</sup>Professor, Dept of ECE, College of Engineering, Guindy, Anna University, India

**Abstract.** This paper presents the different unsupervised machine learning algorithms used for Ketosis detection, based on the color characteristics taken from the Ketocheck rapid colorimetric test. The level of ketone bodies in bovine's urine is represented by three color categories, range of dark green (right ketone level), green (normal range ketone level) and yellow/orange (higher ketone level). The color image is converted into HSV color space for better color discrimination. The proposed technique enables detection of ketosis by clustering every pixel in the image using unsupervised K-means clustering and Fuzzy C Means (FCM) clustering algorithms. The results obtained have shown that K-means algorithm is faster and it also have low computational complexity. Two android application is developed. One with K-means clustering algorithm loaded in server and the other, directly programmed in android application.

**Keywords:** Unsupervised machine learning, ketocheck, k-means clustering, fuzzy c means clustering, and android.

## 1. Introduction

Ketosis or Acetonaemia is a metabolic disorder occurs in bovine (cattle) during the first few weeks of lactation. It is characterized by elevated ketone bodies level in blood or urine and low blood glucose level. In late pregnancy, the energy requirement for the growing calf is high but the cow's appetite is reduced. This problem is identified during the moderate decline in milk yield and there might be sudden drop in some cases. Some other indications are weight loss, reduced appetite, waxy firm faeces, dull coat and nervous signs, aggression, lack of coordination and excess salivation. The article in Journal of Dairy Veterinary and Animal research suggests that one of the best methods to prevent ketosis is using blood, urine or milk screening for ketone bodies detection, which is simple to implement in cattle farms [1]. In this paper, the Ketocheck rapid colorimetric test kit is used to test the urine sample of the cattle to identify the level of ketone bodies, especially  $\beta$ -hydroxy butyrate (BHB). It is an affordable cow-side test for BHB detection and for It is an affordable cow-side test for BHB detection and for routine monitoring of herds. It cost only about 20% of the costs involved in commercial tests [2].

<sup>1</sup> Pushkala V, PG Scholar, Dept of ECE, College of Engineering, Guindy, Anna University, Chennai, India  
E-mail: 2019254040@student.annauniv.edu

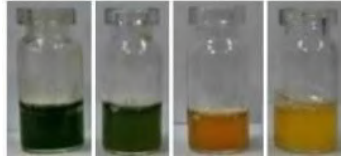
Unsupervised Machine learning (ML) is one of the best ways for predicting outcomes without being explicitly programmed and works without historical data or labeled responses. Color based segmentation for detecting different colors in the well-plate with 96 different urine sample to identify whether the bovine is infected by ketosis or not using clustering techniques. Unsupervised clustering algorithms namely, K-means and Fuzzy C means clustering are used. Android application with machine learning helps in easy access to the results of the ketosis test. Two android application is developed. One works with server containing ML algorithm and the other in which ML algorithm is directly programmed in the app.

## 2. Literature Review

Wolfgang D. Niño Pacheco et al, developed an unsupervised K-Means Clustering algorithm to segment six different colors of tomatoes that ranges from green to red. They have used  $L^*a^*b$  and HSI color spaces. The algorithm randomly picks the image from the dataset and the data points are clustered [10]. Srinivas B et al, segmented tumor from the MRI Brain images using the clustering algorithms, K- Means and Fuzzy C-Means (FCM). They converted RGB images to grayscale, used cluster size 3 and concluded that FCM takes lesser processing time [5]. Tamilselvi P et al, used K-means clustering and self-organizing map (SOM) to segment the infected leaves from the healthy ones. They used different histogram techniques to preprocess the leaf images and applied K-means algorithm to cluster the leaves based on the colors. City block technique gave high accuracy [8]. Jiwen Dong et al, detected the skin area by converting RGB images to LAB color space and applied K-means clustering. The tattoo area is segmented based on the area connectivity and concluded that this approach possesses low computation complexity [4]. Himanshu Yadav et al, used K-means algorithm for segmentation. The different cluster size from 2 to 5 is used. The results show that higher the cluster size, the results are more enhanced. They tested the algorithm with colored brain images and ultrasound images and concluded that the tumor is clearly noticeable [3]. Shoichi Araki et al, used FCM algorithm to segment thermal image of occupants in a room taken by a thermoviewer [11-13]. They distinguished occupants by measuring local temperature peaks from the image and determined the number of clusters [7]. Shiling Sun et al, data samples in the image are converted to gray-scale in order to reduce complex computation and FCM algorithm is applied to segment the image [6].

## 3. Ketosis Diagnostic Kit

Ketochek: The rapid calorimetric test kit is used to detect BHB in urine and is used for monitoring as cow side-test. The color of the urine changes when based on the amount of ketone bodies present. Higher the BHB in urine, the cow is surely infected. The colors that can be obtained from the test is shown in Figure 1. The respective BHB levels and results based on the colors are tabulated in Table 1. The test samples taken for processing is well-plated with 96 different urine samples which contains the three different categories of colors.



**Figure 1.** Color Category based on the amount of BHB in the urine

**Table 1.** Result Interpretation based on color changes in the urine sample

Color	BHB (mmol/L)	Result
Dark Green	0	Unaffected (-)
Green	< 2	Normal (+)
Orange/Yellow	> 2	Infected (++)

#### 4. Materials and Methods

##### a. Color Space Conversion

The algorithm reads the uploaded RGB (Red, Green and Blue) image and brightens it to enhance the colors. The RGB image is converted into HSV (Hue, Saturation and Value) color model by using OpenCV library. By converting the RGB image into HSV color space, the color (Hue) is separated from saturation and illuminance. So, the HSV color space is more suitable for color-based segmentation.

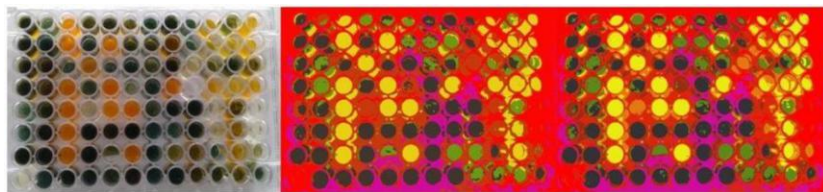
##### b. Machine Learning techniques

###### *K-means Clustering*

The unsupervised K-means clustering algorithm makes inferences from the live data with input vectors without referring to the known or labelled outcomes. The pixels in the image are considered as data points. The color component is used to group similar data points based on the cluster size. The new data point is allocated to the cluster that is closest to it. The centroid is modified each time when the algorithm reads a new data point.

###### *Fuzzy C Means Clustering*

In Unsupervised FCM clustering algorithm, each data point in the image is assigned partially to all the clusters in the input image based on the membership value.,the input vectors are not assigned exclusively to a single cluster, but partially to all the clusters. The membership value is higher, when the data point is closer to a particular cluster and that data point is assigned to the cluster with highest membership value. Figure 2 compares the input image with the segmented image obtained from K-means and FCM clustering.



**Figure 2.** Input Image vs K means Output vs FCM Output

## 5. Android Application

Mobile application is developed using Android Studio and python frameworks to segment the samples in the well plate image. The application developed for android users is easy to use and provide instant results without having to undergo any complex screening process to identify the results.

### *a. On-device Machine Learning Application*

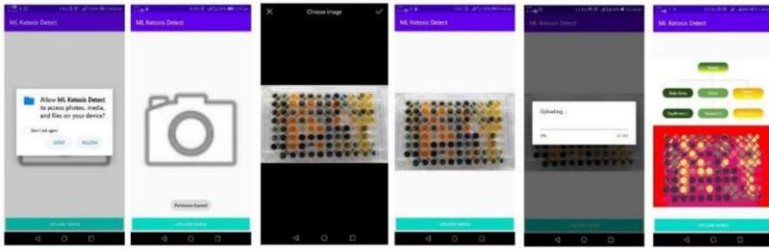
The machine learning algorithm is directly programmed onto the android application. The device does not need internet access to operate the application or to view the results. Figure 3 illustrates the working of the application. The user install the application and grant permission to access media files from storage. Click 'CHOOSE IMAGE' button to select the image. Click 'KETOSIS KMEANS' button multiple times to display the clusters one after the other. The result description is also attached in the bottom of the page to identify respective category of the colors.



**Figure 3.** Working of On-device Machine Learning Application

### *a. Online Application*

Online application comprises two main modules, Android app and web server. The server is developed using Python Flask Framework. The device using the application should the internet access to transfer the images to and from the server through IP address and port number. Figure 4 illustrates the working of the online application.



**Figure 4.** Working of Online android application

## 6. Results and Discussion

The machine learning algorithm process the RGB color image with the goal of segmenting three categories of colors. With the help of unsupervised clustering algorithm, the range of a particular color can be grouped forming the single-color cluster. For processing and examination, 15 images of a well-plate with 96 urine samples are taken. There are two clustering methods used. Cluster size 6 is fixed in K-means and FCM clustering, and it can clearly segment the three-color groups. While comparing the results obtained by working with RGB and HSV color space, clustering algorithm applied on RGB image ends up separating dark green and green as a single color. HSV color space increases the accuracy of the algorithm by enhancing the hue of the image. Although these clustering algorithms yield the expected result, one main consideration is to launch the algorithm in the android application. The faster the app works, the better the user experience will be. The K-means clustering algorithm takes no more than 3 seconds to complete, while FCM clustering takes up to 75 seconds.

## 7. Conclusion

The urine sample color images are taken as input and segmented into three colors. Two unsupervised machine learning algorithms are used. K-means and FCM clustering. According to the observation made, K-means clustering algorithm is faster than FCM and is implemented in the android application. The algorithm detects Infected, normal and unaffected bovine from the urine samples obtained through KetoCheck rapid test kit. The android application designed with and without server serves the user according to their internet accessibility.

## References

- [1] Madresheh-Ghahfarokhi, S., Dehghani-Samani, A., Dehghani-Samani, A. Ketosis (acetonemia) in dairy cattle farms: Practical guide based on importance, diagnosis, prevention and treatments, *Journal of Dairy, Veterinary & Animal Research*, vol. 7(6), pp. 299-302 (2018)
- [2] Sabapathy, Y., Maruthanayagam, A., Subramanian, U., & Gopal, D. R.: Validation and field application of in-house developed ketosis diagnosis kit, *The Pharma Innovation Journal*, vol. 7(7), pp. 937-939 (2018)



- [3] Yadav, H., Bansal, P., & Sunkaria, R. K.: Color dependent K-means clustering for color image segmentation of colored medical images. In 2015 1st International Conference on Next Generation Computing Technologies (NGCT), pp. 858-862. IEEE (2015)
- [4] Dong, J., Qu, X., & Li, H.: Color tattoo segmentation based on skin color space and K-mean clustering. In 2017 4th International Conference on Information, Cybernetics and Computational Social Systems (ICSS), pp. 53-56. IEEE (2017)
- [5] Srinivas, B., & Rao, G. S.: Unsupervised learning algorithms for MRI brain tumor segmentation. In 2018 Conference on Signal Processing And Communication Engineering Systems (SPACES), pp. 181-184. IEEE (2018)
- [6] Sun, S., Yan, S., Wang, Y., & Li, Y.: Brain MRI image segmentation based on improved Fuzzy C-means algorithm. In 2016 International Conference on Smart City and Systems Engineering (ICSCSE), pp. 503-505. IEEE (2016)
- [7] Araki, S., Nomura, H., & Wakami, N.: Segmentation of thermal images using the fuzzy c-means algorithm. In [Proceedings 1993] Second IEEE International Conference on Fuzzy Systems, pp. 719-724. IEEE (1993)
- [8] Tamilselvi, P., & Kumar, K. A.: Unsupervised machine learning for clustering the infected leaves based on the leaf-colours. In 2017 Third International Conference on Science Technology Engineering & Management (ICONSTEM), pp. 106-110. IEEE (2017)
- [9] Thirunavukkarasu, M., Kathiravan, G., Kalaikannan, A., & Jebarani, W.: Prevalence of ketosis in dairy farms—A survey in Tamil Nadu. *Tamilnadu J. Vet. Anim. Sci.*, vol. 6(4), pp. 193-195 (2010)
- [10] Pacheco, W. D. N., & López, F. R. J.: Tomato classification according to organoleptic maturity (coloration) using machine learning algorithms K-NN, MLP, and K-Means Clustering. In 2019 XXII Symposium on Image, Signal Processing and Artificial Vision (STSIVA), pp. 1-5. IEEE (2019)
- [11] Ambeth Kumar.V.D and Dr.M.Ramakrishan (2012).Enhancement in Footprint Image using Diverse Filtering Technique. in the month of March for the *Procedia Engineering journal (Elsevier) Journal Volume 8, No.12, 1072-1080, March 2012* and the paper was published . [doi:10.1016/j.proeng.2012.01.965]
- [12] Ambeth Kumar.V.D, Dr.M.Ramakrishnan, V.D.Ashok Kumar and Dr.S.Malathi (2015) . Performance Improvement using an Automation System for Recognition of Multiple Parametric Features based on Human Footprint. *kuwait journal of science* , Vol 42, No 1 (2015), pp:109-132.
- [13] Ambeth Kumar.V.D, Dr.S.Malathi, V.D.Ashok Kumar (2015) .Performance Improvement Using an Automation System for Segmentation of Multiple Parametric Features Based on Human Footprint. for the *Journal of Electrical Engineering & Technology (JEET)* , vol. 10, no. 4, pp.1815-1821 , 2015.[<http://dx.doi.org/10.5370/JEET.2015.10.4.1815>]
- [14] K. Sabarinathan et.al ., “ Machine Maintenance Using Augmented Reality”, 3rd International Conference on Communication and Electronics Systems (ICES), 2018. (DOI: 10.1109/CESYS.2018.8723900)
- [15] R. Subha Shini et.al., “ Recurrent Neural Network based Text Summarization Techniques by Word Sequence Generation”,IEEE International Conference on Inventive Computation Technologies (ICICT), 2021, DOI: 10.1109/ICICT50816.2021.9358764

# Underwater Image Enhancement and Fish Detection

I. Nelson<sup>a,1</sup>, C. Annadurai<sup>b</sup>, Shriram Venkatasubramani<sup>b</sup>, Yogesh.I<sup>c</sup> and Shrinivas Badri.S<sup>c</sup>

<sup>a 1,b</sup> Associate Professor, Dept of ECE, SSN College of Engineering, India

<sup>c</sup>UG Scholar, Dept of ECE, SSN College of Engineering, India

**Abstract.** The oceans cover over 70 percent of the surface of the earth. Underwater images are vital to explore these oceans, but they are impacted by quality degradation. The quality degradation occurs mainly due to absorption and scattering of light in water. Degradation in underwater images is caused by problems like low contrast, haziness, colour deviation and blurring. This in turn has made it difficult to explore, study and unravel the mysteries of the oceans. Good quality images are vital to study and research about existing marine ecosystems and also to discover numerous undiscovered species present underwater. There are various dehazing, restoration and enhancement techniques available to improve this scenario. We in this paper look to study and analyse the idea of building a system to combine some of the dehazing, restoration and enhancement algorithms available to obtain quality enhanced images. Further the system would also perform fish detection to obtain better accuracy using the enhanced images. We go about studying and analysing the image outputs obtained from individual algorithms and combination of algorithms and look to open up a possibility of further study of combining restoration and enhancement algorithms to improve the quality of images. We have proposed the idea of adding fish detection to this system as there has always been a difficulty of identifying and differentiating fish from other objects and marine life in underwater images. Doing so would help in studying about and even discovering new species. The fish detection models suffer from the image quality degradation problems and it impacts the accuracy. Hence, we have brought about the idea to enhance images to improve the efficiency and accuracy of fish detection. Therefore, we propose a system which would have various dehazing, restoration and enhancement algorithms working in tandem to produce an enhanced version of the input image. Next, the enhanced image is used to improve the accuracy of fish detection. Our review of combining restoration algorithms with enhancement algorithms and analysing the improvement in accuracy of fish detection by enhancing would provide researchers to further look into the opportunities available for improvement.

**Keywords.** Scattering, Absorption, Restoration, Enhancement, Detection.

---

<sup>1</sup>I.Nelson, Associate Professor, Dept of ECE, Sri Sivasubramaniya Nadar College of Engineering, India.  
E-Mail :nelson20@gmail.com

## 1. Introduction

Numerous problems are present in underwater imaging. Water firstly is much denser than air. This leads to reflecting back of light in water[6]. Then, the amount of light entering starts reducing as we go deeper into the ocean. The colours also start to drop off depending on the wavelength as we go deeper underwater[1]. Initially, at depths of 3-5m, red and orange colours start disappearing. At a further depth yellow colour disappears and then finally green and purple colours start to disappear. This is the main reason why underwater images have a low contrast. Different dehazing, colour restoration and enhancement techniques have already been proposed to improve the current situation. But, dehazing and colour restoration algorithms are only able to remove the basic haze in images. On the other hand, the enhancement algorithms provide improved contrast and visibility, but can cause colour distortions and also increase the noise present. Some of the other ideas proposed to improve the underwater image quality are too complex to implement in reality. Therefore, we have brought about the possibility of combining some of the existing dehazing, restoration and enhancement algorithms present to improve the overall image quality. In this paper we have analysed the effectiveness of the algorithms using a few image quality metrics. Different techniques and approaches have been proposed to detect fish[12]. Despite this, the accuracy of the model suffers if the quality of the image is low. Therefore, performing enhancement before detection would certainly improve the accuracy. We have performed fish detection using deep learning techniques. We have compared the effects of the different dehazing and enhancement algorithms on the accuracy of the fish detection model [13-14].

## 2. Proposed System

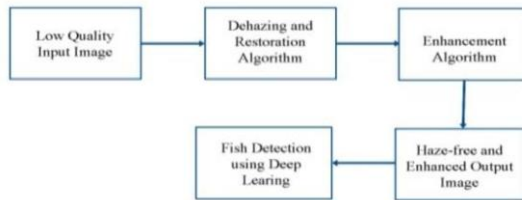


Figure 1.

## 3. Features of the Proposed System

### 3.1 Dehazing and Colour Restoration:

Algorithms tested and applied are:

- a] Dark Channel Prior (DCP) [2]
- b] Restoration based on Image Blurriness and Light Absorption (IBLA) [3]
- c] Underwater Light Attenuation Prior (ULAP) for Underwater Image Restoration [4]



#### 4. Quantitative and Qualitative Analysis:

We have used two full reference (PSNR and SSIM)[8] and two no-reference (NIQE and BRISQUE) image quality metrics for analysis.

##### 4.1 PSNR (*Peak Signal to Noise Ratio*):

A reference image is generally required which is treated as a ground truth image to calculate PSNR. Since we only have the distorted version of the image, it is used to compare with the enhanced version of the image to calculate the PSNR value. Higher the value of PSNR, lower is noise content and thus, higher the quality of image.

##### 4.2 SSIM (*Structural Similarity Index*):

This metric is a technique used to evaluate the similarity between two images. The value of SSIM varies from 0 to 1. If the value is 0, the images are dissimilar while a value of 1 means the given images are identical. Since we do not have ground truth image, the improved quality images are compared with the low-quality input images. We require a value closer to zero as it would indicate that there has been an improvement in the quality of images leading to dissimilarity between the images.

##### 4.3 BRISQUE (*Blind / Reference less Image Spatial Quality Parameter*):

This is a method which operates in the spatial domain and is a no-reference method quality assessment technique [9]. A default model is used to measure the quality of image. The lower the value, the better is the perceptual quality of the image.

##### 4.4 NIQE (*Natural Image Quality Evaluator*):

This method is another No reference method by collection of some statistical features based on a space domain natural scene statistic (NSS) model [10]. The quality of image is concluded to be better if the value of NIQE is lower. We have obtained better values of NIQE for the enhanced images when compared to the low-quality input images.

For the image, the DCP + ICM combination detects a greater number of fish accurately. Hence, despite obtaining much higher quality of images and improved fish detection accuracy from the system, it is difficult to identify the best performing combination of algorithms.

#### 5. Conclusion and Future Work

The system proposed in this paper has used existing algorithms and methodologies, but tries to combine them for much better results. The system opens up the possibility of being able to efficiently use combination of algorithms to obtain high quality underwater images which is useful for applications like fish detection. One drawback seen is the lack of efficiency of the image quality metrics. Despite the metrics helping us analyse

the quality of images, there is a lot of variation between them for different datasets, which makes it difficult for obtaining conclusive results and evidence. Hence, there is a major scope in the future to come up with better metrics for better analysis purposes. Since there are large variations in the performance of different algorithms depending on the characteristics of the input image, research could be made in the future to calculate parameters like depth at which the image was captured. This may lead to some complexity, but might help in analysing which algorithm combinations would produce a better-quality output image for a certain given input image. Hence, it is the need of the hour to be able to come up with effective systems and models to improve the quality of underwater images to be able to explore deep parts of the ocean in a much more efficient manner.

## References

- [1] Luz Abril Torres-Méndez and Gregory Dudek., Colour Correction of Underwater Images for Aquatic Robot Inspection. *Lecture Notes in Computer Science 3757*, Springer A. Rangarajan, B.C. Vemuri, A.L. Yuille (Eds.), pp. 60-73, 2005.
- [2] K. He, J. Sun, and X. Tang. Single image haze removal using dark channel prior. *IEEE Transactions on Pattern Analysis and Machine Intelligence.*, vol. 33, no. 12, pp. 2341–2353, Dec. 2011.
- [3] Peng.Y and P. C. Cosman. Underwater Image Restoration Based on Image Blurriness and Light Absorption .in *IEEE Transactions on Image Processing*, vol. 26, no. 4, pp. 1579-1594, April 2017.
- [4] Song.W, Y. Wang, D. Huang, and D. Tjondronegoro. A rapid scene depth estimation model based on underwater light attenuation prior for underwater image restoration. in *Advances in Multimedia Information Processing*, vol. 11164, R. Hong, W.-H. Cheng, T. Yamasaki, M. Wang, and C.-W. Ngo, Eds. Cham: Springer, pp. 678–688,2018.
- [5] Zuiderveld.K, Contrast Limited Adaptive Histogram Equalization, P. S. Heckbert, Ed. San Diego, CA, USA: Academic, pp. 474–485,1994.
- [6] Iqbal.K, R. Abdul Salam, M. A. Osman, and A. Z. Talib. Underwater image enhancement using an integrated colour model. *IAENG International Journal of Computer Science*, vol. 32, no. 2, pp. 239–244, 2007.
- [7] Ren.S, K. He, R. Girshick and J. Sun, Faster R-CNN: Towards Real-Time Object Detection with Region Proposal Networks, *IEEE Transactions on Pattern Analysis and Machine Intelligence*, vol. 39, no. 6, pp. 1137-1149, 1 June 2017.
- [8] A. Horé and D. Ziou, Image Quality Metrics: PSNR vs. SSIM, 2010 20th International Conference on Pattern Recognition, Istanbul, Turkey, pp. 2366-2369,2010.
- [9] A. Mittal, A. K. Moorthy and A. C. Bovik. No-Reference Image Quality Assessment in the Spatial Domain. in *IEEE Transactions on Image Processing*, vol. 21, no. 12, pp. 4695-4708, Dec. 2012.
- [10] A. Mittal, R. Soundararajan and A. C. Bovik. Making a Completely Blind, Image Quality Analyzer. in *IEEE Signal Processing Letters*, vol. 20, no. 3, pp. 209-212, March 2013.
- [11] Y. Wang, W. Song, G. Fortino, L. Qi, W. Zhang and A. Liotta. An Experimental-Based Review of Image Enhancement and Image Restoration Methods for Underwater Imaging. in *IEEE Access*, vol. 7, pp. 140233-140251,2019.
- [12] Xiu Li, Min Shang, H. Qin and Liansheng Chen. Fast accurate fish detection and recognition of underwater images with Fast R-CNN. *OCEANS 2015 - MTS/IEEE Washington*, Washington, DC, USA, pp. 1-5, 2015.
- [13] Nanagasabapathy.K et.al. Validation system using smartphone luminescence. *IEEE International Conference on Intelligent Computing, Instrumentation and Control Technologies (ICICT)*, Pages: 235 – 239, 6-7 July 2017, Kannur, India
- [14] Ambeth Kumar.V.D, et.al. Cloud enabled media streaming using Amazon Web Services. *IEEE International Conference on Smart Technologies and Management for Computing, Communication, Controls, Energy and Materials (ICSTM)*, Pages: 195 – 198, 2-4 Aug. 2017, Vel Tech University, Chennai, India (DOI: 10.1109/icstm.2017.8089150)
- [15] K. Sabarinathan et.al ., “ Machine Maintenance Using Augmented Reality”, 3rd International Conference on Communication and Electronics Systems (ICCES), 2018. (DOI: 10.1109/CESYS.2018.8723900)

# The Solution for XML External Entity Vulnerability in Web Application Security

Prabhakar.M<sup>a,1</sup> and Abdul Raheem Syed<sup>b</sup>

<sup>a</sup>Associate Professor, School of CSE, REVA University, Bangalore, India

<sup>b</sup>Associate Consultant, Capgemini Technologies India, Pvt. Ltd, Bangalore, India

**Abstract.** Web application security the basic requirement and follow as a minimum security standard nowadays to develop online applications. Most of the web applications are managing online transaction like transferring money, pay bills online and many more services related to finance. So, all the web transactions are exchanged of static data related to both the bank parties which is used to populate XML document. And the SOAP web services and REST protocol are used for exchange of two heterogeneous applications and the data is parsed by XML parser. XML External Entity attack occurs as XML input weakly parsed data. This attack refers problems like confidential information, denial of service and server side request information. In this paper we explain about XML External Entities, prevention measures, problems and expected solutions.

**Keywords.** Web Application Security, XML External Entity, Sensitive data exposure, Secure Data Protection

## 1. Introduction

Web Application Security is the latest trend nowadays. Because today all the services are online means the services access any time and any ware. The clients or users are access the application on their convenient time instead of specific office hours also no need to contact with the staff of the office. So, that every client decides instantly as the client's mood change. Once he decides will pay the money also instantly with this online and payment services. Even every application related queries and questionnaire also available online. This services pay the fee with one of the banking services. Here the user may use one of the banking service like Net Banking, Debit Card, Credit Card and also other baking service like PayTm, PhonePe and GooglePay services and many more. From this there may be exchange of information between either two homogeneous or heterogeneous services like Net banking of two same banks or different banks, PayTm to PhonePe or GooglePay so on. The exchange of information between two banking services using any of the web services. The final outcome is communicating with both banking static data and that is very sensitive and critical information. This data is personal data of the bank which need to maintain very secure. Every bank online applications are using different technology for developing their own banking services. The common data for sharing with other bank applications is mostly

---

<sup>1</sup>Prabhakar. M, Associate Professor, School of CSE , REVA University Bangalore, India;  
E-mail: prabhakarm@gmail.com.

in the form of XML format for the exchanging of information with any heterogeneous application. Cyber threats and vulnerabilities risk is explains about different security threats that are vulnerable related to risk of online applications. The over all threat types are as per the OWASP top 10 standards as of 2017 follows below

1. **SQL Injection:** Injection vulnerability are like Structure Query Language (SQL), NoSQL, Operating System and LDAP happens on vulnerable data passed to by the hacker as small portion of code in the executed query. The attacker added data in the query may change the query output for retrieving the data form the table without valid authorization of database. That the query executes with attackers requested data with all the attributes of the table like account details with password information. Based on this information the attacker steal the user sensitive information of the account.

2. **Broken Authentication:** This vulnerability are frequently happens due to no proper coding standards. The attackers are passes the vulnerable data and stealing the password of the user accounts. Passwords are compromised for login the user account by attackers using vulnerable data on the application.

3. **Sensitive data Exposure:** Most of the web applications and related API's are not securing the user and organization private data for example banking sector sensitive data, payment card information, hospital sensitive records and social media application data. The attackers may take the sensitive data also try to modify the sensitive data, data may misuse with wrong data which update, financial information may change from one to another also that information lead to legal problems as it exposure as non secure. Sensitive information might be managed without addition security for example encryption remaining data or transferred information and requires mandatory measures when transmission between the application and program.

4. **XML External Entity (XXE):** legacy or previous version XML versions calculated and managed external entities inside the XML documents. The XML External entities may be utilized for expose sensitive data inside the XML with respect to URI handler, inside records uses, scanning of inside port executing the code remotely and Denial of Service attacks.

5. **Broken Access Controls:** This is similar as the authorized users can access the sensitive data of the users or organizations personal information. Attackers are use their vulnerable code for accessing the unauthorized information like clients personal information, accounts of clients, see and update the sensitive data and also change the password with access controls rights.

6. **Security Misconfiguration:** One of the most normal vulnerable issue is Security misconfiguration. Security Misconfiguration is happening basically because of default setting which are applied, fully configured settings are not completed properly, default user and password updating, frequent basic data giving at the time of configurations. On all the cases of installation and framework settings default and weak information uses for configurations lead to Security Misconfiguration.

7. **Cross-Site Scripting XSS:** XSS vulnerability happening if application contains non-validated data in the latest web page without validation check are not proper. Updates with new patches on old web pages contains user provided information using API that forms new HTML or scripting file. Using cross-site scripting the hackers are accessing the browser session of the user, websites of military services or forwarding the existing session of the applications to do unauthorized transactions like finance and social media accounts information.



8. Insecure De-serialization: This security risk major problem is to execute the code remotely. That to de-serialization flaws do not lead to remote code execution, happen attacks on basic level, SQL Injection vulnerability and authorization related problems.
9. Using Component with known vulnerabilities: Using this vulnerability the basic parts like API's, Frameworks and related modules. Execute with similar authorization privileges in the application without proper validations. Deployed component weak that leads to severe data loss or miss transaction like banking and finance or any sensitive data exposure. As part of weak component and API's lead to severe attack happening.
10. Insufficient Logging and Monitoring: Because of not maintained standards also no secure coding, the log information which is sensitive displayed at the time of execution, user critical data like user-id and password logged and displayed after execution in to the log file that lead to leakage of sensitive data to bout. The storage of information on log files and monitoring the sensitive data in any encrypted format is mandatory. Many types of attacks are happening due to the improper logging of sensitive data that displayed in to the log files [5]. In this paper, we describe, detecting, prevention and solution mechanism of the XML External Entity vulnerability and different types of attacks to access sensitive data using XML parser and weak XML elements definition. Stealing and manipulating data at the time of exchanging of two same or heterogeneous banking or financial applications. Due to this the sensitive data of applications are vulnerable because of weak XML parser. The XML External Entity is the one of the vulnerability risks from the OWASP top ten [12-15].

## 2. XML External Entity (XXE) Processing

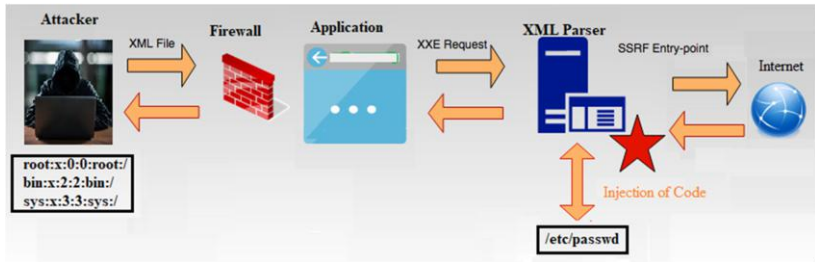
A XXE is one kind of attack instead of specific web application which parses XML input. XXE happens if the input of the XML having the related for the external entities are handled by loosely and not strong arranged XML parser. This type of attack which result opened sensitive information, DoS, SSRF, scanning of the port through the point of view with automated where the parser is found also related framework affects. This type of attack mapped record added the use of external DTDs, the external stylesheet, external schema, so on allow on same.

### 2.1. XML External Entity Attacks

XML External Entity attacks are also called as XXE Injection is a kind of attack that misuse broadly accessible however frequently utilized characteristics of XML parser. Utilization of XML External Entity attacks, an attacker can harm Denial of Service (DoS) just similar usages nearby, remote substance and services. XML External Entity can be utilized to carry out Server Side Request Forgery (SSRF) get the web application to build requests to the different applications. In few situations, XML External Entity attacks that empower port examining and guide for remote code execution. In-band and out-of-band (OOB-XXE) are the two types of XML External Entity attacks. XML (Extensible Markup Language) is a one of the top and common natural data format for accessing any application. XML is utilized from the XML-RPC, SOAP, REST web services via the XML, HTML and DOCX to image files like SVG, EXIF data. To clarify XML information format, the application required an XML parser.

## 2.2. XML External Entity Attack process

The attacker has the chance of XXE attack for getting the vulnerability from the outside code injection of attack. Based on the XXE attack, the “SYSTEM” recognize to get the inside information on a framework locating application of the XML parser of PHP. Mainly the XXE attack are the because of XML parser and the internet firewall of the application.



**Figure 1.** XML External Attack flow

As per the application not required to explicitly responded and gave the result in the attacker related to the doubtful data insecure and viewing without having any encryption or security mechanism. The same attacker can know the Domain Name Service data to break information via sub-domain address to Domain Name Service server which may control by him.

## 2.3. XML External Entity Risk Factors

XML document parsed by the specified web Application. The executed data is permits inside application code region related to the entity of XML, inside portion of DTD. The DTD is processed and validated by the configured XML processor and also sort out the inside the DTD. The many web sites and blogs are explains similar sample code and expected solutions related to risk factors of XXE.

## 2.4. Missing XML Validation

The attacker is getting a chance of passing the malicious data as input because of XML parsing validation failure. The attackers understand the weakness of developer’s non-standard insecure code implementation of the application. With the tolerating XML report non validating is the problem instead of Schema or DTD, the developer less knowledge on XML development, is the chance of attacker to pass the malicious, suspicious, malfunction information. This is not feasible for an XML parser to approve data, that means the parser is not suitable for complete syntactic of information. Any how the parser can do the total and intensive activity of validating the archive information and assurance to the code that forms the record that the information is very much shaped [6].

### 3. XML External Entity (XXE) Prevention Cheat Sheet

Prevention mechanism of XXE attacks allow a malicious person read the protected record data from the server. The server allows for view the sensitive data form the files in the server first level. Because of not implementing any intrusion detection mechanism and much proper prevention of XXE attacks. Protecting the XML External entities from the attackers based on the language and technology related are as follows Disable the parsing of inline DTD, remove the permissions of the web server which the sensitive data is placed and processed for execution of the user or organization request [9]. Some of the sample code based on the technology and language are in the Python use the defused.xml library for XML parsing. Ruby – you can disable expanding of XXE in Nokogiri as updated in many technical blogs and free code reference websites. XXE injection is one out from OWASP top 10 vulnerability that the attacker passes the malicious input data which is executed by the weak XML parser in the application. This is happening because of the XML elements not in format having related through the external entity executed via the no properly configured XML parser. There are many ways for preventing the XML External Entity attack mainly try to disable entire External Entity of DTD [8]. Based on the parser below method is related for all `factory.setFeature("http://apache.org/xml/features/disallow-doctype-decl", true)`; Denial Of Service attack secure if we disable DTD parser and external entities must disable on every specified parser.

### 4. Conclusion and Future Work

In this paper, explains about XML External Entities attacks which may lead to the loss of web application and the organization. The attackers are incorporate uncovered inside data records, that includes private and protected information for example, password, sensitive client information. Some situations XML parser library which is vulnerable to on browser header passed for client-side information. In banking and related organization are exchange of private and sensitive data related to organization using web services. XML External Entity attack, hacker view and modify the XML data inside the web browser which are related to sensitive and private. After the attacker either use the with same credentials or malfunction with malicious data. Most of the attacks are happens with external injection of malicious code or weak of XML Parser, weaker DTD external entities. This paper we explain about major problems of the XXE attack, prevention mechanism and some of the expected solutions to avoid. This is happening mainly because of setting up default configuration done by the developer. The developer required to change the default configuration with valid data and strong parser configuration. And prevention mechanisms of different technologies like Java, PHP, C++ and C#. Future, we will discuss few more XML External Entity detection and prevention mechanisms and security measures at the time of web application development.

### References

- [1] XML External Entity (XXE) Processing. (2015). Retrieved December 12, 2015, from [owasp.org: https://www.owasp.org/index.php/XML\\_External\\_Entity\\_\(XXE\)\\_Processing](https://www.owasp.org/index.php/XML_External_Entity_(XXE)_Processing)

- [2] Facebook Bug Bounty. (2014). Retrieved December 12, 2015, from facebook.com: <https://www.facebook.com/BugBounty/posts/778897822124446>.
- [3] Almroth, Fredrik Nordberg and Karlsson, Mathias. (2014). How we got read access on Google's production servers. Retrieved December 12, 2015 from detectify.com: <http://blog.detectify.com/post/82370846588/how-we-got-read-access-on-googlesproduction>
- [4] Rachel Hogue A Guide to XML External Entity Processing, in Tufts University Comp 116: Introduction to Computer Security Mentor: Ming Chow Fall 2015.
- [5] Project Chapters events about OWASP top 10 <https://owasp.org/www-project-top-ten/>.
- [6] Morgan, Timothy D. and Ibrahim, Omar Al. XML Schema, DTD, and Entity Attacks. A Compendium of Known Techniques. (2014). Retrieved December 12, 2015, from vsecurity.com: <http://www.vsecurity.com/download/papers/XMLDTDEntityAttacks.pdf>
- [7] Stuttard, Dafydd. Burp Suite now reports blind XXE injection. (2015). Retrieved December 12, 2015, from portswigger.net: <http://blog.portswigger.net/2015/05/burp-suite-now-reports-blind-xxe.html>.
- [8] Prevention of XML External Entities using Cheat Sheet from OWASP top 10 [https://owasp.org/www-project-cheat-sheets/cheatsheets/XML\\_External\\_Entity\\_Prevention\\_Cheat\\_Sheet.html](https://owasp.org/www-project-cheat-sheets/cheatsheets/XML_External_Entity_Prevention_Cheat_Sheet.html).
- [9] Prevention of XML External Entities <https://www.hackspaining.com/prevention/xml-external-entities>
- [10] Mitigate XXE vulnerabilities in Python <https://www.acunetix.com/blog/web-security-zone/how-to-mitigate-xxe-vulnerabilities-in-python/>.
- [11] Mitigate XXE vulnerabilities in Out-of-band XML External Entity <https://www.acunetix.com/blog/articles/band-xml-external-entity-oob-xxe/>.
- [12] Nanagasabapathy.K et.al. Validation system using smartphone luminescence. IEEE International Conference on Intelligent Computing, Instrumentation and Control Technologies (ICICICT), Pages: 235 – 239, 6-7 July 2017, Kannur, India
- [13] Ambeth Kumar.V.D et.al.Cloud enabled media streaming using Amazon Web Services. IEEE International Conference on Smart Technologies and Management for Computing, Communication, Controls, Energy and Materials (ICSTM), Pages: 195 – 198, 2-4 Aug. 2017, Vel Tech University, Chennai, India (DOI: 10.1109/icstm.2017.8089150)
- [14] Aravindh.B et.al. A novel graphical authentication system for secure banking systems. IEEE International Conference on Smart Technologies and Management for Computing, Communication, Controls, Energy and Materials (ICSTM), Pages: 177 – 183, 2-4 Aug. 2017, Vel Tech University, Chennai, India
- [15] Ambeth Kumar.V.D et.al, (2016).An Efficient Security System for Data base Management from Illegal Access.IEEE International Conference on Wireless Communications, Signal Processing and Networking (WiSPNET), SSN Engineering College, Chennai, India, 23-25 March, 2016
- [16] 25.K. Sabarinathan et.al ., “ Machine Maintenance Using Augmented Reality”, 3rd International Conference on Communication and Electronics Systems (ICCES), 2018. (DOI: 10.1109/CESYS.2018.8723900)

# An Analysis on Monitoring of Healthcare by Means of Internet of Things

Sathish N<sup>a,1</sup>, Valarmathi K<sup>b</sup>, Elangovan G<sup>c</sup>

<sup>a</sup>Assistant Professor, Dept of CSE, Panimalar Engineering College Chennai, India

<sup>b</sup>Professor, Dept of CSE, Panimalar Engineering College, Chennai, India

<sup>c</sup>Associate Professor, Dept of CSE, Panimalar Institute of Technology, Chennai, India

**Abstract.** The convergence of computer science and electronics domain has resulted in the Internet of Things, which is perhaps the most striking innovative outcome (IOT). The Internet of Things (IoT) is a innovative technology with the aim of rapid evolution by means of numerous new advancements in clinical and wellness areas. Over the last few years, the impact of IOT in medical services has significantly increased. Internet of Things (IoT) based Health-related wearable devices are posing new challenges by incorporating creative innovation and assets. In/out understanding's wellbeing status can be observed intermittently and routinely using wellness wearable gadgets. The Internet of Things (IoT) will profoundly help patient investigation and testing methods due to tiny internet protocol based sensors in a remote location that can be mounted on the patient's body. Currently there are devices with seven billion in value, with expertise predicting the number will rise to ten billion by 2020 and 22 hundred million by 2025. This paper aims to examine and comprehend the utilization of Internet of Things in redesigned healthcare services, as well as how outstanding medical care can be obtained with ease. To summarise, the discussion has been projected on IoT capabilities on remote and detection frameworks and on the relevances utilized on effective medical care applications.

**Keywords.** Internet of Things, Healthcare Monitoring, medical devices, Artificial Intelligence, Machine Learning.

## 1. Introduction

Mostly with advent of technology, the environment has become more portable, and people no longer only interact with one another, but also with objects. The Internet of Things has made it possible to link anything. The Internet of Things binds billions of computers. As a result, this concept simplifies human life. Since the stone age, one of the most important problems that humans have had to contend with is their welfare. Health conditions are more handled and monitored now than they have been in modern memory, thanks to technological advancements. Despite the fact that certain major medical care problems remain unknown, we have come a long way from where we started. Then again, specialists can oversee and counsel patients without any problem. Over these years a few progressed IOT applications has been created to help patients

---

<sup>1</sup>Sathish N, Assistant Professor, Dept of CSE, Panimalar Engineering College, Chennai, India. Email:nsathishme@gmail.com<sup>1</sup>

and clinical officials. IOT causes medical care to improve existing highlights by supporting patient administration, clinical records the board , health related crisis the executives, Treatment the executives and different offices , in this way expanding the nature of medical services applications. Medical clinics use IOT to screen patients constantly and to give ongoing medical care offices. [2,3,4,5,6,7]Internet of things can possibly follow individuals, administrations and item precisely. In this way, examining those information give the exact outcomes. In clinical field exact data lead into the best come about medicines. With IOT specialists can gauge indispensable signs and other bio-metric data of patients with the appended sensors to patients. In this way, the sicknesses and issues could be analyzed rapidly. With the assistance of IOT clinics and rescue vehicle administrations can rapidly get advised when individuals need their administrations in addition with IOT streets and traffic signals can be controlled to help ambulances to arrive at clinic rapidly. [3]. Figure 1 shows the applications ofIoT.



Figure 1.IoT and its applications

## 2. Healthcare Environment Based On Iot

IoT accepts crucial situations within various applications related to medical services. Groupings with respect to customized medical services IoT frameworks are clinical consideration, remote checking, and framework responsiveness. In clinical consideration, patients who are hospitalized especially within basic circumstances, necessitate steady and secure thought to respond somewhat conceivable on to some crisis cases[10][11], which may expand saving the life time of patients. Because of sensors utilized based on IP , the fundamental data concerning wellbeing of patients be able to distantly gathered and shipped off parental figures utilizing the web for additional consideration and examination. This will keep the parental figure from visiting every tolerant checking of status, consequently saves time throughout different mediations [12]. Various wellbeing experts can cooperate to monitor various characteristics of patients, each utilizing based on personage qualities, and examining their movement abiding the data assembled with respect to sensors. Thus, getting affirmation that a patient is in a crisis condition will transform into a straightforward undertaking[13].In remote checking, some more seasoned and more youthful patients, just as persistently debilitated patients, ought to be examined consistently. Distant observing will assist thesepatients with trying not to make outings to the wellbeing community to be checked. Considering their basic status, a few changes in their prosperity will go unseen until a disease arrives at the place of crisis. In framework responsiveness, the opinion of patient's condition is perceived [14] with their

environmental factors that altogether helps medical services experts to combine all affecting varieties that impact the wellbeing of individual patients. Also, the distinction in the state of being of a patient may broaden the level of its weakness to infection and be an explanation behind their diminishing in prosperity [16].The Table 1 depicts the various utilization of IoT in Healthcare environment[15].

**Table 1.** Healthcare Variants Analysis

<b>Author</b>	<b>Description of the Literature</b>
Chao Lia et al 2017[6]	<ul style="list-style-type: none"> <li>• With unavoidable observing framework actual indications of patients are shipped off far off clinical application progressively.</li> </ul>
Shruti Gotadki et al 2014[1]	<ul style="list-style-type: none"> <li>• Getting patients to emergency clinic at the ideal time isn't simple on account of the gridlocks in the urban areas and cooperations.</li> </ul>
Lei Yu et al. 2012[2]	<ul style="list-style-type: none"> <li>• The proposed framework has capacity to carry out data trade, savvy acknowledgment. Situating, following, observing. This framework has a few key advances.</li> </ul>
Deepika Mathuvanthi et al 2019[7]	<ul style="list-style-type: none"> <li>• The research is planned to distinguish surprising perspectives and personality of the patients who has despondency, nervousness or stress. .</li> </ul>
Haleem et al 2019[5]	<ul style="list-style-type: none"> <li>• Researchers have proposed strategies how IOT can help muscular health patients to improve the nature of medicines. sensors give the estimation of bone and crack data rapidly.</li> </ul>
Diaasalama et al 2018[4]	<ul style="list-style-type: none"> <li>• This research work proposed a medical care answer for patients and their guardians to determine this issue with a savvy pill box with cutting edge highlights.</li> </ul>
Abo-Zahhad et al 2014[3]	<ul style="list-style-type: none"> <li>• Researchers have proposed a framework to give Expert based medical care to understaffed distant locales through IOT called telemedicine.</li> </ul>

- Ashlesha et al. 2017[8]
  - There are a few issues found in IoT and existing wellbeing checking. New innovations could assist with limiting them by accomplishing the better quality just as electronic security idea.
  
- VaniYeri et al. 2020[9]
  - The proposed framework is carried out for remote wellbeing observing of the patients.

### 3. Relevances Of Iot In Healthcare

Medical care devices that are essential for an informative environment provide modern quality by automating procedures, facilitating collaboration, and securely managing data. Smart platforms provide clinicians with easy access to patient records, minimise costs, and boost productivity improvements, all of which lead to a better clinical care [18]. Several examples are provided here. Any patient's biometrics are tested separately by setting patient-explicit limit settings in scalable and continuous pulse observing. A patient's ECG pulse (HR) (counting HR inconstancy and HR unwavering quality), breath rate, action level, and body position can all be screened using such a system. Additional instruments can be used in order to remotely track vital signs such as circulatory strain and weight. A cadence testing system can be used in conjunction with beat observing to better comprehend the cardiovascular component of unexplained manifestations. Other clinical uses of such a framework incorporate arrhythmia drug treatment to screen treatment viability, postablation systems to screen cardiovascular musicality, and the checking of vitals, for example the distant checking of heart mood breath and movement [19].

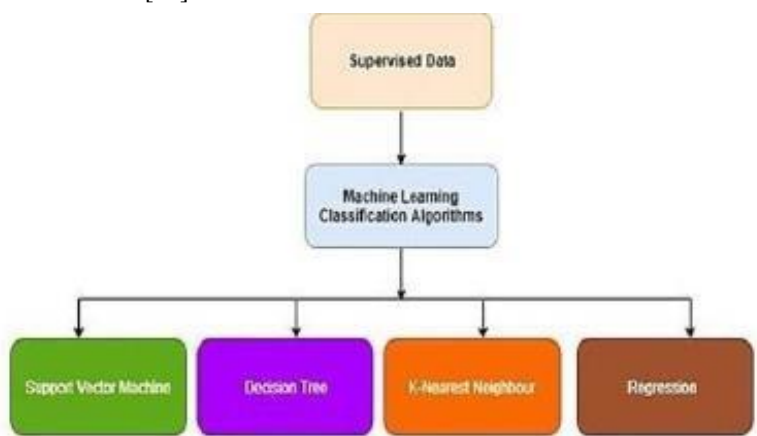


Figure 2. Classifications of Machine Learning Algorithms

In future work, the above examples can be implemented using machine learning algorithms which is depicted in Figure 2.



## 4. Conclusion

The present discussion emphasized on various dissemination modes related to Healthcare monitoring using Internet of Things. We have also discussed on the value of the Internet of Things in the healthcare sector, which is a study of healthcare and protection. It has clarified the IoT's utilization in the sector related to healthcare and confirmed about the much intrinsic IoT transition in environment based on healthcare is presently instantaneous in coordination with efficient machine learning algorithms in future.

## References

- [1] ShrutiGotadki, Radhika Mohan, MazharAttarwala , Prof. M.P. Gajare 2014, Intelligent Ambulance, International Journal of Engineering and Technical Research. Volume-2, Issue-4, pp 49-51.
- [2] Lei Yu, Yang Lu, XiaoJuan Zhu 2012 . Smart Hospital based on Internet of Things. Journal Of Networks, vol. 7, NO. 10, pp1654-1651
- [3] M. Abo-Zahhad, Sabah M. Ahmed, and O. Elnahas 2014. A Wireless Emergency Telemedicine System for Patients Monitoring and Diagnosis. International Journal of Telemedicine and Applications, <https://doi.org/10.1155/2014/380787>
- [4] DaaSalama Abdul Minaam, MohamedAbd-ELfattah 2018, Smart drugs:Improving healthcare using Smart Pill Box for Medicine Reminder and Monitoring System, Future Computing and Informatics Journal ,Volume 3, Issue 2, December 2018, Pages443-456.
- [5] Haleem A, Javaid M, Khan IH 2019, Internet of things (IoT) applications in orthopaedics, Journal of Clinical Orthopaedics and Trauma doi: <https://doi.org/10.1016/j.jcot.2019.07.003>.
- [6] Chao Lia, Xiangpei Hu , Lili Zhang 2017 ,The IoT-based heart disease monitoring system for pervasive healthcare service, Procedia Computer Science ,Vol 112 pp2328–2334.
- [7] DeepikaMathuvanthi P, V. Suresh, Ch. Pradeep 2019, IoT Powered Wearable to Assist Individuals Facing Depression Symptoms, International Research Journal of Engineering and Technology, Vol 6, pp:1676-1681.
- [8] Ashlesha A. Patil, S. R. Suralkar 2017, Review on-IoT Based Smart Healthcare System, International Journal of Advanced Research in Engineering and Technology, Volume 8, Issue 3, pp. 37–42.
- [9] VaniYeri, Shubhangi D C 2020, IoT based Real Time Health Monitoring, Proceedings of the Second International Conference on Inventive Research in Computing Applications (ICIRCA-2020), pp980-984.
- [10] Why is IoT important? <https://www.oracle.com/internet-of-things/whatis- iot.html> acceded on 1/1/2020 Accessed date1/1/2020.
- [11] S.M. Thaug, H.M. Tun, K.K. Win, M.M Than, Exploratory Data Analysis Based on Remote Health Care Monitoring System by Using IoT, Communications, vol. 8, issue 1, pp. 1–8, 2020.
- [12] J.B Arora, S. Kaushik, IoT in Education: A Future of Sustainable Learning, in Handbook of Research on the Internet of Things Applications in Robotics and Automation, IGI Global, pp. 300–317, 2020.
- [13] R. Rajaseskaran, R. Jain, M. Sruthi, Patient Health Monitoring System and Detection of Atrial Fibrillation, Fall, and Air Pollutants Using IoT Technologies, in Incorporating the Internet of Things in Healthcare Applications and Wearable Devices, IGI Global, pp. 165–183, 2020.
- [14] G.S. Fischer, R.D.R. Righi, V.F. Rodrigues, C.A. da Costa, Use of Internet of Things with Data Prediction on Healthcare Environments: A Survey, International Journal of E-Health and Medical Communications (IJEHMC), vol 11, issue 2, pp. 1–9, Apr2020..
- [15] A Survey on Internet of Things and Cloud Computing for Healthcare <https://www.mdpi.com/2079-9292/8/7/768/htm>. Accessed date1/1/2020
- [16] Agarwal, Technologies in Health Care Domain: A Systematic Review, International Journal of e-Collaboration (IJeC), vol. 16, issue 1, pp. 33–44, Jan2020.
- [17] K. Sabarinathan et.al ., “ Machine Maintenance Using Augmented Reality”, 3rd International Conference on Communication and Electronics Systems (ICCES), 2018. (DOI: 10.1109/CESYS.2018.8723900)

# A Robotic Assisted System Using Deep Learning for Navigation and Reading IoT Based Home Automation for Visually Impaired

Jayashree S<sup>a,1</sup>, Jaswanthi R<sup>b</sup>, Harshitha S V<sup>c</sup>

<sup>a,b</sup>UG Scholar, Dept of ECE, Panimalar Engineering College, Chennai, India

<sup>c</sup>Associate Professor, Dept of ECE, Panimalar Engineering College, Chennai, India

**Abstract.** This paper presents a personal guidance system to help the visually impaired people to face the world independently; this is achieved by transferring visual world into the audio world by alerting them with a voice message. Navigation assistance is included with object detection, so object interference in the path of navigation the vision deprived person is alerted about the object in the path. The system is also implemented with an IOT based load control to help them with household objects; the load control can be operated with the help of Blynk Application which is made enable with voice assistant. In this project we have used an algorithm, real time object detection using deep learning. This model is trained with more images to recognize an object. OCR is implemented for the reading assistance module in this system.

**Keywords.** Assistive technology, blind people navigation, visually impaired, reading assistant, deep learning Raspberry pi 3processor

## 1. Introduction

The ability of a human to see is one of the fundamental needs. Eyesight is a quintessential requisite as it gives us a perception of the world around us. Life hits hard on the visionless people. Globally more than 2 billion people are suffering from vision impairment. The people with destitute of vision have a hard time in day-to-day life even with simple chores. In case of older adults' vision impairment can be a higher risk of falls and fractures. The visual world has to be transformed to an audio world for them. The major challenge blind person faces is navigation and reading text. The majorly used aids for visually impaired people are guide dogs and white cane. This proposed system reduces dependency of other people to the blind person and give major support in indoor navigation. This system aspires to assist visually impaired in reading by providing audio information of the textual verses.

---

<sup>1</sup>Jayashree S, UG Scholar, Dept of ECE, Panimalar Engineering College, Chennai, India, E-mail: jayashrees22@gmail.com

This proposed system has a Raspberry Pi-3 processor which uses deep neural network for image processing. Web camera is the input device utilized which is connected to the processor. A real time image is captured by the web camera and is sent to the Raspberry Pi-3 processor for further processing.

## 2. Related work

M. H. Mahmud, R. Saha and S. Islam,[6] has proposed a Smart Walking Stick[6], which uses a group of sensors positioned at approximate places to detect the object and indicated with An Light Emitting Diode indicator. The entire walking stick is controlled by a PIC microcontroller [6]. A. Mocanu, V. Sita, C. Avram, D. Radu and A. Aștilean, [1] has proposed a walking cane with Assistive Navigation Application for Blind People using Embedded System. This paper proposes a system which by all means is competent to provide assistance to the visually impaired to navigate independently [1]. O. Gamal, S. Thakkar and H. Roth, [2] has proposed an Intelligent Assistive System for Visually Impaired People for Outdoor Navigation [2]. In the present paper, we propose a compact device consisting of text to speech converter along with outdoor navigation system and home automation. It thereby strongly helps the visually impaired and empowers them.

## 3. Proposed work

### *a. Text to speech conversion*

In this proposed work we have used Optical Character Recognition (OCR) algorithm and Google text to speech technique. Optical Character Recognition is a procedure that devises the operation of electronically reconstructing the graphic text images and handwritten entries in order to detect the underlying text by converting it into encoded data which within realm of possibility interpreted by a computer. The process is deployed by initially scanning the image which encompasses textual verses and scrutinizing of the image in order to single out the characters. Consequently, upon recognition the character is transformed to encoded text. Initially the scanned image consisting of text and graphic elements is remodelled into a bitmap (matrix of black and white). Further it is pre-processed so as to adjust the brightness and contrast thereby boosting the accuracy of the process. The image is now classified into various zones based on the areas of importance i.e., where the textual data exists, to launch the extraction procedure. Finally, the zone containing text and be further be divided into lines and thereby into characters. The obtained characters are now used by software to match by using various comparison and detection algorithms. The OCR engine deployed here is Tesseract which incorporates various wrappers. Pytesseract is the wrapper used. Pre- processing is the vital stage of the procedure. The obtained characters further go through text to speech (TTS) conversion. GTTS (Google-text-to-speech) is a python library which is deployed for the conversion which can further be saved as audio files. It also supports assorted languages which act as a convenience to people of various ethnicities.

### *b. Autonomous Navigation and Object Detection*

The target of the object detection and navigation system is to distinguish various instances of objects from a given dataset and help the user navigate to provided destination accordingly based on the obstacle. Indifferently, a small class of objects are detected in the image, but a large number of desirable locations exist and the scales at which the expected outcome occurs, and is to be discovered. Each time an object is detected it is proclaimed with a structure of information. This information could be as basic as the placement of an object, a particular location and scale, or the object characterization in accord to the bounding box. In other scenarios, this information is more descriptive and houses the parameters of a linear or non-linear transformation. In the following proposed system, the background subtraction can be used by demonstrating the fixed web camera and producing a foreground mask. It compares the frame with the normal one containing background images or models which comprises the static area of the current scenario. The remaining area is compiled as the background part of images per se.

The background subtractions are consummated using the raspberry pi camera. The Image is captured by the web camera which is set-up on the raspberry pi module. The image is extracted from the camera and is sent to the raspberry pi module followed by the execution of the python code. In the code, the generated signals originate from the deployment of the module and further sent to the navigator. By the amalgamation of sensors and raspberry pi module, the object can be detected. Based on the object detection the navigator directs itself towards the required destination

### *c. Home Automation*

Home automation is not an envisioned idea but is already persisting right from 2000's. In our project we have used Blynk application which is an advanced platform that grants you to promptly build an interface with a view to regulate and monitor an extensive range of hardware components from our gadgets without sophisticated code. Blynk application comprises of a unique identifier designated to individual user. On initiating the internet connection to the device i.e., the Raspberry Pi, the Blynk application functioning on the gadget establishes the connection to its server engaging the unique identifier established earlier. The server then indicates the application on the gadget, and then establishes the connection [13].

In order to execute the basal procedures (like turning GPIO pin – off or on) there is no necessity to do any coding. On the other hand, transmitting the information from the Pi back to the device requires a considerate amount of code [13]. To make it voice controlled we have enabled Google assistant to the Blynk app via IFTTT which act as an intermediate between the two application.

#### 4. Block diagram

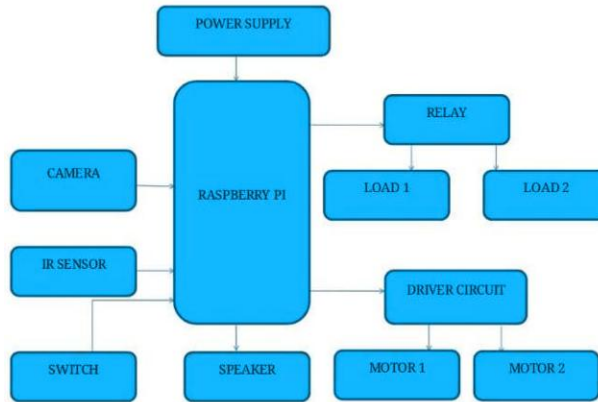


Figure 1. Diagram of proposed work

#### 5. Result and discussion

Thus, the project we proposed tends to provide with a complete guidance to the visually deprived people. It may also be used as a helping aid robot for the elderly. In this system proposed here we used predefined or pre-stored path for indoor navigation, further GPS module can be established for outdoor navigation. The accuracy of the Reading assistant can be improved at a greater extent using higher end camera with higher resolution and by including high memory processor, graphics card like NVIDIA which can even be developed to recognize more sophisticated scripts, cursive, handwriting texts etc.

#### 6. Conclusion

The above proposed system is a simple architecture that transfigures text which is captured using a camera to audio data using Raspberry Pi module. It doesn't need any required skill or specific knowledge to operate it thus it reduces dependency to the blind. The navigation module assists the visually deprived in their way finding. It is also assisted with IOT based load control helps in ease of operating loads.

#### References

- [1] Mocanu, V. Sita, C. Avram, D. Radu and A. Aștilean, Assistive Navigation Application for Blind People using a White Cane Embedded System, 2020 IEEE International Conference on Automation, Quality and Testing, Robotics (AQTR), Cluj- Napoca, Romania, 2020, pp.15,doi:10.1109/AQTR49680.2020.9129942.
- [2] Gamal,S.ThakkarandH.Roth,TowardsIntelligentAssistiveSystemforVisuallyImpairedPeople:OutdoorNavigatinSystem,202024thInternationalConferenceonSystemTheory,ControlandComputing(IC

- STCC), Sinaia, Romania, 2020, pp.390-397, doi:10.1109/ICSTCC50638.2020.9259682.
- [3] Bourne, S.R. Flaxman, T. Braithwaite, M.V. Cicinelli, A. Das, J.B. Jonas, J. Keeffe, J.H. Kempen, J. Leasler, H. Limburg, K. Naidoo, K. Pesudovs, S. Resnikoff, A. Silvester, G.A. Stevens, N. Tahhan, T.Y. Wong and H.R. Taylor, Magnitude, temporal trends, and projections of the global prevalence of blindness and distance and near vision impairment a systematic review and meta-analysis, *The Lancet Global Health*, vol.5, no.9, pp. e888 - e897, September 2017.
  - [4] Population Reference Bureau, 2017 World Population Datasheet, August 2017.
  - [5] A. T. Noman, M. A. Mahmud, H. Rashid and S. M. Saifur Rahman, Design and Implementation of Microcontroller Based Assistive Robot for Person with Blind Autism and Visual Impairment, in International Conference of Computer and Information Technology (ICCIIT), Chittagong, Bangladesh, 2017.
  - [6] M.H. Mahmud, R. Saha and S. Islam, Smart Walking Stick An Electronic Approach Assist Visually Disabled Person, *International Journal of Scientific & Engineering Research*, vol.4, no.10, 2013.
  - [7] Borenstein and I. Ulrich, The Guide Cane – A Computerized Travel Aid for the Active Guidance of Blind Pedestrians, in International Conference on Robotics and Automation, Albuquerque, New Mexico, 1997.
  - [8] R.A. Zeineldin and N.A. ElFishawy, Fast and Accurate Ground Plane Detection for the Visually Impaired from 3D Organized Point Clouds, in SAI Computing Conference, London, UK, 2016.
  - [9] A. Kaehler and G. Bradski, *Learning OpenCV3*, Sebastopol, CA: O'Reilly Media, Inc., 2016.
  - [10] J. Busck and H. Heiselberg, High Accuracy 3D Laser Radar, in Society of Photo-Optical Instrumentation Engineers, Florida, USA, 2004.
  - [11] C. Stoll, R. Palluel Germain, V. Fristot, D. Pellerin, D. Alleysson and C. Graff, Navigating from a Depth Image Converted into Sound, *Hindawi*, vol.2015, no.10.1155/2015/543492, p.9, 2015.
  - [12] StereoLabs, How does the ZED work? - Help Center | Stereolabs, [Accessed 8 May 2019].
  - [13] www.bc-robotics.com, - internet source.

# Deep Learning for Multi Grade Brain Tumor Classification in Smart Healthcare Systems: A Prospective Survey

Sravya V J<sup>a,1</sup> Malathi S<sup>b</sup>

<sup>a</sup>PG Scholar, Dept of CSE, Panimalar Engineering College, Chennai, India

<sup>b</sup>Professor, Dept of CSE, Panimalar Engineering College, Chennai, India

**Abstract.** Cancer is one the dangerous disease for human mankind. There are different types of cancers and the dangerous among them is Brain tumor cancer. Though radiologists are able to diagnose the brain tumor, they find difficulties in identifying grade of brain tumor. In the digitally advanced field, the grade identification of brain tumor still seems a challenging task. There are multiple survey that study the identification of brain tumor. But identifying grade of brain tumor is one area which needs more focus. State of the art convolution network is an key algorithm to identify brain tumor grades. We explore convolution network with transfer learning techniques and data augmentation to achieve more accuracy in detecting appropriate grade of brain tumor. We also detail describe various techniques used prior to our study and how our study enhances from current mechanism.

**Keywords**— multi grade, brain tumour, deep learning, health monitoring, image processing, intelligent healthcare

## 1. Introduction

Brain tumor has gained lot of researcher's attention with advancement in technology in the field of medical image processing. Death rate due to brain tumor keeps on increasing year by year, stated by Nation Brain Tumor Foundation. Identifying brain tumor and predicting the type is major challenge. Medical images are examined by experts and for identifying brain tumor. Nature of the image adds up complexity for diagnosing with human eye because accurate detection and precise location of cancer cells are required for critical diagnosis. Expert diagnosis is very much required for accurate segmentation and classification. Complete manual diagnosis is time consuming and also fully automated solutions are yet to be achieved. These automated system demand second opinion as we deal with life. While we mostly depend on expert advice, several studies have proposed automated solution or semi-automated solution based on historical data in the absence of experts. World Health Organization(WHO) has studied different types of brain tumor and provided the classification standards for brain tumor. They have classified the brain tumor from Grade I to Grade IV wherein

---

<sup>1</sup> Sravya.V, PG Scholar, Dept of CSE, Panimalar Engineering College, Chennai, India;  
E-mail:sravya.krupakar@gmail.com

Grade I is considered as benign and Grade IV is considered as highly malign. Glioblastomas, the grade IV is classified as most dangerous type of brain tumour and Histopathology is the most preferred method to identify grade IV tumours from other grades of brain tumour. Different features of grade IV brain tumours are necrosis, vascular thrombosis, vascular proliferation. These features are used to differentiate grade IV brain tumour from others. These features are not transparent and difficult to recognize. The difficulties in identifying these features in native eyes leads to different opinion among pathologists. Histopathological methodology has defects and this results in gliomas unclear. MRI is widely used to overcome the challenges in histopathological methodology. The major advantage here is MRI is able to detect diverse tissues. Also with MRI, varied tissue outline configuration is achieved. Also with appropriate sequence, MRI technology was able to successfully separate low grade tumors from grade IV malignant tumour.

## 2. Related work

We have collected all the research dataset on brain tumour along with their benchmarks. we have focussed on survey of brain tumour classification and its predominant diagnosis techniques, advantages and limitations

1. Deep learning has evolved a lot and found major industry break through in the field of image processing. We analyzed transfer learning techniques from deep learning models for brain tumor with and without augmentation of data. Statistics of these models with various parameters are detailed out in our study.
2. With smart device being turning the table with evolution of the decade, we have focused the study on usage of smart devices and cloud computing. Solutions integrated with these technologies will be the future.
3. Different deep learning methodologies are studied to spot the major challenge in the domain of Brain tumor classification under healthcare. Recommendation and future study of different methodologies were also focused

**Table 1.** Method adopted so far and their accuracy and drawbacks which paved the way for the emergence of new methodology

S: NO	METHODOLOGY	ACCURACY	DRAWBACKS
1.	Noise Removal	95%	They degrade image details and edges of the image. Therefore noised image would be blurred
2.	Image Processing	80%	Image takes gets ruptured as days goes by.
3.	Preprocessing	30%	Have some unwanted distortions or enhances some <b>image</b> features important for further processing.



4.	segmentation	25%	The least method used as they have various error in working.
5.	Feature extraction	67%	Image dets destroyed or get faded.
6.	classification	70%	The disadvantage is that the accuracy depends on the <b>classification</b> accuracy
7.	CNN	87%	lack of GPU in system make CNN training time high for training, if it has more layers
8.	Training	90%	Training majorly depends on quality of data.
9.	Gray scaling	86%	Slicing out to get perfect image leads to data loss.
10.	AlexNet	75%	Possibilities of malfunction on running.
11.	GoogleNet	89%	Google Net proposed architecture promise on better performance
12.	Neural Network	60%	Local minima. Over-fitting
13.	Machine learning	40%	Makes the system more complex.
14.	KNN	30%	Sensitive to noise.
15.	SVM	54%	Testing is slow No desired output is obtained.
16.	MobileNet	70%	It is less accurate than other state-of-the-art networks
17.	Ensemble learning	30%	Does not provide the required result
18.	Probabilistic neural network	15%	Complexity of the system is high.
19.	Decision tree	45%	Unstable classifier. Performance low
20.	Behavior analysis	40%	Not predictable

## 2.1 Methodology

We have used clinical dataset of brain tumor for our project. The dataset contains MRI images of benign and malign brain tumors. The raw images needs to be pre-processed. Later augmentation and segmentation techniques need to be applied on the preprocessed data. Deep Learning techniques will be applied after splitting the data into

training, validation and testing data. CNN algorithm is optimized with appropriate hyperparameter tuning. Majority of the data contains noise in the form of patients data in text format. The RGB data is converted into gray scale by applying weighted average technique. In medical field, images are mostly affected by salt and pepper noise. To suppress the noise by salt and pepper, the effective method of median filter is applied. We apply median filter at very early stage of project lifecycle to remove the noise and improve accuracy. Segmentation is a key area for brain tumor analysis. This effectively extracts the region of brain from the skull. Thresholding methodology is used to get the piece of brain from the skull as part of segmentation. Morphological methods such as dilation and erosion to get the appropriate shape. Since deep learning techniques does not work effectively when data is less, we apply data augmentation technique to increase the size of the data. This also helps to avoid overfitting of data. Deep learning is widely used for classification after major break through. CNN is the mostly used among Deep learning for image processing. Considering the accuracy of CNN, and its usage across image processing, we have used CNN for our multi grade brain tumor classification problem. CNN learns the spatial correlation between pixels better by studying them in hierarchical method. This is achieved with convolving image with feature maps. Later size of the features is reduced with max pooling layer and lately flattened by applying feed to dense layer.

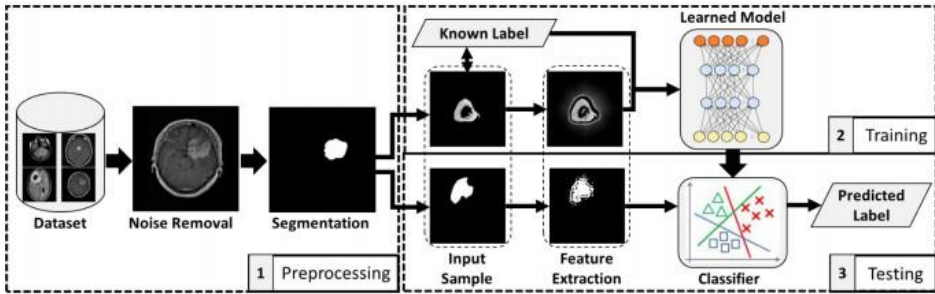


Figure 1. Architectural diagram

### 3. Conclusion and future work

Considering the recent development in the domain of BTC and the limitations of existing studies, we presented a comprehensive survey of deep learning-based BTC methods. Deep learning technologies accurately assist radiologists in predicting the tumor regions and further classifying them into their respective types. Many researchers contributed to the field of BTC, but many challenges remain therein. Therefore, we conducted this study to provide the overall literature of deep learning-based BTC methods in a single survey and to draw the attention of both academia and industry toward the necessary development in this domain. This article comprehensively discussed all deep learning-based BTC methods, with their achievements and weaknesses, followed by complete information about the existing publicly available data sets with their respective resources. In order to empirically inform the conclusions drawn from our literature study, we experimentally analyze various deep learning models by performing extensive experiments over BTC data sets and highlighted the suitable option for consideration in smart health care. Finally, this study highlighted key

challenges, such as lack of public data sets and end-to-end deep learning models, and suggested detailed directions for further research in BTC domain, i.e., exploring edge/fog/cloud computing with FA, advanced data-enrichment techniques, model confidence and explainability, IoMT, and deep investigation of sequential and transfer learning strategies. This can increase the maturity level of BTC methods with better applicability for commercial clinical applications and their smooth integration with smart healthcare. The brain is an intriguing system whose complexity demands sophisticated means to understand and characterize its behavior. The unrivaled learning capability of deep learning models has made them the standard choice to detect and classify brain tumors from MRI images and other monitored data alike, spawning a flurry of research activity overviewed in this survey. We hope that the numerous research paths outlined in our overview will serve as supportive material for the research community currently working on this field and a stimulating read for newcomers to this domain.

## References

- [1] C.-M. Feng, Y. Xu, J.-X. Liu, Y.-L. Gao, and C.-H. Zheng, Supervised discriminative sparse PCA for com-characteristic gene selection and tumor classification on multiview biological data, *IEEE Trans. Neural Netw. Learn. Syst.*, vol. 30, no. 10, pp. 2926–2937, Oct. 2019.
- [2] A. Ruiz-Garcia, N. Webb, V. Palade, M. Eastwood, and M. Elshaw, Deep learning for real time facial expression recognition in social robots, in *Proc. Int. Conf. Neural Inf. Process.*, 2018, pp. 392–402.
- [3] J. Sun, C. Li, X.-J. Wu, V. Palade, and W. Fang, An effective method of weld defect detection and classification based on machine vision, *IEEE Trans. Ind. Informat.*, vol. 15, no. 12, pp. 6322–6333, Dec. 2019.
- [4] M. Mahmud, M. S. Kaiser, A. Hussain, and S. Vassanelli, Applications of deep learning and reinforcement learning to biological data, *IEEE Trans. Neural Netw. Learn. Syst.*, vol. 29, no. 6, pp. 2063–2079, Jun. 2018.
- [5] P. Chriskos, C. A. Frantzidis, P. T. Gkivogkli, P. D. Bamidis, and C. Kourtidou- Papadeli, Automatic sleep staging employing convolutional neural networks and cortical connectivity images, *IEEE Trans. Neural Netw. Learn. Syst.*, vol. 31, no. 1, pp. 113–123, Jan. 2020.
- [6] Y. Shi, H.-I. Suk, Y. Gao, S.-W. Lee, and D. Shen, Leveraging coupled interaction for multimodal Alzheimer’s disease diagnosis, *IEEE Trans. Neural Netw. Learn. Syst.*, vol. 31, no. 1, pp. 186–200, Jan. 2020.
- [7] I. Almakky, V. Palade, Y.-L. Hedley, and J. Yang, A stacked deep autoencoder model for biomedical figure classification, in *Proc. IEEE 15th Int. Symp. Biomed. Imag. (ISBI)*, Apr. 2018, pp. 1134–1138.
- [8] Ambeth Kumar.V.D Dr.S.Malathi, V.D.Ashok Kumar (2015).Performance Improvement Using an Automation System for Segmentation of Multiple Parametric Features Based on Human Footprint. for the Journal of Electrical Engineering & Technology (JEET) , vol. 10, no. 4, pp.1815-1821 , 2015. [<http://dx.doi.org/10.5370/JEET.2015.10.4.1815>]
- [9] Ambeth Kumar.V.D et.al .A Survey on Face Recognition in Video Surveillance. *Lecturer Notes on Computational and Mechanism*, Vol. 30, pp: 699-708, 2019
- [10] Ambeth Kumar.V.D .Precautionary measures for accidents due to mobile phone using IOT. *Clinical eHealth*, Volume 1, Issue 1, March 2018, Pages 30-35.
- [11] S.V. Ruphitha et.al. “ Management of Major Postpartum Haemorrhage by using Zigbee protocol - A Review “, 2021 6th International Conference on Inventive Computation Technologies (ICICT) (DOI: 10.1109/ICICT50816.2021.9358757 )
- [12] M. Indhumathi et.al , “Healthcare Management of Major Cardiovascular Disease-A review”, 2021 6th International Conference on Inventive Computation Technologies (ICICT), (DOI: 10.1109/ICICT50816.2021.9358519 )

# Advanced Eyewear with Embedded Hardware for Woman Safety

Narendhiran.S <sup>a</sup>, Radhakrishnan.P <sup>b</sup>, and Elangovan. D <sup>b</sup>

<sup>a</sup>*UG Scholar, Dept of CSE, Panimalar Engineering College, Chennai, India*

<sup>b</sup>*Associate Professor, Dept of CSE, Panimalar Engineering College, Chennai, India*

**Abstract:** Human have always lived for the betterment of themselves but the bitter truth is that the process of modernisation has never focussed on making a safe society for women. The lack of self-reliance in women is one of the shortcomings of modernisation. An Advanced eyewear with an embedded camera will remove the barriers in a woman's life. The combination of wireless communication with IoT sensors increases its scope of use. The People under threat would be intervened with the security officials or alert the emergency contacts saved previously. This paper introduces a security purpose eyewear with the required embedded technology to enhance the life style of a woman. This would bring in quicker and reliable information to the security officials. This would eventually hamper the victimizer from his cruel intentions by creating a fear of being watched.

**Keywords:** self-reliance, wireless communication, navigation, threat detection, sensors.

## 1. Introduction

A sensor is an equipment which can detect changes in its surroundings and transmit the collected data to other electronic devices. Sensors are mostly used as auxiliary devices in a machine. If we look around us there would hardly be any device without an embedded sensor. One would find them in touch-sensitive elevator buttons i.e., the tactile sensor and in the automobiles to detect fast moving objects and perhaps in almost in everyday utility devices. Due to the recent advancements in technology especially in micro machinery, the uses of sensors are now found in new fields. One would still find the traditional sensors such as potentiometers to be still widely used. In most devices, the sensors are found to be the cheap and efficient components. They are easily replaceable when damaged[2][3]. They are manufactured in such a way that they are durable and their efficiency of its output is consistent. They were initially introduced in the 1800s for sensing temperature based on the criteria of copper resistance. Since then, the sensors have changed the world. They are used to provide information about the presence or absence of a physical object. They simulate the were

---

<sup>1</sup>Radhakrishnan P, Assistant Professor, Dept of CSE, Panimalar Engineering College, Chennai, India  
Email id : rksival3@gmail.com

human senses to detect the presence of a special physical object. For example, Ultrasound sensors respond to reflected sound waves and the information collected is then used to measure distance[2].

### *A. Auditory sensor*

As the name suggests these sensors detect sound and respond by giving information about the sound level. The operation of these sensors is similar to the processes in the human body that involves our ears and signals being sent to the brain[3]. Measurement of sound is done in decibels (dB). When a person is found to be talking in a normal voice, the sound levels produced from microphone on an average is between ~40 to 60 dB, whereas when the person is talking loudly, the membrane of the microphone vibrates more rapidly reaching sound levels to about 90 dB.

### *B. Pulse Sensor and CMOS Sensor*

Companies like Arduino provide the pulse detection sensors which uses the concept of monitoring the heart rate. A heart rate monitor (HRM) could be any device that measures and displays the in real time or record the heart rate for later study. It is largely used to collect heart rate data while performing various types of physical exercises. heart rate. It is mostly used to monitor the heart rate while the person is performing various types of physical exercises. On Comparing ourselves from the previous generations one would find that taking pictures has become cheaper. Present technology includes sensors such as CMOS sensors which detect photons from the surroundings and convert it into electrical signals. CMOS has lesser manufacturing cost than other technologies such as CCDs. If we compare CMOS with other sensors, we would find that almost all of them use similar technologies. The basic principle of detecting the light and converting the detected data into electrical signals and storing them into a storage media . This results in less area for the capturing of photons than a CCD. To acquire photons even from smaller area micro lens is used which can then focus on the photodiodes. Thus, the aforementioned sensors have made possible the detection and transmission of data from the environment efficiently.

## **2. Existing System**

In this modern era, sensors[4] have become the requisites of any luxury good. They have conquered almost every aspect of human life. Nowadays, they are even used in automobiles, medicine smart phones, malls and home appliances. They have entered into our lives intervening between us and the computers. To upload pictures of oneself and one's lifestyle has become the recent trend. In the current trend, What's more intriguing is that being incognito is considered as absurd by the present young minds. Thus, people try to live in a virtual world denying the reality. They have trained themselves not to trust anyone lest they be harmed. The darker side is that they are in a verge to become unreliable. So, an advanced eyewear would connect the vulnerable to the previously saved emergency numbers whom one may consider as a family member, friend, acquaintance or the security officials. The feeling of insecurity among the majority of the population in the world had led to companies like apple to introduce

emergency SOS which alerts the emergency contacts through text messages along with location. However, this has not reduced the significant number of crimes around the world due to the inability of people to use it efficiently. A camera embedded in the spectacles would perhaps capture the faces around a vulnerable woman and a basic voice recorder would explain the situation experienced by her. This security system can also be made available to the men who have a fear of facing any threat in their day today life. The Safety of women's is also great issue due to increasing crime at an alarming rate against women across the globe. A GPS based women's safety system is proposed to resolve which has two security feature [11-18]. The system which is turned on to generate two alert , if in case a woman is harassed or when she is in trouble. The project proposed device it helps to turning on the device , if woman thinks that she feels alone while walking on the road or any remote area or some dark alley. The woman can authenticated the devices can start the system by using fingerprint scan. Once the device started recording every minute and every second photo and video are captured and authorized personnel number through SMS or to corresponding nearby the police station . In case, if stranger hits the woman on the other hand woman falls down and becomes unconscious, if she is not able to do nothing, the device works automatically starts the dual security features. The device is useful for the women in day to day life and also preventing atrocities against women. There are some proposed systems already existing which talk about the advanced spectacles with embedded hardware such as camera and various applicable sensors [1]. But this proposal has never touched the concept of safeguarding modesty. The architecture of the processing never stops with the spectacles or the smart phone but connects to the appropriate individuals or the official security related groups. This would bring in the fear within the oppressor and hamper him/her in their pursuit of personal whims and gains.

### **3. Proposed System**

One may always fear the menace of life, property, chastity, family welfare and so on. The most important one in this project is to press a button for ensuring security. This would activate the camera embedded in the spectacles. Eventually, a wireless communication will be established between the user and the accountable authority i.e., it would alert the emergency contacts which were previously saved or the nearest situated police station or the hospital via a text message and the pictures of the surroundings taken by the camera will be continuously sent to the same. The audio receiver embedded in the spectacles would transmit the currently recorded audio to the needed. The person on the other side of communication may inform the required officials if not informed when a dire need is felt The device suggests you new method of how files are stored in the app by applying the existing encryption method and mobile system. The users are not comfortable about the fact that that their extremely private or confidential files can be accessed for various purposes by the eyewear hardware. However, this can never happen until the smart phone is hacked. These are the reasons to protect women's safety and protection. However, users can only use the eyewear for safety purposes. Eyewear is the project which is mainly used for women's safety. Eyewear is mainly used to find strangers who had involved into insensitive activities against women. In India, especially women are unsafe and in order to avoid these problems we are proposing this system to rescue the women from these threats and also to give vulnerable men to boost their confidence under fearful situations. The



It breaks the barrier between the victim and the security officials and boosts the speed of acquiring help. This system would bring out the confidence in the people who feel that they are prone to danger. The lives would become simpler with fast communication during inflictions which would finally lead to fear within criminals. Hence, the number of perpetrators of any crime would see a decline within reasonable time. In future this project can be improved further by integrating Aadhaar number into the device. The device can further be made lighter by embedding expensive hardware into the device. This system can also be extended for the general conversations between individuals or groups.

## References

- [1] Jianliang Meng, Junwei Zhang, Haoquan . Overview of the Speech Recognition Technology. Fourth International Conference on Computational and Information Sciences (2019) .
- [2] Huang Shan . Voice recognition systems in the telecom prepaid business applications. Information Science (2010).
- [3] Alina Munir, Kashif Ehsan S, S. M. Mohsin Raza, Mumajjed Mudassir . Face and Speech Recognition Based Smart Home An offline Security and Automation System (2010) .
- [4] Subhas Chandra Mukhopadhyay , Wearable Sensors for Human Activity Monitoring: A Review (2011).
- [5] Kiritsis, D., 2011. Closed-loop PLM for intelligent products in the era of the Internet of things. *Computer-Aided Design*, 43(5), pp.479-501.
- [6] Stojkoska, B.L.R. and Trivodaliev, K.V., 2017. A review of Internet of Things for smart home: Challenges and solutions. *Journal of Cleaner Production*, 140, pp.1454-1464.
- [7] Ejaz, W., Naeem, M., Shahid, A., Anpalagan, A. and Jo, M., 2017. Efficient energy management for the internet of things in smart cities. *IEEE Communications Magazine*, 55(1), pp.84-91.
- [8] Varshney, U. and Snea, S., 2006. Patient monitoring using ad hoc wireless networks: reliability and power management. *IEEE Communications Magazine*, 44(4), pp.49-55.
- [9] Cao, H., Leung, V., Chow, C. and Chan, H., 2009. Enabling technologies for wireless body area networks: A survey and outlook. *IEEE Communications Magazine*, 47(12), pp.84-93
- [10] Cloete, A.H., Brown, J.W.K., Booysen, M.J., Steinke, R. and Magedanz, T., 2016. Smart Grid Application using ETSI M2M: Domestic Electric Water Heaters. SAUPEC 2016 Proceedings.
- [11] Ambeth Kumar.V.D, Dr.S.Malathi, V.D.Ashok Kumar (2015). Performance Improvement Using an Automation System for Segmentation of Multiple Parametric Features Based on Human Footprint. for the *Journal of Electrical Engineering & Technology (JEET)* , vol. 10, no. 4, pp.1815-1821 , 2015. [<http://dx.doi.org/10.5370/JEET.2015.10.4.1815>]
- [12] Ambeth Kumar.V.D , S.Ramya , H.Divakar , G.Kumutha Rajeswari .A Survey on Face Recognition in Video Surveillance”, *Lecturer Notes on Computational and Mechanism*, Vol. 30, pp: 699-708, 2019
- [13] Ambeth Kumar.V.D, Precautionary measures for accidents due to mobile phone using IOT. *Clinical eHealth*, Volume 1, Issue 1, March 2018, Pages 30-35.
- [14] K. Nanagasabapathy et.al. Validation system using smartphone luminescence. *IEEE International Conference on Intelligent Computing, Instrumentation and Control Technologies (ICICT)*, Pages: 235 – 239, 6-7 July 2017, Kannur, India
- [15] Ambeth Kumar.V.D et.al; . Cloud enabled media streaming using Amazon Web Services. *IEEE International Conference on Smart Technologies and Management for Computing, Communication, Controls, Energy and Materials (ICSTM)*, Pages: 195 – 198, 2-4 Aug. 2017, (DOI: 10.1109/icstm.2017.8089150)
- [16] Aravindh.B et.al, .A novel graphical authentication system for secure banking systems. *IEEE International Conference on Smart Technologies and Management for Computing, Communication, Controls, Energy and Materials (ICSTM)*, Pages: 177 – 183, 2-4 Aug. 2017, Vel Tech University, Chennai, India
- [17] Ambeth Kumar.V.D et.al, “An Efficient Security System for Data base Management from Illegal Access. *IEEE International Conference on Wireless Communications, Signal Processing and Networking (WiSPNET)*, SSN Engineering College, Chennai, India, 23-25 March, 2016
- [18] Ambeth Kumar.V.D and Dr.M.Ramakrishan (2011). Web Cam Motion Detection Surveillance System Using Temporal Difference and Optical Flow Detection with Multi Alerts. *(CCIS) Journal (Springer) Volume 147, Part 3, pp: 214-221, 2011, April 2011* and the paper was published in the *International Journal*. [Impact Factor: 0.247]. [DOI: 10.1007/978-3-642-20573-6\_34]



# Intelligent Waste Classification System Using Vision Transformers

Menti Aditya Gowrish<sup>a,1</sup>, Mukesh Kumar Dahlan<sup>b</sup>, R. Subhashini<sup>c</sup>  
<sup>a,1,b</sup>UG Scholar, Dept of CSE, Sathyabama Institute of Science and Technology,  
Chennai, India

<sup>c</sup>Professor, Dept of IT, Sathyabama Institute of Science and Technology, Chennai,  
India

**Abstract.** The issue of waste management is a growing concern, ranging from agricultural fields to industries and villages to cities. Our project aims to contribute to this issue by solving the problem of segregation of waste by using the latest advances in computer vision. The Transformers for Image Recognition at Scale, which will give highly efficient results in less time compared to the models based on Convolutional Neural Networks which loses a lot of valuable information and ignores the relationship between part of images and as a whole. The Self-Attention in vision transformers gives them the capability to understand the connection between inputs, where operations can be processed in parallel on multiple GPUs and CPUs, which cannot be achieved in the case of Convolutional Neural Networks. This project allows us to build an effective system that can classify waste in real-time without human intervention in large scale industries and also in a regular household.

**Keywords.** Vision Transformers, Convolutional Neural Networks, Self-Attention, Image Recognition, Computer Vision.

## 1. Introduction

Every Year more than 3 billion ton of garbage or waste is generated all over the globe where metropolitan areas alone contribute large number to this. The amount of waste materials produced will increase by more than 70% by the year 2024. The classification of garbage using hands where people are hired for categorizing the garbage or materials. The person whoever separates the garbage material is at the risk of facing different kinds of health issues because of the toxic chemicals and substances present within the garbage. The above health issue is overcome by proposing a system called “Intelligent Waste Classification System Using Vision Transformer(Vit)”. The ViT considers an input image as a series of blotch, Akin to a series of word embedding’s generated by a natural language processing (NLP) Transformer. It demonstrates excellent performance when trained on sufficient data outperforming a comparable state-of-the-art CNN(Convolutional Neural Network) with four times fewer

---

<sup>1</sup>Menti Aditya Gowrish, UG Scholar, Dept of CSE, Sathyabama Institute of Science and Technology, Chennai, India.

E-mail: aditya.menti@gmail.com

computational resources. The "Intelligent Waste Classification System using Vision Transformer" management procedure of the waste materials is going to speed up and the advantage of this system does not involve any individual.

## 2. Motivation

The old and traditional procedure of classifying garbage or waste materials using human hand by hiring persons for separating different types of waste objects. The one who separates waste is at risk of facing various health problems due to the harmful and toxic substances present within the material or garbage. By keeping this in mind, an automated system is developed which can separate the waste materials into their respective groups. This intelligent and accurate waste classification system takes less time to segregate the waste than the physical way. The separation of garbage or waste material is going to be salvage and can be translated into different forms of power and propellant for the development of the country's wealth.

## 3. Objective

The proposed model "Intelligent Waste Classification System using Vision Transformer" follows an efficient procedure to segregate the waste. It classifies the garbage or waste materials such as glass objects, metal objects, paper objects, cardboard, plastic objects and trash using an intelligent waste classification system instead of a hand-picking method. The advantage of this system is that it decreases the training time significantly. It understands the connection between inputs. It handles variable sized input using stacks of self-attention instead of CNNs and RNNs.

## 4. Related Work

### 4.1 Fine-Tuning Models Comparison Garbage

UmutOzkaya et al. (2018) aimed to build a deep learning application which recognizes different kinds of trash in garbage to furnish recyclability with vision framework. Two distinct classifiers namely Support Vector Machines and Softmax were utilized to check the execution of different classifiers and six distinct kinds of images of garbage were accurately characterized with the highest accuracy of 97.86% with GoogleNet+SVM.

### 4.2 Intelligent Waste Classification System Using Deep Learning Convolutional Neural Network

Olugboja Adedeji et al. (2019) developed this deep learning tool by utilizing 50-layer Residual Network pre-train CNN architecture that is a deep-learning tool as well as a feature extractor and Support Vector Machine that is employed to differentiate the waste into six classes namely cardboard, paper, glass, metal and plastic etc. The planned model was tested on the data set that was built by Gary Thung and Mindy Yang which was able to attain 87% accuracy [1].

### 4.3 Visual Transformers: Token-based Image Representation and Processing for Computer Vision

BichenWu et al.(2020) developed this model where it represents images as semantic visual tokens and then it runs these into transformers to densely model token relationships. The Visual Transformer works in a semantic token space attending to different parts of image based on context which is in sharp contrast to pixel-space transformers that requires orders-of-magnitude and more compute. Vision Transformer using advanced training methods significantly outperform their convolutional Neural Networks raising Residual Networks accuracy on ImageNet dataset by 4.6 to 7 points while using lesser FLOPs and parameters. In the case of semantic segmentation on LIP dataset and COCO-stuff dataset, Vision Transformer based feature pyramid networks (FPN) achieves 0.35 points greater mIoU while decreasing the FPN module's FLOPs by 6.5x.

### 4.4 An Image is Worth 16x16 Words: Transformers for Image Recognition at Scale

Alexey Dosovitskiy et al.(2020) argued that in Computer vision, attention is used in concurrence with CNN's or used to substitute some parts of CNN's keeping its entire structure in place. They showed that this dependence on Convolutional neural networks is not required and a sequence of patches of an image is given to a pure transformer directly that performs image classification very well. Once the model is pre-trained on huge quantities of information and then when they are transferred to multiple different-sized image classification benchmarks (VTAB, CIFAR-100, ImageNet, etc.), Vision Transformer (ViT) is able to attain marvelous results when weighed against the state of the art CNN's, all while training on considerably lesser computational resources[2].

## 5. Existing System

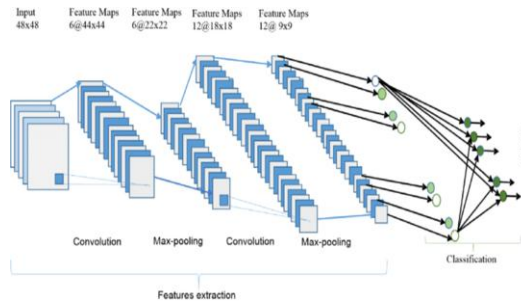
A Convolutional Neural Network (ConvNet/CNN) is a Deep learning algorithm that is able to differentiate one image from another by assigning learnable weights and biases to various features of input images. The preprocessing that is required in a Convolutional Neural Network is a considerably less weighed against other classification algorithms. At the same time as in basic methods, with sufficient training Filters are hand engineered, Convolutional Neural Networks can study these filters or traits. The Convolutional Neural Network classifies the images by analyzing an image to know if some definite parts of the image are present in that image or not. A single scalar is outputted by Neurons in ANN's except CNN's utilize convlayers that for each kernel, it replicates the same kernel's weights across the entire input volume which produces an output 2D matrix of replicated feature detector. With a part of the input volume, every number is the output of that kernel's convolution. Then, all kernel's 2D matrices are stacked on top of one another to provide an outcome of a convolutional layer. Then, it is attempted to obtain perspective in-variance within the actions of neurons through the approach of maxpooling that consecutively selects the largest number in each region by looking at places inside the above defined 2D matrix. As an end result, we get invariance of activities. The invariance indicates that with the aid of converting the input a little, the same outcome still remains. The output signal of a neuron is called as an activity. In a nutshell, networks activities will no longer change

due to maxpooling even if we shift the object that we want to detect by a little bit and the network will nevertheless detect the object within the input image. The mechanism described above is not always useful, because maxpooling loses important data and does not encode relative spatial relationships between different features of the input images. Because of this, the Convolutional Neural Network is not always fixed to large transformations of input data.

### 5.1 Disadvantages of Existing System

- CNN fails to encode relative spatial information, but good to identify certain features in the input image but it does not consider the positioning of those features with respect to each other.

**Figure 1:** The overall architecture of the Convolutional Neural Network.



- CNN makes the predictions by means of analyzing an input image after which inspecting to check if some of the components that it previously analyzed are present in that image or not.
- The numbers starts at 1 with every call to the enumerate environment.
- CNN is not always invariant to large transformations of the input data.
- Parallel Processing is not possible with CNN's.

## 6. Proposed System

The Vision transformer System (model) is applied to attain excellent results with pure transformer architecture applied directly to a sequence of image patches for classification tasks. Additionally, it outperforms the state-of-the-art convolutional networks on several image classification tasks by using substantially fewer computational resources (at least four times fewer than SOTACNN) to pre-train. An automated classification system employing a deep learning algorithm has been used to segregate or differentiate wastes into different groups. The implementation of a well-planned system that can classify waste efficiently will increase recycling rate and reduces the burial of waste in the soil and oil pollution. The careful and robust classification of waste materials is very essential given the strict controls needed for storage, treatment and disposal of hazardous waste.

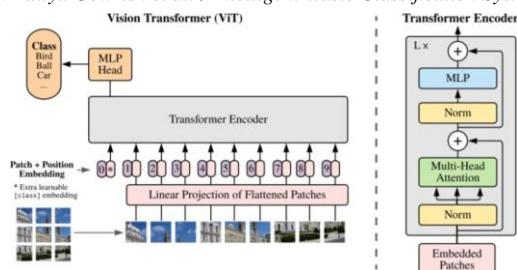


Figure 2: The overall architecture of the Vision Transformers.

The regular transformers use words to learn about sentences whereas Vision transformer uses pixels to achieve a similar result for images. In contrast to words, individual pixels do not convey any meaning by themselves which was one of the reasons we shifted to convolutional filters that operated upon a group of pixels. Therefore, we divide the whole image into small patches or words. All the patches are flattened using a linear projection matrix and fed into the transformer with their positions in the image. The Vision transformer model grasps to encode the distance within the input image similar to that of positional embedding. The closer patches in the input image tends to have more identical positional embedding. The column and row structure appears as patches in the same column or row will have similar positional embedding. A sinusoidal structure is sometimes apparent for larger grids. These embedded patches go through alternating layers of multi-headed self-attention, multi-layer perception (simple feed-forward neural network) and layer normalizations like in a regular transformer. Even in the lowest layers, the Self-attention in Vision Transformer allows them to amalgamate information across the entire input image. It is examined to check what degree the network makes use of this capability. A classification head is attached at the end of the transformer encoder to predict the final classes. Like any other convolutional model, one can use the pretrained encoder base and attach a custom Multi-Layer Perception (MLP) layer for fine tuning the model to suit their classification task.

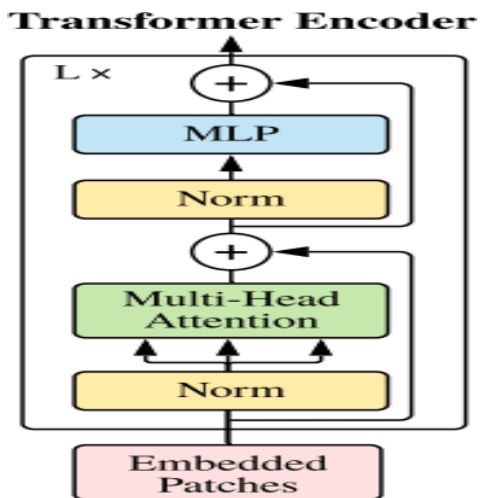


Figure 3: Architecture Diagram of Transformer Encoder.

Model	Layers	Hidden size $D$	MLP size	Heads	Params
ViT-Base	12	768	3072	12	86M
ViT-Large	24	1024	4096	16	307M
ViT-Huge	32	1280	5120	16	632M

**Figure 4:** Details of Vision Transformer model variants.

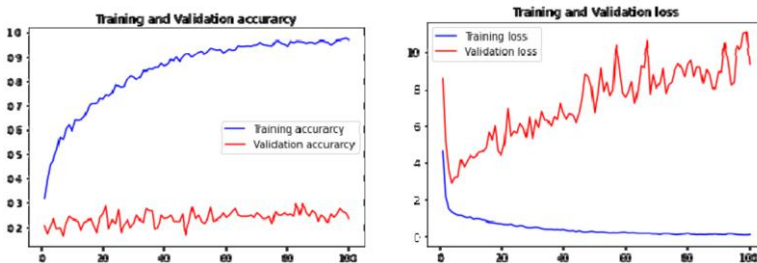
### 6.1 Advantages of Proposed System

- Vision Transformers encode relative spatial information. It not only detects features in the image but also considers their positioning with respect to each other.
- Self-attention allows Vision Transformer to integrate information across the entire input image even in the lowest layers.
- It uses substantially fewer computational resources.
- Self-Attention in vision transformers gives them the capability to understand the connection between inputs where operations can be processed in parallel on multiple GPUs and CPUs.
- Parallel Processing is possible with Vision Transformers.

## 7. Result and Discussion

The ViT model achieves about 78.89 percent accuracy and 93 percent top five accuracy on the test data after 100 epoch on the waste classification dataset. These findings are not competitive as a CNN trained from scratch on the same data can achieve 87 percent accuracy.

We can try to train the model for more epochs using a greater number of transformer layers, resize the input images, adjust the patch size or increase the projection dimensions to boost the model quality without pre-training.



**Figure 5:** Training and Validation Accuracy and Training and Validation Loss

## 8. Conclusion

This model will make the system of waste management more efficient and flexible. The automatic classification of waste is made easier by this method without human

involvement. Consequently, it prevents contamination and different types of harmful pollution. When tested against the trash data sets, the accuracy level lasted of 78.89%. The classification procedure of the waste objects will be much quicker by using this system. When more images are provided to the dataset, then the system accuracy can be improved. In the future, more vast technology is used to improve the system to manage and classify more waste items.

## References

- [1] Olugboja Adedeji, ZenghuiWang Intelli- gent Waste Classification System Using Deep Learning Convolutional Neural Network, 2nd International Conference on Sustainable Materials Processing and Manu facturing, 607–612, 2019
- [2] UmutÖzkaya and LeventSeyfi, “Fine-Tuning Models Comparisons on Garbage Classification for Recyclability”,1(2),pp: 1-14, (2018).
- [3] BichenWu, ChenfengXu, XiaoliangDai, Visual Transformers: Token-based Image Representation and Processing for Computer Vision, 5(2), pp: 1-14, (2020).
- [4] Alexey Dosovitskiy, Lucas Beyer, Alexander Kolesnikov, An Image is Worth 16x16 Words: Transformers for Image Recognition at Scale, pp:1-8, (2020).
- [5] <https://towardsdatascience.com/wtf-is-image-classification-8e78a8235acb>
- [6] <https://towardsdatascience.com/end-to-end-pipeline-for-setting-up-multiclass-image-classification-for-data-scientists-2e051081d41c>
- [7] <https://medium.com/swlh/convolutional-neural-networks-for-multiclass-image-classification-a-beginners-guide-to-6dbc09fabbd>
- [8] [https://scikit-learn.org/stable/user\\_guide.html](https://scikit-learn.org/stable/user_guide.html)
- [9] [https://devdocs.io/scikit\\_learn/](https://devdocs.io/scikit_learn/)
- [10] <https://medium.com/analytics-vidhya/vision-transformers-bye-bye-convolutions-e929d022e4ab>
- [11] <https://medium.com/lsc-psd/introduction-of-self-attention-layer-in-transformer>
- [12] R. Subha Shini et.al., “ Recurrent Neural Network based Text Summarization Techniques by Word Sequence Generation”,IEEE International Conference on Inventive Computation Technologies (ICICT), 2021, DOI: 10.1109/ICICT50816.2021.9358764

This page intentionally left blank



# Computing and Communication

This page intentionally left blank

# Experimental Investigation of Pulse Modulation Schemes in Free Space Optical Communication Under Turbulence

Y.P. Arul Teen<sup>a,1</sup>, NimmyLazer<sup>b</sup>, J.M. Aravind<sup>c</sup> and Rajesh K. B.<sup>d</sup>

<sup>a</sup>Department of ECE, University College of Engineering, Nagercoil, India

<sup>b</sup>Department of ECE, Marthandam College of Engineering & Technology, Tamilnadu, India

<sup>c</sup>Department of ECE, Mar Ephraem College of Engineering & Technology, Tamilnadu, India

<sup>d</sup>Department of Physics, Chikkanna Government Arts College, Tirupur, India

**Abstract.** When we allow an optical beam to travel through Free Space Optical (FSO) Communication system, the optical beam faces immense issues due to so many factors such as diffraction, scattering, signal absorption, etc. These factors put down the quality rate of FSO communication system. In this experimental analysis, an artificial controlled turbulence chamber was built to create FSO communication with optical source laser. The signal to be tested is generated with the help of a LASER source, is allowed to pass on through the immense turbulent states by employing various pulse modulation schemes such as Pulse Amplitude Modulation (PAM), Pulse Duration Modulation (PDM), and Pulse Position Modulation (PPM) separately. In all the three modulation schemes, the parameters such as phase Jitter and 3dB bandwidth are observed and the observed values are compared. The results show that phase jitter value is 9.8414 radians for PPM. Also, PPM has the highest ability to overcome jitter than the remaining two schemes under high atmospheric turbulence parameters. However, in the case of Bandwidth utilization, PDM modulation reduces its utilization to 12MHz.

**Keywords.** Free Space Optical communication; PPM; PAM; PDM; Phase Jitter; 3dB bandwidth, performance, measurement.

## 1. Introduction

In the current scenario, free space optical (FSO) communication focuses a deep attentiveness in optical community because of its immeasurable advantages such as huge amount of data transmission over unlicensed spectrum, wireless communication technique used to send and receive various types of data at faster rate, larger bandwidth, gives high performance in optical networks, etc. [7-12]. Although, along with the advantages FSO faces certain troubles due to the presence variety of turbulent factors present in the environment which effects its performance [1,13]. FSO chooses Laser as

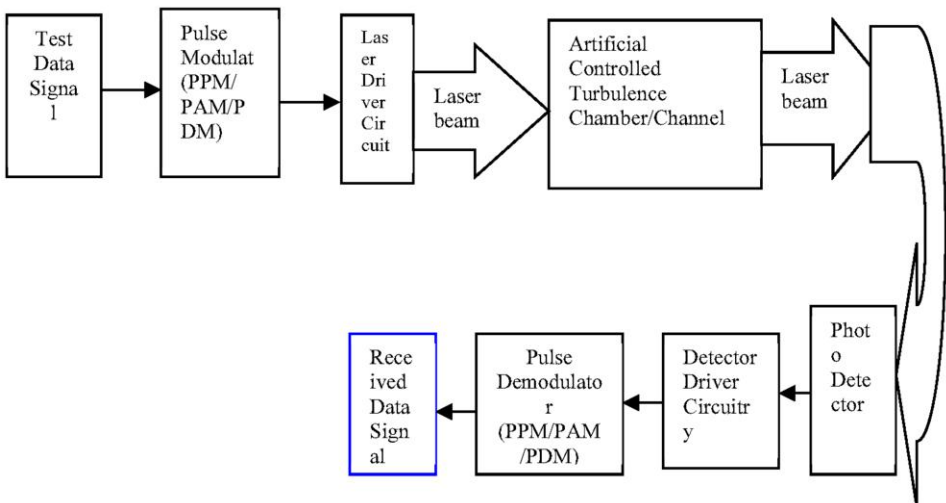
---

<sup>1</sup>Y.P. Arul Teen, Dept of ECE, University College of Engineering, Nagercoil, TamilNadu, India.  
Email: arulteen@yahoo.co.in

an optical source compared to other sources, but the transmitted signal over atmosphere get distorted due to turbulence. Experimental demonstration of OOK and BPSK-SIM modulation schemes on scintillation in fixing the threshold value on an FSO system is shown in [2,14]. The presence of turbulence causes error in the received data [13]. By properly observing the jitter values the degree of deviation of the received signal from the actual transmitted can be found out clearly. A variety of statistical models were used for studying the impact of pointing errors on FSO communication systems [5-6]. By using PPM, a good channel capacity can be achieved in an optical link [15]. In PAM, data is transmitted by varying the amplitudes of the individual pulses. In PDM, long pulses expend considerable power while bearing no additional information [18]. Here, phase jitter, time jitter, and 3dB parameters are used for FSO analysis experimentally by using various modulation schemes for propagating the data in a specially designed artificial turbulence chamber for FSO communication and the outputs are compared. Description of problem and FSO test bench are discussed in section 2. The results and discussion is highlighted in section 3 and section 4 deals with conclusion [19-21].

## 2. Problem Description and FSO Test Bench

The quality of transmitted data can be degraded due to the fluctuation in phase and intensity of laser beam [14, 18]. The range of FSO link, atmospheric attenuation and pointing error under various weather conditions have been studied [4]. Compensation of phase fluctuation is very essential to achieve a very high data rate. Scintillation, beam spreading and beam wandering are some other problems that affects laser beam [17]. Therefore, proper studies and compensation techniques are important so that the reliability of data transmission through FSO can be increased.



**Figure 1.** Free Space Optical Communication Test Bench Experimental Setup

The test bench setup used for experimenting FSO system is shown in Figure 1, which consists of a transmitter-receiver for transmission and receiving data, and channel for communicating. In the transmitter section, signal generator is used to generate test

data. The modulating signal frequency is 4 KHz. The modulation scheme may be either PPM or PAM or PDM. The laser source is driven by the modulated signal and the wavelength of laser ranges between 650-680nm. The test bench maintains line of sight between transmitter and receiver ends. The separation between both ends are maintained as 125cm throughout the experiment. The optical beam after modulation travels through the turbulence chamber. The turbulence chamber is artificially filled with various atmospheric turbulence components such as smoke and fog. The LASER beam affected by the various turbulence inside the chamber are allowed to receive by the PIN photo detector. By applying the demodulation in a proper manner, we can measure the phase and time jitter with the help of a spectrum analyzer. The experiment is repeated for each pulse modulation technique namely PPM, PAM, and PDM. Turbulence chamber dimension is 125x25x25 cm<sup>3</sup>. The temperature inside the chamber is regulated in such a way that it will always maintains 45 degrees and also, from the beginning till the end of the experiment turbulence conditions were maintained constant.

### 3. Results and Discussion

The FSO system explained above is tested experimentally by the proposed artificial turbulence chamber. In this experiment, the frequency spectrum with center frequency is 1.5GHz and span of frequency is 3GHz are considered. First, the system is tested by giving test data as input to different modulation scheme (PAM, PDM, PPM) under without turbulence. The output readings are taken using standard spectrum analyzer, which is connected with the demodulation kit. Figure 2 shows the phase and time jitter measurement using spectrum analyzer for different modulation scheme without turbulence. The phase and time jitter measurement in PAM with no turbulence is shown in figure 2(a) and the output shows that 9.8598 radians and 1.0955nsec is the value for phase and time jitter. Same analysis method and modulation scheme is employed in PDM with no turbulence and figure 2 (b) represents the result. It is monitored that the 9.854 radians and 859.55psec is the value for phase and time jitter. When using PPM, 7.7359 radians and 1.0972nsec is the value for phase and time jitter, which is shown in figure 2 (c).

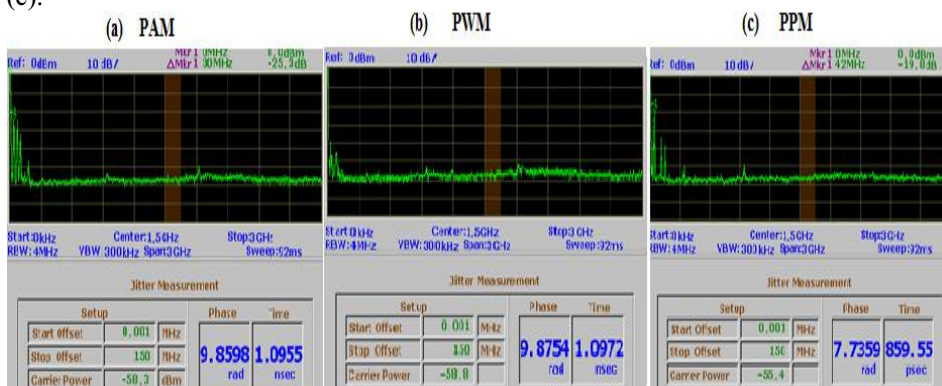


Figure 2. Phase and time jitter without turbulence, a) PAM b) PDM c) PPM

Figure 3 represents the phase and time jitter measurement using spectrum analyzer for different modulation scheme with turbulence. The phase and time jitter measurement in PAM with turbulence is shown in figure 3(a) and it is monitored that 10.445 radians and

1.1605nsec is the value for phase and time jitter. Same procedure is done using PDM in the presence of turbulence, which is shown in figure 3 (b), the observed value is 10.195 radians and 1.1329psec for phase and time jitter. When using PPM modulation, the noted phase jitter is 9.8414 radians and time jitter is 1.0934nsec and it is representing in figure 3 (c). Next, bandwidth utilization is analyzed experimentally for all the different three modulation schemes without and with turbulence.

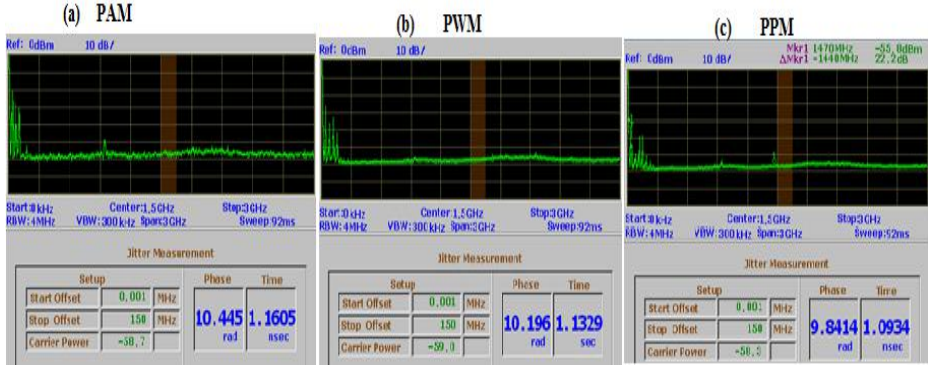


Figure 3. Phase and time jitter with turbulence, a) PAM b) PDM c) PPM

The 3dB measurement of bandwidth utilization is measured using spectrum analyzer for different modulation scheme under without turbulence conditions. The 3dB bandwidth measurement using PAM without turbulence is observed as 30MHz. The same method applied for PDM and PPM under without turbulence, the bandwidth is 30MHz for PDM and 12MHz for PPM. The 3dB measurement of bandwidth utilization with turbulence condition shows that using PAM, the bandwidth is 30MHz. For PDM and PPM under turbulence conditions bandwidth is 12MHz and 30MHz. The experimental results of different pulse modulation techniques with and without turbulence of phase and time jitter is shown in table 1. In which it is clearly shows the phase jitter is very low in PPM when compared with PDM and PAM under with and without turbulence conditions. From this it is clearly analyzed and verified that the huge amount of data transmission over unlicensed spectrum, wireless communication technique with high performance computing will send and receive various types of data at faster rate, larger bandwidth, gives high performance in optical networks, etc. Therefore, in optical high performance networks, using laser as optical source and selecting PPM modulation scheme for modulating laser source, we can achieve high data transmission rate with less jitter.

Table 1. Comparison of Modulation schemes

Parameter	PAM		PDM		PPM	
	Without Turbulence	With Turbulence	Without Turbulence	With Turbulence	Without Turbulence	With Turbulence
Phase Jitter	9.8598rad	10.445rad	9.8754rad	10.196rad	7.7359rad	9.8414rad
Time Jitter	1.09555nsec	1.1605nsec	1.0972nsec	1.1329nsec	859.55picosec	1.0934nsec
3dB Bandwidth	30MHz	30MHz	30MHz	12MHz	12MHz	30MHz

### 4. Conclusion

It is apparent from the results that over dense atmospheric turbulence, the signal strength immunity level of PDM and PAM are very low than that of PPM. Very high phase jitters are observed in PDM and PAM making them in efficient modulation techniques for consistent data transmission over FSO. Results shows that PPM is the best modulation technique based on Jitter analysis. In the point of view of bandwidth utilization, PDM is the best choice than PPM, but in the case of phase and time fluctuation, PPM is considerable modulation choice. Therefore, in optical high performance networks, using laser as optical source and selecting PPM modulation scheme for modulating laser source, we can achieve high data transmission rate with less jitter. Work is currently in progress to increase the length of channel and by applying other digital modulation techniques to identify Jitter performance.

### Annexure:

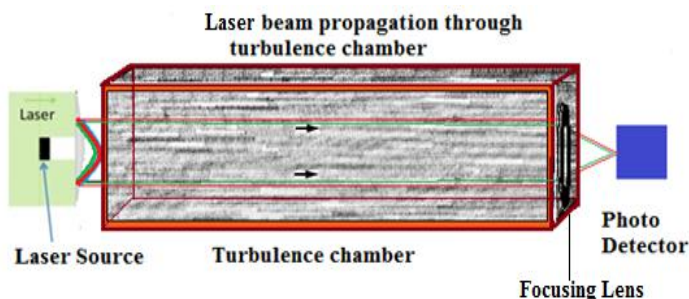


Figure 4.Laboratory FSO experimental setup

Table 2. Experimental System Parameters

Laser Source	Turbulence Chamber	Focusing Lens	Photo Diode
Laser color: RED Wavelength:650nm±10 Laser max. output power: 3mW Grade: Class IIIA(Betatx) Size :65 x 14 x 14mm.	Dimension:125x25x25cm <sup>3</sup> Artificial Turbulence: Fog and Smoke Condition: 45°C	Type: Convex type Material=UV fused silica with refractive index value n is 1.4585. Lens diameter=12.5mm . Edge thickness =4mm. Focal length : 13.1mm	Silicon NPN type :2N5777

### References

- [1] Chaleshtory, Z.N., Gholami. A., Ghassemlooy. Z., and Sedghi. M. Experimental investigation of environment effects on the FSO link with turbulence. IEEE Photonics Technol. Lett. 2017; 29(17): 1435–1438
- [2] Dabiri. M.T. and Sadough. S.M.S. Generalized blind detection of OOK modulation for free-space optical communication. IEEE Commun. Lett. 2017; 21(10): 2170–2173
- [3] Ytian,,Tianwen,, Shuang,Shijie,Huibin. Timing jitter’s influence on the symbol error rate performance of the L-ary pulse position modulation free-space optical link in atmospheric turbulent channels with pointing errors.Journal of Optical Engineering. Mar 2017; 56(3): 036116-1-3.
- [4] Adela.M, Seleem, Nasr, El-Khobby. Transmission of 128Gb/s Optical QPSK Signal over FSO Channel under Different Weather Conditions and Pointing Errors. IOP Publishing-Journal of Physics: Conference Series. 2020; 1447 -012055: 1-7

- [5] Ruben. B.R, Antonio. G.R, Carmen. C.V, and Beatriz. C.V. Novel approximation of misalignment fading modeled by Beckmann distribution on free-space optical links.OPTICS EXPRESS. Oct 2016; 24(20): 22635-22649.
- [6] Roumelas, Nistazakis, Leitgeb, Stassinakis, Tombras.On the performance of optical wireless communication links impaired by time jitter, M-turbulence and pointing errors.Journal of Optics Communication. Apr 2020; 472 (126033): 1-8.
- [7] Andrews L,Philips R.L, and Hopon C.Y.Laser Beam Scintillation with Applications.SPIE Press. 2001.
- [8] TsiftisT.A,Sandalidis.H.G,KaragiannidisG.K,SagiasN.C. Multihopfree-spaceoptical communications over strong turbulence channels.IEEE ICC Proc. June 2006; 2755-2759.
- [9] Gagliardi.R and Karp.S .Optical Communications.Wiley. 1995.
- [10] Willebrand H and Ghuman.B.S. Free Space Optics: Enabling Optical Connectivity in Today’s Network. IN: SAMS. 2002.
- [11] Safari M and Uysal M. Relay-assisted free-space optical communication.IEEE Transactions on Wireless Communications. Dec 2008; 7(12): 5441 – 5449.
- [12] Theodoros. A. Tsiftsis, Harilaos G. Sandalidis, George K. Karagiannidis, and Murat Uysal. OpticalWirelessLinkswithSpatialDiversityoverStrongAtmosphericTurbulence Channels. IEEE Transactions On Wireless Communications. Feb 2009; 8(2): 951-957
- [13] Deva K. Borah, Member, and David G. Voelz.Pointing Error Effects on Free-Space OpticalCommunicationLinksinthePresenceofAtmosphericTurbulence.JournalOf Light wave Technology. Sept 2009; 27(18): 3965-3973
- [14] Popoola WO and Ghassemlooy Z. Scintillation effect on intensity modulated laser communication systems—a laboratory demonstration. Journal Of Optics & Laser Technology. June 2010; 42: 682–692
- [15] Peppas KP and Datsikas CK. Average Symbol Error Probability of General-Order Rectangular Quadrature Amplitude Modulation of Optical Wireless Communication Systems Over Atmospheric Turbulence Channels. 102 J. Opt. Commun.Netw. Feb 2010; 2(2): 102-110.
- [16] LatsaBabuPedireddi and BalajiSrinivasan.Characterization of Atmospheric Turbu- lence Effects and their Mitigation Using Wavelet-Based Signal Processing. IEEE Transactions On Communications. June 2010; 58(6): 1795-1802
- [17] Majumdar AK. Free-space laser communication performance in the atmospheric channel. J. Opt. and Fiber Commun. Research.2005; 2: 345-396
- [18] Simon Haykin. Communication Systems.4th Edition; Wiley Publications.2004.
- [19] Demir, Alper. Phase noise and timing jitter in oscillators with colored-noise sources. IEEE Transactions on Circuits and Systems I: Fundamental Theory and Applications. Dec 2002; 49(12): 1782-1791.
- [20] V. D. AK, S. Sharmila, Abhishek Kumar, A. K. Bashir, Mamoon Rashid, Sachin Kumar Gupta & Waleed S. Alnumay . novel solution for finding postpartum haemorrhage using fuzzy neural techniques.Neural Computing and Applications (2021) (<https://doi.org/10.1007/s00521-020-05683-z>)
- [21] R. Subha Shini et.al., “ Recurrent Neural Network based Text Summarization Techniques by Word Sequence Generation”.IEEE International Conference on Inventive Computation Technologies (ICICT), 2021, DOI: 10.1109/ICICT50816.2021.9358764



# Bone Cancer Detection Using Feature Extraction with Classification Using K-Nearest Neighbor and Decision Tree Algorithm

Satheesh Kumar, B<sup>a,1</sup> and Sathiyaprasad. B<sup>b</sup>

<sup>a, b</sup> *Research Scholar, Dept of CSE, Annamalai University, India*

**Abstract.** The malignant cells that cannot be controlled from spreading throughout the body is Cancer. Among which the cancer occurs in bone is their type. It is malignant disease occur in bone of human body where their growth cant be controlled from growing. This bone cancer is very critical of all the cancer types since the malignant cells are not identified at their earlier stage and it is the major challenge. Bone cancer is highly common for children and teenagers. For earlier detection of this cancer the correlation of medical imaging has been adapted with image processing and machine learning techniques where maximum accuracy can be obtained similarly even for bone cancer. This paper proposes the detection of bone cancer from the dataset taken from clinical dataset. Here the proposed design comprises of 2 phases in predicting the disorder with higher accuracy. The first stage is extracting the feature of segmented bone image using Gray-Level Co-occurrence Matrix (GLCM) method is applied to extract the features in terms of statistical texture-based and the second phase is classification of extracted feature using K-NN with decision tree algorithm. The simulation results show the enhanced classification results and extracted output with higher accuracy.

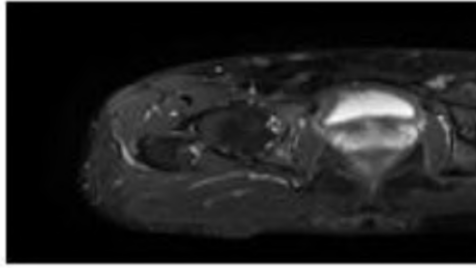
**Keywords:** Cancer, Bone cancer, X-ray, MRI, CT imaging, features, Gray-Level Co-occurrence Matrix (GLCM), K-NN.

## 1. Introduction

A tumour is an abnormal growth of new tissue and that can be formed in any of the organs in our body. There are many different kinds of cancer like lung cancer, brain cancer, and bone cancer. Nowadays bone cancer is considered to be one of the most dangerous and serious cancer in the world, with the smallest survival rate after the diagnosis. There are two types of bone cancer, noncancerous (benign) and cancerous (malignant) [1]. Obtaining an accurate result in bone cancer detection is very important in many imaging application. It mainly helps to plan for the treatment at the earlier stage and for the evaluation of the therapy. The early detection of bone cancer will decrease the mortality rate. To obtain more accurate results, we divided the whole process into three stages, image processing stage, image segmentation, feature extraction, and classification [2].

---

<sup>1</sup>B. Satheesh Kumar, Research Scholar, Dept of CSE, Annamalai University, India.  
E-mail: vbsatheesh30@gmail.com



**Figure1.**MRI Image of the bone with tumour

In the kernel the hyper plane and optimal plane has been divided by the SVM or support vector machine classifier which is discriminative [3]. For feature based classification, KNN classifier is used in obtaining higher similarity and this technique is non-parametric classification [4]. The integration of neural network with fuzzy logic is ANFIS which is together known to be neuro fuzzy classifier. In this classifier, the features of fuzzy design have been obtained through the neural network [5]. The main objective of our proposed method is to have a fast and robust system for detecting the bone cancer in early stage and to obtain a more accurate result than many other existing techniques. Rest of the article has been continued as follows, section 2 discuss the related works which is done in field of bone cancer detection. Section 3 presents the detailed explanation on the proposed work in detecting the bone cancer. Experimental results and their discussion have been discussed in section 4. Final part of paper in section 5 gives the conclusion and the future work for this research.

## **2. Related Works**

Kishore Kumar ReddyC et al. determined the technique in bone cancer detection based on their tumour size and the phases of growing cancer. For segmentation of bone MRI they have used seeded region growing algorithm [6]. KrupaliDMistry et al. explained the method in identifying the bone cancer by combining the feature extraction using clustering algorithm for input MRI images. The tumor cells has been identified after segmentation through mean pixel intensity where it is used in detecting enchondroma bone cancer [7]. MadhuriAvula et.al. Proposed the technique in detecting bone cancer by segmentation of image using k-means clustering algorithm where the tumor has been detected on basis of pixel intensity. The simulation results has been obtained from processing 400 bone MR images [8]. Eftekhar Hossain[9] has proposed an Detection & Classification of Tumor Cells from Bone MR Imagery Using Connected Component Analysis & Neural Network. The bone tumor can be detected by using connected component labeling algorithm. Akash Pandey et al [10] have done a paper on A Survey Paper on Calcaneus Bone Tumor Detection Using different Improved Canny Edge Detector. Here Computer Aided Diagnosing (CAD) is used to analyse Computed Tomography images.

### 3. Research methodology

The research design consists of phase namely pre-processing, feature extraction, training, and testing. Firstly the input image of bone MRI has been processed by filtering and this image which is filtered has segmented. Then this segmented image and the features namely statistical texture-based features of disorders are extracted from segmented image and the texture features are used to predict the category of the bone disorder using machine learning classifiers. The architecture for proposed extraction and classification technique has been given in Figure 2.

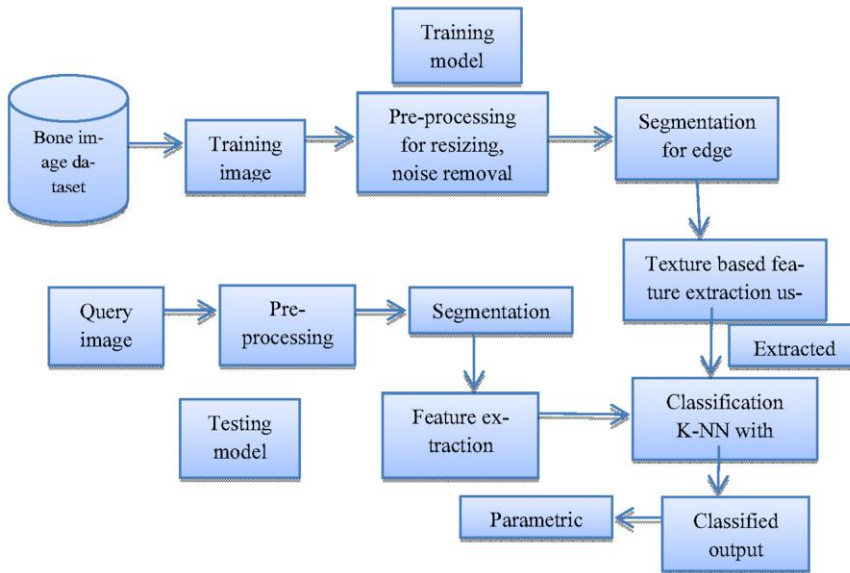


Figure2. Architecture for proposed technique

#### 3.1 Feature extraction using GLCM

Image feature extraction is vital phase of PC based framework. Feature extraction gives certain parameters, based on which PC framework takes choice. After the segmentation is performed on lung area, the features can be acquired from it and the conclusion control can be intended to distinguish nodules in the lung. The whole component which are ascertained from the picture, pass on some data in regards to lung nodule. This data is exceptionally useful in identifying lung nodule as threatening or non-harmful. In this manner the features separated from the CT picture can be utilized as demonstrative pointers. The features that are utilized as a part of this investigation are Texture features utilizing Co- occurrence matrix representation. The GLCM is a second-arrange factual technique for the feature extraction based on texture. To start with, the picture is converted into an l-grey-level image and GLCM is produced through including incidences of intensity pairs among the existing and neighbor pixels for each scale and alignment. The standardized GLCM is computed in the equation beneath:

$$G(i, j) = \frac{N(i, j)}{\sum_{m=0}^{l-1} \sum_{n=0}^{l-1} N(m, n)} \quad (1)$$

Where  $i$  and  $j$  are grey values in the  $l$ - grey level picture.  $N(i, j)$  is the co- occurrence relative recurrence frequency matrix by the equation underneath:

$$N(i, j) = \text{num} (\{(x_1, y_1), (x_2, y_2)\}) \\ |x_2 - x_1 = d \cos \theta, y_2 - y_1 = d \sin \theta, I(x_1, y_1) = i, I(x_2, y_2) = j) \quad (2)$$

Where  $(x_1, y_1)$  and  $(x_2, y_2)$  are pixel positions, and  $I(\cdot)$  is the grey level of the pixel.  $\text{num} \cdot$  means the quantity of the pixel matches that fulfil the comparing conditions. In our work, 15 texture features are ascertained from the comparing GLCM.

### 3.2 Classification using KNN-decision tree

A non-parametric technique which is used for the problem in classification is done through KNN algorithm. The technique points the data by the neighbor for the output labels of classification. KNN is a very simple algorithm that stores all possible class cases, and works to classify new cases based on the functions of the distance (similarity measure), KNN in the field of statistical estimation and pattern recognition. The class is classified by the most votes of its neighbors, with the case being assigned to the most popular class among its  $K$  nearest neighbors measured by the function of the distance, if the value of  $k$  is one, the class is simply assigned to the nearest neighbor class, and classification is easy.  $K$ -nearest neighbor algorithm steps:

1. Search for the nearest neighbor numbers that is denoted as  $K$ .
2. Calculate the training sample and query image distance.
3. On basis of minimum distance, it has been collected and evaluated by nearest neighbors.
4. From nearest neighbor, class  $Y$  has been collected.
5. As the number of prediction class is given for query image, the majority of nearest neighbor has been used.

### 3.3 Decision tree

The training-set feature extracted images are chosen to become familiar with the feature behaviour related to parameters as well to figure out data gaining for various feature sets. Features with high data gaining are chosen as Decision tree features.

The pseudo code for Decision-Tree algorithm is as follows:

- i. The input characteristic is given as the optimal feature by their root node of the tree.
- ii. The dataset has been classified for training into sub-classes.
- iii. The classified sub class has been carried out for every subclass where the data which has same value as input characteristic.
- iv. After all the above steps, step 1,2,3 has been iterated for every subclass until the node part in each branch in tree has been identified. Since this decision tree is used for classification, whole training data for input has been considered to be

root. The extreme evaluation of decision tree. When this is maximum, there will be problem of over-fitting. And this represented by size with the standard of nodes of the tree. When every node is used to be in classification of binary pattern, then their size has been maximum as  $2d+1-1$ , here  $d$  is denoted as the depth of the tree.

*Steps for KNN-DA*

**Step 1:** Choose K number of samples from the training set to generate initial population (P1).

**Step 2:** Calculate the distance between training sets in each chromosome and testing samples, as fitness value.

**Step 3:** Choose the chromosome with highest fitness value store it as Global maximum (Gmax), for iteration value 1 to L

- a. Perform reproduction
- b. Apply the crossover operator.
- c. Perform mutation and get the new population. (P2)
- d. Calculate the local maximum (Lmax).
- e. If  $G_{max} < L_{max}$  then Assign  $G_{max} = L_{max}$ ;  $P1 = P2$ ;
- f. Repeat

**Step 4:** Output – the chromosome which obtains Gmax has the optimum K-neighbours and the corresponding labels are the classification results.

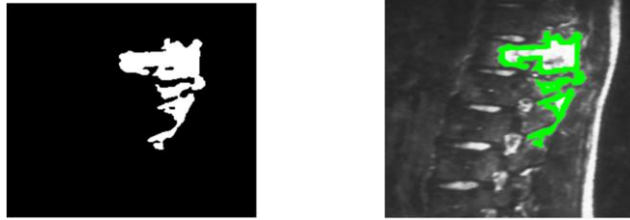
#### 4 Performance analysis

Contradicting of our algorithm is done with the existing algorithms in terms of various parametric metrics like accuracy, sensitivity specificity, f1 score, recall are chosen to evaluate the classification performance of the KNN classifier.



**Figure 3.** (a) Training input data (b) Testing input data

Figure3.(a) and (b) show that known data added with previously known decision values has been fed to classifiers. Training data classifies unknown images. A single set of 700 brain MRI images for training and also, a set of 60 images for testing are used.

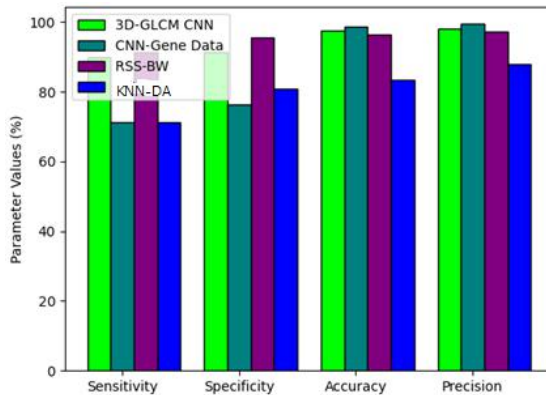


**Figure. 4.** (a) Extracted tumour from input image **Figure.4.** (b)-Detected tumour

Figure 4.(a) and (b) shows the extracted tumour feature and detected region of tumor from taken input bone image dataset. Table-1 gives overall performance comparison analysis statistically.

**Table 1.** Overall Performance Analysis

Method	Sensitivity (%)	Specificity (%)	Accuracy (%)	Precision (%)
3D-GLCM CNN	90.00	71.36	91.37	71.20
CNN with gene data	91.40	96.06	95.69	81.03
RSS-BW	97.52	98.60	96.38	83.45
KNN-decision tree	98.20	99.56	97.27	87.83



**Figure 5.** Overall comparative analysis of existing and proposed algorithm

The figure 5 compares the values achieved for the parameters. X axis and Y axis shows parameters considered for analysis and parameter values obtained in percentage respectively. The proposed algorithm achieves 98.2% of sensitivity, 99.56% of specificity, 97.27% of accuracy and 87.83% of precision. Finally, when compared to prevailing 3D-GLCM CNN, CNN with gene data, and RSS-BW proposed KNN-DA algorithm, shows better results.

## 5. Conclusion

The proposed technique has been done for detecting the tumor in bone by the extraction of the features and classification. This technique is used for identifying the presence and non-presence of tumor in input MRI which has been classified as benign or malignant class after this detection. Bone cancer cause unnatural growth of cells as to grow out of control in bone, which growth rather destroys normal bone tissue and start to spread in other body parts. Detecting cancer tissue is a vital issue for pathologists to know and recognize potential lesion tissue. This paper proposes the feature extraction of bone tumour GLCM and classification using KNN-DA. The accuracy obtained by the proposed technique is enhanced and improved. The aim of this work is to implement the design in differentiating malignant bone cancer from benign cells and this gives effects on clinical analysis. The future work can be developed with classification for various types of bone tumor like chondroma, Ewing sarcoma, and chondrosarcoma etc.

## References

- [1] Yang, A., Yang, X., Wu, W., Liu, H., & Zhuan, Y. Research on feature extraction of tumor image based on convolutional neural network, 7, 24204-24213 (2019).
- [2] Goswami, S., & Bhaiya, L. K. P. A hybrid neuro-fuzzy approach for brain abnormality detection using GLCM based feature extraction, In 2013 International Conference on Emerging Trends in Communication, Control, Signal Processing and Computing Applications (C2SPCA) 1-7 (2013).
- [3] Chen, X., Li, J., Zhang, Y., Lu, Y., & Liu, S. Automatic feature extraction in X-ray image based on deep learning approach for determination of bone age, Future Generation Computer Systems, 110, 795-801 (2020).
- [4] Nakajima, K., Nakajima, Y., Horikoshi, H., Ueno, M., Wakabayashi, H., Shiga, T., & Edenbrandt, L., Enhanced diagnostic accuracy for quantitative bone scan using an artificial neural network system, a Japanese multi-center database project. EJNMMI research, 3, 1-9 (2013).
- [5] Shakeel, P. M., Burhanuddin, M. A., & Desa, M. I. Automatic lung cancer detection from CT image using improved deep neural network and ensemble classifier, Neural Computing and Applications, 1-14 (2020).
- [6] Reddy, C. K. K., Anisha, P. R., & Raju, G. V. S. A novel approach for detecting the tumor size and bone cancer stage using region growing algorithm, In 2015 International Conference on Computational Intelligence and Communication Networks (CICN) 228-233 (2015).
- [7] Mistry, K. D., & Talati, B. J. Integrated approach for bone tumor detection from mri scan imagery, In 2016 International Conference on Signal and Information Processing (ICONSIP) 1-5 (2016).
- [8] Avula M, Lakkakula N.P, and Raja M.P. Bone cancer detection from mri scan imagery using mean pixel intensity, in Modelling Symposium (AMS), 2014 8th Asia. IEEE, 141-146 (2014).
- [9] Hossain .E and Rahaman.M.A. Detection & Classification of Tumor Cells from Bone MR Imagery Using Connected Component Analysis & Neural Network, 2018; International Conference on Advancement in Electrical and Electronic Engineering (ICAEEE) 1-4 (2018).
- [10] Pandey and S. K. Shrivastava. A Survey Paper on Calcaneus Bone Tumor Detection Using different Improved Canny Edge Detector, 2018 IEEE international conference on system, computation, automation and networking (icscan) 1-5 (2018).

# Implementation of IoT in Workplace Monitoring and Safety Systems

C.Annadurai<sup>a,1</sup>, I.Nelson<sup>b</sup>, X.N.Ranald Nivethan<sup>b</sup>, SurajVinod<sup>b</sup>, M. Senthil Kumar<sup>b</sup>  
<sup>a,1,b</sup>*Dept of ECE, SSN College of Engineering, Chennai, India*

**Abstract:** The continuous and rapid development in facilities in the workplace eventually calls for safety of the workplace premises as well as improved monitoring system. For instance, an intruder alert will be sent even if a client enters the premises. To eradicate this issue, an alert notification has to be sent only when required i.e., during an intruder detection or mishap detection. The data is collected by Raspberry Pi using the sensors interfaced to it. By employing the usage of IoT, data received from the sensors are sent to an IoT platform from where the information is passed as a notification through an email. The detected face from the video recorded by PiCam is sent to a local server using socket programming and the Face recognition is performed in the local server using Haar cascade and LBPH algorithm in Open CV. In case of an intruder detection, an e-mail notification is sent to the user. Similarly, when an accident or disaster is detected such as a fire accident or air pollution, an alert notification is sent to the user through an e-mail.

**Keywords:** Internet of Things, Facial Recognition, Security System, Machine Learning.

## 1. Introduction

The need for safety and security is of utmost importance at present than ever before especially in a workplace or an industry. The word safety does not confine its concern only with the physical possessions of an organization but also an integrated protection. The rising need for safety has led to the emergence of various devices that serve the desired purpose. Initially products were designed to serve a single purpose and the majority of the devices were designed only to ensure the security of a workplace or an industry or even houses[2-4]. The vastly used product was the surveillance camera that helped people monitor their premises without the need for the presence of a human in place. This still remains as the largely preferred device for security but as far as the entirety of safety is concerned, an integrated safety system is the most suitable one. An integrated safety system helps in efficiently safeguarding the workplace in all areas possible. Recently, implementation of IoT in safety systems have been able to provide

---

<sup>1</sup>Anna DuraiC ,Dept of ECE, SSN college of Engineering, Chennai ,India  
E-mail: annadurai@ssn.edu.in



the user an easier access in monitoring their premises [1,5,6]. Although it has been helpful in many aspects there are still areas that can be further improved making the safety system even better. The system proposed here makes use of Picam and sensors such as smoke sensor and air quality sensor. This helps the user to know the state of their premises that includes features like intruder alert, smoke detection and air pollution detection.

## 2. Proposed System

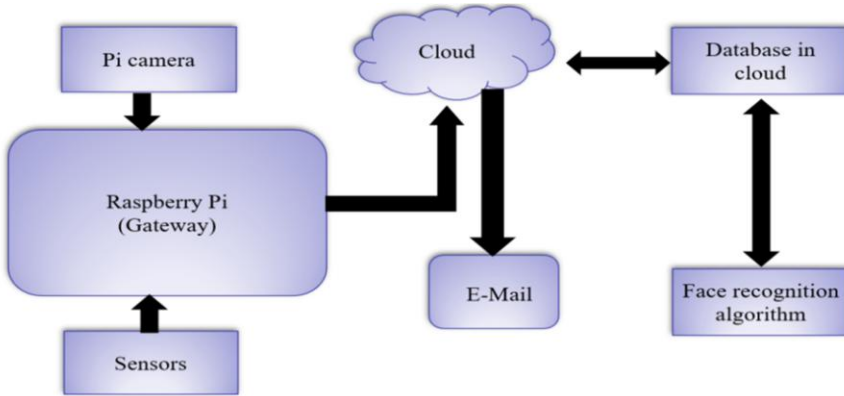


Figure 1. Block diagram of proposed system

## 3. Face Detection Algorithm

### 3.1 Haar cascade

Object Detection using Haar feature-based cascade classifiers is a constructive object detection method proposed by Paul Viola and Michael Jones in their paper, "Rapid Object Detection using a Boosted Cascade of Simple Features" in 2001. Based on positive and negative images, the cascade function will be trained. It is then used to identify objects in other images. At first, the algorithm should be provided with a lot of positive images (images of faces) and negative images (images without faces) to train the classifier. Based on the training, features are extracted from it. The sum of pixels of the white rectangle from the pixel sums is subtracted from black rectangle to obtain a feature. A variety of sizes and locations of each kernel are used to evaluate and capture lots of features. Using the integral image, the sum of pixels under black and white rectangle can be calculated for obtaining the features. The catch here is that, among all these features calculated, most of them are irrelevant. So, among the available features, the best features are selected using Adaboost algorithm.

All available features are applied on training images. One feature that strongly separates the positive images and negative images, alone is selected. Among the selected features, there will be errors and misclassifications as well. So, a feature which has the least error rate which classifies whether there is a face or no face is present is selected for use. By taking weighted sum of the classifiers which were selected from the previous iterations, we form a strong classifier. The classifier selected in previous stage

alone cannot detect the images but by taking weighted average they can. Most of the pictures given does not contain a face. By using a check method, classify if a window consists of facial region or not and discard it in first time processing of the window and do not process it further. The rest of the region consists of facial region which can be focussed on instead of the entire image using classifiers in cascade. All the features selected are not applied in a single window, instead they are grouped into various stages. If a window does not successfully pass through one stage, it is discarded and it is not processed in further layers. If the same window passes in one stage then the next stage of features is applied. If the same window passes through all stages, then it is considered as a face region.

### *3.2 Local binary pattern histogram(Lbph)*

Local binary pattern designates a particular pixel of an image by using the binary number that we got from the threshold levels of the neighbouring pixels of the current pixel. This strategy is very simple as well as efficient. The local binary pattern uses four parameters for thresholding the neighbourhood pixels, they are: radius, neighbours, grid x and grid y. The radius is used to represent the area around the chosen pixel and subsequently used to construct the binary pattern. The neighbours is the count of the sample points required to build the binary pattern corresponding to the radius chosen. When the count of the sample points obtained is more, then the computational resources needed is also higher. The grid x parameter is used to find the number of cells present in the horizontal direction. The feature vector's dimension depends on this parameter. If the dimension is more, the grid is also more fine. The grid y parameter is used to find the number of cells present in the vertical direction. The feature vector's dimension increases as the grid becomes more fine. The algorithm is trained using the data of the people who will be recognized using their face images. Each person's image is given an ID(identification) which the algorithm uses to give output corresponding to an input image. All images of a particular person are given the same ID. By using the sliding window algorithm that takes neighbours and radius parameters into account, the algorithm creates an intermediate image that highlights the facial characters and represents the given image in a better way. The image given is converted in grayscale and a portion of this image as a window of 3 x 3 pixels is obtained. This is represented in a matrix that has intensity of each pixels. By using the value that is middle element in the matrix as threshold, the neighbours are given a binary value depending on whether they are greater than or less than the threshold. This matrix is assigned a new binary value by concatenating each binary value from each position. The value obtained is then converted into a decimal value and set to the central value of the matrix which is a new pixel value from the original image. Thus, the obtained image represents the characteristics of the original image in a better way.

Grid X and grid Y parameters are used to divide the image into multiple grids each represented as a histogram containing 256 positions representing the occurrences of each pixel intensity. A final histogram representing the characteristics of the original image is obtained by concatenating the individual histograms. A new image is captured and the same steps above are performed for Face recognition. Now the obtained histograms are compared with existing histograms using Euclidean distance. Therefore the output of the algorithm is the ID of the most matching histogram.

#### 4. Result

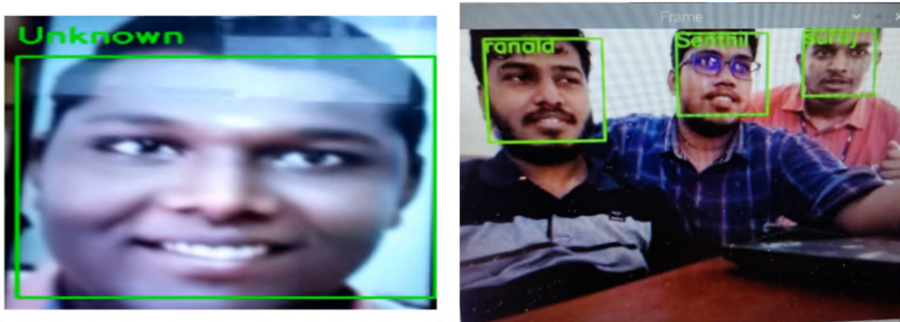


Figure 2. Output with known and unknown persons

#### 5. Conclusion

The proposed system is designed in such a way that it integrates multiple features such as surveillance, disaster and accident management into a single system. The compactness and simplicity of the system makes it easy to use for the user. As far as disaster and accident management is concerned, the system sends an alert notification in case of any mishap which helps the user be able to be aware of the status of the premises even when not present. The surveillance system employed is made efficient by using smart recording feature and by avoiding unnecessary intruder alerts. The unnecessary intruder alerts is eliminated by sending an e-mail to the user and he decides if the person is an intruder or not. Thus, the proposed system is more useful and easy to operate. This also increases the comfort of the user.

#### References

- [1] Sonali P. Gulve, Suchitra A. Khoje, PrajaktaPardeshi, Implementation of IoT-based Smart Video Surveillance System, Conference: Computational Intelligence in Data Mining, At: Singapore Vol: 556, 2017
- [2] Sun, Yi, Xiaogang Wang, and Xiaoou Tang, Hybrid Deep Learning for Face Verification IEEE Transactions on Pattern Analysis and Machine Intelligence Vol 38, No 10 2013
- [3] R. Chellappa, C.L. Wilson and S. Sirohey, Human and machine recognition of faces: A survey , Proc. IEEE , Vol 83, pp. 705-740, 1995
- [4] Paul Viola, Michael Jones, Rapid Object Detection using a Boosted Cascade of Simple Features, Accepted Conference on Computer Vision and Pattern Recognition 2001.
- [5] Ishita Gupta, Mrs.VarshaPatil, ChaitaliKadam, ShreyaDumbre, Face detection and Recognition using Raspberry pi", IEEE International WIE Conference 185 on Electrical and Computer Engineering (WIECON-ECE), pages 83–86. IEEE, dec 2016
- [6] PravinKumar.S, Bhuvanewari Balachander, Fast and Cost Efficient Face Detection System with CNN Using Raspberry PI , International Journal of Engineering and Advanced Technology (IJEAT) ISSN: 2249 – 8958, Volume-8 Issue-6, August, 2019 .
- [7] V.D.Ambeth Kumar et.al, , "FACIAL RECOGNITION SYSTEM FOR SUSPECT IDENTIFICATION USING A SURVEILLANCE CAMERA", Pattern Recognition and Image Analysis (Springer), Volume 28, Issue 3, pp 410–420, 2018. (DOI: 10.1134/S1054661818030136)
- [8] V.D.Ambeth Kumar (2017), "Efficient Routing for Low Rate Wireless Network a Novel Approach", International Journal of Image Mining, Vol. 2, Nos. 3/4, 2017, 2017.

# IoT Based Smart Energy Meter System Using Machine Learning

Nelson. I<sup>a,1</sup>, Annadurai. C<sup>b</sup>, Ramya. E<sup>b</sup>, Shivani. R<sup>b</sup> and Mathusathana. V<sup>b</sup>

<sup>a,1</sup>Associate Professor, Dept of ECE, SSN College of Engineering, Chennai, India

<sup>b</sup>Associate Professor, Dept of ECE, SSN College of Engineering, Chennai, India

<sup>b</sup>UG Scholar, Dept of ECE, SSN College of Engineering, Chennai, India

**Abstract.** India is the world's third largest producer and third largest consumer of electricity[1]. The per person energy consumption in India in 2019 is 1181 kWh .With increasing demand and value for energy, it has become tedious to keep track of consumption of energy units. Smart Meters can override these difficulties by providing a more appropriate solution which includes accurate billing, better information on energy consumption thus leading to better utilization. These Smart energy meters are beneficial to both the consumer and the supplier. They provide a more efficient solution in determining tariffs for the latter. Internet of Things is an emerging technology and IoT based devices have revolutionized the field of electronics and IT. The proposed project is an IoT Based Smart Energy meter system developed to efficiently manage the energy consumption in households by avoiding wastage ,to provide accurate information to small scale users and to avoid manual meter reading and automate bill data entry process.

**Keywords.** Internet of Things, Smart Energy Meter System, Thingspeak, Machine Learning.

## 1. Introduction

The internet of things (IoT) is a network of interconnected smart devices enabling data transfer i.e. objects that can be identified uniquely and have the ability to collect and transfer data over a network without manual assistance or intervention. These devices interact within themselves as well as the surroundings and act decisively based on various conditions. India's dependency on energy imports can be limited by promoting energy conservation. This calls for a system built keeping the goal in mind and to analyze and thereby control energy consumption .Thus, an integrated IoT smart meter system is an appropriate solution.

## 2. Proposed System

The proposed project is an IoT enabled device which sends meter readings to the server at a fixed time interval using Node MCU. The system features an alerting system,

---

<sup>1</sup>Nelson.I, Associate Professor, Dept of ECE, SSN College of Engineering, Chennai, India.  
E mail: nelson@gmail.com

a home automation unit, a forecasting system and an android application. The proposed project aims to pave the way for efficient resource utilization.

### 3. Architecture of the system

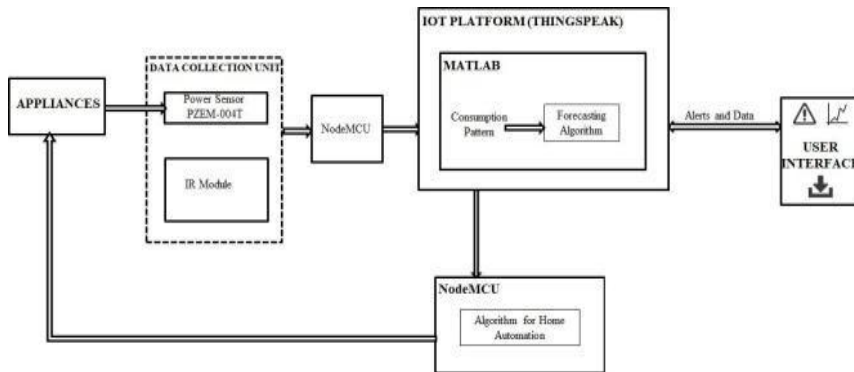


Figure 1. System Block Diagram

The data collection unit comprises the power sensor which is used to measure consumption and a module comprising IR Sensors which we use for the home automation system. Firstly, user's consumption acquired by the power sensor is sent to the NodeMCU. The NodeMCU is used to send the data to the cloud. The consumption pattern is monitored and when it surpasses the thresholds, alerts are sent to the user interface. The consumption pattern is displayed in the form of graphs and significant figures as texts for the user's review. The consumption pattern is also provided as an input for the Forecasting algorithm and the NodeMCU used for the home automation system. The IR Module is utilized for the home automation feature. A pair of IR Sensors are installed in the entrance of each room. The order in which the sensors sense human presence is noted for determining whether the user's entering or leaving the room. This information is sent to the nodeMCU which in turn sends it to the cloud. These values along with the consumption data are sent to the nodeMCU connected to the appliances.

### 4. Features of the system

#### 4.1 Home Automation

The purpose of the home automation system is to automate the operation of appliances in order to keep the consumption below the threshold. This feature can function in two modes -Manual mode and Autonomous mode. The algorithm used for home automation takes in the user's consumption, the operational mode of the system, consumption limit for an hour and the presence of an individual in a particular room. The consumption for an hour is estimated from the consumption limit for two months specified by the user. The algorithm checks whether the user's consumption has

exceeded the threshold estimated. If it did exceed, the system sends an alert to the user and then proceeds to check the operational mode of the system. If the system is in autonomous mode, it checks for the presence of the individual in a room and decides whether to turn the appliances ON/OFF. If the system is in the manual mode, the user can control which appliances need to be turned ON/OFF as per his/her requirement.

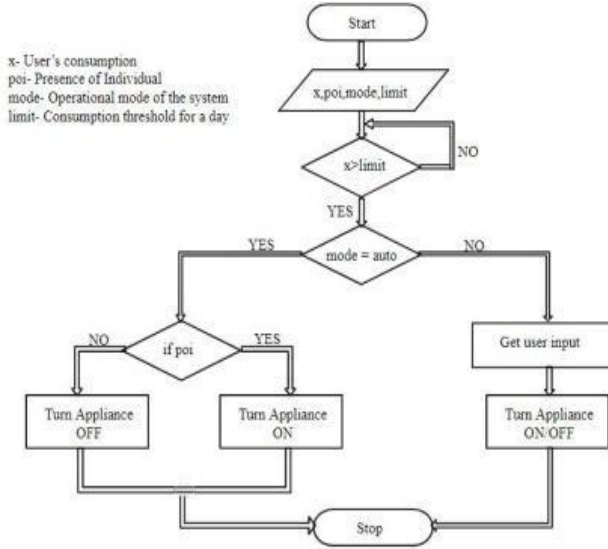


Figure 2. Flowchart of Home Automation algorithm

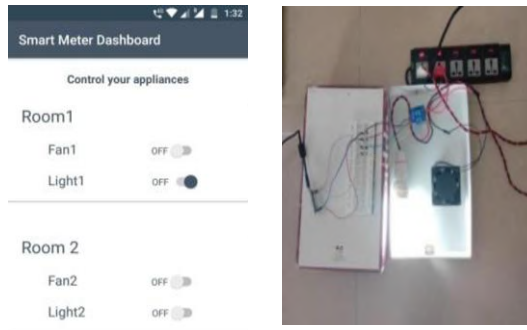


Figure 3. Manual Mode

#### 4.2 Alerting System

The system alerts the user when hourly consumption exceeds the hourly threshold calculated and when the overall consumption exceeds 100 units, 200 units and 500 units. The TNEB tariff system has various schemes having different costs per unit of consumption and fixed charges. The first 100 units are of no charge in every scheme.

When the user's overall consumption exceeds 100 units and is within 200 units, the cost per unit is 1.5 Rs. But when the consumption exceeds 200 units and is within 500 units, for the same 100 units the cost per unit is 2 Rs. This amount can magnify when we consider a bigger scale. Hence by alerting the user when their overall consumption exceeds 100 units, 200 units and 500 units, the system stresses that every unit of consumption plays a vital role.

#### 4.3 Forecasting System

The purpose of energy forecasting is to predict future energy consumption and thereby effective energy management. The proposed system incorporates a forecasting model which utilizes the decision tree classifier and predicts energy consumption given a bounded historical data of the consumer and other variables. The variables used in forecasting are Holidays (to distinguish working days and holidays), Past energy consumption, Weather, Temperature of a particular day. With the help of Forecasting, the future consumption of users can be predicted and helps the users plan resources accordingly.

#### 4.4 Android Application



Figure 4. User Interface

The Android Application takes care of retrieving and displaying data to the user and also takes data to the cloud from the user. The purpose of the interface is to make user's interaction simple and efficient. It acts as a medium for two-way communication in cases like controlling appliances, getting consumption threshold as inputs and for displaying consumption patterns and billing details. Consumption data is presented in the form of graphs for better understanding and interpretability.

### 5. Conclusion

Thus, using emerging technologies such as IoT can bring a tremendous amount of change in the utilities sector leading to efficient energy management by providing accurate and reliable information. Hence Smart energy meters paves way for efficient

resource utilization and uniform distribution in a systematic way which in turn ultimately leads to energy conservation – an urgent necessity.

## References

- [1] Arya College, August 2018 Solar Energy Retrieved from: <https://aryacollege.org/our-blog/2018/08/>
- [2] BibekKanti Barman, Shiv NathYadav, Shivam Kumar, SadhanGope. IOT Based Smart Energy Meter for Efficient Energy Utilization in Smart Grid, 2018 2nd International Conference on Power, Energy and Environment:Towards Smart Technology (ICEPE), 2018
- [3] Chaudhari S, Rathod.P, A. Shaikh, D. Vora and J. Ahir. Smart energy meter using Arduino and GSM, 2017 International Conference on Trends in Electronics and Informatics (ICEI), Tirunelveli, 2017, pp. 598-601.
- [4] Salman siddiq S , S. Reshma , K. Anuja , P. Priyanka , Ch. Karunapravaha Smart Electricity Meter using Wi-Fi, International Journal of Research in Advent Technology, Vol.5, No.3, March 2017 E-ISSN: 2321-9637.
- [5] Swamy M, Pravallika R.Design and implementation of smart energy meter, 2017 International Journal of Innovative Research in Computer and Communication Engineering, Vol. 5, Issue 8, August 2017,ISSN: 2320-9801.
- [6] R.Kappagantu , S. Senn , M.Mahesh , S.A.Daniel “Smart grid implementation in India – A case study of Puducherry pilot project”International Journal of Engineering, Science and Technology Vol. 7, No. 3, 2015, pp. 94-101
- [7] Hambali M, Akinyemi A, Oladunjoye J, Yusuf N,(2016): Electric Power Load Forecast Using Decision Tree Algorithms. Computing, Information Systems, Development Informatics & Allied Research Journal. Vol 7 No 4. Pp 29-42.
- [8] Barua A.M, Goswami P.K ,Analysis of Household Electricity Consumption Using Smart Meter Data, International Research Journal of Engineering and Technology Vol. 7, Issue: 8, 2020.
- [9] Shukla.R ,Vidhwani.M Prof. V.R. Ghule, Electricity Theft Detection Using Machine Learning ,International Journal of Advance Scientific Research and Engineering Trends,2019-20,Volume 4,ISSN (Online) 2456-0774.
- [10] Ambeth Kumar V.D, Precautionary measures for accidents due to mobile phone using IOT, Clinical eHealth, Volume 1, Issue 1, March 2018, Pages 30-35.
- [11] Nanagasabapathy.K et.al.,Validation system using smartphone luminescence, IEEE International Conference on Intelligent Computing, Instrumentation and Control Technologies (ICICT), Pages: 235 – 239, 6-7 July 2017, Kannur, India
- [12] Ambeth Kumar V.D; V. D. Ashok Kumar; H. Divakar; R. Gokul, Cloud enabled media streaming using Amazon Web Services, IEEE International Conference on Smart Technologies and Management for Computing, Communication, Controls, Energy and Materials (ICSTM), Pages: 195 – 198, 2-4 Aug. 2017, Vel Tech University, Chennai, India (DOI: 10.1109/icstm.2017.8089150)
- [13] Aravindh .Bet.al, .A novel graphical authentication system for secure banking systems, IEEE International Conference on Smart Technologies and Management for Computing, Communication, Controls, Energy and Materials (ICSTM), Pages: 177 – 183, 2-4 Aug. 2017, Vel Tech University, Chennai, India .
- [14] Ambeth Kumar V.D et.al, (2016), An Efficient Security System for Data base Management from Illegal Access, IEEE International Conference on Wireless Communications, Signal Processing and Networking (WiSPNET), SSN Engineering College, Chennai, India, 23-25 March, 2016
- [15] Ramya,T et.al.,(2014) Personalized authentication procedure for restricted web service access in mobile phones, Applications of Digital Information and Web Technologies (ICADIWT), 2014, Page(s):69 - 74, Bangalore, India (ISBN:978-1-4799-2258-1)
- [16] Ambeth Kumar V.D,Saranya,G ,Elangovan.D, RahulChiranjeevi.V, Ashok Kumar V.D, IOT Based Smart Museum Using Wearable Device, Lecture Notes in Networks and Systems, Vol.55, pp: 33-42, 2018
- [17] Ambeth Kumar V.D et.al, (2016).An Efficient Security System for Data base Management from Illegal Access, IEEE International Conference on Wireless Communications, Signal Processing and Networking (WiSPNET), SSN Engineering College, Chennai, India, 23-25 March, 2016.



# Personalized CAPTCHA Using Cognitive Cryptography

Radhika<sup>a,1</sup>, Somasundaram.S K<sup>b</sup> and Sivakumar.P<sup>b</sup>

<sup>a,1</sup> PG Scholar, Dept of IT, PSG College of Technology, Coimbatore, India

<sup>b</sup> Assistant Professor, Dept of IT, PSG College of Technology, Coimbatore, India

**Abstract.** Cognitive Cryptography is used to improve personal verification process using the individual's characteristics. The personal information contained can be biometrics because it is the unique information that identifies the owner. In advanced cryptographic protocol oriented for authentication of user, there is a possibility of using personal characteristics and perception abilities are required to create a new authentication procedure. This paper presents a new approach for creation of advanced multilevel user authentication protocol by using Image grid CAPTCHA codes. Here the user needs the special skills or knowledge while verifying, this is because of cognitive CAPTCHA's. Instead of generating some random numbers or text while authentication procedure these CAPTCHA's can be used. In multilevel authentication code the user verification can be realized in several iterations, in which the user attention can be oriented on different visual elements, region of interest or semantic content. This cognitive code will able to identify the recognition abilities of the user. Cognitive codes are having high security feature similar to traditional CAPTCHA's because of understanding or recognizing the blurred or distorted patterns and also requires background knowledge to experience the connection with evaluated patterns. This feature guarantees the high level of security and allows to get succeeded in authentication process because the user possess specific skill that or not available for computers or answering systems. The traditional authentication protocols are to be involved with human mental capability is the vital idea of the proposed solution.

**Keywords.** Cognitive Cryptography, Multi-level authentication, CAPTCHA codes, human mental capability.

## 1. Introduction

Personal cryptography refers to classifying information in the protocols of data sharing by means of labeling information conducted in accordance to the personal features of the secret holders. Every part of information is subjected to the labeling process executed at the stage of shadow allocation and the identification process conducted at the stage of information reproduction. Based on the biometric features contained in personal information, it is possible to specify clearly that person and whose biometric allocate personal features to right person based on analysis of DNA code, fingerprint, facial, eye, palm, speech, walking manner and characteristics feature of human body organ.

---

<sup>a,1</sup>Radhika, PG Scholar, Dept of IT, PSG College of Technology, Coimbatore, Tamil Nadu, India.  
Email: s.radhika.meenakshi@gmail.com

The personalized cryptography is used to enhance the security while it is being compared to traditional cryptography and which is the main objective of cognitive cryptography. The difference between cryptography and cognitive cryptography is, Cryptography encryption does not depend on cryptographer's personal information or semantic meaning of information. Cognitive Cryptography is based on cryptographers personal data, semantic meaning of information and context of procedure. The semantic information of information or resources is based upon on UBIAS and E-UBIAS cognitive system. The cognitive systems may also use semantic data, by analysing it from the information that is to be secured. It produces a semantic description of the examined information. And then use this description to apply a specific cryptographic procedure aimed at encrypting this information, secretly sharing it or encrypting it.

## **2. Related Works**

A new computational model called semantic data evaluation for cryptographic applications. The semantic meaning of encrypted messages is taken into account. Cryptography procedures and Cognitive approaches are combined to derive new computational model. All such techniques are related to crypto-biometrics techniques and also cognitive and semantic procedures [1]. [2] Introduces a new set of CAPTCHA codes called CATCHA. These codes are very popular and it is used in many applications or website for providing remote services of data accessing Authentication using CAPTCHA ensures that the responses comes from the human or bot. It guarantees confidentiality of data using personal and perceptual characteristics

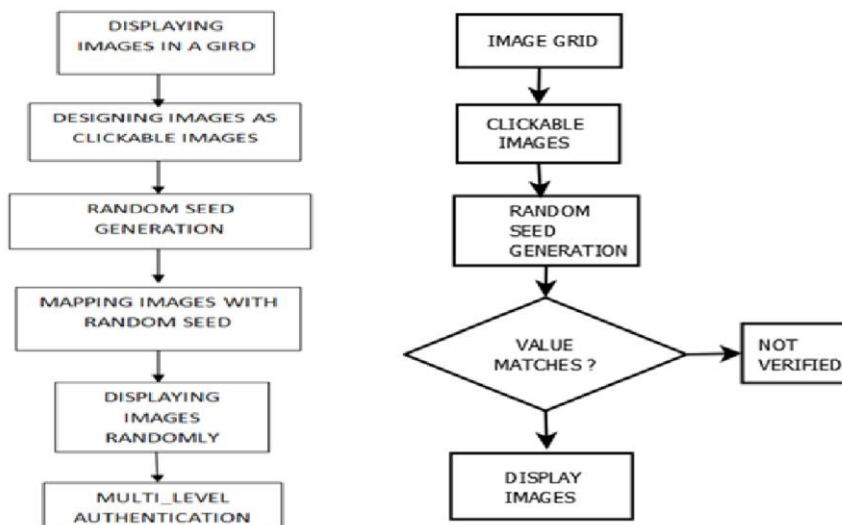
Multi stages of verification can be done using several iterations. These features guarantee the appropriate level of security and allow to successfully passing verification procedure only for high-qualified users, who possess specific and expertise information, which are not available for computer or answering systems[3].

[4] Introduces a algorithm for maintaining usability in optimizer. The Distortion methods used are: 1) Crowding characters together, 2) random arcs, 3) overlapping characters, 4) Random connected line. Usability is based on following parameters such as learning, efficiency, errors, memorizing and satisfaction [5]. CAPTCHA'S are generated based on face images. The distorted face images will be given, we need to identify the face correctly while there will be non-human images also. And if all responses are correct then test is solved [6].

Development of two new face recognition CAPTCHAS using Farett-Gender and Farett-Gender& Age. The security analysis of both procedures is performed [7]. Process of information sharing usually refers to classified information. The personal verification method is used to reproduce the information[8]. In [9], if users biometric are compromised, it might be impossible or highly difficult to replace it in a particular system. It can be achieved through, combining multiple biometric traits, selecting different feature set from some source of biometric. A new model is designed where a keyword is selected based on lexical chains. The semantic feature of the keyword is used. Trustworthiness is detected using registration stage and detection stage.

### 3. Proposed Methodologies

Cognitive Cryptography is combination of cognitive skills with traditional cryptography. In traditional cryptography authentication can be done through CAPTCHA's where recognition abilities and noisy patterns makes the system more secure for authentication. Based on iterations users skill can be recognized and ensures confidentiality. The overview of the project is given as a flowchart in figure 1.



**Figure 1.** Overall process to be carried out

**Modules Description:** This project creates a new set of authentication codes based on are verified in multiple stages of verification. Workflow or overall module flow is explained using the figure 2.

#### 3.1 Dataset Description

Dataset consist of images. Images in folders are named in numbers and folders are named using user id. The dataset is taken as sample images. Initially the dataset will have 6 images named as 1.jpg to 6.jpg, three folders named a, b and c. Each folder has 6 images named as 1.jpg to 6.jpg.

#### 3.2 CAPTCHA Generation

Image based CAPTCHA'S are generated as grid, for example I created 4 images in a 2\*2 grid. Then images are created as clickable images using Tkinter library. Buttons are created using Tkinter, and are displayed as grid. While displaying images, selection of images is done using random function. Now this list value is separately stored in a variable and it is being compared with the filename. If the filename and variable value matches then function will be called and images will be verified. Multi-level Authentication: Here authentication is done using comparison of values. If first iteration is verified successfully, then another set of verification process is initiated.

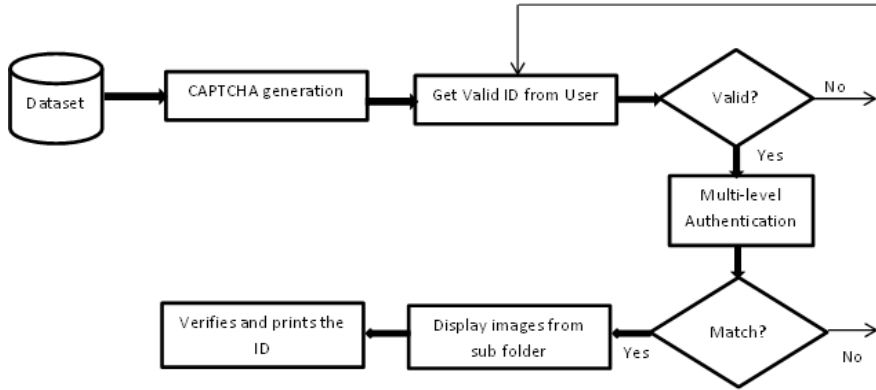


Figure 2. System Architecture

### 3.3 CAPTCHA Generation

**Grid Formation:** Initially, in grid formation using matplotlib grid axes is created. With the help of axesgrid module grid can be created. Then using for loop grid axes of image is displayed. The images are displayed with the help of file directory with image open command. **Clickable Images:** Tkinter module is used to display the image as clickable image. The title for root window can also be declared using root. title() command. **Random Seed Generation:** Random can be imported for using random seed function. For example, if the random seed value that is stored is 3 then it will be printed as “verified” else “Not verified”. **Selecting Images Randomly From Subfolder:** The images from subfolders are to be displayed for first iteration. For example, if we try to click the correct image then it’s based on user-id another set of iteration will happen.

### 3.4 Validation of CAPTCHA

Validation of CAPTCHA can be done using the def() function. The function can be called in the button command. The button command is used to have an argument command which is used to call the def() function. This is used for validation of images.

### 3.5 Multi-Level Authentication

Multi-level authentication can be done after the first iteration. The master window is the main window which is used to display the first iteration of images. The second set of images can be titled as multi-level authentication and it is used to display the images randomly. For verification, we can compare the value with the id or subfolder.

## 4. Result Analysis

Initially, a random list is created and is displayed in the command console. The random lists are mapped with string variables for displaying the images accordingly to the list generated. Then for multi-level authentication, based on the id of the user another set of random list is taken and are mapped with string variables. Finally, multilevel

authentication is completely processed and this can be shown in figure 3. Here initially, a random list is generated and got user-ids from the user then verifying in first iteration.



Figure 3. Multi-level authentication

## 5. Conclusion and Future Work

Thus, the personalized CAPTCHA is created for single user. It is also validated based on his/her special skills. Normally CAPTCHA'S is created for group of user, to overcome this personalized CAPTCHA is introduced. To ensure confidentiality verification is done at each step. For authentication, multi stages verification or set of iterations is used. Cognitive Cryptography follows traditional method and also provides enhanced security for the system. This project can be implemented in banking system for authentication or verification of a user while he or she is trying to login to the application. User's knowledge is being tested in all the iteration so that bypassing the credentials will be impossible. In future work, protecting dataset and the scalability issue of maintaining such a large image based dataset have to be addressed as well.

## References

- [1] Marek R. Ogiela, Lidia Ogiela. On Using Cognitive models in Cryptography. 2016 IEEE 30th International Conference on Advanced Information Networking and Applications.
- [2] Marek R. Ogiela, Lidia Ogiela. Multi-level Authentication Protocols Using Scientific Expertise Approach. Springer Nature Switzerland AG 2020 L. Barolli et al. (Eds.): AINA 2019, AISC 926, pp. 176–180, 2020.
- [3] Suliman A. Alsuhibany. Evaluating the Usability of Optimizing Text-based CAPTCHA Generation. (IJACSA) International Journal of Advanced Computer Science and Applications, Vol. 7, No. 8, 2016.
- [4] DonghuiHu, JuanZhang, XuegangHu, LianWang, WenjieMiao, ZhengfengHou. Textsource trustworthiness detection based on cognitive hash.
- [5] Rui Zhang, Yu-Jie Hao, Wei-Hua Zhang, Qiao-Ling Han, Zhi-Peng-Lu. MultiBiometric Feature Identification Technologies Based On Visual Perception and Cognitive Mechanism. 978-1-4244-3425-1/08/\$25.00 ©2008 IEEE.
- [6] Marcin Piekarczyk, Marek.R.Ogiela. The touch-less person authentication using gesture type emulation of handwritten signature templates. 2015 10th International Conference on Broadband and Wireless Computing, Communication and Applications.
- [7] Gaurav Goswami, Brain M.Powell, Mayank Vatsa, Richa Singh, Afzel Noore. FaceDCAPTCHA: Face detection based color image CAPTCHA. Future Generation Computer Systems Volume 31, February 2014, Pages 59- 68.
- [8] Guido Schryen, Gerit Wagner, Alexander Schlege. Development of two novel facerecognition CAPTCHAs: A security and usability study. Computers & Security, Vol. 60, July 2016, Pages95-116.
- [9] Lidia Ogiela, Marek R. Ogiela. Bio-Inspired Cryptographic Techniques in Information Management Applications, 2016.

# Enhancement of Routing Protocols for Mobile Adhoc Network

Rajakumar.R.<sup>a,1</sup>, PandianR<sup>b</sup>, PremJacob .T<sup>b</sup>, Pravin .A<sup>b</sup>, Indumathi.P<sup>c</sup>

<sup>a,1</sup>Assistant Professor, Dept of ECE, Sathyabama Institute of Science and Technology,  
Chennai, India

<sup>b</sup>Assistant Professor, Dept of ECE, Sathyabama Institute of Science and Technology,  
Chennai, India

<sup>c</sup>Professor, Dept of ECE, Madras institute of technology, Anna university, Chennai,  
India

**Abstract.** The primary aim of an ad-hoc network routing protocol is accurate and efficient route creation between node pairs so that messages may be delivered promptly. Route creation need to be done with reduced overhead and bandwidth. This paper presents a scheme to reduce bandwidth and power by the hibernation of nodes for a limited time. The effect of our proposal is then studied by simulation under various conditions and the analysis of the simulation results is done to comprehend the working of our protocol in various areas and how it fares in an application specific scenario.

**Keywords.** Mobile adhoc networks, energy, bandwidth, Network lifetime, fixed infrastructure, AODV

## 1. Introduction

MANET is a group of wireless mobile nodes forming a temporary network devoid of any central infrastructure.

### 1.1 Characteristics of MANET

Wireless, or one-hop networks, till very recently relied on a fixed structure, that is, network nodes linked to fixed infrastructure. Mobile ad-hoc networks (MANETs) provide many-hop communication, eventually allowing network nodes communicating via other nodes. In scenarios wherein networks are created and destroyed in an unplanned manner, MANET is the perfect choice. MANET has a changing topology. A mobile ad-hoc network is an assortment of devices with mobility having a transceiver, with an absent fixed infrastructure. The control and management of MANET is by the nodes.

---

<sup>a,1</sup> Rajakumar R, Assistant Professor, Sathyabama Institute of Science and Technology, Chennai, India.  
E-mail: rrmird@gmail.com

## 2. Enhancement of Routing Protocol

The table-driven ad-hoc routing strategy is akin to the connectionless method where packets are forwarded, without consideration to how often the route(s) are needed. It is based on an updating mechanism of routing table that takes into account the constant transmission of routing information. This is, untrue for on-demand routing protocols. When a node in on-demand protocol requires a route to a new sink, it has to wait till such route can be found out. The routing protocol that we have selected for enhancement is AODV[2]. The routing protocols available for adhoc networks have a few limitations in bandwidth, memory and memory [9-11]. AODV does not need much memory because it is a reactive protocol and hence does not store all the routing information in the table. Our protocol aims at improving the other two tradeoffs, there by all the limitations of adhoc routing protocols can be eliminated. Thus we chose AODV as our basic protocol on which we intend to implement the node hibernation algorithm to increase its efficiency[6].

## 3. Hibernation of Nodes

### 3.1 Algorithm

The implementation of hibernation of nodes to decrease the network traffic and to effectively equalize the power consumption by all the nodes is done as follows. Here, a node that has been recently in use goes to a hibernation state where it remains inactive for a specified amount of time. Thus the power usage is equalized among all the nodes. The following example will provide an idea of what we are trying to implement in the protocol. It depicts a scenario containing 21 nodes. There is no base station. It is adhoc in nature. Such a network can be constructed and broken down in very small time.

### 3.2 Working

Take node 1 as the originating node and node 21 as sink. The Path Discovery process is started when a source node is required to communicate with another node for which it has no routing data..Each node keeps two counters: a node sequence number and a broadcast id. The originating node (node 1) starts path discovery by broadcasting a route request (RREQ) packet to its neighbourhood. The RREQ comprises the below fields:< source address, source sequence number, broadcast id, destination address, destination sequence number, hop count >

The Sink node (node 21) selects the shortest path based on the number of hops traversed and transmits a Route Reply (RREP) through the path chosen (unicast). On receipt of the RREP frame, the source node sends the Ready To Send (RTS) frame to the node. The sink node then transmits the Clear To Send (CTS) frame to the source through the chosen route.

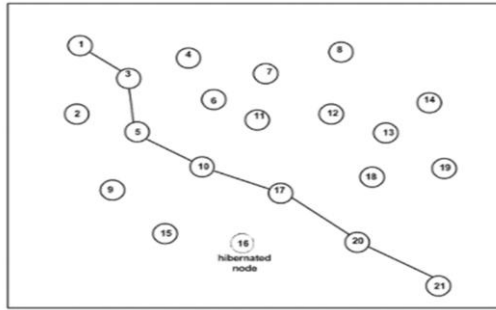


Figure 1. Hibernation of nodes

To conserve Power node 16 goes to hibernation mode, thus the route to node 21 is lost. The Source node again starts off the path discovery procedure and chooses the route with the shortest hop count. The new path selected has more hop counts than the previous one. If the node that goes to hibernation state was a node in critical path, then no route can be established to the destination node. A critical path is a path in which there is only one path connecting groups of nodes. In the above example, node 20 is in critical path, which is the only node connecting node 21 to the rest of the nodes.

#### 4. Simulation and Results

Our protocol increases the network lifetime by effectively utilizing the battery power and it also results in a better spectral efficiency. The parameters that we have used for performance analysis are the packet delivery rate and the number of route requests generated. These parameters are indirectly indicative of the network lifetime and the bandwidth efficiency.

##### 4.1. Software used

A network simulator as we are aware is a piece of software that mimics a network, without a network. Compared to the huge expense implied in setting up an entire test bed containing multiple networked computers, network simulators are far better.

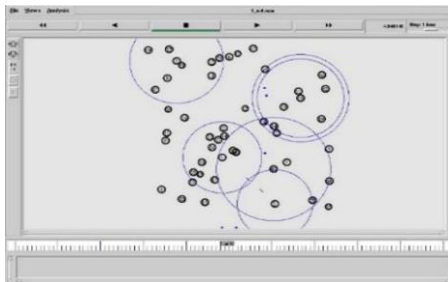


Figure 2. Nam screenshot of the scenario

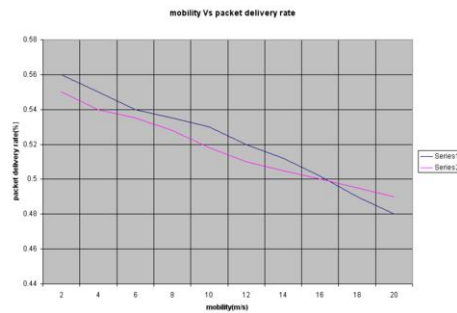


Figure 3. mobility vs packet delivery rate



Setdest is an independent utility available in NS2 to generate random motion for the nodes. Connections between TCP and CBR can be mobile nodes with a traffic-scenario generator script. This script is in NS2 and is named ascbngen.tcl. create CBR

#### 4.2 Mobility vs packet delivery rate

From the simulation it was observed as in Fig.3, that the packet delivery rate goes down with the increase in the mobility from (0-20) m/s. the packet delivery rate is stated as follows  $\text{Packet delivery rate} = \frac{\text{number of packets received}}{\text{number of packets sent}}$ . It is seen from the simulation that not all the packets that are sent are successfully transmitted. A few of the packets are lost during the multiple hops. The packet delivery rate of the modified protocol is better than that of the basic AODV protocol. The packet delivery rate is higher for low to moderate mobility. If the mobility is increased further the packet delivery rate starts to decrease. This is mainly due to the increased mobile nature of the nodes. An increase of about 2 to 3 percentage is observed for mobility values of (0 to 15) m/s. The values of mobility can be varied by using a independent utility that is available inNS2 for creating random motion.

#### 4.3 Mobility vs number of route requests

The number of route requests increases with the increase in the mobility. With increase in the mobility the topology becomes more chaotic thereby lots of route requests and packets get lost during transmission. The number of route requests generated is thus indicative of the control overhead. Thus by reducing the amount of number of route requests the bandwidth consumption is reduced and thereby more number of users can be accommodated within the same bandwidth. The observation shows that the number of route requests decreases by a fraction about 15 to 30 percentage of the original values produced by the basic protocol.

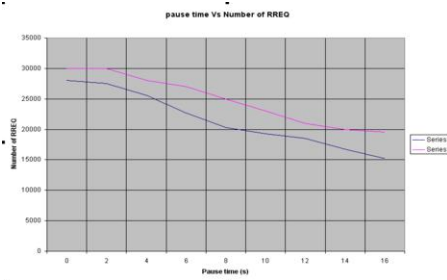
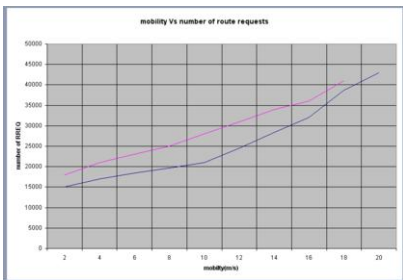


Figure 4.mobility vs number of route requests Figure 5.pause time vs number of route requests

#### 4.4 Pause time vs number of route request

Pause time is defined as the infinitesimal small amount of time for which a node remains stationary in its position between two movements. This factor is also determining parameter in an adhoc network because increase in the pause time will make the network less dynamic and thereby the number of route request generated will be reduced. But for nodes moving in a same direction without changing direction the pause time will be less and thereby it will move away from the near by node. As a

result the route request and other packets may get lost due to less pause time (Fig. 5). The value of the pause time used for simulation is varied from 0 to 20 ms.

## 5. Conclusion

The observations of the above simulations concludes that our protocol fares better than the normal AODV protocol for low density networks and it starts to falter for high traffic networks and highly mobile networks. An increase of about 2 to 3% is observed in the packet delivery rate for low to moderate mobility values of (0 to 15) m/s.(Fig4) This value starts to decrease for higher mobility.The number of route requests lost decreases for the modified protocol when compared to the basic protocol and it varies from 6 to 24 percentage for varying pause times (Fig 5).From the above results it may be observed that the modified protocol performs better for networks where the node mobility is comparatively low. It also performs better with lower number of nodes. The performance starts to decrease for high traffic networks and high mobile networks. This results in application specific use for our protocol. MANET application includes deployment in battlefields to monitor battlefield survivability and for disaster recovery purposes. But for commercial application of adhoc networks like replacing the infrastructured services by adhoc services the modified protocol is not suitable for high traffic and scalability.. As a result the performance can be classified as working well under application specific scenarios. The modified protocol performs better in areas like battlefield survivability and disaster recovery[7],{8}.The future work includes expanding this idea for a hierarchical network like cluster head gateway switch routing and reducing the delay in hibernation by means of a route cache.

## Reference

- [1] Banerjee, Sumanand Misra, Archan (2002). Minimum Energy Paths for Reliable Communication in Multi-hop Wireless Networks, ACM MobiHOC.
- [2] Cartigny, J., Simplot, D. and Stjmenovic, I, (2003). Localized minimum-energy broadcasting in ad-hoc networks, IEEEInfocom 2003.
- [3] Christine Jones, E and et.al, (2001).A Survey of Energy Efficient Network Protocols for Wireless Networks, IETF Wireless Networks, Vol 7 , Issue 4.
- [4] Elbatt, T. , Krishnamurthy, S. , Connors, D. and Dao, S. (2000). Power Management for Throughput Enhancement in Wireless Ad-Hoc Networks, ICC Magazine 2000.
- [5] Elizabeth M.Royer and C-K Toh (1999).A review of current routing protocols for ad-hoc mobile wireless networks, IEEE Personal Communications Magazine.
- [6] Kumar, P. (2003).Power Control and Clustering in Ad-Hoc Networks, IEEE Infocom, Vol 23, Issue 2.
- [7] A. Jabbar, Mahamod Ismail, and Rosdiadee Nordin, (2014). On the Performance of the Current MANET Routing Protocols for VoIP, HTTP, and FTP Applications, Journal of Computer Networks and Communications, Feb, 2014.
- [8] FahadTaha AL-Dhief , NaseerSabri, M.S. Salim , S. Fouad , S. A. Aljunid(2018).MANET Routing Protocols Evaluation: AODV, DSR and DSDV Perspective, MATEC Web of Conferences 150, 06024, pp 1-6.
- [9] Ambeth Kumar V.D (2017). Efficient Routing for Low Rate Wireless Network a Novel Approach, International Journal of Image Mining, Vol. 2, Nos. 3/4, 2017, 2017.
- [10] Nanagasabapathy.K et.al; .Validation system using smartphone luminescence.IEEE International Conference on Intelligent Computing, Instrumentation and Control Technologies (ICICT), Pages: 235 – 239, 6-7 July 2017, Kannur, India.
- [11] Ambeth Kumar .V.Det.al .Cloud enabled media streaming using Amazon Web Services.IEEE (ICSTM), Pages: 195 – 198, 2-4 Aug. 2017, Vel Tech University, Chennai, India (DOI: 10.1109/icstm.2017.8089150).

# Comparative Study of Hybrid Optimizations Technique for On-Chip Interconnect in Multimedia SoCs

Jayshree<sup>a,1</sup>, Gopalakrishnan Seetharaman<sup>b</sup>, and Debadatta Pati<sup>c</sup>

<sup>a,1</sup> Assistant Professor, Dept of ECE, National Institute of Technology, Nagaland, India

<sup>b</sup> Professor, Dept of ECE, Indian Institute of Information Technology, Tiruchirappalli, India

<sup>c</sup> Professor, Dept of ECE, National Institute of Technology, Nagaland, India

**Abstract.** This paper presents the design and analysis of on-chip interconnect architectures for real time Multimedia Systems-on-Chip (MSoC) targeting Internet of Things (IoT) applications. The interconnect architecture provides high flexibility in connection for hardware implementation of reconfigurable neural network. Due to technology's miniaturization in ultra-deep submicron technology, the on-chip interconnect performance and power consumption become a bottleneck. In this paper, the hybrid optimization technique is proposed to address these challenges using schmitt trigger as a repeater and tapering. Here, the proposed optimization technique is incorporated with a dedicated point to point based interconnection (PTP-BI) configuration. A comparative study with others without optimization technique (Model-I) shows the effectiveness of the proposed optimization technique (Model-II). The technology node scaling impacts are also analyzed for both techniques. Finally, the percentage reduction of latency and power consumption are evaluated in two different cases to observe the impacts of varying the interconnect length.

**Keywords.** Global on-chip inter connect, hybrid optimizations, internet-of-things (IoT), multimedia system-on-chip (MSoC), and point-to-point-based interconnection (PTP-BI).

## 1. Introduction

Nowadays, customer demands are accelerating towards high quality of service (QoS), reliability, scalability and security for real-time multimedia, specifically for internet of things (IoT) application [1]–[4]. The architecture design for such applications needs a high speed hardcore processor [5]. A more significant number of memories which follow the design methodology of intellectual property (IP) based blocks instead of the generic gate level [6] on single-chip within a limited silicon area. The design accomplishment is possible with the ongoing miniaturization of the device feature size. The scaling of process technology node has various advantages for device design such as gate latency (Gl) reduces by  $1/s$ , where  $s$  is scaling factor [7]. It provides a system

---

<sup>1</sup>Jayshree, Assistant Professor, Dept of ECE, National Institute of Technology, Nagaland, India.  
Email: jay.chy@nitnagaland.ac.in

designer to embed maximum IP for performing multitask on a single chip whereas the scaling leads to large, interconnect performance deterioration such as interconnect latency (II) increases by s2, low reliability and massive power consumption due to global core interconnection. The global core interconnection creates large wire congestion on single chip [8]. Therefore, it motivates the system designer to shift from computation focused design to an interconnect focused (or communication-focused) model. In interconnect concentric system design there are few challenges such as core placement, floor planning, IP-core mapping, and routing of packets [9]. The main objective of the work is to resolve the IP cores placement, mapping challenge in the MSoC for transmission of the message without any loss and attack. It should provide high throughput, low latency and proper security for global on chip communication. The proposed dedicated point to point based interconnection (PTP-BI) is a more advanced on-chip interconnection technique than previously used technique [10].

The salient feature of the work contribution of the paper are as follows: Initially, every IP core of the video object plane decoder (VOPD) MSoC is designed. Here, two architectures of MSoC are designed using point to point based interconnection (PTP-BI) technique is the name as Model-I (considered as without optimization technique) and hybrid optimization of Schmitt trigger as repeater and tapering is the name as Model-II (considered as with optimization technique). The latency and power consumption for both models are examined at 0.350  $\mu\text{m}$ , and 0.180  $\mu\text{m}$  technologies for various interconnect lengths. Later, the impact of technology scaling on global interconnect has examined and evaluated the percentage reduction of latency and power consumption for Model-I and model-II. Here, the RTL design and synthesis are performed with Quartus-II 14.0 tools and hardware implemented on the Altera FPGA development board, and mentor graphics simulators.

The paper is organized as follows: Section 1 introduces the problem for degradation of the performance and security in MSoCs due to large size of the global interconnect. Background of on chip interfaces and interconnect related work is discussed in Section 2. Section 3 elaborates the proposed architecture and methodology of three on chip interconnect techniques. The results are discussed in Section 4. Finally, Section 5 presents the concise conclusion of the proposed approach.

## 2. Background

An extensive related literature is studied for on-chip interfaces interconnect architecture. Primarily, it aims to rectify the limitations of existing on-chip communication architectures. Next, the purpose of the study is related to review secured, high-performance, and low energy consumption architecture. The pros and cons of the highly competent technique are studied such as the interface is open core protocol (OCP) [11] and virtual component interface (VCI) [12].

The various parameter is analyzed using Vainbrand *et al.* [14], which is discussed below.  $x$  is considered as neurons arranged in PTP-BI, then the following point are as follows:

- a) The link delay is expressed as

$$T(PTP - BI) = R_o C_o \bar{l}^2 \quad (1)$$

where,  $R_o$  and  $C_o$  are resistance and capacitance of the wire per unit length, respectively, and  $\bar{l}$  is the average link length and expressed as  $\bar{l}(PTP-BI) = 2l\frac{\sqrt{x}}{3}$ , total number of links is expressed as,  $\bar{l}_{total}(PTP-BI) = \frac{x(x-1)}{2}$ .

b) The total area is expressed as

$$\text{Area}(PTP-BI) = L(PTP-BI) \times \bar{w} \quad (2)$$

where,  $\bar{w}$  is constant number of wires per link,  $L(PTP-BI)$  is the total length of all PTP-BI connections can be calculated as  $\bar{l}_{total}(PTP-BI) \times \bar{l}_{total}(PTP-BI)$ , here,

$$L(PTP-BI) = \frac{1}{3}l(x-1)x\sqrt{x}.$$

c) The maximum link architecture frequency is expressed as

$$f_{arch}(PTP-BI) = \frac{1}{T(PTP-BI)} = \frac{1}{R_o C_o \bar{l}^2} \quad (3)$$

d) The power dissipation is mainly dynamic power dissipated on the link and gate capacitances and is expressed as

$$P_D(PTP-BI) \cong f_{arch}(PTP-BI) C_T U(PTP-BI) V_{dd}^2 \quad (4)$$

where,  $U(PTP-BI)$  is utilization factor,  $V_{dd}$  is supply voltage and  $C_T$  is total capacitance in link.

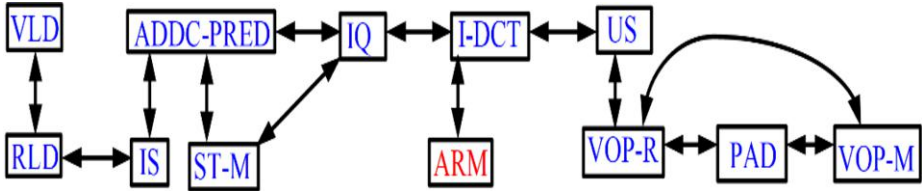
### 3. Architecture and Methodology of Proposed On-chip Interconnection Technique for MSoC

In this section, the proposed interconnect architectures are discussed for VOPD multimedia benchmarks with the proposed methodology. The VOPD architecture is elaborated here with two proposed interconnections techniques.

#### 3.1. Dedicated PTP-BI Technique for Cores Placement and On-Chip Communication

The implementation of the PTP-BI methodology for VOPD system architecture has been discussed in this subsection. This architecture is named as Model-I and its configuration is shown in Fig. 1. This configuration provides the most rapid transmission because of the dedicated link is present with all the macros [10]. In this design, three different types of PTP-BI are considered and classified as global, intermediate and local interconnects. In the first global interconnect, the size of the architecture is considered up to 8.5 mm for rendering power supply to the on-chip. Here, the height, width and thickness are taken in the ratio of 3 : 8 : 4. In the second intermediate interconnect, the size of the architecture is considered up to 4.5 mm for linking far distance IP cores to the on-chip. Here, the height, width and thickness ratio is 6 : 9 : 4. Similarly, for the third local interconnect, size of the architecture is

considered up to 1.5 mm to link the consecutive IP cores to on-chip. In this interconnect, the widths are considered as half of thickness and height.

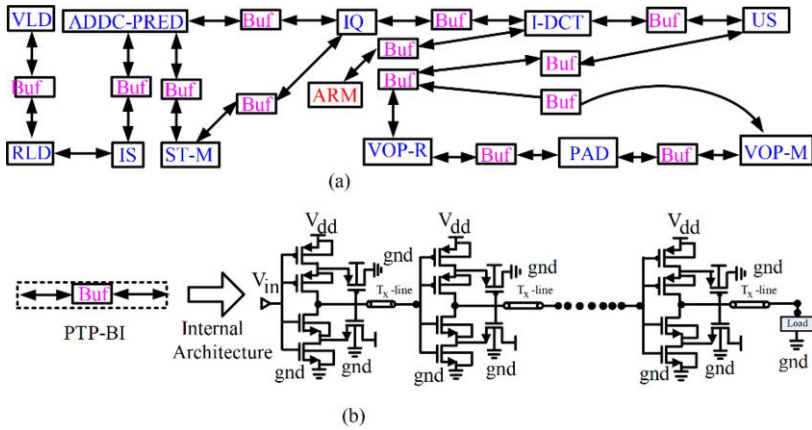


**Figure 1.** Model-I: The PTP-BI of VOPD without optimization.

### 3.2. Optimization with Schmitt Trigger as the Repeater and Tapering

In the case of without optimization technique, the effects of the resistance and capacitance are examined. Then, it is observed that the resistance and capacitance of interconnect rises linearly with an interconnecting length which leads to a quadratic increase in the latency. To reduce the latency and power consumption, a novel hybrid optimization technique is proposed. The implementation of two different optimization techniques such as the Schmitt triggers is considered a buffer with tapering in the interconnect of VOPD architecture. This architecture is named as Model-II and its configuration is shown in Fig. 2(a). The internal interconnect architecture with the optimization component is shown in Fig. 2(b). This Schmitt trigger switches to an input signal faster than the CMOS buffer repeater presented in [13]. The Schmitt trigger is designed with NMOS and PMOS transistors, and PMOS width kept thrice of that of NMOS. Here, the tapering is also performed in the interconnect.

The modified Schmitt trigger buffer is used as a repeater core to split the interconnect into equal parts. The same size is applied as repeaters to function in each section of the design, as shown in Fig. 2. The message propagates accurately from master to slave at low latency and high throughput. The power consumption is reduced by the fast switching. Therefore, the width of interconnect is considered non-uniform. The source end of the interconnect is considered wider which reduces the crucial interconnect resistance. Since this portion of the interconnects charges a maximum of the interconnect capacitance. At the receiver end, the interconnection is narrowed to reduce the total capacitance, but resistance increases due to narrow width which carries a small fraction of the charge. Therefore, the tapering technique supports reducing the interconnect latency. However, the modified buffer using the schmitt trigger increases extra the surface area.



**Figure 2.** Model-I: The brief topology of the interconnect (a) Model-II: The PTP-BI of VOPD with optimization using Schmitt trigger as buffer with tapering; (b) Internal interconnect architecture.

### 4. Result and Discussion

In this section, the simulation results of the proposed interconnection techniques are presented for the VOPD multimedia benchmark. With the help of the PTP-BI technique, two different architectures of MSOCs are designed. The first technique is Model-I (Considered as without optimization) and the second technique is Model-II (Considered as with optimization). The optimization technique is known as hybrid optimization of schmitt trigger as repeater and tapering. The specification of interconnect for several variables such as interconnect length ( $l$ ), thickness ( $t$ ), height ( $h$ ), width ( $w$ ), spacing ( $S$ ), and constant factor ( $k$ ) are analyzed for both models as listed in Table I. To evaluate the PTP-BI technique at  $0.35 \mu\text{m}$  for  $l = 1.5 \text{ mm}$ ,  $4.5 \text{ mm}$ , and  $8.5 \text{ mm}$ , respectively.

**Table 1.** Specification of interconnects.

S. No.	Variables	Model-I at $0.35 \mu\text{m}$			Model-II at $0.18 \mu\text{m}$		
		$l = 1.5 \text{ mm}$	$l = 4.5 \text{ mm}$	$l = 8.5 \text{ mm}$	$l = 1.5 \text{ mm}$	$l = 4.5 \text{ mm}$	$l = 8.5 \text{ mm}$
1.	$t (\mu\text{m})$	0.35	0.55	1.20	0.25	0.45	1.10
2.	$h (\mu\text{m})$	0.55	0.55	0.55	0.35	0.35	0.35
3.	$K$	2.50	2.50	2.50	2.20	2.20	2.20
4.	$w (\mu\text{m})$	0.18	0.60	0.60	0.10	0.20	0.50
5.	$S (\mu\text{m})$	0.18	0.60	0.60	0.10	0.20	0.50

The latency is examined for both the models (Method-I & Method-II) in Table II. From the Table, it is observed that the latency of Model-II is decreased as compared to Model-I at  $l = 1.5 \text{ mm}$ . For further study, the technology scaled from  $0.35 \mu\text{m}$  to  $0.18 \mu\text{m}$  and considered  $l = 1.5 \text{ mm}$ ,  $4.5 \text{ mm}$ , and  $8.5 \text{ mm}$ , respectively for both the models presented in Table II. When the interconnection lengths are increase, then the latency increases. Here, the percentage reductions are evaluated in the latency for

Model-II and compared with Model-I. At 0.35  $\mu\text{m}$  technology, the decrease in latency by 19.76% for  $l = 1.5$  mm, 18.79% for  $l = 4.5$  mm, and 42.24% for  $l = 8.5$  mm, respectively. Similarly, at 0.18  $\mu\text{m}$  technology, the reduction in latency by 8.66% for  $l = 1.5$  mm, 43.12% for  $l = 4.5$  mm and 13.37% for  $l = 8.5$  mm, respectively.

**Table 2.** Calculation of Latency (ns) of Packet in PTP-BI Technique at Various Interconnect Length.

S. No.	$l$ (mm)	Models at 0.35 $\mu\text{m}$			Models at 0.18 $\mu\text{m}$		
		Model-I	Model-II	Reduction (%)	Model-I	Model-II	Reduction (%)
1.	1.5	33.9	27.2	19.76	53.10	48.50	8.66
2.	4.5	97.9	79.5	18.79	389.30	221.40	43.12
3.	8.5	363.8	210.1	42.24	2201.20	1906.80	13.37

Further, the percentage reductions are evaluated in Model-I and Model-II power consumption. For 0.35  $\mu\text{m}$  technology, the power consumption was examined for both models at different interconnect lengths as listed in Table III. Here it has been analyzed that for the same  $l = 4.5$  mm, the power consumption of Model-II decreases compared to Model-I. For further study, the technology is scaled from 0.35  $\mu\text{m}$  to 0.18  $\mu\text{m}$  and considered  $l = 1.5$  mm, 4.5 mm, and 8.5 mm, respectively, for both the models presented in Table III. The technology scaled from 0.35  $\mu\text{m}$  to 0.18  $\mu\text{m}$  for the same values of  $l$  and examined the power consumption increases in the PTP-BI technique. For example, at 0.35  $\mu\text{m}$  technology, the power consumption at  $l = 1.5$  mm is 132.9 mW for Model-I. At 0.18  $\mu\text{m}$  technology, the power consumption at  $l = 1.5$  mm is 262.7 mW for Model-I. The percentage power consumption reduction of Model-II is compared with Model-I presented in Table III. At 0.35  $\mu\text{m}$  technology, the decrease in power consumption by 2.40% for  $l = 1.5$  mm, 32.44% for  $l = 4.5$  mm, and 20.13% for  $l = 8.5$  mm, respectively. Similarly, at 0.18  $\mu\text{m}$  technology, the reduction in latency by 42.78% for  $l = 1.5$  mm, 24.93% for  $l = 4.5$  mm and 11.44% for  $l = 8.5$  mm, respectively.

**Table 3.** Calculation of Power Consumption (mW) of the PTP-BI at Various Interconnect Length.

S. No.	$l$ (mm)	Models at 0.35 $\mu\text{m}$			Models at 0.18 $\mu\text{m}$		
		Model-I	Model-II	Reduction (%)	Model-I	Model-II	Reduction (%)
1.	1.5	132.90	129.70	2.40	262.7	150.3	42.78
2.	4.5	328.20	221.70	32.44	510.9	383.5	24.93
3.	8.5	798.30	637.60	20.13	1025.8	908.4	11.44

## 5. Conclusion

In this paper, effective on-chip interconnection techniques are presented which have been integrated with the design of MSoCs. From the results, it is observed that the rise in the latency of the data transactions and the power consumption for interconnects as technology node evolves from 0.35  $\mu\text{m}$  to 0.18  $\mu\text{m}$ . With the increase of interconnect length, the latency and power consumption are reducing with an optimization technique. Still, these latency and power consumption of data transactions in the interconnect values are large. It necessitates a modification in the design of interconnect architecture.



The result shows that the more promising, highly secure and high performance. But it undergoes a scalability problem due to immense complexity, expense and configuration effort. This encourages work towards scalability improvement of architecture in the future. It can be continued towards designing more promising interconnect architecture to satisfy customer requirements such as high performance and high QoS.

## References

- [1] M. K. Meher. P. Modifications in CMOS dynamic logic style: A review paper, *J. Inst. Eng. India Ser. B*, vol. 96, pp. 391–399, 2015.
- [2] M. R. S. P. e. a. Biswas, B., An efficient VLSI architecture of the enhanced three step search algorithm, *J. Inst. Eng. India Ser. B*, vol. 97, pp. 303–309, 2016.
- [3] Sanchez Correa.R and David.J.P .Ultra-low latency communication channels for FPGA-based HPC cluster, *Integration*. vol. 63, pp. 41–55, 2018.
- [4] Babu.P.Reconfigurable FPGA architectures: A survey and applications. *J. Inst. Eng. India Ser. B*, vol. 102, p. 143U156, 2021.
- [5] N. S. Parihar. A., High-speed high-throughput VLSI architecture for RSA montgomery modular multiplication with efficient format conversion, *J. Inst. Eng. India Ser. B*, vol. 100, pp. 217–222, 2019.
- [6] Nurmi.J, Tenhunen.H , Isoaho.J, and Jantsch.A .*Interconnect-Centric Design for Advanced SoC and NoC*, 1st ed. Springer Publishing Company, Incorporated, 2010.
- [7] Ebrahimi Jarihani.A, Sarafi.S, M. Köberle, J. Sturm, and A. M. Tonello, Characterization of on-chip interconnects: Case study in 28 nm CMOS technology, in *Austrochip Workshop on Microelectronics (Austrochip)*, Oct 2019, pp. 93–99.
- [8] Bhattacharjee.P and Sadhu.A, VLSI transistor and interconnect scaling overview, *J. Electron. Des. Technol.*, vol. 5, no. 1, pp. 1–15, 01 2014.
- [9] W. C. T. Sao Jie Chen, Ying Cherng Lan and Y.-H. Hu, *Reconfigurable Networks on Chip*. Springer, New York, NY, 2012.
- [10] Jayshree, S. Verma, and A. Chatterjee, A methodology for designing LVDS interface system, in *Sixth Int. Symp. Embed. Comput. Syst. Des. (ISED)*, Dec 2016, pp. 284–288.
- [11] I. Mackintosh, *Open core protocol international partnership (OCP-IP)*, 2005.
- [12] Rowen.C and Leibson.S, *Engineering the Complex SoC: Facts, Flexible Design with Configurable Processors*. Prentice Hall, 2004.
- [13] Jayshree and G. Seetharaman, Design and analysis of novel interconnects with network-on-chip LVDS transmitter for low delay, in *NASA/ESA Conf. Adapt. Hardw. Syst. (AHS)*, Aug 2018, pp. 204–209.
- [14] Vainbrand.D and Ginosar.R .*Network-on-Chip Architectures for Neural Networks*, 2010 Fourth *ACM/IEEE Int. Symp.on Networks-on-Chip*, Grenoble, France, 2010, pp. 135-144, doi: 10.1109/NOCS.2010.23.

# Analysis of Vedic, Wallace Tree and Array Multipliers

G.Srividhya<sup>a,1</sup>, D.Kalaiyarasi<sup>b</sup>, N.Pritha<sup>b</sup>, S.L.Bharathi<sup>b</sup>

<sup>a,1,b</sup>Assistant Professor, Dept. of ECE, Panimalar Engineering College, Chennai, India

**Abstract-** Multiplications are the most important and crucial operation in any system. They are done through the process of repetitive addition. Since speed is necessary in any factor therefore multiplication must also be done in a faster way so that they are utilized properly for a faster result. This paper gives a detailed explanation on all three multipliers and compares them accordingly-In this paper, three various multiplication methods are considered and simulated. Three structural multipliers such as Vedic, Wallace tree and array multipliers are compared and their output is shown through the FGPA. For comparison, the results of multipliers are synthesized and simulated using XILINX.ISE.14.5 tool .Later the comparison is concluded by evaluating their utilization of the device.

**Keywords** -Vedic Multiplier (VM), Wallace Tree Multiplier (WTM), Array Multipliers (AM)

## 1. Introduction

Multiplication operation plays a very important role in micro processing, DSP and other communication applications. Consider two 8-bit number, From the Figure.1, it can be.

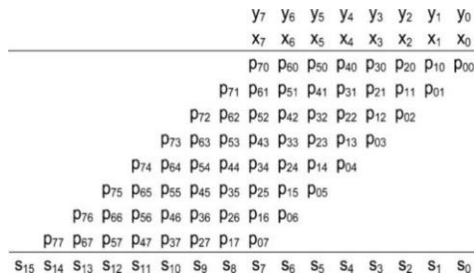


Figure 1. Multiplication process

<sup>1</sup>Srividhya G ,Assistant Professor , Dept of ECE Panimalar Engineering College, Chennai; Email:srividhyal08@gmail.com

observed that multiplication is just a lot of addition involved. Hence these multipliers are designed using full adders and half adders. The multiplier is efficiently built using a compactor to make it suitable for various implementations of speed, low power and compact VLSI [1]A high-speed, two-complement, m-bit by n-bit parallel array multiplication algorithm is outlined [2]. [3] Introduces a new architecture for the multiplier recoded by radix-2 Booth, where its delete extended sign bits. One of the basic arithmetic operations is multiplication and it takes considerably more hardware resources and processing time than addition and subtraction [4]. It is a good direction to minimize the number of operations, thus reducing a dynamic force that is a big part of total power dissipation, in order to reduce substantial power usage of multiplier nature [5][9-10]. The performance study of the Wallace-tree, Array and Baugh-Wooley multiplier architectures has been carried out [6]. The delay and power dissipation of the Wallace Tree multiplier is lower, while the Array multiplier is better for applications with reduced area but not speed. In [7] a low-power one-bit full adder had been proposed which is used in the Arithmetic Logic Unit configuration. Some strategies that are helpful in minimizing leakage power have been implemented in [8]. An adjustment to decrease the amount of half adders is presented to the reduction of Wallace that guarantees that the delay is the same as for the reduction of conventional Wallace [11].The design of low-power high-speed algorithms for arithmetic logic units using ancient mathematics techniques and implementing their hardware is proposed in [12]. In this paper, three multipliers are discussed. They are:

1.1. Vedic Multiplier

Vedic multiplier is based on 16 Vedic sutras which describes natural way of solving whole range of mathematical problems. It produces product and sum in a single step. Their calculations are done parallel which makes Vedic the fastest multiplier. As the number of bits increases in a Vedic multiplier the timing delay decreases greatly when compared to other multiplier. The block diagram of VM is shown in Figure 2.

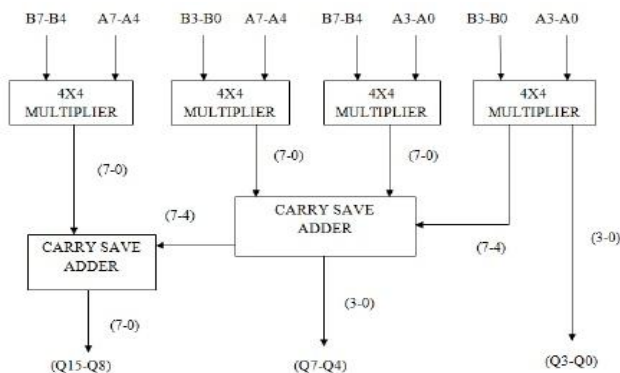


Figure 2. Block diagram of VM

### 1.2. Wallace Tree Multiplier

Wallace tree multiplier is an efficient implementation of digital circuit is shown in Figure 3. Wallace tree multipliers are considered to perform efficiently but they are hard to implement. Although they are considered to be the faster multiplier than simple array multiplier, they include Partial Product Generation, Reduction and Addition. At first normal operations take place, then the products are generated and secondly the heights of the set of products are reduced to two by placing adders. Once they are reduced to two additions is performed. Here  $A = A_0 A_1 A_2 A_3 A_4 A_5 A_6 A_7$  and  $B = B_0 B_1 B_2 B_3 B_4 B_5 B_6 B_7$  and the result is given by P.

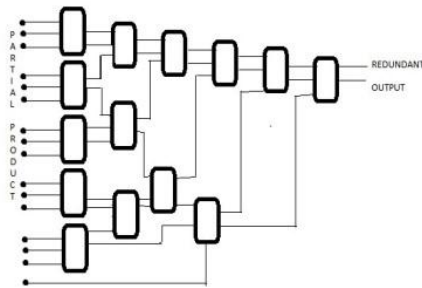


Figure 3. Block diagram of WTM

### 1.3. Array Multiplier

The array multipliers are the layout of combinational multipliers is shown in Figure 4. Although it utilizes more gates the performance is easily increased using pipeline technique. The add and shift algorithm is followed in array multipliers. The partial products are generated and shifted according to bit orders and addition operation take place. The result for multiplying two numbers is obtained by using AND logic gate that gives bit of the product .Consider 8X8 bit multiplication with  $A= X_0 X_1 X_2 X_3 X_4 X_5 X_6 X_7$  and  $B= Y_0 Y_1 Y_2 Y_3 Y_4 Y_5 Y_6 Y_7$  and the result is given by S.

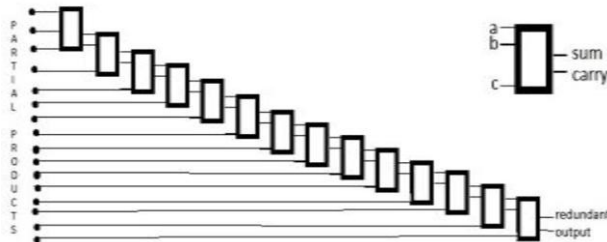


Figure 4. Block diagram of AM

## 2. Simulation Result

To generate output two inputs are given to a multiplier. A="157"(in decimal number system), B="129"(in decimal number system) Output ="20253"(in decimal number system) which is shown in Figure 5.



Figure 5. Simulation result of the Multiplier

### 2.1. FPGA Implementation

The final procedure is to implement them in a hardware kit is shown in Figure 6. The result is done in both hardware and software using XILINX. Here initially a0 is in on state (a0=1) and b1 is in on state (b1 =1) and other values set as '0' that will be displayed in data input switches. The output is displayed in LED Indicators. There are 8 LED Indicators.X0 (1) is in on state(X0(1) =1) and others will be in off state. The performance Comparison of Vedic, Wallace and Array multipliers are given in Table 1and in figure 7.

Table 1. Performance Comparison of Vedic, Wallace and Array multipliers

TYPE OF MULTIPLIER	DELAY (ns)	LUT (used and availability)
VM	27.908ns	126 out of 7168
WTM	31.962ns	131 out of 7168
AM	34.04ns	156 out of 7168



Figure 6. Hardware Implementation

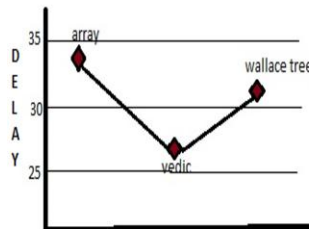


Figure 7. Performance comparison

### 3. Conclusion

The implementation of 8x8 multipliers such as Vedic multiplier, Wallace tree multiplier and array multipliers are done. It is observed that delay in each multiplier vary respective to their design and hence it is found that Vedic multiplier uses less delay than any other multipliers and considered to be the fastest in its performance. Also the utilization by Vedic multiplier is less than other multipliers. Therefore in this paper it is verified that Vedic multiplier is the most suitable technique to implement complex mathematical problem.

### References

- [1] Bharathi.S.L,Pritha.N,Srividhya.G,PadmaPriya.D .A Frame of Multiplier using Compactor. Int.Journal of Innovative Science and Research Technology, ISSN: 2456-2165,Vol. 3 Issue 3, March – 2018.
- [2] Baugh.C.R and Wooley.B.A. A Two's Complement Parallel Array Multiplication Algorithm. IEEE Transactions on Computers, vol. 22, pp. 1045–1047, December 1973.
- [3] Badghare.R.M, Mangal.S.K, Deshmukh.R.B, Patrikar.R.M (2009).Design of Low Power Parallel Multiplier. Journal of Low Power Electronics, Volume 5, Number 1, April 2009, 31-39.
- [4] Adder Subtractor Design Islamic University of Gaza, Faculty of Engineering Department of Computer Engineering Fall 2011 ECOM 4113: Digital Design LAB Eng. Ahmed Abumarasa
- [5] Sumit R. Vaidya, D.R. Dandekar, Delay-power Performance Comparison of Multipliers in VLSI Circuit Design, IJCNC, vol. 2,No. 4,pp. 47-56,July 2010
- [6] P.V. Rao, Cyril Prassana Raj P,S. Ravi,VLSI Design and Analysis of Multipliers for Low Power ,IEEE 2009 Fifth International Conference On Intelligence Information Hiding and Multipedia Signal processing,pp. 1354-1357,2009
- [7] Esther Rani.T, M. Asha Rani, Dr. Rameshwar rao, Area Optimized Low Power Arithmetic And Logic Unit 978-1-4244-8679-3/11/\$26.00 ©2011 IEEE.
- [8] Kalaiyarasi.D and Saraswathi.M .Design of an Efficient High Speed Radix-4 Booth Multiplier for both Signed and Unsigned Numbers, International Conference on Advances in Electrical, Electronics, Information, Communication and Bio-Informatics (AEEICB) 27-28 Feb. 2018, IEEE 2018.
- [9] AmritaNanda, Design and Implementation of Urdhva-Tiryakbhyam Based Fast 8×8 Vedic Binary Multiplier IJERT, ISSN: 2278-0181,Vol. 3 Issue 3, March – 2014
- [10] Kalyani.P , Dr. P. Satishkumar , Dr. K. Ragini- Various Low Power Techniques for CMOS Circuits , P. Kalyani et al Int. Journal of Engineering Research and Applications, ISSN : 2248-9622, Vol. 3, Issue 6, Nov-Dec 2013, pp.330-333
- [11] Waters.R.S, Swartzlander.E.E .A reduced complexity Wallace multiplier reduction, IEEE Transactions on Computers, vol. 59, no. 8, pp. 1134-1137, 2010.
- [12] Vamshi Krishna.V, Naveen Kumar.S. High Speed,Power and Area efficient Algorithms for ALU using Vedic Mathematics. International Journal of Scientific and Research Publication, Volume 2, Issue 7 july 2012.

# A Novel Approach to Evaluate Reduced Inter Symbol Interference in UFMC Systems

Elavel Visuvanathan. G<sup>a,1</sup> and Jaya. T<sup>b</sup>

<sup>a,1</sup>*Research Scholar, Dept. of ECE, Vels Institute of science, Technology and Advanced Studies (VISTAS)*

<sup>b</sup>*Assistant Professor, Dept. of ECE, Vels Institute of science, Technology and Advanced Studies (VISTAS)*

**Abstract.** The UFMC modulation scheme has been proposed as a solid competitive framework for future portable fifth generation communication. UFMC can be considered as a candidate waveform for 5G communications since it gives strength against Inter Symbol Interference (ISI) [1]. Inter-symbol interference prompted error can make the receiver neglect to reproduce the original data. Equalizers in the receivers, which are extraordinary sorts of filters, moderate the direct twisting created by the channel [2]. On the off chance that the channel's time-fluctuating qualities are known from the earlier, at that point, the ideal setting for equalizers can be worked out. But in practical systems the channel's time-changing attributes are not known from the earlier, so adaptive equalization method is applied in this paper based on the LMS algorithms. Adaptive equalizers are adjusted, or change the estimation of its taps as time advances [3].

**Keywords.** UFMC, Inter Symbol Interference, adaptive equalization, LMS

## 1. Introduction

The appetite of human culture for more data transmission based applications constraining the cellular industry to progress in the direction of better advancements and is fuelling the improvement of fifth-generation research. By 2020 edge fifth-generation cellular access will be a reality and as of now, trails are going on over the world. At present OFDM method is broadly utilized in remote communications just as in numerous advanced communications for its effectiveness. Notwithstanding, it has disadvantages high. In OFDM Cyclic Prefix causes ISI which is caused because of postponement in the conveyance of the channel is higher than CP length.

---

<sup>1</sup>G. Elavel Visuvanathan, Research Scholar, Dept. of ECE, Vels Institute of science, Technology and Advanced Studies (VISTAS)

E-mail: elavel.visuvanathan@gmail.com

## 2. Universal Filter Multi Carrier

### 2.1 UFMC Transmitter

For the most part in filtered orthogonal frequency-division multiplexing, the whole for band is filtered while in Filter Bank Multicarrier singular subcarriers are filtered. Be that as it may, in the UFMC gathering of subcarriers are filtered. UFMC uses QAM to maintain magnificent proportion, which works with existing MIMOs. The entire area of the UFMC transmitter is shown in Figure 1.

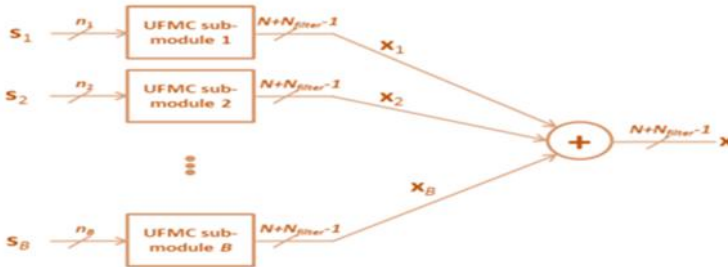


Figure 1. Basic UFMC transmitter structure

Here the entire band of sub-carriers "N" is separated into a few sub-bands. Every sub-band has a static quantity of sub-carriers. Not all sub-bands in the transmission segment have to be used for the transmission. The IFFT is used to eliminate the impediment of the sub-band carrier.

### 2.2 Material and Methods

With the unimaginable improvement of Internet advancements, productive fast data transmission methods over communication channels have become a need of the day. The data transmitted through a band-restricted communication channel experiences direct, nonlinear and added substance bends. So as to decrease the impacts of these contortions an equalizer is utilized at the receiver end.

Figure 2 shows a block-diagram of a communication system with an adaptive equalizer in the receiver. In the event that  $f(t)$  is the consolidated complex baseband drive reaction of the transmitter, and  $b(t)$  is the original data signal, channel and the RF/IF areas of the receiver, the signal got by the equalizer might be communicated as

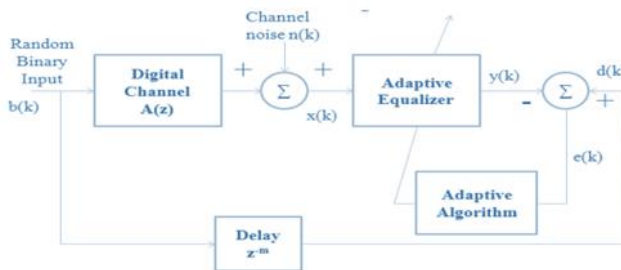


Figure 2. Block Diagram of Adaptive Equalization



$$x(t) = f^*(t) \otimes b(t) + n_b(t) \longrightarrow 1$$

Where  $n_b(t)$  is the base-band noise at the contribution of the equalizer,  $f^*(t)$  is the difficult conjugate of  $f(t)$  and  $\otimes$  indicates the convolution activity.

$$y(t) = n_b(t) \otimes h_{r,q}(t) + f^*(t) \otimes b(t) \otimes h_{r,q}(t) \longrightarrow 2$$

The complex base-band motivation reaction of AFE is given by

$$h_{r,q}(t) = \sum_n C_n \delta(t - nT) \longrightarrow 3$$

Here  $g(t)$  is the common motivational response of the transmitter, the original source data.

$$g(t) = f^*(t) \otimes h_{r,q}(t) = \delta(t) \longrightarrow 4$$

The objective of equalization is to fulfil condition (4). In the recurrence space, condition (2.4) can be communicated as

$$\text{Heq}(f) F^*(-f) = 1 \longrightarrow 5$$

## 2. Result

The simulation of the model under examination was completed utilizing the MATLAB. In figure 3, the performance of the proposed filters is introduced, from which we can obviously observe their trade-offs gave by the differing point. From the figure 3 attenuation and pass-band ripple it clearly shows that value of trade-off starts from minimum value and slowly reaches maximum values.

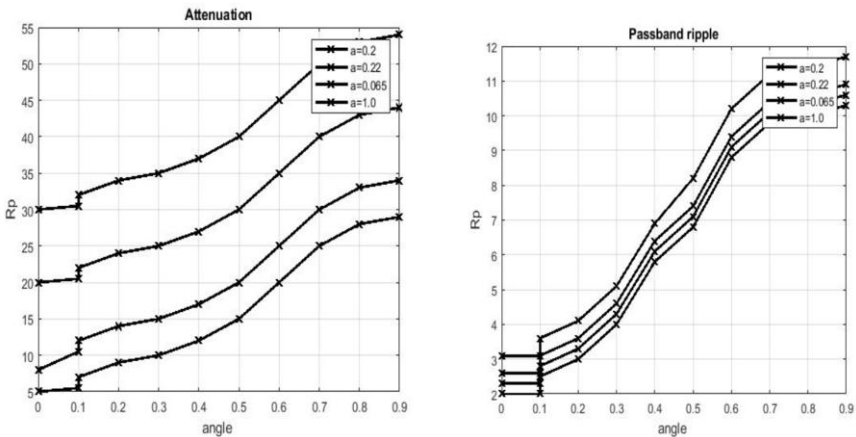
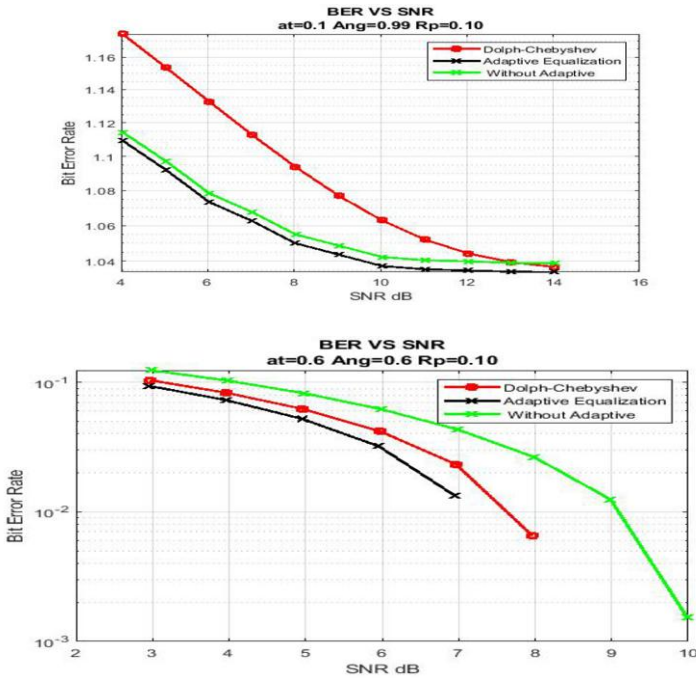


Figure 3. Attenuation and Pass-band ripple

**Table 1.** performance measure of Dolph-Chebyshev Filter and Adaptive Equalization Filter

Dolph-Chebyshev Filter				Adaptive Equalization Filter			
PARAMETERS	SNR (in dB)	BER	Data Rate	PARAMETERS	SNR (in dB)	BER	Data Rate
ANGLE =0	11	0.125	2	ANGLE =0	12	0.0165	2
ANGLE = 20	12	0.124	4	ANGLE = 20	13	0.0154	4
ANGLE =60	14	0.459	8	ANGLE =60	13	0.0147	8
ANGLE =180	10	0.668	16	ANGLE =180	13	0.0258	16
ANGLE =270	11	0.998	32	ANGLE =270	15	0.0965	32
ANGLE =360	11	0.852	64	ANGLE =360	15	0.0258	64

In Figure 4 shows the comparative plot of existing wave shaping filter, adaptive equalization and without equalization.



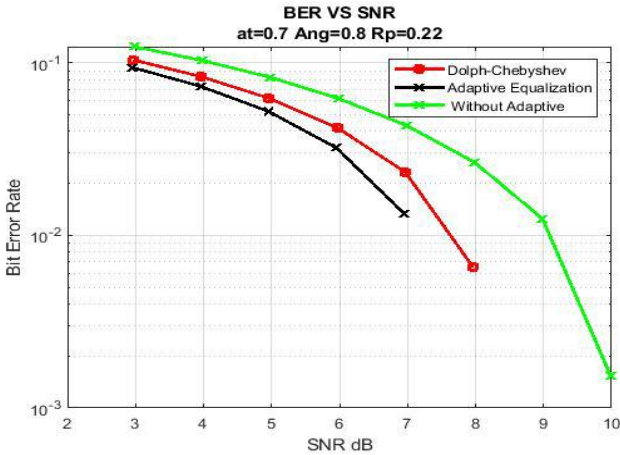


Figure 4. Comparative plot of existing Wave Shaping Filter.

### 3. Conclusion

The performance was analyzed by varying the filter lengths, the type of filters and the Bit Error Rate and the results have been observed. It has been seen that there would be a decrease in the side flap levels with an expansion in the filter length along these lines lessening the out-of-band transmission.

### Reference

- [1] Li, Ye Geoffrey, and Gordon L. Stuber, eds. orthogonal frequency division multiplexing for wireless communications. Springer Science & Business Media, 2006.
- [2] Zhang, Haijian.H , Didier Le Ruyet, Daniel Roviras, Yahia Medjahdi, and Hong Sun. Spectral efficiency comparison of OFDM/FBMC for uplink cognitive radio networks. EURASIP Journal on Advances in Signal Processing 2010 (2010): 4.
- [3] Visuvanathan Ganesan E, Thangappan J. CFO and STO estimation and correction in multicarrier communications using linear filter bank multicarrier. Trans Emerging Tel Tech. 2021;e4229.
- [4] Bochechka.G .Methods of channel estimation based on built in pilot-signals in OFDM systems. Telecommunications and Transport, 2009, No3, pp. 38-42.
- [5] F.Hu, Opportunities in 5G Networks a research and development perspective, CRC Press, 2016
- [6] Tullberg, Hugo, Heinz Droste, Mikael Fallgren, Peter Fertl, David Gozalvez-Serrano, Eiman Mohyeldin, Olav Queseth, and Yngve Seien. METIS research and standardization: A path towards a 5G system. In Globecom Workshops (GC Wkshps), 2014, pp. 577-582. IEEE, 2014.
- [7] Wunder, Gerhard, Peter Jung, Martin Kasparick, Thorsten Wild, Frank Schaich, Yejian Chen, Stephan Ten Brink et al. 5GNOW: nonorthogonal, asynchronous waveforms for future mobile applications. IEEE Communications Magazine 52, no. 2 (2014): 97-105.

# Topic Detection Using Multiple Semantic Spider Hunting Algorithm

E.Elakiya<sup>a,1</sup>, R.Kanagaraj<sup>b</sup> and N. Rajkumar<sup>c</sup>

<sup>a,1</sup>Assistant Professor, Dept of CSE, E.G.S. Pillay Engineering College, Nagapattinam

<sup>b</sup>Assistant Professor (SL.Gr), Dept CSE, Sri Ramakrishna Engineering College, Coimbatore

<sup>c</sup>Professor & Head, Dept of IT, Hindusthan College of Engineering and Technology, Coimbatore

**Abstract.** In every moment, there is a huge capacity of data and information communicated through social network. Analyzing huge amounts of text data is very tedious, time consuming, expensive and manual sorting leads to mistakes and inconsistency. Document dispensation phase is still not accomplished of extracting data as a human reader. Furthermore the significance of content in the text may also differ from one reader to another. The proposed Multiple Spider Hunting Algorithm has been used to diminish the time complexity in compare with single spider move with multiple spiders. The construction of spider is dynamic depends on the volume of a corpus. In some case tokens may related to more than one topic and there is a need to detect Topic on semantic way. Multiple Semantic Spider Hunting Algorithm is proposed based on the semantics among terms and association can be drawn between words using semantic lexicons. Topic or lists of opinions are generated from the knowledge graph. News articles are gathered from five dissimilar topics such as sports, business, education, tourism and media. Usefulness of the proposed algorithms have been calculated based on the factors precision, recall, f-measure, accuracy, true positive, false positive and topic detection percentage. Multiple Semantic Spider Hunting Algorithm produced good result. Topic detection percentage of Spider Hunting Algorithm has been compared to other algorithms Naïve bayes, Neural Network, Decision tree and Particle Swarm Optimization. Spider Hunting Algorithm produced more than 90% precise detection of topic and subtopic.

**Keywords.** Topic Detection, Sub topic Detection, Multiple Spider Model, Multiple semantic Spider Hunting

## 1. Introduction

This electronic era deals with large volumes of unstructured text every day in the form of E-mail, social media post, customer feedback, reviews and other information. there is a huge capacity of data and information communicated through social network and its really challenging to recognize what is important from huge text data. Analyzing huge amounts of text data is very tedious, time consuming, expensive and manual sorting also difficult. Document dispensation phase is still not accomplished of extracting data as a human reader. Topic discovery strategies is used to mine important patterns from text data sets. These topics once recognized can be like trend analysis

---

<sup>1</sup>Elakiya.E, Assistant Professor, Dept of IT , E.G.S. Pillay Engineering College, Nagapattinam ;  
E-mail: er.elakiyaelamaran@gmail.com

document summarization, recommender systems, information navigation etc. With the emerging dimensions of text corpus fashioned on web and focused digital documents, topic detection has twisted into a serious maneuver for browsing, summarizing and clustering the documents. Topic detection is accomplished using both supervised and unsupervised machine learning algorithms like Cluster, Naïve Bayes, Neural Network, and Support Vector Machine etc. Both algorithms have convinced aids and inconvenience also. In the previous investigation, Topic detection technique is useful to certain precise parts like Sentiment Analysis, Social Network, Twitter, Chatting, Medical, Clinical, Micro blog and Community detection. Each investigation paper discussed so for give importance purely single specialized area not additional.

## **2. Related Work**

Corpus are nourish as a contribution to the ERT framework. The main stage expansion hunts the text which contains any Acronyms, Short Forms, Polysemes, Mis-spelling, Icons or Abbreviations. This stage enlarges the short text content and advancing to removal phase. The next stage eliminates the prefix and suffix of the footings and the non- keyword footings. The production of this stage is only keywords and origin footings. The last stage changes nonstop word group into the list of arguments called signs and kept in a database (Elakiya 2017). Aggarwal (2012) Topic detection using text gathering changes toward the optimum cluster midpoint according to the culture amount by adjusting its mass vector. Clustering the recovery outcomes and crisp the content of clusters is investigated Chieh-Jen (2012). Microblog Hot Topic Detection using Particle Swarm Optimization applied to continuous problem and domain variable is not finite Huifang Yugang (2016). Community Detection using Ant Colony Optimization have a dependent sequence of random decisions Ruo Chen Liu (2019).

In the Spider Hunting Algorithm, bag of words are only maintained and it does not focus on the bag of related words. So topic detection may not cent percent accurate in some scenarios, to overcome this issue move for Enhanced Spider Hunting Approach. (Elakiya 2018). Corpus contains additional amount of pages then the amount of paragraphs and sentences also enlarged quickly. Emerging cluster for every sentence and dispensation the clusters to detect topic will revenue more time. To decrease the time complexity rather than using single spider go with multiple spiders. This spider scheme can run numerous procedures in parallel to each other professionally (Elakiya 2018).

## **3. Topic and Subtopic Detection using Word Net**

The flow of topic detection process is given below Collect the input corpus. Preprocess the corpus using ERT Framework Generate the token list Depends on the relationship among terms, association can be drawn between words using word net Graph represents all the terms and their relationships. Detect topic and subtopic based on the relation and their frequencies.

### 3.1. Word Net

Word Net is a collection of lexical database. It consists of group of English words into a cluster of synonyms called Synset. It is a combination of dictionary and thesaurus and word net is mainly used for text analysis (i.e. text summarization and text categorization).

#### Scenario 1

Tendulkar born 24 April 1973 is a previous Indian cricketer and a earlier captain, observed as one of the greatest batsmen of all time.

In the Scenario1, all sentences are preprocessed and extract keywords. Form clusters for each sentence based on the extracted keywords. Each cluster is processed and trained with the topic model and produces the Topic and Subtopic.

Topic percentage=(Number of Sentence belong to particular topic)/(Total number of Sentence)\*100

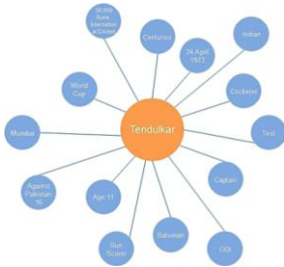


Figure 1. Word Collections for Paragraph1 in scenario 1

Tendulkar → Accident → Boy → Injured

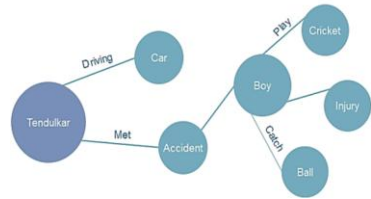


Figure 2. Knowledge Graph for

Sports → Cricket → Tendulkar

### 4. Multiple Semantic Spider Hunting Algorithm

Multiple spider hunting algorithm detects topics based on the text content in the corpus, it does not find the topic on semantic based approach, some topic detection based on the text content is correct but in some scenarios the text may relevant to two or more topics. In these cases, there is a need for semantic search to detect topics.Each cluster is processed with the topic model and produces the Topic and Subtopic. All the clusters are mapped with the Topic

### 5. Opinion Generation

In some cases there is no effective keyword to finalize the Topics. If the two topics are equal priority then generate only opinions not Topics.

Scenario 3

A boy would like to buy one apple; he went to shopping and searching for apple. The boy spends more time to found the expected apple and finally brought the desired apple. In the Scenario 3, The same word apple belongs to two topics Fruit and Technology.

5.1 Opinion Analyze

While generating opinions, there is a need to analyze the opinions either it is a false positive or false negative. The opinion analyze is very helpful to reduce the number of generated opinions. Opinion Analyze classify each opinion based on the maximum relevancy with the content. Precision, Recall and F-score measures are computed for surveying the nature of Topic Detection

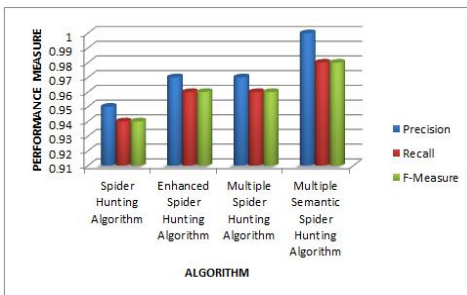


Figure 3. Precision, Recall, F-Measure Vs Various Spider Hunting Algorithms

Table 1. Precision, Recall and F-Measure Values

	Precision	Recall	F-Measure
SHA	0.95	0.94	0.94
ESHA	0.97	0.96	0.96
MSHA	0.97	0.96	0.96
MSSHA	1.00	0.98	0.98

Table 2. True Positive and False Positive Values

	True Positive	False Positive
SHA	0.94	0.06
ESHA	0.96	0.04
MSHA	0.96	0.04
MSSHA	0.98	0.02

5.2 True Positive & True Negative

Sensitivity measures the extent of positives that are effectively recognized using true positive and false positive.

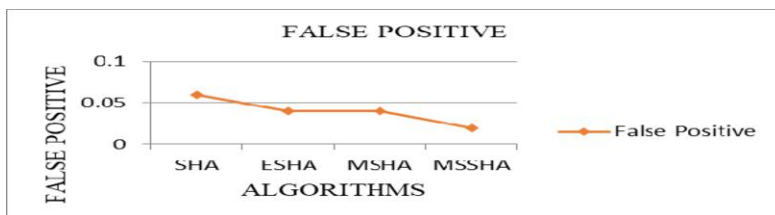


Figure 4. False Positive Vs Various Spider Hunting Algorithms

## 6. Conclusion

A novel method for a topic detection system was presented. Preprocessing is done by using proposed Expansion Removal and Tokenization (ERT) Framework. Designed Spider model and Multiple Spider model with any number topic and subtopic. Trained the model using BBC News Dataset and found emerging top keywords. Topic and subtopic detection is performed by using proposed SHA, ESHA, MSHA and MSSHA. Based on the experimental results, it has been clear that MSSHA achieves more than 90% precise detection of topic and subtopic. In case of non-effective keywords, Opinion is generated and analyzed.

## References

- [1] Elakiya E & Rajkumar N 2019, In Text Mining: Detection of Topic and Sub-Topic using Multiple Spider Hunting Model, *Journal of Ambient Intelligence and Humanized Computing*, Springer.
- [2] Metin Turan & Coskun Sönmez 2015. Automate Document Topic and Subtopic Detection with Support of a Corpus, In *Procedia - Social and Behavioral Sciences* vol.177, pp. 169 – 177.
- [3] Chieh-Jen Wang, Yung-WeiLin, Ming-Feng Tsai & Hsin-Hsi Chen 2012. Mining subtopics from different aspects for diversifying search results Springer Science, Business Media New York, pp. 452-483.
- [4] Hyui Geon Yoona, Hyungjun Kima, Chang Ouk Kima & Min Songb 2016. Opinion polarity detection in Twitter data combining shrinkage regression and topic modeling, *Journal of Informetrics* vol.10, 634–644.
- [5] Elakiya E & Rajkumar N 2018. Efficient Detection of Text Data Topic and Tracking System Based on Enhanced Spider Hunting Technique – ESH, *Taga Journal of Graphic Technology*.
- [6] Mujin Kim, Youngjin Park & Janghyeok Yoon 2016, Generating patent development maps for technology monitoring using semantic patent-topic analysis, *Computers & Industrial Engineering* vol.98, pp. 289–299.
- [7] Nenkova, A & McKeown, K 2012. A Survey of Text Summarization Techniques, *Mining Text Data*. Springer US, pp. 43-76.
- [8] Elakiya E & Rajkumar N 2018 .Topic Detection using Spider Hunting Algorithm, *Journal of Computational and Theoretical Nanoscience*
- [9] Martin Riedl & Chris Biemann 2012. Text Segmentation with Topic Models *JLCL 2012 – Band* vol.27(1), pp. 47-69.
- [10] Aggarwal, Charu C & Cheng Xiang Zhai 2012. A survey of text clustering algorithm, In *Mining Text Data*, pp. 77-128. Springer US.
- [11] Wu, Q, Zhang, C, Hong, Q & Chen, L 2014, Topic evolution based on LDA and HMM and its application in stem cell research, *Journal of Information Science*, vol. 40(5), pp. 611–620.
- [12] Le, Q & Mikolov, T 2014, Distributed representations of sentences and documents, in: *Proceedings of the 31st International Conference on Machine Learning (ICML-14)*, pp. 1188–1196.
- [13] Aksoy, F, Can & Kocerberber, S 2011, ‘Novelty detection for topic tracking *Journal of the American Society for Information Science and Technology*’, pp. 777–779.
- [14] Bhanuse, S, Shailesh, D & Kamble, Sandeep, M 2016, Text Mining using metadata for generation of side information’ *Procedia Computer Science*, vol. 78, pp. 807-814.
- [15] Caroline Langlet & Chloé Clavel 2016, Grounding the detection of the user’s likes and dislikes on the topic structure of human-agent interactions *Knowledge-Based Systems*, vol. 106, pp. 116–124.
- [16] Scott Jensena, Xiaozhong Liub, Yingying Yuc & Stasa Milojevicd 2016., Generation of topic evolution trees from heterogeneous bibliographic networks *Journal of Informetrics* vol. 10, pp. 606–621.
- [17] Ruochen Liu, Jiangdi Liu, Manman He 2019, A multi-objective ant colony optimization with decomposition for community detection in complex networks, *Transactions of the institute and measurement and control* vol. 41, pp. 2521–2534.
- [18] Huifang ma, Yugang Ji, Xiaohong Li, Runan zhou 2016. A microblog hot topic detection algorithm based on discrete particle swarm optimization *Pacific Rim International Conference on Trends in Artificial Intelligence* pp. 271–282.
- [19] Elakiya E & Rajkumar N 2017, Preprocessing using ERT Model, *IEEE Xplore*.



- [20] K. Nanagasabapathy et.al;, Validation system using smartphone luminescence, IEEE International Conference on Intelligent Computing, Instrumentation and Control Technologies (ICICT), Pages: 235 – 239, 6-7 July 2017, Kannur, India
- [21] V. D. Ambeth Kumar et.al;, Cloud enabled media streaming using Amazon Web Services, IEEE International Conference on Smart Technologies and Management for Computing, Communication, Controls, Energy and Materials (ICSTM), Pages: 195 – 198, 2-4 Aug. 2017, Vel Tech University, Chennai, India (DOI: 10.1109/icstm.2017.8089150)
- [22] B. Aravindh et.al;, A novel graphical authentication system for secure banking systems, IEEE International Conference on Smart Technologies and Management for Computing, Communication, Controls, Energy and Materials (ICSTM), Pages: 177 – 183, 2-4 Aug. 2017,
- [23] V.D.Ambeth Kumar et.al, (2016), An Efficient Security System for Data base Management from Illegal Access, IEEE International Conference on Wireless Communications, Signal Processing and Networking (WiSPNET), SSN Engineering College, Chennai, India, 23-25 March, 2016
- [24] V.D.Ambeth Kumar (2017), Efficient Routing for Low Rate Wireless Network a Novel Approach, International Journal of Image Mining, Vol. 2, Nos. 3/4, 2017, 2017
- [25] K. Sabarinathan et.al ., “ Machine Maintenance Using Augmented Reality”, 3rd International Conference on Communication and Electronics Systems (ICCES), 2018. (DOI: 10.1109/CESYS.2018.8723900)
- [26] R. Subha Shini et.al., “ Recurrent Neural Network based Text Summarization Techniques by Word Sequence Generation”,IEEE International Conference on Inventive Computation Technologies (ICICT), 2021, DOI: 10.1109/ICICT50816.2021.9358764

# FPGA Implementation of Protected Compact AES S-Box Using CQCG for Embedded Applications

R.Sornalatha<sup>a,1</sup>, N.Janakiraman<sup>b</sup>, K.Balamurugan<sup>a</sup>, Arun Kumar Sivaraman<sup>c</sup>, Rajiv Vincent<sup>c</sup> and A.Muralidhar<sup>c</sup>

<sup>a,1</sup>Shanmuganathan Engineering College, Pudukkottai, India

<sup>b</sup>K.L.N. College of Engineering, Madurai

<sup>c</sup>School of CSE, VIT University, Chennai

**Abstract.** In this work, we obtain an area proficient composite field arithmetic Advanced Encryption Standard (AES) Substitution (S) byte and its inverse logic design. The size of this design is calculated by the number of gates used for hardware implementation. Most of the existing AES Substitution box hardware implementation uses separate Substitution byte and its inverse hardware structures. But we implement the both in the same module and a control signal is used to select the substitution byte for encryption operation and its inverse for the decryption operation. By comparing the gate utilization of the previous AES S-Box implementation, we reduced the gate utilization up to 5% that is we take only 78 EX-OR gates and 36 AND gates for implementing the both Substitution byte and its inverse. While implementing an AES algorithm in circuitry or programming, it is liable to be detected by hackers using any one of the side channel attacks. Data to be added with a random bit sequence to prevent from the above mentioned side channel attacks.

**Keywords.** Coupled Quadratic Congruential Generator (CQCG), Combinational circuitry S-box, Tiny AES Substitution byte and its inverse, AES, Cryptography, Random bit sequence.

## 1. Introduction

The coupled quadratic congruent generator is used to generate a random bit sequence, which is used to enhance the security of Substitution byte and its inverse. Modulo – 2 addition is performed between actual S-box value and the random bit sequence which is obtained using CQCG. Masked AES S-box is the resultant of the aforesaid operation. Previously S-box was implemented as a ROM table, which requires 256bytes of memory to store. This needs to be incorporated a separate memory to perform Substitution byte and its inverse operation. After performing Substitution byte and its inverse operations this memory is not useful. So, we try to reduce the

---

<sup>1</sup>Sornalatha R, Shanmuganathan Engineering College, Pudukkottai, India  
Email: rslece@gmail.com

memory usage in compact embedded devices such as smart card [10]. Therefore, we choose a combinational circuitry to replace the existing S-box ROM table [1]. Whenever we need a higher security for data transmission, we can select AES [12] as a cryptographic algorithm [7]. An entire work is simulated using Verilog HDL and it is implemented using Spartan – 3 FPGA device [4].

### 2. CFA approach in AES S – box

To optimize AES S-box combinational circuitry, we are using Composite Field Arithmetic (CFA) implementation which is mentioned in earlier works [2]. In order to achieve area reduction, we choose coupled quadratic congruential generator as a random bit sequence generator. CQCG is more secured pseudo random bit generator technique compared to other pseudo random bit generator methods like linear congruential generator, linear feedback shift register, chaotic based pseudo random bit sequence generator [5]. In order to obtain a substitution byte first we have to calculate the multiplicative inverse of the data given and next we have applied an affine transformation.

Multiplicative inverse is obtained by using Galois field ( $2^8$ ) in normal basis. It is more complicated while implementing in combination circuits [6]. Instead of  $GF(2^8)$  multiplicative inversion, we use  $GF(2^4)$  multiplier, inverter as well as  $GF(((2^2)^2)^2)$  multiplier, inverters. Therefore the complexity of the combinational circuit is optimized significantly [3]. Both encipher and decipher in AES have same key, so it is called shared-key encryption algorithm. The data which is used in encryption/decryption of AES is in 128 bits block. Many “rounds” of processing has been done in each block of data. Four steps involved in each round of operation. 128 bits, 192 bits, or 256 bits are the allowed key sizes in AES algorithm [11]. Multiplicative inversion is the significant expensive operation in the substitution byte.

### 3. Computation of multiplicative inversion

The field  $B$  in Phase two is not built smearing a single degree-8 augmentation lead to  $GF(2)$ , although spread over numerous additions of lesser steps. To decrease the cost of Phase 2 as greatly as possible, we constructed the field  $B$  by reiterating degree-2 extensions in a polynomial root by means of these irreducible polynomials:

$$\left. \begin{array}{l} GF(2^2) \\ GF((2^2)^2) \\ GF(((2^2)^2)^2) \end{array} \right\} \begin{array}{l} : x^2+x+1 \\ : x^2+x+\phi \\ : x^2+x+\lambda \end{array} \tag{1}$$

Where  $\phi = \{10\}_2$ ,  $\lambda = \{1100\}_2$ . The inverter over the composite field above has fewer  $GF(2)$  operators as given in equation 1 compared with the field  $B$  used in the equation 2.

$$\begin{array}{ll} GF(2^4) & :x^2 + x + 1 \\ GF((2^4)^2) & :x^2 + x + \omega_{14} \end{array} \tag{2}$$

Where  $\omega_{14} = \{1001\}_2$ .

Figure 1 depicts hardware implementation of substitution byte and its inverse. GF  $((2^m)^n)$  that is built by an augmentation degree- $n$  later an augmentation degree- $m$ , calculating the multiplicative reciprocals be able to do as a group of operations above the subfields GF  $(2^n)$ . Figure 2 to 4 shows the internal diagrams of proposed AES S-Box and Inverse S-Box using composite field arithmetic in normal basis.

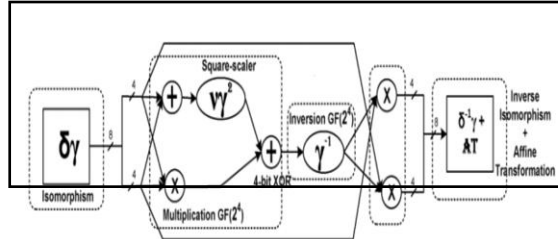


Figure 1. AES S-Box architecture.

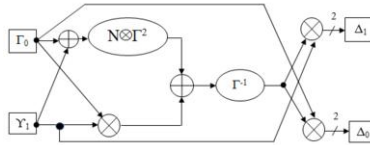


Figure 2. Normal GF  $(2^4)$  inverter.

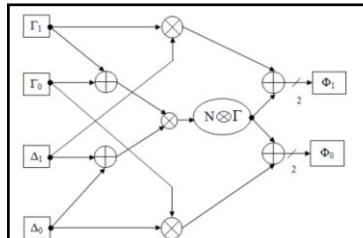


Figure 3. Normal GF  $(2^4)$  multiplier.

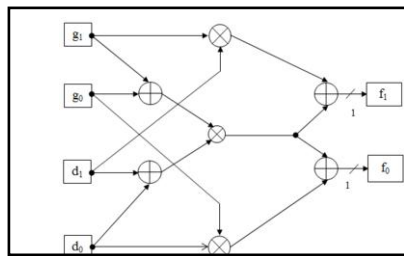


Figure 4. Normal GF  $(2^2)$  multiplier.

#### 4. Implementation of CFA S-box

Here, we discuss about the implementation of the proposed tiny AES S-box structures [5]. Two-phase process is used for area reduction in the substitution box. The important

issue while converting a ROM table into combinational circuit that should not increase the area of the circuit. To do this, the entire sub - operations in GF (2<sup>8</sup>) inversion can be translated exclusively into logical expressions.

Our proposed tiny Substitution byte and its inverse has 78 EX-OR gates and 36 AND gates. It is 20% lesser and faster than the earlier works. Both encryption and decryption uses Substitution box and substitution box inverse respectively. They comprised of affine transformations, isomorphism functions, inverters and multiplexer. Proposed architecture is smaller in size with 78 EX-OR gates and 36 AND gates. A tiny S-Box and S-Box<sup>-1</sup> was created by using composite field technique, integration the isomorphism functions with affine transformations, by means of a factoring technique, and merging the encipher and decipher routes.

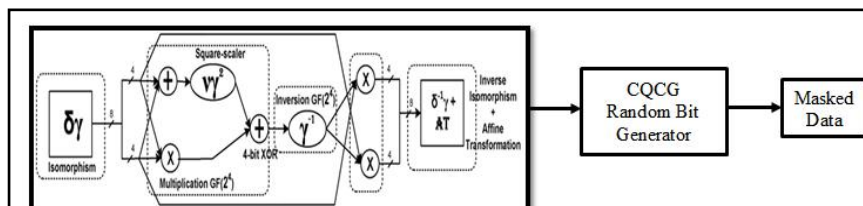
**Table 1.** Comparisons of hardware complexities

Work Done By	Total gates		Critical Path	
	AND	EX-OR	AND	
M.M.Wong	36	96	4	2
Canright	36	91	4	2
M.Lamberger	58	110	4	1
Edwin	36	85	4	2
This Work	36	78	4	2

Evaluations of the circuit complications among this paper and the nominated earlier papers are mentioned briefly in Table 1. Table 1 shows that, the comparisons of different hardware implementations. This paper deals with a decline of 25.12% in size when compared to the work done by M.M.Wong.

**5. Masked AES S-box**

Arithmetical investigations which use consumed power to perform the specific task or function, radiation emitted by the source to find data approximately [9].In order to avoid the mentioned analysis hiding the data by modulo-2 addition using random variables. There are two types of masking is possible. One is addition and another one is multiplication. The best suitable mask is modulo-2 addition. Because in multiplication mask, the data zero is not hidden. So, multiplication mask is not taken into account for masking purposes [7].



**Figure 5.** Architecture of the proposed system.

Figure 5 depicts the proposed architecture which is generating the substitution byte, random bit sequence using CQCG and produced a masked substitution byte as the output. Two QCG modules are coupled and their outputs are compared using particular

comparator scheme. Bits are extracted from the comparator using the output of the two coupled QCG modules. A coupled QCG (CQCG) output calculated by using,

$$\begin{aligned}
 a_{i+1} &= (P_1 a_i^2 + Q_1 a_i + R_1) \% m \\
 b_{i+1} &= (P_2 b_i^2 + Q_2 b_i + R_2) \% m
 \end{aligned}
 \tag{3}$$

$Y_{i+1}$  denotes the output bit of the coupled QCG,

$$\left. \begin{aligned}
 Y_{i+1} &= 1 && \text{if } a_{i+1} > b_{i+1} \\
 &0 && \text{otherwise}
 \end{aligned} \right\}
 \tag{4}$$

$P_1, Q_1, P_2, Q_2, R_1, R_2$  are assumed and  $a_0, b_0$  are considered as base values to calculate the random bit sequence using CQCG.

Consider  $P_1=13, Q_1=5, R_1=1, P_2=13, Q_2=7, R_2=3$ , And  $m=8. (a_0, b_0)=(7, 12)$ .

By using the equation 3, the output values of QCGs are calculated. They are random numbers. The output of two QCGs are given to comparator to produce the random bit sequence. If QCG1 output is greater than the QCG2 output means the random bit output is high else the output is low.

$$\{a_i\} = (1, 3, 5, 7, 1, 3, 5, 7), \{b_i\} = (7, 1, 7, 1, 7, 1, 7, 1)$$

The output bit sequence  $Y_i$  is (0, 1, 0, 1, 0, 1, 0, 1) generated by the CQCG for the above input. Consider the actual substitution byte that is added with random bit sequence to produce masked data. Two independent masks are added together yields another uniformly distributed mask. Each intermediate term distribution is not dependent of the data, hence the calculation becomes secure.

### 6. Hardware results

Here we take Spartan 3 FPGA board to implement the compact AES Substitution byte and its inverse without masking and compact masked AES Substitution byte and its inverse[6]. We take only 78 EX-OR Gates utilized to get the compact AES Substitution byte and its inverse, whereas Wong’s work took 96 EX-OR gates to implement the same.

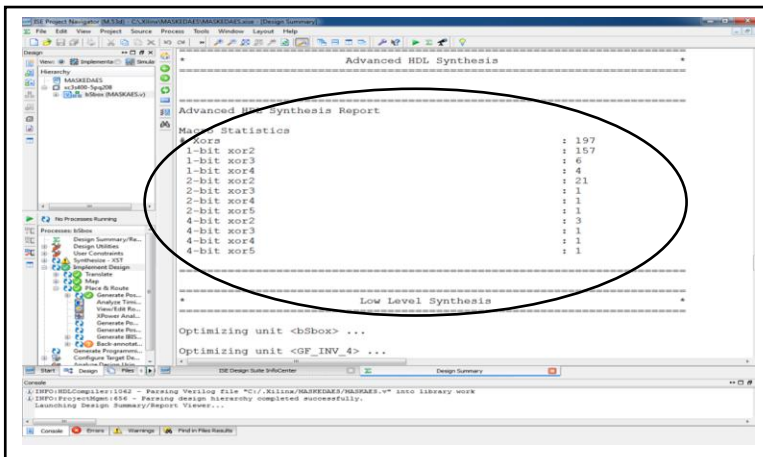


Figure 6. Masked AES Substitution byte and its inverse gate utilization.

Figure 6 shows the hardware utilization of the compact masked AES Substitution byte and its inverse. We take only 197 *EX-OR* Gates utilized to get the masked AES Substitution byte and its inverse, whereas can right's work took 234 *EX-OR* gates to implement the same.

## 7. Conclusion

The Substitution byte and its inverse of Advanced Encryption Standard is implemented with least complexity of combinational circuitry using FPGA. The chip area is significant in hardware restricted distinct devices [8]. The size reduction allows the merged Substitution byte and its inverse circuit to be suitable on a chip. Hence, the pipelined and high throughput AES process on smaller chips is obtained using FPGA. Our finest tiny substitution byte and its inverse uses 25.12% lesser than the previous. For various security applications, compact version of cryptographic algorithms are required. So, in future hardware implementations of AES, this tiny merged Substitution byte and its inverse is useful. The major role of this work was the implementation of merged AES Substitution byte and its inverse that achieves a balanced structure with optimized speed and size reduction. The best design obtained has a total of 78 *EX-OR* gates without masking and 197 *EX-OR* Gates to implement the Masked AES Substitution byte and its inverse. Circuit used for substitution byte and its inverse are implemented with the 18.853ns delay.

## References

- [1] Wong MM, WongMLD, NandiAK, HijazinI. Construction of Optimum Composite Field Architecture for Compact High-Throughput AES S-Boxes. *IEEE transactions on very large scale integration (VLSI) systems*.2012 June;20(6): 1151 – 1156.
- [2] Satoh A, Morioka S, Takano K, Munetoh S. A Compact Rijndael Hardware Architecture with S-Box Optimization. In: Boyd C. (eds) *Advances in Cryptology — ASIACRYPT*. Lecture Notes in Computer Science;2001;2248. Springer, Berlin, Heidelberg.
- [3] Rudra A, Dubey PK, Jutla CS, Kumar V, Rao JR, Rohatgi P. Efficient Rijndael Encryption Implementation with Composite Field Arithmetic. In: Koç ÇK, Naccache D, Paar C (eds). *Cryptographic Hardware and Embedded Systems — CHES 2001*. CHES 2001. Lecture Notes in Computer Science, vol 2162. Springer, Berlin, Heidelberg.
- [4] DeshpandeAM, DeshpandeMS,KayatanavarDN. FPGA implementation of AES encryption and decryption. *International Conference on Control, Automation, Communication and Energy Conservation*:2009; Perundurai, India: p. 1-6.
- [5] Canright David,BatinaLejla. A Very Compact Perfectly Masked S-Box for AES. *IACR Cryptology ePrint Archive*; 2009; 11.
- [6] Edwin NC Mui. Practical Implementation of Rijndael S-Box Using Combinational Logic.Texco Enterprise Ptd. Ltd Technical report; 2007.
- [7] Daemen J, Rijimen V. *The Design of Rijndael*. Springer-Verlag; 2002.
- [8] Wolkstorfer J, Oswald E, Lamberger M. An ASIC Implementation of the AES S-Boxes. In: Preneel B. (eds) *Topics in Cryptology —CT-RSA 2002*. Lecture Notes in Computer Science; 2271; Springer, Berlin, Heidelberg.
- [9] MassoudMasoumi. A Novel and Highly Efficient AES Implementation Robust against Differential Power Analysis. K. N. Toosi University of Tech., Tehran, Iran.
- [10] WongMM, WongMLD, NandiAK,Hijazin I. AES s-box using Fermat's little theorem for the highly constrained embedded devices. 20<sup>th</sup>European Signal ProcessingConference; 2012.
- [11] Naga M Kosaraju, Murali Varanasi,Saraju P. Mohanty. A High-Performance VLSI Architecture for Advanced Encryption Standard (AES) Algorithm. University of North Texas Denton, TX 76203; 2008.
- [12] NIST. Announcing the Advanced Encryption Standard (AES). Technical Report FIPS Publication 197, National Institute of Standards and Technology (NIST); 2001 November.

# An Effective Denoising and Enhancement Strategy for Medical Image Using Rl-Gl-Caputo Method

M .Ganga<sup>a,1</sup>, N.Janakiraman<sup>b</sup>, Arun Kumar Sivaraman<sup>c</sup>, Rajiv Vincent<sup>c</sup>, A.Muralidhar<sup>c</sup> and Priya Ravindran<sup>d</sup>

<sup>a,1</sup>Research Scholar, K.L.N. College of Engineering, Madurai, India

<sup>b</sup>Professor Dept of ECE, K.L.N. College of Engineering, Madurai, India

<sup>c</sup>Assistant Professor, School of CSE, VIT University, Chennai, India

<sup>d</sup>Project Manager, HCL Technologies, Chennai, India

**Abstract.** At present, fractional differential is the effective mathematical approach which deals with the factual problems. This projected technique employs the fractional derivatives definitions Riemann-Liouville (R-L), Grunwald-Letnikov (G-L) and the caputo technique for denoising medical image. The presented method based on fractional derivative which in turn improves the quality of image. The input image is processed on integer order method such as pre-processing operation, image conversion and noise image. The fractional differential mask method is to be applied with the help of Riemann Liouville, and Caputo algorithm. After denoising the medical image enhanced using Anisotropic diffusion process and the result is analyzed to finally get denoised and predicted image.

**Keywords.** Medical image, denoising, enhancement, Riemann-Liouville (R-L), caputo, Grunwald-Letnikov (G-L), anisotropic diffusion.

## 1. Introduction

In image processing systems, image denoising, and image enhancement is an indispensable problem however it is not easy to examine. The effectual means of making a convolution mask which is fractional-dependent will be based on image denoising and image enhancement mechanism which is capable of recognizing edges quite significantly in detail [1]. The fractional derivatives benefits are obvious in engineering correspondence that covers automatic manipulate, biomedical programs, finite impulse reaction filter designs, and in lots of other fields [2, 3]. Noise is signified as any unwanted signal which in turn contaminates an image.

---

<sup>1</sup>Ganga M, Research Scholar, K.L.N. College of Engineering-Madurai, India;  
Email: ganga4507ashwin@gmail.com



Image denoising inside the fractional area has lately obtained extensive research attention [4, 5]. Several algorithms on fractional calculus for image denoising were proposed [6, 7]. On the contrary the property of integral differential, the constant fractional differential is non-zero, while their integral differential should be a zero one [8, 9]. Fractional differential be capable of enhancing the intricate textural information of images nonlinearly [10, 11]. Here in this method a fractional differential mask approach using RL-SG method was implemented. Riemann liouville and SavitzkyGolay algorithm helps to develop the sense of the fractional operators. It helps to evaluate the numerical derivatives which are also known as digital smoothing polynomial filter. This method helps to reduce the noise effect and it should be helps to apply the particular region by the separation of the whole area. The residual part of the manuscript is systematized as shown: the section II is a depiction of several presented method that is employed so far. Section III is the narration of projected method. The performance outcome of the projected system is shown in section IV. At last, the conclusion of proposed system is offered in section V.

## 2. Related Works

[12]deliberated a novel hybrid method for despeckling, depending on Undecimated Dual-Tree Complex Wavelet Transform 5 (UDT-CWT) with the use of MAP (maximum a posteriori) estimator and non-local Principal Component Analysis (PCA)-based filtering by the local pixel grouping (LPG-PCA). DT-CWT is a newly formed transform which offer both near shift invariance and enhanced properties of directional selectivity. [13] considered an effective method of Discrete Wavelet Transform (DWT) for the analysis of EEG time-frequency and were employed for detection of seizure in the daily monitoring systems of healthcare. DTDWT might conquer those drawback however might augment redundancy of information [14].At present, the image denoising depending on sparse representation has a superior outcome [15]. a new framework of wavelet denoising depending on sparse depiction was presented. This technique offers an optimal resolution in assured circumstances through orthogonal matching pursuit (OMP), the algorithm of steepest descent, or else the algorithm of conjugate gradient. [16] proposed an algorithm to enhance vessels which is based on Hessian matrix. In this work, to improve the detection of arteries on coronary angiograms a variation in an algorithm. [3] proposed algorithm utilizes the fractional derivatives (R-L) and (G-L) definitions in the estimation of two direction areas and enhancement of image in the course of first run. As per this, new Gabor filter mask fractional derivative is intended.

## 3. Proposed work

This part offers the comprehensive representation of proposed methodology.The overall flow of the projected system is shown below:

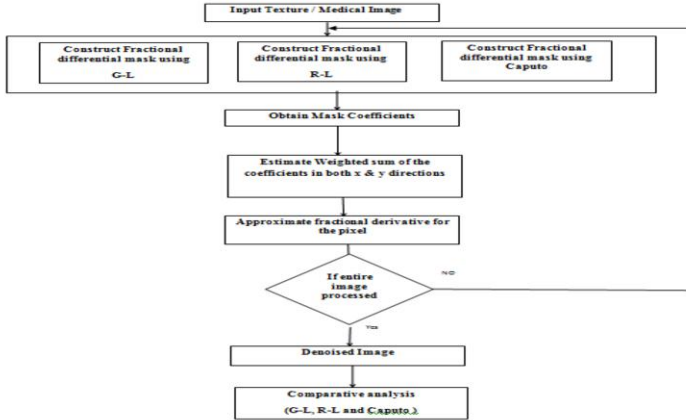


Figure 1. Flow of proposed system

### 3.1 Fractional differential mask

A convolution mask that is fractional-dependent having the application to the edge analysis of the image was being made. The mask was made depending on derivative Riemann-Liouville fractional that was considered as a particular Srivastava-Owa operator form. The fractional differential known as RL, and GL, six fractional differential masks were presented and offered the parameters and structures of all cover on the direction of positive x-coordinate, negative x-coordinate, negative y-coordinate, positive y-coordinate, right downward diagonal, right upward diagonal, left downward diagonal, and left upward diagonal correspondingly.

The coefficient of the fractional differential operator mask is provided by:

$$\left\{ \begin{array}{l} C_{s0} = 1 \\ C_{s1} = -v \\ \vdots \\ C_{sk} = \frac{\Gamma(k-v)}{k! \Gamma(-v)} \\ \vdots \\ C_{sn-1} = \frac{\Gamma(n-v-1)}{(n-1)! \Gamma(-v)} \\ C_{sn} = \frac{\Gamma(n-v)}{n! \Gamma(-v)} \end{array} \right. \quad (1)$$

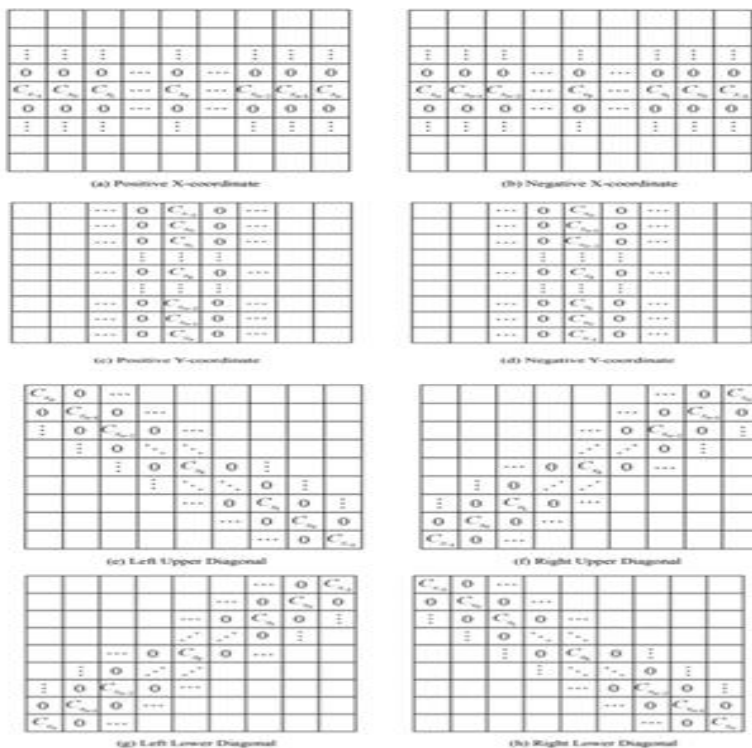


Figure 2. Fractional differential mask on the eight directions

The fractional differential is the normally used one for enhancing the edge and texture details of medical image in the digital image processing. RL – GL-Caputo method in turn associated with a real function  $f : \mathbb{R} \rightarrow \mathbb{R}$  another function  $I_a f$  of the correlated kind in support of the entire parameter value  $\alpha > 0$ . The integral is a generality behavior of the recurring anti-derivative of  $f$  for positive integer values of  $\alpha$ ,  $I_a f$  was an anti-derivative iteration of  $f$  of the order  $\alpha$ . Three popular designation of fractional operators calculus are specified by G-L, Caputo, and R-L. Among these, G-L and R-L are the most admired designation employed in processing digital image.

The G-L significance of  $\alpha > 0$  fractional order derivative is characterized as:

$${}_a D_t^\alpha = \lim_{h \rightarrow 0} h^{-\alpha} \sum_{j=0}^{\lfloor \frac{t-a}{h} \rfloor} (-1)^j \binom{\alpha}{j} f(t - jh), \tag{2}$$

Where, the binomial coefficients are  $\alpha_j$ .

The Riemann – Liouville integral is defined by,

$$I^{\alpha} f(x) = \frac{1}{\Gamma(\alpha)} \int_a^x f(t)(x-t)^{\alpha-1} dt \tag{3}$$

where  $\Gamma$  is Gamma function and  $a$  is the arbitrary however base point that is fixed.

Obviously  $I^1 f$  is the anti-derivative of  $f$  (of first order), and on behalf of positive integer values of  $\alpha$ ,  $I^{\alpha} f$  was an anti derivative of order  $\alpha$  through formula Cauchy meant for frequent integration.

The area of the incidence rectangle in lower bound is given by,  
 Lower (par, func) =

$$m_1(x_1 - x_0) + m_2(x_2 - x_1) + \dots + m_n(x_n - x_{n-1}) = \sum_{j=1}^n m_j(x_j - x_{j-1}) \tag{4}$$

The area of the incidence rectangle in upper bound is given by,  
 Upper (par, func) =

$$m_1(x_1 - x_0) + m_2(x_2 - x_1) + \dots + m_n(x_n - x_{n-1}) = \sum_{j=1}^n m_j(x_j - x_{j-1}) \tag{5}$$

Here, Par is the partition, func is the function, Inferimum is denoted as  $m_j$ , superimum is denoted as  $M_j$ .

A standard approach is to utilize diffusion for image smoothing is anisotropic diffusion . After that, process of linear isotropic diffusion might be well-defined through the below equation

$$\frac{\partial L}{\partial t} = \nabla \cdot (c \nabla L) = c \nabla^2 L. \tag{6}$$

Let  $L(x,y)$  signify a grayscale noisy input image and  $L(x,y;t)$  be an image evolving at  $t$  scale , initialized by  $L(x,y;0)=L(x,y)$ .

#### 4. Performance Analysis

In fact, in acquisition of image, one will frequently suppose that the resultant image might be contaminated by a number of unrestrained features. Be that as it may, evidently an ability of algorithms for handling these features will make them invariant and robust creation of their implementation useful.

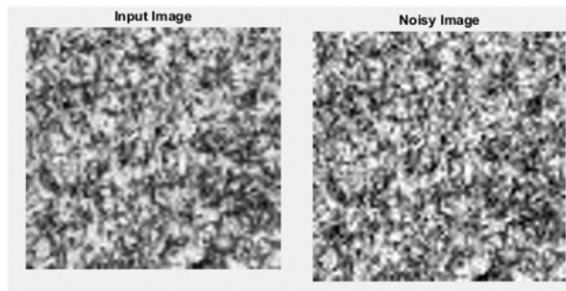
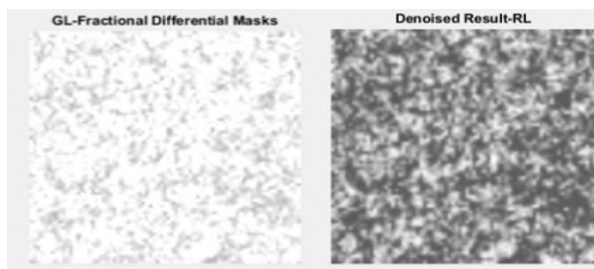


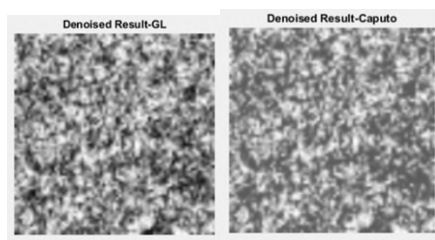
Figure 3. Input image      Figure 4. Noisy image

Figure 3 and figure 4 is the representation of input image and noisy image which is added to get better result.



**Figure 5.** GL-Fractional differential masks **Figure 6.** Denoised Result-RL

Figure 5 is the depiction of GL-Fractional differential masks which is attained by the use of GL method at the noisy image. Figure 6 is the denoised result attained on the use of RL method. The noisy image is denoised using RL method.



**Figure 7.** Denoised Result-GL **Figure 8.** Denoised Result-Caputo

Figure 7 is the denoised result attained on the use of GL method. Figure 8 is the denoised result attained on the use of Caputo method.

## 5. Conclusion

A new medical image denoising and method of enhancement was presented using RL-GL-Caputo method. After denoising the image is enhanced using anisotropic diffusion enhancement technique. The projected technique considered the neighboring information (like the image edge, texture information and clarity) and structural features of various pixels, in addition to the directional derivative of all pixel in the construction of masks. By means of presenting this process, it not only can enhance the information of high frequency, however also enhance the information of low frequency of the image. Eventually, this in turn augments the information regarding texture of the medical image.

## References

- [1] Zhang,X, Image denoising using local Wiener filter and its method noise,Optik, vol. 127, pp. 6821-6828, 2016.
- [2] H. A. Jalab, R. W. Ibrahim, and A. Ahmed, Image denoising algorithm based on the convolution of fractional Tsallis entropy with the Riesz fractional derivative, Neural Computing and Applications, vol. 28, pp. 217-223, 2017.
- [3] Baloochian,H, Ghaffary,H.R, and S. Balochian.Enhancing fingerprint image recognition algorithm using fractional derivative filters,Open Computer Science, vol. 7, pp. 9-16, 2017.
- [4] J. Ji, Y. Xiao, Y. Xu, W. Deng, J. Yang, Y. Wang, et al., A denoising method of medical ultrasound image based on guided image filtering and fractional derivative, in Optoelectronic Imaging and Multimedia Technology V, 2018, p. 108170B.
- [5] B. Ghanbari and A. Atangana, A new application of fractional Atangana–Baleanu derivatives: Designing ABC-fractional masks in image processing, Physica A: Statistical Mechanics and its Applications, vol. 542, p. 123516, 2020.
- [6] Q. Wang, J. Ma, S. Yu, and L. Tan, Noise detection and image denoising based on fractional calculus, Chaos, Solitons & Fractals, vol. 131, p. 109463, 2020.
- [7] H. Jalalinejad, A. Tavakoli, and F. Zarmehi, A simple and flexible modification of Grünwald–Letnikov fractional derivative in image processing, Mathematical Sciences, vol. 12, pp. 205-210, 2018.
- [8] T. Pingping, C. Wen, X. Feng, and D. Yan, Multi-source information fusion image denoising method based on fractional modeling, in 2017 Chinese Automation Congress (CAC), 2017, pp. 7282-7286.
- [9] S. Kumar, R. Saxena, and K. Singh, Fractional Fourier transform and fractional-order calculus-based image edge detection, Circuits, Systems, and Signal Processing, vol. 36, pp. 1493-1513, 2017.
- [10] B. Li and W. Xie, Image denoising and enhancement based on adaptive fractional calculus of small probability strategy, Neurocomputing, vol. 175, pp. 704-714, 2016.
- [11] Mokhtari,R and F. Mostajeran, A High Order Formula to Approximate the Caputo Fractional Derivative, Communications on Applied Mathematics and Computation, vol. 2, pp. 1-29, 2020.
- [12] R. Farhadiani, S. Homayouni, and A. Safari, Hybrid SAR Speckle Reduction Using Complex Wavelet Shrinkage and Non-Local PCA-Based Filtering,IEEE Journal of Selected Topics in Applied Earth Observations and Remote Sensing, vol. 12, pp. 1489-1496, 2019.
- [13] M. Saeedzarandi, H. Nezamabadi-pour, and A. Jamalizadeh, Dual-Tree Complex Wavelet Coefficient Magnitude Modeling Using Scale Mixtures of Rayleigh Distribution for Image Denoising,Circuits, Systems, and Signal Processing, pp. 1-26, 2019.
- [14] X. Jiang, K. Xu, R. Zhang, H. Ren, and W. Chen, Redundancy Removed Dual-Tree Discrete Wavelet Transform to Construct Compact Representations for Automated Seizure Detection, Applied Sciences, vol. 9, p. 5215, 2019.
- [15] Singh,K, S. K. Ranade, and C. Singh, Comparative performance analysis of various wavelet and nonlocal means based approaches for image denoising,Optik, vol. 131, pp. 423-437, 2017.
- [16] Martínez-Jiménez,L, J. Cruz-Duarte, J. Rosales, and I. Cruz-Aceves, Enhancement of Vessels in Coronary Angiograms Using a Hessian Matrix Based on Grunwald-Letnikov Fractional Derivative, in Proceedings of the 2018 8th International Conference on Biomedical Engineering and Technology, 2018, pp. 51-54.
- [17] Ambeth Kumar.V.D et.al, .Enhancement in Footprint Image using Diverse Filtering Technique Procedia Engineering journal, Volume 8, No.12, 1072-1080, 2012 . [doi:10.1016/j.proeng.2012.01.965]
- [18] Ambeth Kumar.V.D,Ashok Kumar V.D,Malathi.S and Jagaedesh.P, (2014). Intruder Identification using Footprint Recognition with PCA and SVM Classifiers for the International Journal of Advanced Materials Research Vols.1345, PP 984-985 (2014) pp 1345-1349. [DOI:10.4028/www.scientific.net/AMR.984-985.1345]
- [17] Ambeth Kumar.V.D et.al. . A Survey on Face Recognition in Video Surveillance. Lecturer Notes on Computational and Mechanism, Vol. 30, pp: 699-708, 2019

# Design and Performance Analysis of Low Power High Speed Adder and Multiplier Using MTCMOS in 90nm, 70nm, 25nm and 18nm Regime

Kalpana.K<sup>a</sup>, Paulchamy. B<sup>a,1</sup>, Priyadharsini. R<sup>b</sup>, Arun Kumar Sivaraman<sup>b</sup>, Rajiv Vincent<sup>b</sup>, A. Muralidhar<sup>b</sup> and Kong Fah Tee<sup>c</sup>

<sup>a,1</sup>Dept of ECE, Hindusthan Institute of Technology, Coimbatore, India

<sup>b</sup>School of Computer Science and Engineering, VIT University, India

<sup>c</sup>School of Engineering, University of Greenwich, United Kingdom

**Abstract.** Nowadays, VLSI technology mainly focused on High-Speed Propagation and Low Power Consumption. Addition is an important arithmetic operation which plays a major role in digital application. Adder is act as an important role in the applications of signal processing, in memory access address generation and Arithmetic Logic Unit. When the number of transistors increases in system designs, makes to increase power and complexity of the circuit. One of the dominant factors is power reduction in low power VLSI technology and to overcome the power dissipation in the existing adder circuit, MTCMOS technique is used in the proposed adder. The design is simulated in 90nm, 70nm, 25nm and 18nm technology and then comparison is made between existing and proposed system in the context of energy, area and delay. In this comparison, the efficiency metrics power and delay are found to be reduced 20% from the existing adder and the proposed adder is used for the design of low power multiplier.

**Keywords.** Multiplier, Adder, Power Consumption, VLSI Technology, Low power, (MTCMOS) Multi-threshold Complementary Metal Oxide Semiconductor

## 1. Introduction

In digital systems, some kind of digital circuits are largely used to execute addition of figures. It also forms the basis of division, multiplication and subtraction. Addition is the basic operation for analyzing any digital systems discussed in [3]. Power utilization increases, as no of transistor increases. So, the primary needs in the VLSI design are low power design. For emerging low power and high-speed IC fabrication, the deep submicron technologies are used as challenging criteria analyses in [4]. From our references, hybrid adder model is one of the heuristic approaches for power reduction with less transistor counts. For our literature survey, in [12] analyzed numerous adders with performance parameters are achieve the numerous areas, power and speeds

---

<sup>1</sup>Kalpana K, Dept of ECE, Hindusthan Institute of Technology, Coimbatore, India;  
Email: kalpanak@gmail.com

necessities for implementation. Researchers mainly focus to plan a well-organized arithmetic circuit that one works with greater speed and low power in the Power rakishness mainly hang on the substituting action, wire and node capacitances along with size of the control circuit [2]. Full adder is one of the fundamental digital circuits that make addition. Full adders are executed with logic gates in hardware. There are two types in full adders they are static and dynamic full adders [5]. Static adder has no static power dissipation, rail to rail swing, the speed of the circuit relied on the transistor sizing and different parasitic that are involved in with it and the signal been swings in static adder all the way to supply [19]. Voltage levels are both the positive and negative rails, no invariable potential dissolution. The transistor sizing and different dependents that are mixed up in with it's based on speed of the circuit. The issue with is kind of execution is that for  $N$  fan in circuit  $2N$  number of transistors are required i.e., more area is wanted to get applied [13].

## 2. Materials and Methods

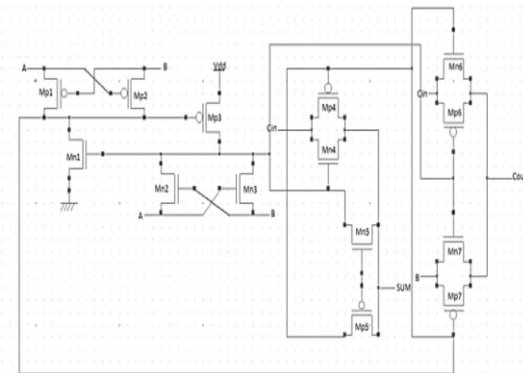
From the literature survey, we observed some logic styles with positive and negative side are given below. Dynamic CMOS has a main advantage of increased speed and reduced implementation area [8]. The number of transistors required here are less  $(N+2)$  as compared to  $2N$  in the static CMOS circuits. Dynamic logic circuit has less loss in static power. But it needs clock for the proper operation. Based on clock, it consumes more power and more complexity than static circuit. In dynamic CMOS logic certain additional power is spent when the circuit has to precharged after every evaluation [12]. Static CMOS logic is one of the logics, which does not require clock. The output will be as soon as the inputs are probed (without considering the propagation delay of the circuit). This logic is contrast to dynamic CMOS which relies on the temporary storage of signal using various load capacitances [11]. The different logic styles include in static CMOS logic are Pseudo NMOS logic, Broadcast logic and Authorization transistor lucidity etc. The Pseudo NMOS logic can be developed by only one PMOS with always ON condition and N-block for logic implementation [11]. Fast switching operations and less transistor count are the advantages of pseudo NMOS logic. This logic has more static power dissipation due to the use of pull up devices, reduction in voltage levels and gain. These reasons this logic makes more vulnerable to noise. So, the Pseudo NMOS logic gives more speed with less static power consumption than static design of circuits [7]. Pass transistor logic narrate the numerous logical operations used in the plan of integrated circuits. By removing redundant transistors, it minimizes the computation transistors used to build different logic gates [14]. It uses few transistors, runs faster; require less power than in CMOS logic. The sum of dynamic plans implemented in pass transistor logic but it has the disadvantages that the dissimilarity of the voltage between high and low logic levels reduces at each phase. Every device in sequence is a lesser amount of soaked at its output then at its input [10]. A commonly raised gate may be essential to replace the signal voltage to the full value, if some devices are connected in sequence in a logic track. By dissimilarity, standard CMOS logic transistors show the output joins to the power supply rails, so that in sequential chain the logic voltage stages does not decreases. This has an impact on capacitance and speed of the circuit. Dynamic adder relies on the temporary storage of signal value on the capacitance. This type also has no static power dissipation and uses a sequence of charging and discharging with the addition of the clock input. The



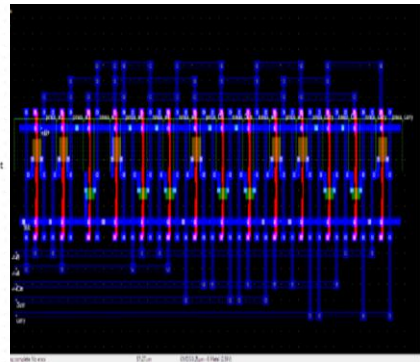
main advantages of this type are increased speed and reduced realization area. In this article we design a high speed adder using MTCMOS technology. The proposed structure analyzed in various nanometer technologies. The technologies are 90nm, 70nm, 25nm and 18nm technology and to present the comparison is made between existing and proposed system in terms of area, power and delay. In this comparison, the efficiency metrics like power and delay is found to be reduced 20% from the existing adder and the proposed MTCMOS Low power adder. And this proposed design can be implemented in array multiplier circuit.

### 2.1. Existing method of full adder

The existing full adder circuit is presented by [9] as shown in Fig.1 is comprise of individual 14 transistors and divided into three components. Module 1 represent the XNOR module, Module 2 along with Module 3 represent the Transmission gate Component which generates Sum and  $C_{out}$  signal respectively. The XNOR Module is constructed using 6T (6 transistors) to eliminate the threshold voltage drop in the module. This module is built on the cross joined PMOS arrangement, and it correspondingly utilize the cross joined NMOS arrangement to create the pair. For the combination of  $A=B=0$  and  $A=B=1$  are processed by the feedback MOSFETs. The gateway voltage loss connected with circuit is also eliminated. This feedback lowers the maximal operating frequency and when compared with other XNOR gates. It also provides the full voltage swing analyzed in [9].



**Figure 1.** Existing Full adder presented

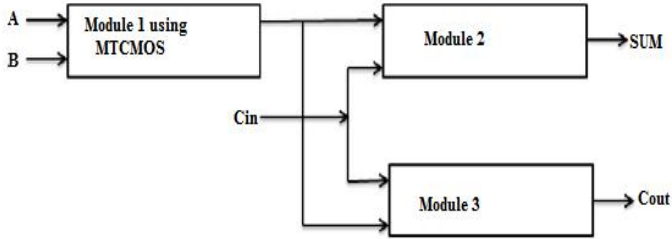


**Figure 2.** Layout of the existing full adder

The second module sum is constructed and to reduce the power to practicable extends. In this second module XOR gate designed based on transmission gate [6]. The input to this module is given from the output of the first module. This design is not allowed any rail of power or ground. It's a main reason for the absence of short circuit and low power dissipation. But the drawback of this module is not capable of driving bigger loads. The third component is constructed by means of transmission gate logic as shown in the Fig 1. This module is fundamentally a multiplexer which passes either A (or B) or  $C_{in}$ , as per the rate of the output of the first module. The input signal A and  $C_{in}$  delivers the pouring control for this module, then whichever of the signal will pass. This design is used to avoid lacking power of  $C_{out}$  signal in which a key or buffer tracks

the output of the adder cell. In Fig.2 is shown as layout for the existing full adder presented in [10].

## 2.2. Proposed method of full adder



**Figure 3.** Block diagram of the proposed full adder

The XOR module is still provides power even when it does not give output since it does not produce output for input  $A=B=0$  and  $A=B=1$ . This will contribute to the total power consumption of the circuit. In chip design one of the greatest technologies is CMOS which is commonly used today to construct integrated circuitry in numerous submissions. CMOS technology is quite appropriate skill for numerous mechanisms in memories, microprocessors and microcontroller applications. It has negligible static power dissipation. Energy dissipation is an acute parameter in VLSI circuits as a result of systematic shrinkage in dimension of CMOS circuits. Excess power usages in VLSI circuit require excessive wrapping and freezing systems that makes it the cost and reduces the system reliability. MTCMOS is named as Multi-threshold Complementary Metal Oxide Semiconductor. An efficient method to handle power dissipation is scaling the supply voltage. MTCMOS technique is a powerful circuit-level technique which provides low power consumption and high performance by using sleep transistors. This low power technique maintains the circuit efficiency while dropping the sub threshold current in standby mode [13].

An unavoidable thing in VLSI is power management as the automation lies down, so the low-power method should be used to minimize power dissolution. There is multiple origin of power dissipation in digital circuits such as switching activities and short circuit current of the circuit and the other one is due to leakage current. High leakage current is converted into an essential contribution to power dissipation of CMOS circuits [12]. MTCMOS is the low power design which is employed to decrease the power utilization. Generally standby currents, as prime reason of power loss, it can be reduced by using MTCMOS technique [16]. In this approach the use of sleep transistors to increase speed at low supply voltage with low power dissipation.

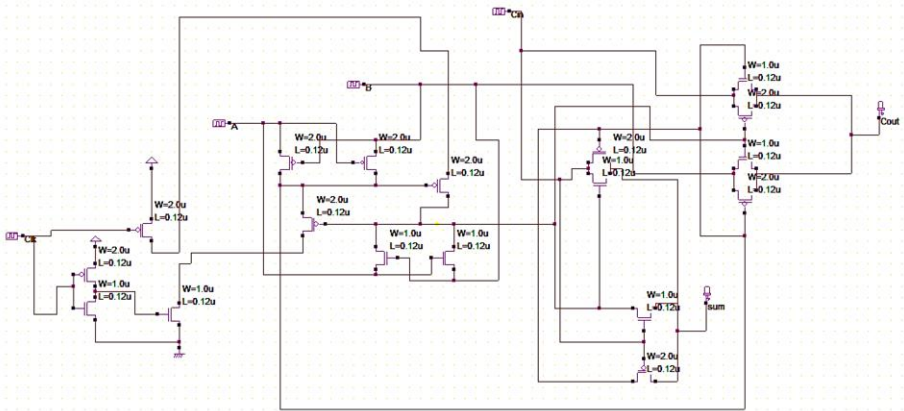


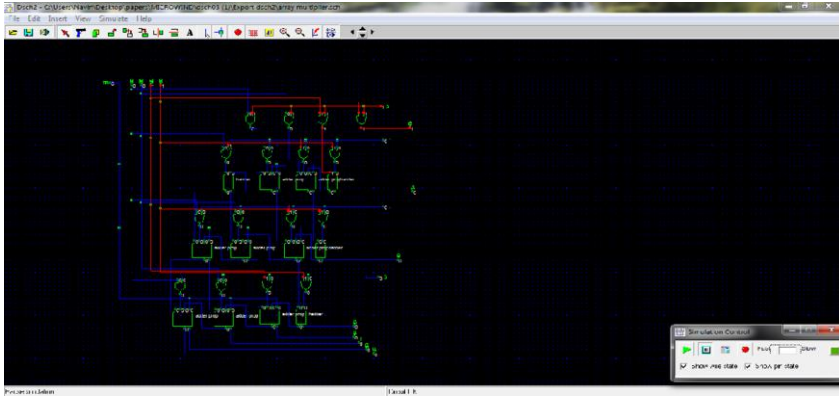
Figure 4. Circuit diagram of proposed full adder

In the submitted plan of adder using MTCMOS technology has 18T (18 transistors with 9 PMOS and 9 NMOS) as presented in the Fig.4. In Fig.3 shows the functional block diagram for the proposed adder. In the suggested design of adder using MTCMOS gives less mean power consumption as estimated to the standard design of circuit. The main reason for the reduction of average power dissipation of the circuit is Sleep transistors. Sleep signals in sleep transistors are used to enable the transistor. In this logic uses two types of threshold transistors with high and low value. In standby mode the High threshold transistors are act as sleep transistor to reduce power consumption. In active mode the Low threshold transistors are used to increase the performance of the circuit. Also High threshold transistor is linked in the middle of logic circuit and power supply. This technique is used to reduce the sub-threshold leakage during standby mode. For low power and high speed applications one of the efficient technique is MTCMOS. The main task during designing a circuit using MTCMOS is sizing of the transistor.

The proposed adder circuit was simulated on SPICE Tool with 90nm, 70nm, 25nm and 18nm technology. The layout for the proposed full adder is done in various nanometer regimes. The performance matrices are taken from the layout of all nanometer regimes. The comparison of MTCMOS technique with conventional technique used in adder circuit in terms of area, power and delay.

### 3. Results and Discussion

The complete adder strategy in Fig.1 was employed in 90nm, 70nm, 25nm and 18nm by means of SPICE package. Then the transient examination is attained for existing and proposed methods in 90nm, 70nm, 25nm and 18nm regions. The performance analysis of compared with existing systems. Generally power utilization divided into three major types like static, dynamic and leakage power dissipation. Dynamic power dissipation is one of the major reasons for power consumption. In CMOS circuits the Static power dissipation is resulted by leakage and biasing currents. Generally this is lesser than the dynamic power dissipation. It arises due to charging and discharging of load capacitances. In this work we analyze power dissipation in various nanometer technologies. Transient analysis was found for the proposed adder with 90nm and 70nm technology.



**Figure 5.** The proposed array multiplier by using the proposed MTCMOS full adder

One of the applications of full adder is multiplier. Multiplier is one the important block in arithmetic logic unit for various operations. It is used in signal processing applications, microprocessor applications and data manipulation function etc. [15]. So today, the design of multiplier with less power is most important role. In this paper to design a multiplier by using the proposed MTCMOS Full adder is implemented in Fig.5 and power, delay are compared. The simulation result for the planned multiplier was found. The comparative results of the proposed adder are given below. The existing adder in [9] is analyzed in 90nm, 70nm, 25nm and 18nm regime. The analysis factors are area, power and delay are done and the parameters are compared to the proposed one. In proposed adder for 90nm technology, the circuit functioned at 0.9v the entire power feasting was recognized to be 18.215 $\mu$ W, for 70nm technology, it was found to be 11.46 $\mu$ W, for 25nm technology, it was found to be 7.78 $\mu$ W and for 18nm technology, it was found to be 3.57 $\mu$ W. The delay is also one of the major parameter in analysis. The delay was found for the proposed full adder in various nanometer technologies are to be 206.78ps for 90nm, 198.07psfor 70nm, and 150.92psfor 25nm and112.23ps for 18nm technology. The adapted full adder is realized in Fig.4. It is recognized that the typical power feasting for the proposed MTCMOS full adder in 90nm technology is 16.64 $\mu$ W, for 70nm technology is 8.21 $\mu$ W, for 25nm technology is 5.23 $\mu$ W and for 18nm technology is 1.72 $\mu$ W. This reduced power feasting is primarily due to nonappearance of outflow current. The comparison is made by various parameters of the proposed full adder and multiplier was compared in Table-1 and Table 2.

**Table 1.** Comparison matrices for the proposed full adder in various nanometer regimes

Technology	90nm			70nm			25 nm			18nm		
Metric	Area (Sq.m)	Power ( $\mu$ W)	Delay (pS)	Area (Sq.m)	Power ( $\mu$ W)	Delay (pS)	Area (Sq.m)	Power ( $\mu$ W)	Delay (pS)	Area (Sq.m)	Power ( $\mu$ W)	Delay (pS)
<b>Existing [9]</b>	350	18.22	206	140	11.46	198	96	7.78	150	66	3.57	112
<b>Proposed</b>	517	16.64	190	297	8.21	170	210	5.23	130	174	1.72	94

**Table 2.** Comparison Results of various matrices in existing and proposed Multiplier

Technology	90nm			70nm		
Metric	Area (Sq.m)	Power ( $\mu$ W)	Delay (pS)	Area (Sq.m)	Power ( $\mu$ W)	Delay (pS)
<b>Multiplier using Existing adder</b>	4294	69.244	46	3387	56.739	38
<b>Proposed Multiplier using Proposed adder</b>	5544	39.222	41	4472	36.722	34

#### 4. Conclusion

In this research, a modified Full Adder is executed in 90nm, 70nm, 25nm and 18nm technology. Both the actual and planned Adder strategies were replicated by means of SPICE Tool. It is recognized that the power and postponement is condensed by the usage of MTCMOS technique was found to be for 90nm technology, the circuit functioned at 0.9v the overall power consumption was found to be  $18.215\mu$ W, for 70nm technology, it was found to be  $11.46\mu$ W, for 25nm technology, it was found to be  $7.78\mu$ W and for 18nm technology, it was found to be  $3.57\mu$ W. Also the power and delay of the proposed multiplier was found  $39.22\mu$ W for 90nm technology and  $36.722\mu$ W for 70nm technology. The Power, Delay and Area of both existing and proposed designs are measured and it is observed that power and delay are minimized in the case of the anticipated adder strategy. The extent of the anticipated adder design is increased. In this comparison, the performance metrics like power and delay is found to be reduced 20% from the existing adder and the proposed adder and is used for low power multiplier.

#### References

- [1] Abu-Shama, E. & Bayoumi, M. A new cell for low power adders. Proc. Int. Midwest Symp. Circuits and Systems, 1995,p.1014–1017.
- [2] Aranda.M.L, Baez.R, and Diaz.O.G, Hybrid adders for high-speed arithmetic circuits: A comparison, in Proc. of IEEE Int. Conf. Elect. Eng. Comput. Sci. Autom. Control (CCE), Tuxtla Gutierrez, NM, USA, 2010.p.546–549.
- [3] Blair.G.M,Designing low-power CMOS, Inst. Elect. Eng. Electron. Commun. Eng. J., 1994,6,p.229–236.
- [4] Devadas.S and Malik.S,A survey of optimization techniques targeting low-power VLSI circuits, In Proc. 32nd ACM/IEEE Design Automation Conf., San Francisco, CA, 1995,p.242–247.
- [5] Goel.S, Elgamel.M.A and Bayoum.M.A, Design Methodologies for High-Performance Noise-Tolerant XOR–XNOR Circuits, IEEE Transl. on Circuits and Systems—I, 2006,53( 4).
- [6] Hung Tien Bui, Yuke Wang, and Yingtao Jiang,Design and Analysis of Low-Power 10-Transistor Full Adders Using Novel XOR–XNOR Gates, IEEE Transactions On Circuits And Systems—II: Analog And Digital Signal Processing, 2002,49(1).
- [7] I.S. Abu-Khater ,A. Bellaour and Elmasry.M.I,Circuit techniques for CMOS low-power high performance multipliers, IEEE J.Solid-State Circuits,1996,31,p.1535–1544.
- [8] O. J. Bedrij, Carry-select adder,” IRE Transactions on Electronic Computers, vol. EC-11,1962, 3, p. 340–346.
- [9] Partha Bhattacharyya, Bijoykundu, Sovanghosh, Vinay Kumar And Anupdandapat,Performance Analysis of a Low-Power High- Speed Hybrid 1-bit Full Adder Circuit, IEEE Very-large-scale integration (VLSI),2014.
- [10]Pinninti Kishore,Sridevi.P.V,Babulu.K,Low Power and Optimized Ripple Carry Adder and Carry Select Adder Using MOD-GDI Technique, Proceedings of Microelectronics, Electromagnetics and Telecommunications, Lecture Notes in Electrical Engineering, Springer India ,2016,P.159-171.
- [11]Prashanth.P and Swamy.P,Architecture of adders based on speed, area and power dissipation,In Proc.World Congr. Inf. Commun. Technol. (WICT),2011,p.240–244.
- [12]Preetiagraval, Anjan Kumar and Manishapattanaik,Diode based Multi-Mode MTCMOS 8T Adder for Wake up Noise Minimization in 90nm CMOS Technology, IEEE Very-large-scale integration(VLSI),2017.

- [13] Qiang Zhou, Xinzhao, Yicicai, Xianlonghong, An MTCMOS technology for low-power physical design, Integration, the VLSI journal, 2009,42,p.340–345.
- [14] Rajkumar Sarma And Veerati Raju, Design and Performance Analysis of Hybrid Adders for High Speed Arithmetic Circuit, International Journal of VLSI design & Communication Systems (VLSICS), 2012,3(3).
- [15] Rajput, Sethi.M, Dobriyal.P, Sharma.K, Sharma.G,A Novel, High Performance and Power Efficient Implementation of 8x8 Multiplier Unit using CMOS Technique, IEEE,2013.

# Proficient Mining of Informative Gene from Microarray Gene Expression Dataset Using Machine Intelligence

Priya Ravindran<sup>a,1</sup>, S. Jayanthi<sup>a</sup>, Arun Kumar Sivaraman<sup>b</sup>, Dhanalakshmi R<sup>c</sup>,  
A.Muralidhar<sup>b</sup>, Rajiv Vincent<sup>b</sup>

<sup>a</sup> Dept of CSE, Agni College of Technology, Chennai, India

<sup>b</sup> School of Computer Science and Engineering, VIT University, Chennai, India

<sup>c</sup> Department of CSE, KCG College of Technology, Chennai, India

**Abstract.** The quick improvement of DNA microarray innovation empowers analysts to quantify the expression levels of thousands of genomic data and permits scientists effortlessly pick up and understanding the mind-boggling prediction in tumors based on genomic expression levels. The application in malignancy has been demonstrated and extraordinary achievement has been performed in both conclusion and clarification using the neurotic methodologies. In many cases, DNA microarray information about gene contains a large number of qualities and the majority of them are turned out to be uninformative and excess. In the interim, little size of tests of microarray information undermines the determination precision of factual models. In this way, choosing profoundly discriminative qualities from crude quality genetic expression can enhance the execution of genetic prediction and chopped down the cost of medicinal analysis. Pearson Correlation based Feature Selection strategy with machine learning methodologies is effective to locate a conspicuous arrangement of components which can be utilized to anticipate and idealize the blend of quality to analyze the disease. As conflicting to the customary cross approval, filter one cross approval technique is connected for the analyses. As needs be, the proposed blend between the PCBFS and Machine Learning methodology is an effective apparatus for disease grouping and can be actualized as a genuine clinical supportive system.

**Keywords.** microarray gene dataset, machine intelligence, human cancer classification, feature engineering.

## 1. Introduction

Precise disease determination is essential for the effective utilization of particular treatments. In spite of the fact that tumor order has enhanced throughout the most recent decade, there is as yet a requirement for a completely robotized and less subjective technique for malignancy conclusion. Late reviews showed that DNA microarrays could give valuable data to malignancy characterization at the quality expression level because of their capacity to gauge the plenitude of delivery person ribonucleic corrosive transcripts for a huge number of qualities at the same time.

A small number of machine-learning computations have as of now been associated for tumors classification by utilizing microarray information. By utilizing the Voting

<sup>1</sup>Priya Ravindran, Dept. of Computer Science and Engineering, Agni College of Technology, Chennai, India  
E-mail: priyaravindran.analyst@gmail.com

maps to break down intense lung (Golub et al., 1999). Bolster trajectory machines are connected to multiclass growth determination by (Ramaswamy et al., 2001). Various leveled bunching is utilized to examine colon cancer (Alon et al., 1999). The superlative characterization outcomes are accounted for by (Li et al., 2003) and (Antonov et al., 2004). (Li et al., 2006) utilized a lead revelation strategy along with greatest edge straight system. In this research, we deliberate two traditional ways to deal with highlight subclass choice, by particularly considering, wrapper and channel tactics, for quality determination. Wrappers and channels contrast by the way they assess include subsets. Channel approaches evacuate immaterial components as per general qualities of raw information. Wrapper methods, by complexity, smear machine mastering calculations to highlight datasets and utilize cross-approval to assess the score of highlight subsets. Most techniques for quality determination for microarray information investigation concentrate on channel approaches, in spite of the fact that there are a couple of distributions on smearing wrapper methods (Inza et al., 2004). This research paper is technically organized as follows. We start with a short prologue to highlight subclass choice, trailed by a portrayal of highlight wrappers, channels and FSC, which is basically a channel calculation. We talk about the points of interest and impediments of utilizing wrappers and channels to choose featured subclasses. From there on, we display the test comes about on intense lung and lymphoma dataset information. The preceding segment talks about the outcomes and finalize this research paper.

## 2. Existing Methods

Given a microarray growth informational collection  $D$ , which comprises  $n$  tests from various malignancy sorts or subclasses, we need to assemble a scientific display which will delineate examples to their subclasses. Each specimen has  $m$  qualities as its elements. The supposition here is that not all qualities restrained by a microarray dataset are identified with tumor arrangement. A few qualities are superfluous and excess from the machine learning perspective. It is notable that the incorporation of unimportant and repetitive in-arrangement may hurt execution of some machine learning calculations.

### 2.1 Distance Measures

The partition estimations compute the imminence of the things in perspective on different characteristics. These estimations are disengaged into two social occasions as comparability or uniqueness estimations. Likeness estimations measure how relative any match of individuals is and all around take esteems in the region of 0 and 1. The regard 0 means "no likeness" while 1 suggests an "all out closeness" (Tan, 2006). On the other hand, distinction estimations measure how far the articles are. Subsequently, the disparity estimations can be taken as the detachment between sets. Articles with divergence score close to 0 are believed to be nearby. The similarity among the things gets worse as the divergence score lengthens. The multiple sorts of divisions make the divergences among the things increases gradually as the partition among the items increases. Minimum highlight is agreed to the greater partitions. The three estimations obtained from the mentioned situations, describes the divergences among the objects in the sense of their incomparable complexities. In course of action, along these lines,



these estimations will evaluate the degree differentiates among the recognitions at core interests.

An additional measurement is notorious as the cosine-edge evacuate. It basically evaluates the cosine regard between the different vectors. The position among two vectors became increasing and the measurement will be progressively similar to 1, exhibits that two vectors became similar to one another. Along these lines, it varies well by appointing a similarity metric.

$$\text{Cosine - Angle Distance: } d(x, y) = 1 - \frac{\sum_{i=1}^n x_i y_i}{\sqrt{\sum_{i=1}^n x_i^2} \sqrt{\sum_{i=1}^n y_i^2}}$$

Another measurement was projected by (Möller-Levet et al., 2005) and termed as Petite Time sequence Space. It was described to check the contour mismatches amid the short-range course of action. This measurement, on a very basic level, measures the partition between the inclinations of the time-course of action at each time break, and usages their sums over different time centers. Petite Time sequence Space partition can be estimated as pursues:

$$\text{Petite Time sequence Space: } d(x, y) = \sum_{i=1}^{n-1} \left( \frac{x_{i+1} - x_i}{t_{i+1} - t_i} - \frac{y_{i+1} - y_i}{t_{i+1} - t_i} \right)$$

Where x and y are the time intervals with n time centers; and  $t_i$  exhibits the consequent time of the  $i^{\text{th}}$  recognition. Rather than the underlying three estimations portrayed in this section, the estimations gained from above condition get the dissimilarities between the things in perspective on their shapes. All things considered, every partition metric describes the uniqueness between the things by using one of the characteristics which are, all around, the size and grade contrasts.

### 3. Tailored Analytic Hierarchy Process

Using pairwise comparisons, the relative importance of one gene over other can be expressed. Here we show how to get a ranking of properties from a pairwise matrix. Mathematically saying, Eigen Vector is the best approach. To achieve this ranking, a quick computational way is to lift the pairwise matrix to powers that are squared each time successively. Then the sums of the rows are measured and normalized. If the difference between these quantities is smaller than the specified value in two consecutive measurements, the machine is instructed to stop. The gene similarity scores are represented in the matrix below: Using pairwise comparisons, the relative importance of one gene over other can be expressed. Here we show how to get a ranking of properties from a pairwise matrix. Mathematically saying, Eigen Vector is

the best approach. To achieve this ranking, a quick computational way is to lift the pairwise matrix to powers that are squared each time successively. Then the sums of the rows are measured and normalized. If the difference between these quantities is smaller than the specified value in two consecutive measurements, the machine is instructed to stop.

Eigen Value can be calculated by,

$$\left( \begin{array}{l} \lambda_1 = ( [SM_{(1,1)}, SM_{(1,2)} \dots\dots\dots, SM_{(1,n)}] \cdot [\epsilon_1, \epsilon_2, \dots\dots, \epsilon_n]^T ) / \epsilon_1 \\ \lambda_2 = ( [SM_{(2,1)}, SM_{(2,2)} \dots\dots\dots, SM_{(2,n)}] \cdot [\epsilon_1, \epsilon_2, \dots\dots, \epsilon_n]^T ) / \epsilon_2 \\ \lambda_3 = ( [SM_{(3,1)}, SM_{(3,2)} \dots\dots\dots, SM_{(3,n)}] \cdot [\epsilon_1, \epsilon_2, \dots\dots, \epsilon_n]^T ) / \epsilon_3 \\ \lambda_n = ( [SM_{(n,1)}, SM_{(n,2)} \dots\dots\dots, SM_{(n,n)}] \cdot [\epsilon_1, \epsilon_2, \dots\dots, \epsilon_n]^T ) / \epsilon_n \end{array} \right)$$

#### 4. Results and Discussion

We used microarray analysis as a case study, where genes with identical expressions or similar molecular functions were grouped together, to assess the efficacy of the proposed formulation. In particular, on three benchmark microarray gene expression datasets, the proposed feature selection method is tested and evidence is given that the proposed method provides more precise results than the state-of-the-art methods of gene selection. The results are discussed based on three different cancer datasets taken in various time intervals. Overlap matrices are used to evaluate the performance of different data mining approaches.

##### 4.1 Overlap Matrix in Gene Selection Approaches: For TCL microarray

The overlap between the first 30 nominated human genes in the six gene assortment approaches for the TCL dataset is shown in table 1. There are 28 common genes between Tailored-AHP and Wilcoxon out of 30 selected genes, and also 27 common genes between Tailored-AHP and ROC out of 30 selected genes.

**Table 1.** overlap matrix between gene assortment techniques: for TCL dataset

	T-test	Entropy	ROC	Wilcoxon	SNR	TAHP
T-test	30	18	26	28	14	26
Entropy	18	30	17	18	9	15
ROC	26	17	30	28	18	27
Wilcoxon	28	18	28	30	16	28
SNR	14	9	18	16	30	19
TAHP	26	15	27	28	19	30

#### 4.2 LOOCV Accuracy On TCL Dataset

The normalized LOOCV accurateness among multiple gene datasets of the four clustering techniques, i.e. K-Means, Hierarchical, Apriori, and DSSOM is evaluated in table 2 for the TCL dataset.

**Table 2.** LOOCV precision on TCL dataset

		Entropy	ROC	Wilcoxon	SNR	TAHP
K-Means	93.67	96.30	93.82	97.60	95.23	96.43
Apriori	94.63	92.46	93.74	93.19	92.18	94.68
Hierarchical	97.49	93.38	96.84	97.34	97.57	95.74
DSSOM	98.32	97.56	94.38	96.37	98.23	99.21

### 5. Summary and Conclusion

In order to evaluate and interpret highly significant data (such as microarray datasets), several approaches have been explored that combine feature selection and classification, most of which are considered to be obsolete and insignificant. Until running either classification techniques on the selected features, or running a further 'combined' feature selection/classification process, it has generally been found that previous feature selection is advantageous. We proposed a new mechanism to take into account the ranking results of individual gene selection methods including t-test, entropy, receiver operating characteristic curve and signal to noise ratio for informative gene selection by using Statistical Analysis with Pearson Correlation System and performing modifications in the traditional Analytic Hierarchy Process (named as Tailored-AHP). For the reason that the grading would be diverse for each technique, the grading result of a solitary technique is forever uncertain. In conjunction with the Pearson Correlation Tool, the Tailored-AHP shows heftiness and ascendancy assessed for different gene ranking approaches. Gene ranking approaches results are evaluated by leaving one out cross validation (LOOCV). The use of Tailored-AHP on average produces approximately 99 percent LOOCV accuracy in the TCL dataset, which is the greatest statistic compared to those of the remaining approaches. Similarly, in the lung dataset, the highest LOOCV precision, more than 98 percent, is also the product of the Tailored-AHP with Pearson Correlation method. The Tailored-AHP also contributes to the greatest LOOCV precision at more than 96 percent in the breast dataset.

### References

- [1] Agathangelou, A., Bieche, I., Ahmed-Choudhury, J., Nicke, B., Dammann, R., Baksh, S., Gao, B., Minna, J., Downward, J., Maher, E., Latif, F. Identification of novel gene expression targets for the ras association domain family 1 (rassfla) tumor suppressor gene in nonsmall cell lung cancer and neuroblastoma. *Cancer Res*, 2003, 63 (17), 5344–5351.
- [2] Alizadeh, A.A., M.B. Eisen, R.D., Ma, C., Lossos, I., Rosenwald, A., Boldrick, J., Sabet, H., Tran, T., Yu, X., Powell, J., Yang, L., Marti, G., Moore, T., Hudson, J.J., Lu, L., Lewis, D., Tibshirani, R., Sherlock G., Chan, W., Greiner, T., Weisenburger, D., Armitage, J., Warnke, R., Levy, R., Wilson, W., Grever, M., Byrd, J., Botstein, D., Brown, P., Staudt, L.M. Distinct types of diffuse large b-cell lymphoma identified by gene expression profiling. *Nature*, 2000, 403 (6769), 503–511.

- [3] Alon, U., Barkai, N., Notterman, D., Gish, K., Ybarra, S., Mack, D., Levine, A. Broad patterns of gene expression revealed by clustering analysis of tumor and normal colon tissues probed by oligonucleotide arrays. *Proc. Natl. Acad. Sci.*, 1999, 96 (12), 6745–6750.
- [4] Antoniadis, A., Lambert-Lacroix, S., Leblanc, F. Effective dimension reduction methods for tumor classification using gene expression data. *Bioinformatics*, 2003, 19, 563–570.
- [5] Antonov, A.V., Tetko, I.V., Mader, M.T., Budczies, J., Mewes, H.W. Optimization models for cancer classification: extracting gene interaction information from microarray expression data. *Bioinformatics*, 2004, 20, 644–652.
- [6] Crawford, A., Beckerle, M. Purification and characterization of zyxin, an 82,000-dalton component of adherens junctions. *J. Biol. Chem.*, 1991, 266 (9), 5847–5853.
- [7] Fayyad, U., Irani, K. Multi-interval discretization of continuousvalued attributes for classification learning. *Proceedings of IJCAI-93, 13th International Joint Conference on Artificial Intelligence*, 1993, pp. 1022–1027.
- [8] Frank, E., Hall, M., Trigg, L., Holmes, G., Witten, I.H. Data mining in bioinformatics using Weka. *Bioinformatics*, 2004 20, 2479–2481.
- [9] Ramakrishnan M et.al., Footprint Based Recognition System. in the month of April for the International Journal Communication in Computer and Information System (CCIS) Journal (Springer) Volume 147, Part 3, 358-367, DOI: 10.1007/978-3-642-20573-6\_63, April 2011
- [10] M. Indhumathi et al , “Healthcare Management of Major Cardiovascular Disease-A review”, 2021 6th International Conference on Inventive Computation Technologies (ICICT), (DOI: 10.1109/ICICT50816.2021.9358519 )
- [11] Ambeth Kumar.V.D, Dr.S.Malathi, V.D.Ashok Kumar (2015) .Performance Improvement Using an Automation System for Segmentation of Multiple Parametric Features Based on Human Footprint. for the Journal of Electrical Engineering & Technology (JEET) , vol. 10, no. 4, pp.1815-1821 , 2015. [<http://dx.doi.org/10.5370/JEET.2015.10.4.1815>]
- [12] Ambeth Kumar.V.D et,al, .Enhancement in Footprint Image using Diverse Filtering Technique. *Procedia Engineering journal*, Volume 8, No.12, 1072-1080, 2012. [[doi:10.1016/j.proeng.2012.01.965](https://doi.org/10.1016/j.proeng.2012.01.965)]

# Balanced and Energy Efficient Multi Core-Aware Virtual Machine Placement Algorithm Using Multi-Dimensional Resource Space Partition Model

Nagadevi <sup>a,1</sup> and Kasmir Raja<sup>b</sup>

<sup>a</sup> Assistant Professor, Dept of ECE, SRM Institute of Science and Technology, Chennai, India

<sup>b</sup> UG Scholar, Dept of ECE, SRM Institute of Science and Technology, Chennai, India

**Abstract:** Optimal resource management is required in a data center to allocate the resources to users in a balanced manner. Balanced resource allocation is one of the key challenges in the data center. The multi-dimensional resources of a data center must be allocated in a balanced manner in all the dimensions of physical machines. The unbalanced resource allocation leads to unused residual resource fragments. The unused residual resource fragments leads to resource wastage. If the multi-dimensional data center resources are allocated in a balanced manner, the resource wastage does not occur. Also, the balanced allocation improves the power consumption. The balanced resource allocation reduces the resource wastage as well as reduces the power consumption. In this paper, we have designed a Balanced Energy Efficient Multi-Core Aware Virtual Machine Placement algorithm (MCA-BEE-VMP) using multi-dimensional resource space partition model to balance the resources like CPU and memory and also to reduce the power consumption. We used Google Cloud Jobs (GoCJ) dataset for the simulation. In our simulation of MCA-BEE-VMP using Cloud Sim simulation tool we have achieved balanced CPU and memory resources allocation in two dimensions of a physical machine. The resource wastage and power consumption is improved and the simulation results were analyzed.

**Keywords:** Multi-core, Virtual Machine Placement, Data Center, Multi-dimensional, Space partition model, balanced, energy efficient, Google Cloud Jobs, Cloud Sim

## 1. Introduction

Nowadays, the end users of a cloud computing run their applications and store their data in the data center(DC). The Cloud Service Providers provision the resources (CPU, Memory, Network etc.) requested by the users in the form of a virtual machines (VM). e.g. Amazon EC2 instances.

---

<sup>1</sup>Nagadevi, Assistant Professor, Dept of ECE, SRM Institute of Science and Technology, Chennai, India.  
Email:nagadevs@srmist.edu.in<sup>1</sup>

The user requested virtual machines are created in suitable physical machines (PM) of a data center. The process of creating a VM on a suitable PM is popularly known as Virtual Machine Placement (VMP). The optimal placement of VM on PM leads to save resources, improve power consumption and resource utilization. Considering the PMs of a data center as a multi-dimensional resources in the dimensions like, CPU, Memory, Storage, the process of VMP must place VMs in such a way that, any VMP must balance the PMs in all the dimensions of it.

## 2. Background

The main objectives of the VMP problem is to reduce power consumption by reducing number of running physical machines, to do dynamic resource allocation, to improve resource utilization, to minimize a cost of a data center, to improve SLA, to reduce number of VM migrations, to reduce resource wastage. The VMP could be categorized as, Single Dimensional VM Placement-Only the computational demand and computational capacity is considered for VMP. VM is placed if CPU requirement is less than the total available CPU capacity of a PM Multi-Dimensional VM Placement-Not only computational capacity, also, the memory, storage, bandwidth, network etc., are considered. VM is placed if resource requirements satisfies the resources in all dimensions.

## 3. Related Work

Earlier, many algorithms have been proposed by authors[1]–[5] for VMP, but the physical cores (pCPU) of a PM is not considered except[6], [7]. In most of the existing VMP algorithms authors have considered the total CPU capacity of a PM not the pCPU capacity of a PM for VMP. Resource usage and power calculation is calculated for virtual machine placement.[8]. Energy efficiency is discussed in [5], [9],[3], [10] [13-15].

## 4. Proposed System Model

We have deigned our algorithm based on, placing ‘n’ number of virtual machines on ‘m’ number of physical machines. Consider, there are, m number of physical machines, such as PM-list= {pm<sub>1</sub>, pm<sub>2</sub>... pm<sub>m</sub>} and n, number of virtual machines such as VM-list= {vm<sub>1</sub>, vm<sub>2</sub>...vm<sub>n</sub>}.

So, the overall CPU Utilization of m, number of PMs is calculated as,

$$CPU\ Utilization = \frac{Total\ Number\ of\ MIPS\ used\ by\ all\ Active\ Cores\ of\ a\ PM}{Total\ CPU\ (MIPS)\ capacity\ of\ a\ PM} \quad (1)$$

Similarly, the overall Memory Utilization of m, number of PMs is calculated as,

$$Memory\ Utilization = \frac{Total\ amount\ of\ RAM\ used\ by\ all\ Active\ Cores\ of\ a\ PM}{Total\ RAM\ capacity\ of\ the\ PM} \quad (2)$$

The overall Power Consumption of a cloud data center is,

$$\sum_{j=1}^m Power = \sum_{j=1}^m P^j \cdot \left[ (pow_j^{busy} - pow_j^{idle}) \frac{\sum_{i=1}^n vm_i^{mips} .x_{ij}}{pm_j^{ncores} pm_j^{c-mips}} + pow_j^{idle} \right] \tag{3}$$

where  $\sum_{j=1}^m Power$  is the power consumption of  $m$ , number of PMs in proposed system.  $pow_j^{busy}, pow_j^{idle}$  are the power consumption of  $pm_j$  at busy and idle time.  $P^j$ , specifies that the physical machine  $pm_j$  is active. The potential cost of resource wastage of a PM in a data center, in multiple dimensions like CPU, memory, disk and so on, is calculated as ,

$$W_j = \frac{|L_j^p - L_j^m| + \epsilon}{U_j^p + U_j^m} \tag{4}$$

where  $U_j^p$  and  $U_j^m$  are the normalized CPU and memory resource usage.  $L_j^p$  and  $L_j^m$  are the normalized remaining CPU and memory resource.  $\epsilon$ , is the very small positive real number and its value is set to 0.0001.

The requirement is to find a map

Map F: VM-list  $\rightarrow$  PM-list

between PM-list and VM-list such that to satisfy all the below mentioned objective functions.

The objective function our proposed algorithm is,

$$\min \sum_{j=1}^m RW \tag{5} \qquad \min \sum_{j=1}^m Power \tag{6}$$

where RW, is the resource wastage of  $m$  number of physical machines and Power, is the power consumption of  $m$ , number of physical machines

### 5. Balanced Energy Efficient Multi-Core-Aware VMP algorithm using Multi-Dimensional resource space partition Model (MCA-BEE-VMP)

We have proposed MCA-BEE-VMP, algorithm using the multi-dimensional resource space partition model [8], [11], [12] to balance the resources in  $d=2$ , dimensions of a PM .

#### 5.1 Multi-Dimensional Space Partition Model

PM is the multi-dimensional resource .To represent the PM as a multi-dimensional resource, a vector space partition model shown in Fig.1 is used for our proposed MCA-BEE-VMP. Each PM is represented as a point,  $P (RU_j^{cpu}, RU_j^{mem})$ , in a two dimensional X, Y axis, by taking CPU capacity on X-axis and memory capacity on Y-axis. A new point NP ( $RUR_j^{cpu}, RUR_j^{mem}$ ) in the resource space is determined for PM, in which the PM will settle after placing a new VM. Fig.1 shows the multi-dimensional space partition model in which different domains of resource space is formulated. The domains in the model are Acceptance Domain (AD), Balanced Domain (BD) and

Unbalanced Domain (UD). The domain to which the PM belongs is determined by the position of the corresponding point P and NP.AD has the highest priority for being selected for VMP .In AD the resources nearly exhausted and PMs have small resource wastage in it.BD has a second highest priority for VMP and is a balanced space to place a VM.UD indicates the worst case resource wastage for a PM and it is avoided in our algorithm for VMP. The Resource Utilization (RU) of a PM in dimensions CPU and memory is calculated as a current state vector point, P ( $RU_j^{cpu}$ ,  $RU_j^{mem}$ ) as,

$$C_j^{cpu} = pm_j^{c-mips} . pm_j^{ncores} \quad RU_j^{cpu} = \frac{x_{ij} . \sum_{i=1}^n vm_i^{mips}}{C_j^{cpu}} \quad RU_j^{mem} = \frac{x_{ij} . \sum_{i=1}^n vm_i^{mem}}{pm_j^{mem}}$$

where  $C_j^{cpu}$  is the total CPU capacity of a pm<sub>j</sub>,  $RU_j^{cpu}$  is the CPU resource utilization of pm<sub>j</sub> and  $RU_j^{mem}$  is the memory resource utilization of pm<sub>j</sub>. Resource Usability Ratio (RUR) determines whether the PM is good enough to hold a new VM according to the space partition model. So, residual resource fragments of PM are reduced. A residual resource fragment which increases the resource wastage in a PM is minimized. Thus the RUR is a metric to determine the probable placement status of a PM.RUR is calculated for all PMs after placing a new VM, in resource dimensions CPU and memory as new state vector point, NP( $RUR_j^{cpu}$ ,  $RUR_j^{mem}$ ) as,

$$RUR_j^{cpu} = \frac{C_j^{cpu} . RU_j^{cpu} + VM_{new}^{mips}}{C_j^{cpu}} \quad RUR_j^{mem} = \frac{pm_j^{mem} . RU_j^{cpu} + VM_{new}^{mem}}{pm_j^{mem}}$$

where  $RUR_j^{cpu}$  is the CPU resource usability ratio of pm<sub>j</sub>,  $RUR_j^{mem}$  is the memory resource usability ratio of pm<sub>j</sub>,  $VM_{new}^{mips}$  is the MIPS requirement of a new VM and  $VM_{new}^{mem}$  is the memory demand of new VM.Given the point P ( $RU_j^{cpu}$ ,  $RU_j^{mem}$ ) and the parameters r0 and R0, the domain in which the PM lies is determined as a function  $f(P)$  and is given as,

$$f(P) = \begin{cases} AD, & \text{if } distance(P,E) \leq r0; \\ BD, & \text{if } RU_j^{cpu} \text{ and } RU_j^{mem} \leq (1 - R0) \\ UD, & \text{otherwise} \end{cases}$$

where,  $distance(P,E)$  is the distance between the two points P and E(1,1), r0 is the satisfaction factor usually set to 0.0, just to ensure the idea of balancing in multi-dimensional resources and R0 is the balance factor .The PM selection is very much affected by R0.

### 5.2 MCA-BEE-VMP Algorithm

MCA-BEE-VMP algorithm is shown in Algorithm 1.Initially, the PMs with the available pCPU capacity and memory is selected for placing a VM. For each PM results from step 1, the PM is selected for step 3, if anyone of the pCPU is sufficient enough to hold the new VM along with the current CPU load. For the PMs results from step 2, the point P and NP is determined .If P is in AD or NP is in BD, then the first PM is selected as a target PM and first pCPU of that PM that has enough resource to place VM, is selected as a target pCPU



**Algorithm 1: Multi Core-Aware Balanced Energy Efficient Virtual Machine Placement Algorithm (MCA-BEE-VMP):**

```

Input:      VM-List, PM-List;
Output:     Placement of VMs on PM-Cores
for each  $pm_j \in PM\text{-List}$ 
for each core,  $k = (1,2,\dots, pm_j^{ncores})$ 
     $cpload(pm_j^k) = 0;$ 
end for
end for
for each  $vm_i \in VM\text{-List}$ 
for each  $pm_j \in PM\text{-List}$ 
if (  $vm_i^{mips} \leq pm_j^{c-mips}$  &&  $vm_i^{mem} \leq pm_j^{mem}$  ) then
Find the point,  $P(RU_j^{cpu}, RU_j^{mem})$  ;
Find the point,  $NP(RUR_j^{cpu}, RUR_j^{mem})$ ;
if (  $P \in AD \parallel NP \in BD$  ) then
for each pCPU,  $k = (1,\dots, pm_j^{cores})$ 
if ( $vm_i^{mips} + cpload(pm_j^k) \leq pm_j^{c-mips}$ ) then
Place  $vm_i$  on  $pm_j^k$ ;
 $cpload(pm_j^k) = cpload(pm_j^k) + vm_i^{mips}$ ;
 $pm_j^{ram} = pm_j^{ram} - vm_i^{mem}$ ;
 $p^j = 1; c^k = 1;$ 
break;
endif
endif
endif
else
if (  $j == PM\text{-List.size}()$  ) then
return unable to place  $vm_i$  on PM-List
else
continue;
endif
endif
endif
return placement of VM-List in PM-List
    
```

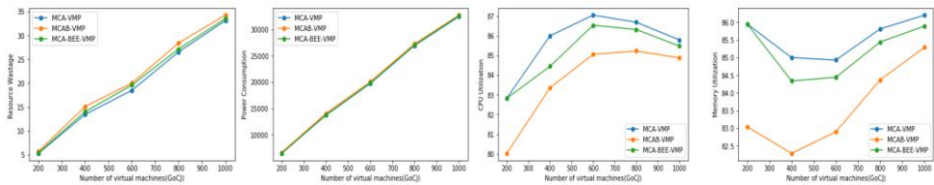
**Algorithm 2: Multi Core-Aware Virtual Machine Placement Algorithm (MCA-VMP):**  
 We have compared our algorithm with MCA-VMP, where the virtual machines are placed on a PM based on First Fit strategy.

**Algorithm 3: Multi Core-Aware Balanced Virtual Machine Placement Algorithm (MCAB-VMP):**

We also have compared our proposed algorithm with MCAB-VMP, in which the distance between the VM and PM is calculated using Dot Product.

**6. Performance Evaluation**

The simulation results using MCA-BEE-VMP is shown in Figure .1.



(a)Resource Wastage(b)Power Consumption in watts(c) CPU Utilization(d)Memory Utilization

**Figure 1.** Simulation results using MCA-BEE-VMP algorithm (a)Resource Wastage (b)Power Consumption in watts(c) CPU Utilization (d)Memory Utilization

## 7. Conclusion

In this research, we have argued that core awareness is necessary in the process of VMP in cloud data centers. The non-core aware VM placement algorithms leads to sub-optimal results and PM overload. We designed a new algorithm based on cores called MCA-BEE-VMP algorithm using multi-dimensional resource partition model. Our simulation results shows that MCA-BEE-VMP is efficient in terms of resource wastage and power consumption. Also, the CPU and memory utilization of all the physical machines is balanced.

## References

- [1] Beloglazov.A and Buyya.R .Managing Overloaded Hosts for Dynamic Consolidation of Virtual Machines in Cloud Data Centers under Quality of Service Constraints. *IEEE Trans. Parallel Distrib. Syst.*, vol. 24, no. 7, pp. 1366–1379, Jul. 2013, doi: 10.1109/TPDS.2012.240.
- [2] Beloglazov.A and Buyya.R. Energy Efficient Allocation of Virtual Machines in Cloud Data Centers, in 2010 10th IEEE/ACM International Conference on Cluster, Cloud and Grid Computing, Melbourne, Australia, 2010, pp. 577–578, doi: 10.1109/CCGRID.2010.45.
- [3] Abohamama.A.S and Hamouda.E.A hybrid energy–Aware virtual machine placement algorithm for cloud environments, *Expert Systems with Applications*, vol. 150, p. 113306, Jul. 2020, doi: 10.1016/j.eswa.2020.113306.
- [4] Alouane.M and H. El Bakkali.Virtualization in Cloud Computing: Existing solutions and new approach, in 2016 2nd International Conference on Cloud Computing Technologies and Applications (CloudTech), Marrakech, Morocco, May 2016, pp. 116–123, doi: 10.1109/CloudTech.2016.7847687.
- [5] Azizi.S, Shojafar.M,Abawajy.J, and R. Buyya, GRVMP: A Greedy Randomized Algorithm for Virtual Machine Placement in Cloud Data Centers, *IEEE Systems Journal*, pp. 1–12, 2020, doi: 10.1109/JSYST.2020.3002721.
- [6] Z. Á. Mann, Allocation of Virtual Machines in Cloud Data Centers—A Survey of Problem Models and Optimization Algorithms, *ACM Comput. Surv.*, vol. 48, no. 1, pp. 1–34, Sep. 2015, doi: 10.1145/2797211.
- [7] Mann.Z.A .Multicore-Aware Virtual Machine Placement in Cloud Data Centers. *IEEE Trans. Comput.*, vol. 65, no. 11, pp. 3357–3369, Nov. 2016, doi: 10.1109/TC.2016.2529629.
- [8] Gupta.M.K, A. Jain, and T. Amgoth, Power and resource-aware virtual machine placement for IaaS cloud, *Sustainable Computing: Informatics and Systems*, vol. 19, pp. 52–60, Sep. 2018, doi: 10.1016/j.suscom.2018.07.001.
- [9] Beloglazov.A, Abawajy.J, and Buyya.R. Energy-aware resource allocation heuristics for efficient management of data centers for Cloud computing. *Future Generation Computer Systems*, vol. 28, no. 5, pp. 755–768, May 2012, doi: 10.1016/j.future.2011.04.017.
- [10] Aruna.P and Vasantha.S . A Meta-Heuristic based Virtual Machine Placement and Migration for Optimal Resource Utilization in the Cloud Computing Environment, *Asia. Jour. Rese. Soci. Scie. and Human.*, vol. 6, no. 5, p. 725, 2016, doi: 10.5958/2249-7315.2016.00148.9.
- [11] X. Li, Z. Qian, S. Lu, and J. Wu, Energy efficient virtual machine placement algorithm with balanced and improved resource utilization in a data center, *Mathematical and Computer Modelling*, vol. 58, no. 5–6, pp. 1222–1235, Sep. 2013, doi: 10.1016/j.mcm.2013.02.003.
- [12] W. Huang, X. Li, and Z. Qian, An Energy Efficient Virtual Machine Placement Algorithm with Balanced Resource Utilization, in 2013 Seventh International Conference on Innovative Mobile and Internet Services in Ubiquitous Computing, Taichung, Taiwan, Jul. 2013, pp. 313–319, doi: 10.1109/IMIS.2013.59.
- [13] Ambeth Kumar.V.D (2017).Efficient Routing for Low Rate Wireless Network a Novel Approach. *International Journal of Image Mining*, Vol. 2, Nos. 3/4, 2017, 2017
- [14] Nanagasabapathy .Ket.al. Validation system using smartphone luminescence. *IEEE International Conference on Intelligent Computing, Instrumentation and Control Technologies (ICICICT)*, Pages: 235 – 239, 6-7 July 2017, Kannur, India
- [15] Ambeth Kumar.V.D, Ashok Kumar.V.D, Divakar.H ,Gokul.R. Cloud enabled media streaming using Amazon Web Services.*IEEE (ICSTM)*, Pages: 195 – 198, 2-4 Aug. 2017, India (DOI: 10.1109/icstm.2017.8089150)

# LoRaWAN Based Manhole Cover Monitoring System

Aman Kumar Tiwari,<sup>a,1</sup> Priyanka Chaudhari<sup>b</sup>, Shardul Pattewar<sup>b</sup>, and Rohini Deshmukh<sup>b</sup>

<sup>a,1</sup> *UG Scholar, Dept of CSE, Sinhgad Academy of Engineering, Pune, India*

<sup>b</sup> *Professor, Dept of CSE, Sinhgad Academy of Engineering, Pune, India*

**Abstract.** An on-line monitoring system using LoRa based wireless technology for manhole cover is proposed. The system includes sensor sensing nodes, LoRaWAN network and application. LoRaWAN based IoT has very low power consumption for long-distance transmission. We use the accelerometer sensor to monitor the position, displacement or damage of manhole covers used in sewage systems. If these covers are moved or damaged, then LoRa board alerts the authorities LoRa gateway. The gateway is connected to The Things Network (TTN), a cloud-based crowd-funded open source LoRaWAN platform. The data is uploaded to the cloud and stored, and it will alert to the maintenance department. On TTN, our application will be launched and integrated with different features such as SMS.

**Keywords.** LoRa, LoRaWAN, Gateways, The Things Network, Manhole Cover, Smart City.

## 1. Introduction

Internet of Things and M2M communication has extremely grown in the deployment of sensor node. The development in IoT is in all stages of industry and market areas. It defines the ways of designing, managing and maintaining the networks, data, cloud and connections. IoT-enabled devices, sensors, advanced data analytics can be used for applications such as smart parking, security, agricultural farming, e-health and wearables and many more [1, 3]. So many developments in blockchain technologies, machine learning, data analytics and artificial intelligence, there is growth in the deployments and its applications in all the sectors of industry, profession and society. Smart cities are developed so much that it made urban lives more attractive such as fast, convenient transportation systems, safe street lighting and energy-efficient buildings. IoT applications uses low complexity and energy efficient nodes for various uses on wide area networks. To support such requirements, a model of IoT, called LoRa networks was introduced. LPWAN is a wireless IoT technology which covers larger

---

<sup>1</sup> Priyanka Chaudhari, Department of Computer Engineering, Sinhgad Academy of Engineering, India; E-mail: c.piyu@outlook.com

areas, low data rate and long battery life [3]. Low power consumption and long-distance transmission characteristics have good development anticipation in the field of IoT. In our paper, we proposed to design and develop LoRaWAN based system to monitor manhole covers used in sewage systems. In developing countries, monitoring the health of manhole cover is a challenging problem [4]. Often, manhole covers are damaged, as shown in Fig. 1 or stolen because of that several accidents and deaths. Our system will sense where about of manhole cover and its health. In case of damage or theft, it will intimate the cloud-based server in real-time, and the server will alert the concerned officers or personnel about the same so that they can take the necessary action as soon as possible.



Figure 1. A damaged manhole cover

## 2. LoRa WAN Technology and The Things Network

LoRa is low power network technology. This is one of the long range and latest technologies contingent on chirp spread spectrum technology [5, 6]. LoRa is the protocol that was developed to define the upper layers of the network. LoRa is a cloud-based MAC layer protocol, manages the communication between LPWANgateways and end node devices. The LoRa Alliance sustains LoRaWAN. The block diagram of the typical LoRaWAN network is as shown in Fig. 2.

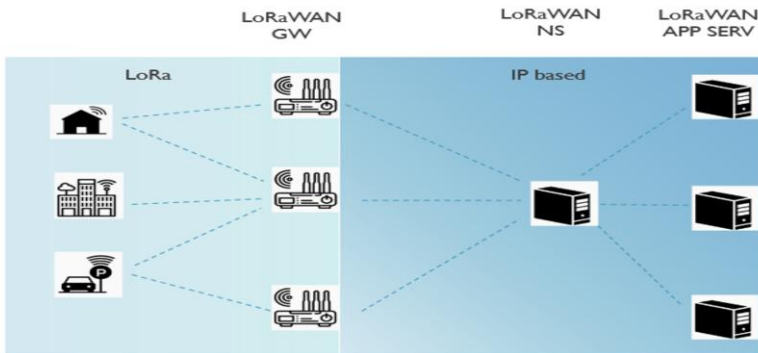


Figure 2. Block diagram of LoRaWAN network

The Things Network is cloud-based decentralized and open-source LoRaWAN platform to exchange data with applications [7]. It connects low power end devices to gateways which may be placed far away. A TTN application retrieves many parameters such as:

- the registered devices such as sensor nodes, their health and the data they are sending in real-time
- It allows identifying nodes through application ID on the network
- general settings of the application such as network keys, security, activation type
- a payload decoder which gives instructions used for converting the incoming messages

Once application is functional, one can inscribe a device to use it. This gives the necessary IDs and security keys to connect a sensor node to the network. Once the sensor node has joined the network, we can retrieve the data it sends in real-time, either directly through other data collection services or TTN interface.

### 3. Related work

Researches and projects have been undertaken on LoRaWAN for different applications used in smart cities and other places. Green Cityzen and the United Nations secure water delivery in African refugee camps using the LoRaWAN project aims to secure 15 camps hosting nearly 2 million refugees in Uganda and Ethiopia. The GreenCityzen Business application manages the fleet of sensors, monitors the key indicators, generates alerts, and helps make the best decisions and control invoicing of their water tank suppliers. The TTN deploys a LoRaWAN network, while the French start-up has installed a network of 300 Ultrasonic Level sensors with an IoT platform that continuously monitors available water stocks and truck deliveries [5]. Smart electric meter using LoRa aims to take electric energy consumption readings reading periodically and send it to the Internet for monitoring and control [7]. A smart prepaid electric meter with LoRa module measures the data such as energy power, voltage etc. and sends it to a gateway. Gateway is the central unit which collects all the data from all the meters, and it is connected with the local storage device. The gateway sends the data to the cloud [9].

### 4. Implementation

In this paper, we propose to design and develop LoRaWAN based system to monitor manhole covers used in sewage systems. In developing countries, monitoring the health of manhole cover is a challenging problem. Many times, manhole covers are damaged or stolen because of that several accidents and deaths. Our system will sense where about of manhole cover and its health. In case of damage or theft, it will intimate the cloud-based server in real-time, and the server will alert the concerned officers or personnel about the same so that they can take the necessary action as soon as possible.

We are using LoRa nodes, accelerometer sensors, LoRa gateway, and TTN server. LoRa nodes and gateway are programmed and configured by using python. In the manhole cover monitoring system, the accelerometer sensors sense the damage and

theft of cover using angle algorithm periodically. When there is the movement of manhole cover, it alerts the LoRa board connected there. LoRa board transmit RF signal wirelessly in the unlicensed frequency band for long-distance. This signal is received by nearby LoRa nano-gateway which is connected to TTNserver. The data will be uploaded to the cloud and stored, and it will alert the maintenance department for repairing purpose. The block diagram of the system is as shown in Fig. 3.

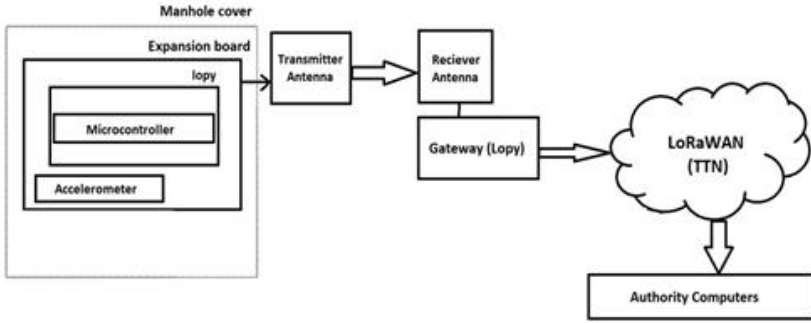


Figure 3. Block schematic of manhole cover monitoring system

During the implementation, we have used LoRa nodes from PyCom, which have inbuilt the accelerometer sensor [8]. The nodes are programmed by using micro Python and Pymakr. PyCom nodes can also be configured as single-channel nano gateways for LoRaWAN. We have programmed one of the nodes as LoRa nano gateway to receive the LoRa signal from sensing LoRa nodes and hence the health of manhole covers. The Nano gateway is connected to the Internet so that it can send data to the TTN server. On TTN server, we have configured an application to decode the data and integrated a service to send email and SMS. When the manhole cover is abnormal, it will send out an alarm message to notify the relevant departments to repair and realize the municipal manhole cover's periodical supervision. The proposed placement of the LoRa node on the manhole cover is as shown in Fig. 4. The process flowchart for the working is, as shown in Fig. 5.

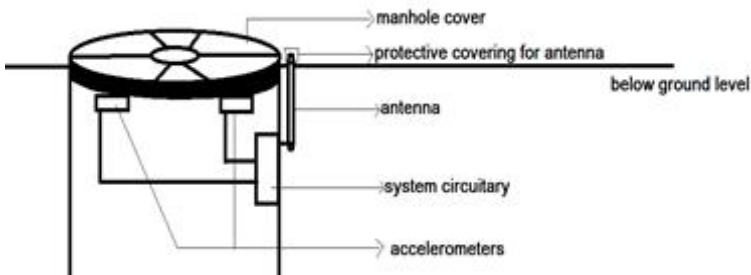


Figure 4. Placement of LoRa node on manhole cover

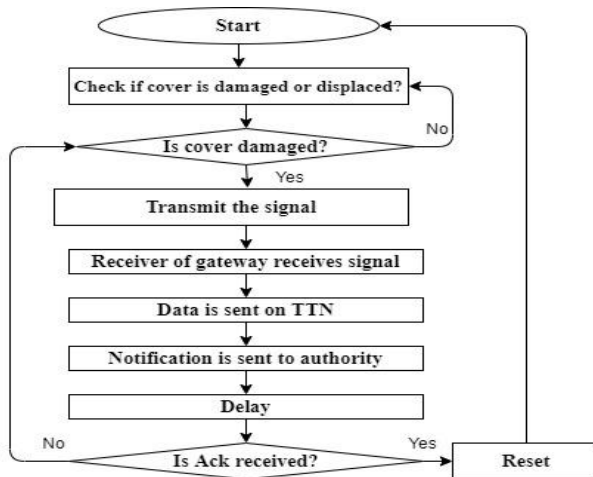


Figure 5. Process flowchart for manhole cover monitoring system

### 5. Conclusion

We propose the use of low-power long-distance LoRaWAN technology for manhole cover monitoring. This low cost and highly secured technology have the advantage of long-distance transmission with unlicensed band operation. In case of any damage, displacement or theft of manhole cover, the system immediately alerts the maintenance department for the corrective action. The system can avoid accidents as well as saves the lives of the citizens. This technology can be used for many smart cities and other applications for the betterment of society.

### References

- [1] Chaudhari, Bharat S. and Marco Zennaro, eds. LPWAN Technologies for IoT and M2M Applications. Academic Press, 2020.
- [2] Adelantado, Ferran, Xavier Vilajosana, Pere Tuset-Peiro, Borja Martinez, Joan Melia-Segui, and Thomas Watteyne. Understanding the limits of LoRaWAN, IEEE Communications magazine 55, no. 9, pp. 34-40, 2017
- [3] Chaudhari, Bharat S., Marco Zennaro, and Suresh Borkar. LPWAN technologies: Emerging application characteristics, requirements, and design considerations. Future Internet vol. 12, no. 3, pp. 46-71, 2020.
- [4] Zhang, He-sheng, Lei Li, and Xuan Liu, Development and test of manhole cover monitoring device using LoRa and accelerometer, IEEE Transactions on Instrumentation and Measurement. vol. 69, no. 5, pp. 2570-2580, 2020.
- [5] Bankov, Dmitry, Evgeny Khorov, and Andrey Lyakhov, On the limits of LoRaWAN channel access. In 2016 International Conference on Engineering and Telecom (EnT), pp. 10-14. IEEE, 2016.
- [6] <https://www.semtech.com/lora>
- [7] <https://www.thethingsnetwork.org/docs/index.html>
- [8] [www.pycom.io](http://www.pycom.io)
- [9] Ambeth Kumar.V.D .Precautionary measures for accidents due to mobile phone using IOT. Clinical eHealth, Volume 1, Issue 1, March 2018, Pages 30-35.
- [10] K. Sabarinathan et.al ., “ Machine Maintenance Using Augmented Reality”, 3rd International Conference on Communication and Electronics Systems (ICCES), 2018. (DOI: 10.1109/CESYS.2018.8723900)

# Li-Fi & Wi-Fi Based Drone for Weather Monitoring with Data Storage in Cloud Using IoT

Jayashree T R<sup>a,1</sup>, Priyadarshini K<sup>b</sup>, K. Sri Harini<sup>c</sup>,

<sup>a</sup>Assistant Professor, Dept of Aero, Rajalakshmi Engineering College, Chennai, India

<sup>b</sup>PG Scholar, Dept of Aero, Rajalakshmi Engineering College, Chennai, India

<sup>c</sup>UG Scholar, Dept of ECE, Easwari Engineering College, Chennai, India

**Abstract.** In this paper a Li-Fi and Wi-Fi-based weather monitoring system is built using drone. The atmospheric conditions are monitored using the drone and the gathered information is communicated to the ground station using Li-Fi technology. The process of transfer of information involves gathering data using sensors and transfer of data using Li-Fi technology. Data is processed and sent to the receiving station by using Light Fidelity technology. The received data is uploaded to a cloud data base using Wi-Fi technology. Real time data is displayed in an android device using IOT technology. Increased used of wireless communication which used Radio Frequency leads to RF congestion. Light Fidelity system is a best alternative by using a visible light instead of Radio frequency as used by all wireless communication system.

**Keywords.** Li-Fi, Internet of Things (IOT), Energy saving technology, Weather monitoring, Wi-Fi, Cloud storage, Sensors

## 1. Introduction

Basic Li-Fi technology consists of one power-controlled LED light and one receiver system to receive high frequency light illumination. Drones are incredibly refreshing now a day, the drones are appropriate for reconnaissance as it has numerous productive highlights. Drones have capacity to play out numerous capacities with or without controlling of human. It can possibly be utilized in far off detecting applications, observation and logical examination. The undertaking is centered on researching the limit of an affordable drone in observing an expansive and is sending back the information back to the person at the ground. The different sensors are presented in the flying drone that takes readings of moisture, temperature, elevation levels and pressing factor. The values are totally shared to the control station through Li-Fi and after that transferred to the cloud. Light Fidelity is another far-off correspondence advancement which enables a far-off data transmission.

---

<sup>1</sup>JayashreeTR, Assistant Professor, Dept of Aero, Rajalakshmi Engineering College, Chennai, India.  
Email: priyadarshini.k.2019.meav@rajalakshmi.edu.in



Light Fidelity relies upon an outstanding cutoff of strong state lighting systems to low and high with a LED blazing that's imperceptible for living vision information got by sensors with photo diode zone of bright perceivable quality.

## 2. Existing System

The available weather monitoring system uses radio waves to gather information. With traditional radio transmitter network access can before long be over-burden if huge information is sent, however in Light Fidelity technology information transfer rate consistently stays stable with additional wavelength in the white LED light. Radio waves cause adverse effects on the environment. RF pollution leads to carcinogenic effects on living organism. The data transfer is only through Electromagnetic radio waves or radio frequency which harms living being.

## 3. Proposed System

Important target of the proposed research, send data through light using LED while flying. The target of our thought is to use Li-Fi system (i.e.) to use LED light to transfer data and to screen the climate conditions such as temperature, humidity and altitude information, we gather the information's using drone and send the observed data from sensor to ground station with LiFi technology through LED light, after that the information will be transferred and store in the cloud utilizing Wi-Fi using IOT technology. The data are stored in the thing Speak cloud by MATLAB. The stored data will be displayed with time, date and location information. Data analysis of the transmitted data can also be viewed in the Cloud. An Excel report of the data can be downloaded from the cloud. In this Project we also prove this idea in a flying drone model.

## 4. Advantages of Proposed System

In this proposed system we are transmitting a data at a frequency of 1000 times of radio frequency spectrum through Li-Fi which cannot be hacked, to avoid this issue data are transmitted through Light Fidelity system. Information transfer rates up to 3 Gbits/sec. The fundamental benefit of this Light fidelity framework is no radiation emission, no obstruction with radio waves and it makes information security simple. We are minimizing the use of Radio frequency in which the radiation harms the living being health conditions. The data transmitted will be stored in a cloud with time, date, altitude, longitude, latitude, Humidity value and temperature value through IOT technology. So here Light-fidelity and Wireless-fidelity technology is used together in a drone for weather monitoring. Used for Weather monitoring, Top of Buildings, used in high region, used as alternative of Wi-Fi technology, Used as alternative for Radio Frequency.

### 5. Results and Discussions

In this project DHT11 and BMP180 sensor used for the weather conditions and altitude information sensing. Li-Fi is fitted on the drone to transmit the weather data. The receiver station is fixed on top of a building to receive the data from drone along with Wi-Fi to upload the data to the cloud. Photo-diode is used at receiver station to sense the light and convert it into data. Cloud storage can be accessed from anywhere in the world. Cloud storage displays the aggregate, live data analysis and visualization of data which has been uploaded by the receiver station. When the drone travels above the receiver station it sends the data to the receiver station of that area. An android app is used to display the data which has been stored in the cloud. LCD display has been used in both transmitter and receiver to check the accuracy of the transmitted data and received data.

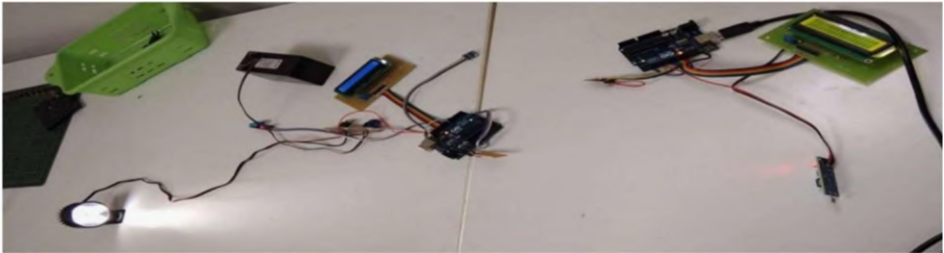


Figure 1. Data Transmission using Li- Fi technology

Figure.2 Drone is made up of Aluminum square material and Hylum sheet. Drone is tested with Li-Fi transmitter onboard and a receiver station with Wi-Fi is fixed on a building.



Figure 2. Drone Quad Copter with Li-Fi technology

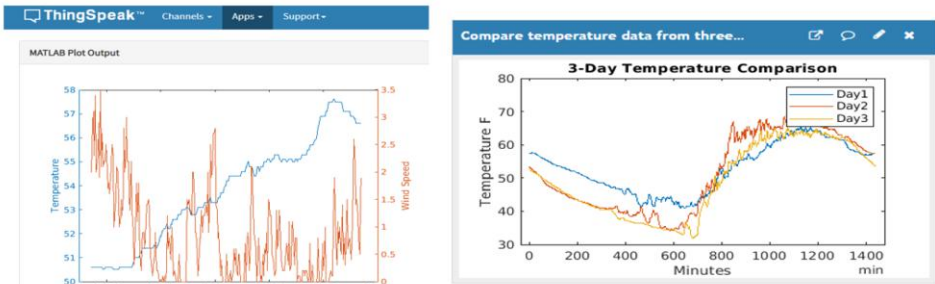


Figure 3. Wind speed prediction with temperature data and comparison analysis of temperature

Figure.4 Separate channel is created for this project in the MATLAB thingSpeak Cloud. The channel name is Drone-Monitoring using LiFi-WiFi Communication. This channel is a private cloud which can be accessed by only authorized user. Here we can store up to 128 GB data. ThingSpeak shows the Aggregate, Live data Analysis and Visualization of the data is shown in the form of graphical representation separately as Temperature, Humidity and Altitude data.



Figure 4. Data storage in cloud ThingSpeak using IOT

Time	Temperature	Humidity	Other Data
16 2021-03-27 10:51:52 IST	15	0	0
17 2021-03-27 10:52:38 IST	16	0	0
18 2021-03-27 10:54:11 IST	17	0	0
19 2021-03-27 10:55:59 IST	18	31	45
20 2021-03-27 10:58:15 IST	19	31	45
21 2021-03-27 10:58:48 IST	20	31	45
22 2021-03-27 10:59:23 IST	21	31	45
23 2021-03-27 10:59:54 IST	22	31	45
24 2021-03-27 17:00:13 IST	23	0	0
25 2021-03-27 17:04:26 IST	24	0	0
26 2021-03-27 17:08:34 IST	25	28	43
27 2021-03-27 17:07:53 IST	26	28	43
28 2021-03-27 17:10:08 IST	27	28	43
29 2021-03-27 17:10:41 IST	28	28	43
30 2021-03-27 17:11:14 IST	29	28	43
31 2021-03-27 17:13:47 IST	30	28	43
32 2021-03-27 17:12:20 IST	31	28	43
33 2021-03-27 17:13:53 IST	32	28	43
34 2021-03-27 17:13:26 IST	33	28	43
35 2021-03-27 17:13:59 IST	34	28	43
36 2021-03-27 17:14:32 IST	35	28	43
37 2021-03-27 17:15:05 IST	36	28	43
38 2021-03-27 17:15:38 IST	37	28	43

Figure 5. Downloaded weather report from Cloud ThingSpeak

Figure 6 Android mobile app (ThingView) is used to show the live data analysis and Visualize the data which has been stored in the ThingSpeak cloud

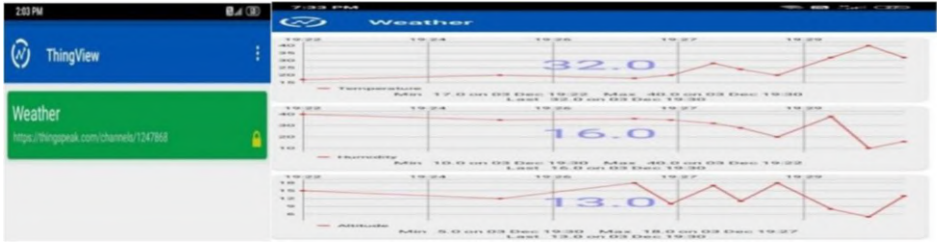


Figure 6. Weather report viewing in Thing View Free mobile app

## 6. Conclusion

Implementing Li-Fi technology in a flying drone to send data. In this system weather data and altitude information is successfully sent through Light Fidelity technology while flying and using Wireless Fidelity data are stored in the ThingSpeak cloud using Internet of things (IoT) technology. In this project Cloud Storage, Li-Fi, Wi-Fi & IoT technology are being used. In Future Weather forecasting, Weather prediction, Weather Alert Message and Wi-Fi replaced with Li-Fi in the receiver station can be done as future work.

## References

- [1] Wireless data from every light bulb Harald Haas, TED Global, Edinburgh, October 2011.
- [2] Cossu, G., Khalid, A. M., Choudhury, P., Corsini, R., and Ciaramella, E., 3.4 Gbit/s Visible Optical Wireless Transmission Based on RGB LED, *Optics Express* 20, B501–B506, 2012.
- [3] Khalid, A.M. Cossu., Corsini, R., Choudhury., and Ciaramella, E., 1-Gb/s Transmission Over a Phosphorescent White LED by Using Rate-Adaptive Discrete Multitone Modulation,” *IEEE Photonics Journal* 4, 1465–1473 (Oct. 2012).
- [4] Li-Fi Technology Transmission of data through light by Rahul R. Sharma, Raunak and Akshay Sanganal published in *International Journal of Computer Technology & Applications*, Vol. 5 (1), 150-154, 2014
- [5] What is LiFi by Harald Haas, Liang Yin, Yunlu Wang and Cheng Chen published in *Journal of Lightwave Technology*, 2015
- [6] Saputra and Mirdanias.M. Controlling unmanned ground vehicle via 4 channel remote control, in *Energy Procedia*, 2015
- [7] Rajbhandari.S, Chun.H, G. Faulkner, K. Cameron, A. V. N. Jalajakumari, R. Henderson, D. Tsonev, M. Ijaz, Z. Chen, H. Haas, E. Xie, J. J. D. McKendry, J. Hermsdorf, E. Gu, M. D. Dawson and D. O’Brien, High-speed integrated visible light communication system: Device constraints design considerations, *IEEE J. Sel. Areas Commun.*, vol. 33, no. 9, pp. 1750- 1757, 2015
- [8] Hodgson.J.C, Baylis.S.M, R. Mott, A. Herrod, and R. H. Clarke, Precision wildlife monitoring using unmanned aerial vehicles, *Sci. Rep.*, 2016.
- [9] Wasio O. Popoola, Impact of VLC on Light Emission Quality of White LED’s, *Journal of light wave technology*, vol. 34, no. 10, may 15, 2016
- [10] Li-Fi: The Future Bright Technology by Akanksha R. Shrivastava published in *Special Issue of International Journal of Electronics, Communication & Soft Computing Science and Engineering*, 2017
- [11] Alvear.O, Zema.N.R, Natalizio.E and Calafate.C.T . Using UAV-based systems to monitor air pollution in areas with poor accessibility, *J. Adv. Transp.*, 2017.
- [12] Nanagasabapathy.K et.al, Validation system using smartphone luminescence, *IEEE International Conference on Intelligent Computing, Instrumentation and Control Technologies (ICICICT)*, Pages: 235 – 239, 6-7 July 2017, Kannur, India

# MRI Brain Abnormality Detection Using Conventional Neural Network(CNN)

Jeevitha R<sup>a,1</sup> and Selvaraj D<sup>b</sup>

<sup>a</sup>PG Scholar, Dept of ECE, Panimalar Engineering College, Chennai, India

<sup>b</sup>Professor, Dept of ECE, Panimalar Engineering College, Chennai, India

**Abstract.** Brain tumours has huge heterogeneity and there is always a familiarity between normal and abnormal tissues and hence the extraction of tumour portions from normal images becomes persistent. In this paper, MRI brain tumor detection is performed from a brain images using Fuzzy C-means(FCM) algorithm and subsequently Convolutional Neural Network(CNN) algorithm is employed. Here, firstly preprocessing step is performed by Skull Stripping algorithm followed by Segmentation process. Fuzzy C-means algorithm is used to segment the Cerebrospinal Fluid(CSF), Grey matter(GM) and White Matter(WM) from the database. The third part is to extract features to find whether the tumor is present or not, here eleven features are extracted like mean, entropy, S.D(Standard Deviation). The final part is the classification process done by Convolutional Neural Network(CNN) in which it is able to differentiate whether the input image is normal image or an abnormal image. Compared to other methods, here the values of the features extracted are higher for normal images than for abnormal Images and it is shown from the graphs drawn from the extracted features.

**Keywords.** Fuzzy C-means, Convolutional neural network, Skull stripping, CSF, GM, WM, ROI.

## 1. Introduction

Magnetic resonance imaging (MRI) is a medical imaging technique utilized in radiology to make pictures of the anatomy and physiological processes of the body. MRI detects various problems like tumours, swelling, cysts, bleeding, infections, problems with the blood vessels, developmental and structural abnormalities and inflammatory conditions which are spread of conditions of brain. MRI can also tell if a shunt(small passage or hole) is working and finds whether the brain is damaged by any stroke or injury. Chronic diseases of the system a nervosum, like MS(Multiple Sclerosis) can also be detected. It can also provide images that cannot be identified even by CAT scan, X-ray, ultrasound in regions of brain, especially diagnosing defects and deficiencies in brain stem and pituitary glands. So here, MRI brain images are being employed and detected whether the given image is normal or abnormal using segmentation and classification methods.

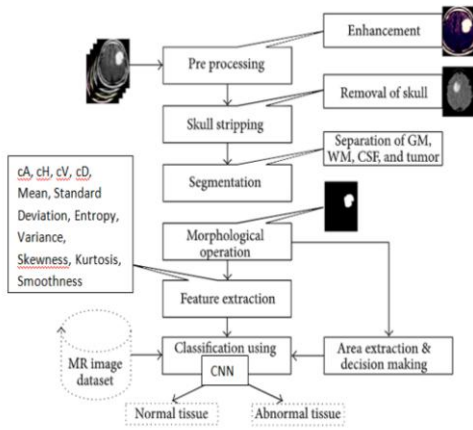
---

<sup>1</sup>Jeevitha R,PG scholar , Dept of ECE, Panimalar Engineering College, Chennai;  
E-mail: jeevs15.rj@gmail.com

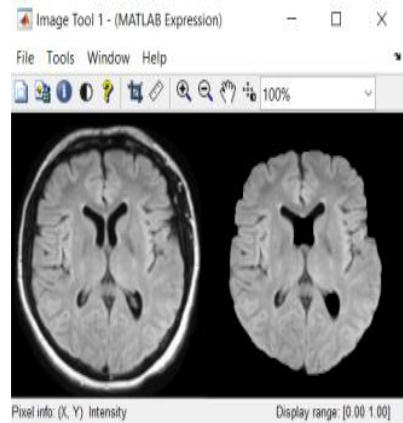
## 2. Related works

Sofiane tchoketch kebir et.al[1] has proposed a supervised and automatic MRI Brain abnormalities detection procedure drew on raw MRI images of brain using CNN deep learning network and K-means algorithm. Tonmoy Hossain et.al[2-3] and Qi Dou et.al[4-7] presented a novel automatic method to detect CMBS from magnetic resonance (MR) images by exploiting the 3D convolutional neural network (CNN). Yu Zhao et.al[8-9] presented a deep 3D CNN structure for effective, accurate and automatic classification and identification of huge number of functional brain networks reorganize by scanty potrayal of total brain fMRI signals. Jinglong du et.al[10] proposed a different and new dilated convolutional encoder-decoder (DCED) network to enhance the resolution of MRI .

## 3. Proposed method



**Figure 1.** Block diagram for proposed Brain image classification using CNN



**Figure 2.** Skull stripped

Figure 1 shows how the flow of the proposed system goes. Here, the MRI image set is first preprocessed and removal of skull is performed by skull stripping. Then segmentation is performed by Fuzzy C means algorithm for CSF, WM and GM Segmentation. After the morphological operation is done, features are extracted for getting ROI(Region Of Interest) region and to classify whether the tumor is present or not. Finally, classification using(CNN) is done to classify normal and abnormal images. Skull stripping being a preliminary step, designed to eliminate non-brain tissues from MR brain images. FCM is a sort of clustering during which each datum can belong to one cluster. The technique of extracting the features is useful when a huge data set is used and need to reduce the number of resources without losing important or relevant information. Here, eleven features are extracted namely cA(Approximation Coefficient), cH, cV, cD(horizontal, vertical, diagonal detail coefficients), Mean, Entropy, Variance, Standard Deviation, Skewness, Smoothness, Kurtosis. DWT(Discrete Wavelet Transform) and GLCM(Grey Level Co-occurrence Matrix) are used for Feature Extraction.

#### 4. Brain classification using CNN

The main advantage of this network is that it is often used for a giant set of datasets and more data are often trained. It uses smaller parameters related to a totally combined network by reclaiming an equivalent parameter several times.

- $cA = \text{mean2}(cA)$ ;
- $cH = \text{mean2}(cH)$ ;
- $cV = \text{mean2}(cV)$ ;
- $cD = \text{mean2}(cD)$ ;
- $\text{Mean} = \text{mean2}(J)$ ;
- $\text{Standard\_Deviation} = \text{std2}(J)$ ;
- $\text{Entropy} = \text{entropy}(J)$ ;
- $\text{Variance} = \text{mean2}(\text{var}(\text{double}(J)))$ ;
- $\text{Smoothness} = 1 - (1/(1+a))$ ; [ $a = \text{sum}(\text{double}(J(:)))$ ];
- $\text{Kurtosis} = \text{kurtosis}(\text{double}(J(:)))$ ;
- $\text{Skewness} = \text{skewness}(\text{double}(J(:)))$ ;

Here, the features are calculated for 40 images from the above mentioned formulas.

#### 5. Results And Discussion

First, the algorithm is applied to an abnormal image and preprocessing is applied. Then, segmentation is carried out followed by classification using CNN after features are extracted.

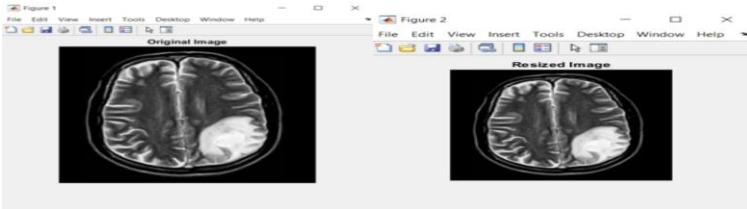


Figure 3. Abnormal image

Figure 4. Resized image

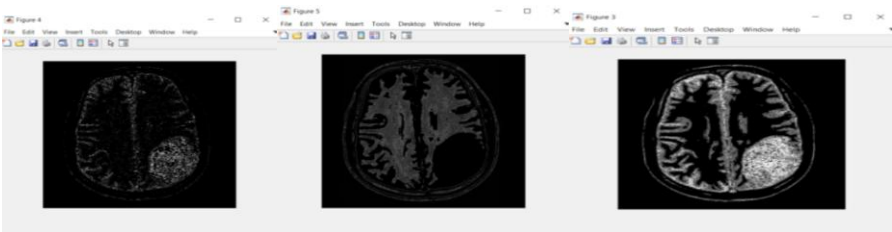


Figure 5. CSF, GM, WM Segmentation

Figure 3 shows the Abnormal image. Figure 4 shows the resized image of the Abnormal image. Figure 5 shows the segmentation of CSF(Cerebrospinal fluid), GM(Grey matter) and WM(White matter) using Fuzzy C means algorithm. Figure 6 shows the ROI region where the tumour is isolated without noise. Figure 7 shows the tumour cropped region from the original image and figure 8 shows a dialog box stating tumor is present. Now, the same process is applied to a normal image.

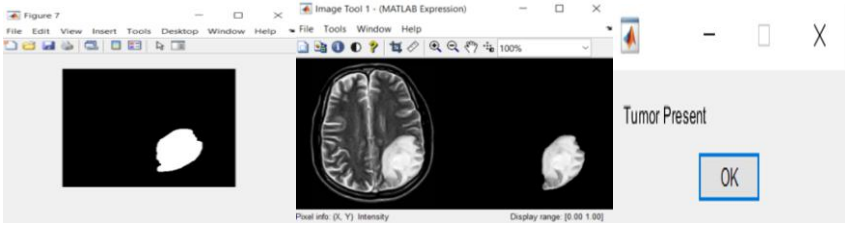


Figure 6. ROI image

Figure 7. Tumour presented image

Figure 8. Dialog box

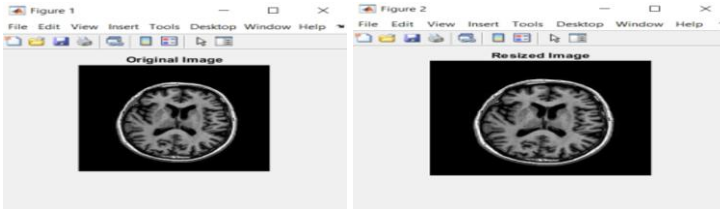


Figure 9. Normal image

Figure 10. Resized normal image

Figure 9 shows the normal image of the normal tissue. Figure 10 shows the resized image of the normal image.



Figure 11. Dialog box

Figure 11 shows the dialog box stating that the image is normal without any tumor. The below graphs are plotted based on the values calculated from the feature formulas. The below table shows the accuracy comparison table between the existing method (ANN) and proposed(CNN) method.

Table 1. Comparison table between existing and proposed method

Classification methods	Accuracy
Existing method(ANN)	92.7%
Proposed method(CNN)	95.5%

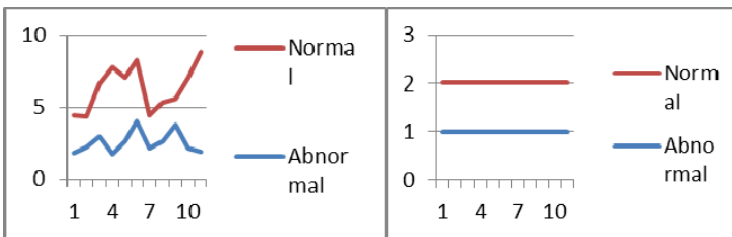


Figure 12. Comparison graph for Mean

Figure 13. Comparison graph for S.D(Standard Deviation)



Figure 12 and figure 13 shows the graph for Mean and Standard Deviation(S.D) for both normal and abnormal images. Similarly, graphs have been plotted for all the remaining features too. All the graphs denote that the values are higher for normal images than abnormal images.

## **6. Conclusion**

In this proposed work, different sizes of MRI Brain images have been used and done preprocessing to remove skull. Segmentation is done by Fuzzy C-Means algorithm to segment CSF, GM and WM Regions. And 11 features are extracted to find the Region Of Interest region to find whether tumour is present or not. Here, it has classified the normal and abnormal images by Convolutional Neural Network(CNN) and shown that the extracted features values like mean are higher for normal images than abnormal images. So, here the algorithm is able to differentiate whether a image is normal image or abnormal image and has achieved 95.5% accuracy. In future, the calculated feature will be used to train NN(Neural Network) to identify the given input image.

## **Reference**

- [1] Tonmoy Hossain et.al, Brain Tumor Detection Using Convolutional Neural Network , IEEE Transactions on Medical Imaging 2017.
- [2] Sérgio Pereira et.al, Brain Tumor Segmentation Using Convolutional Neural Networks in MRI Images , IEEE Transactions On Medical Imaging, Vol. 35, No. 5, May 2016.
- [3] Masoumeh Siar et.al, Brain Tumor Detection Using Deep Neural Network and Machine Learning Algorithm”, IEEE Transactions on Neural Systems & Rehabilitation Engineering, vol. in press, 2018.
- [4] Madhupriya G et.al, Brain Tumor Segmentation With Deep Learning Technique”, IEEE Xplore Part Number: CFP19J32-ART; ISBN: 978-1-5386-9439-8(2019).
- [5] Zijian Wang et.al, Dilated 3D Convolutional Neural Networks for Brain MRI Data Classification , IEEE Access(2019).
- [6] Lin Yuan et.al, Multi-center Brain Imaging Classification Using A Novel 3D CNN Approach , IEEE Access, vol. 32 no. 2, 2018.
- [7] Selvaraj, D., and Dhanasekaran, R. (2013), A Review on Current MRI brain tissue segmentation, Feature Extraction and Classification Techniques , International Journal of Electronics, Communication and Instrumentation Engineering Research and Development, Volume 3, Issue 5, PP.11-30.
- [8] Selvaraj, D., and Dhanasekaran, R. (2013), Segmentation of Cerebrospinal Fluid and Internal Brain Nuclei in Brain Magnetic Resonance images , International Review on Computers and Software, Volume 8, Issue 5, PP. 1063-1071.
- [9] Selvaraj, D., and Dhanasekaran, R. (2015), Combining Tissue segmentation and neural network for brain tumour detection , International Arab Journal of Information Technology, Volume 12, Issue 1.
- [10] Jeevitha R et.al, Segmentation techniques for Brain tumor from MRI - A Survey, Advances in Parallel Computing Journal[IOS-Press], Scopus, doi: 10.3233/APC200181.

# Investigation and Suppression of RF Leakage Power in Front End Wireless Devices

Kanchana Devi A<sup>a,1</sup> and Bhuvaneshwari B<sup>b</sup>

<sup>a</sup>PG Scholar, Dept of ECE, Panimalar Engineering College, Chennai, India

<sup>b</sup>Professor, Dept of ECE, Panimalar Engineering College, Chennai, India

**Abstract.** In this modern Communication Wireless System, Frequency Division Duplex (FDD) is mostly used. Duplex is a device to separate Transmitter and Receiver signals. Transmitter or Power leakage causes from limited isolation performance of the duplexer. Various Techniques of Modulation using Orthogonal Frequency Division Multiplexing (OFDM) provided better solution to cancel this leakage. The OFDM provides high spectral efficiency, lower multi-path distortion and to eliminate inter symbol interference (ISI). Fast Fourier Transform implemented modulation and demodulation functions more efficiently. Using simulation result of the various parameters are analysed. In addition, Comparison of the table between Bit rate error value, Signal strength throughput, Power consumption and Mean square error values obtained in the OFDM systems.

**Keywords.** FDD, OFDM, ISI, BPSK, QPSK, 16-QAM, SNR, MSE and Power spectral density.

## 1. Introduction

In Communication System, the input streams are modulated in carrier frequency. The available spectrum bandwidth occupied fully by each of every symbol. This leads to inter-symbol-interference (ISI). OFDM gives sufficient robustness using larger data rates to radio channel [1]. In the world many researcher teams are working under OFDM system optimization. Block diagram of FDD transceiver is shown in figure 1. Since an FDD transceiver both transmit and receive at the same time, the function of duplex filter is connected the TX and RX to the same antenna [2]. The duplex TX/RX isolation is not infinite and it results in a leakage signal at the receiver input. Radio receiver circuit, the circuit between antenna and mixer called RF Front End Module. It consisted all the components in receiver processed the original signal before converted to lower intermediate frequency (IF). It is used to detect, band limiting and amplifying the received RF signals. RF amplifier needed to strength weak signals that are received increasing the amplitude of the RF signals that are weak[12].

---

<sup>1</sup>Kanchana Devi. A, PG Scholar, Dept of ECE, Panimalar Engineering College, Chennai, India, E-mail: akanchanadeviselvi@gmail.com.

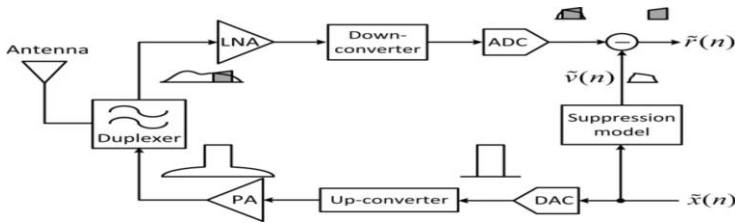


Figure 1. TX leakage at the receiver in FDD transceivers.

This circuit is embedded with low-noise trans-conductance amplifier (LNTA). Finally noise and distortion are minimized using the proposed circuit design model[6-7]. Andreas Gebhard et al.,(2019) proposed an algorithm using nonlinear type Recursive Least Square based Adaptive filter and its robust version cancelled the interference of the intermodulation distortion using second order. Here leakage of transmitter signal suppressed using stopband of frequency selective duplex[8]. H. Khatri et al.,(2010) and A. Cicalini et al.,(2006) proposed TX leakage filtering active cancellation techniques[9-11]. Lederer and Huemer (2011), Frotzschner and Fettweis (2008), and Kahrizi et al.,(2008) discussed interference cancellation algorithms using adaptive based LMS and measured error to suppress noise through stopband of the frequency flat duplex[12-13].

## 2. Proposed work

### 2.1 OFDM Model

The block diagram of communication wireless systems to transmit and receive data using more number of components required. Digital modulation technique is one of the important modules. This modulation allowed digitized data to be transmitted to the channel of the radio frequency. For without a break in continuity from this communication maintained using high transmission rate. MODEM provided fast and lossless transmission rate of data efficiently. Figure1 showed block diagram of proposed system. The required spectrum based on input data stream and modulation technique chose using OFDM system. Each carrier transmitted the assigned data. Using modulation techniques are required amplitude and phase of the carrier(i.e., BPSK, QPSK, or QAM). The required spectrum is then converted from frequency to time domain signal using an Inverse Fast Fourier Transform.

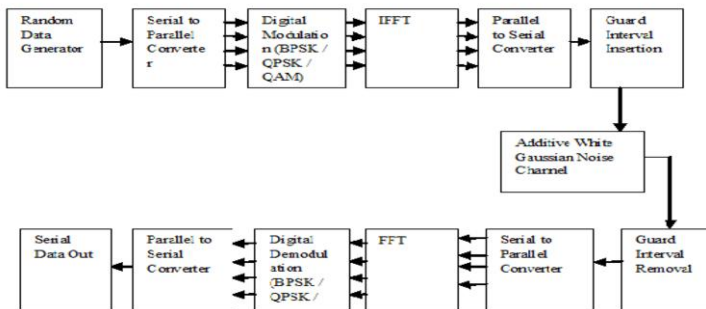


Figure 2. The proposed model used for simulation

### 2.2 Modulation Techniques

In Day by day changing Communication System faces a problem of provided quality of services high with transmission errors are low. To overcome this problem using OFDM technology provided. BPSK and QPSK modulation techniques are used interleaving function. It is reduced the rate of transmission bit error. The transmission error rate of AWGN channel using QPSK and BPSK modulation have less bit error rate and also throughput of the signal strength is increased. Power consumption is consumed low power in this system. QAM is combination phase and amplitude. In higher-order constellation, it transmitted more number of Transmitted bits. The mean energy of the constellation are remained same. The points are closed together and it provided susceptible to noise and interference are high. In this three techniques we calculated error rate, increased throughput and minimize the power consumption also.

### 3. Results and Discussion

The data signal follows BPSK based on OFDM with 32 sub carriers, a fast fourier transform of size 64, 48 for data and 4 for pilots. The BER is computed on bits of the data and through an AWGN channel with various SNR. We considered that the noise plus signal is caused by RF Leakage and that signal has transmitted using same technique modulation parameters. The bit error rate is calculated using comparison of the input data stream from a transmitter to the input data stream from a receiver. SNR is done by the difference of signal and noise power. The results of the BER for various iteration of the same channel SNR. It is shown that the transmitter Leakage outcome performance and reduced consequence of this interference. Simulation of OFDM based QPSK was same setup function of BPSK based OFDM model. The only difference is that instead of BPSK modem replaced by the QPSK modem functions. Simulation of OFDM with 16-QAM modulation technique is combination of PSK and ASK. As usual BPSK technique, we calculated the parameters values, the same way QPSK and 16-QAM same parameters values are calculated and mentioned below tables. The input data and channel model are same.

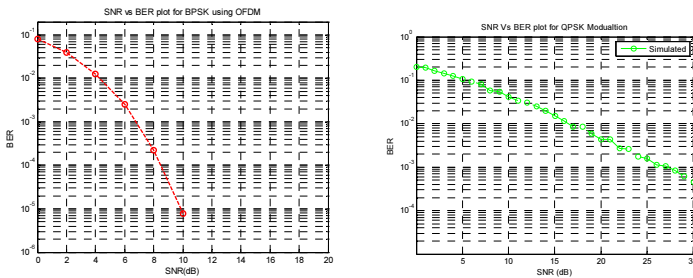


Figure 3. BER versus SNR curve for OFDM with BPSK and QPSK

From the graphical results (Figure 3), SNR values in dB are changed depending upon time in the Additive White Gaussian Noise channel. SNR value is calculated and their corresponding probability of error is also measured and tabulated. As we increased the SNR value, bit error rate reduced.

### 4. Performance Comparison

Comparison of the various parameters values are mentioned in the below table using OFDM system modulation technique. From the results, it was observed that the BPSK allowed very low error transmission rate. Because it is used only two bits. In QPSK modulation, the throughput of the signal strength is increased compared to others. QAM is more susceptible to noise so they have a higher BER and compare to QPSK. So Signal to noise ratio is increased high in QPSK modulation compared to other techniques.

TABLE 1. Various parameter performance for OFDM model

S.No	Modulation	SNR(dB)	BER	MSE	PSD
1.	QPSK	33	0.2102	2.50	1.79
2.	BPSK	11	0.0802	1.73	1.60
3.	16QAM	20	0.5016	2.57	1.34

The various parameters are mentioned in table and also plotted graphical form of different techniques(Table 1, Figure 4). From the table shown QPSK is suppressed leakage of improving signals strength. In receiver side we got high throughput that meant transmission rate error was cancelled. Power consumption of this system value is 1.79 and Signal power noise ratio value is 33.

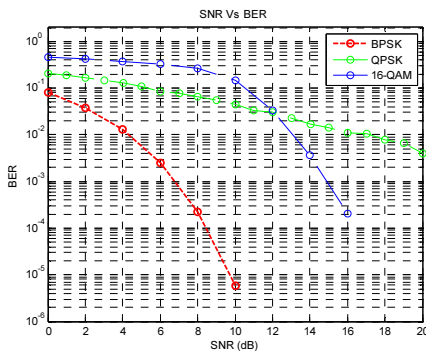


Figure 4. Comparison of Graph of BPSK, QPSK and 16-QAM.

### 5. Conclusion

Modulation and demodulation function is an important function in any communication system. It is decided the quality of the entire communication system. The proposed concept reduced the power consumption in the RF system and also increased throughput of the signal during reduced parity bit errors. OFDM was performed for different technique of digital modulation namely BPSK, QPSK and 16-QAM using FFT transform technique. From the results, BPSK allowed the Bit Error Rate improved in a noise channel data transmission capacity was maximized. Using QPSK allowed

high transmission throughput. Therefore OFDM based QPSK required large transmission power. In this results, using OFDM with QPSK was more benifit for small distance of the link transmission. Otherwise OFDM based BPSK preferred. QAM is more susceptible to noise so they have a higher BER and compare to QPSK. So Signal to noise ratio is increased high in QPSK modulation compared to other techniques. Some more parameters also tabulated to analyse performance of three modulation techniques to minimize noise and increase SNR values.

## References

- [1] Cicalini et.al., An integrated LMS adaptive filter of TX leakage for CDMA receiver front ends, *IEEE J. Solid-State Circuits*, vol. 41, no. 5, pp. 1171–1182, May 2006.
- [2] Frotzscher and G. Fettweis, A stochastic gradient LMS algorithm for digital compensation of Tx leakage in zero-IF receivers, in *Proc. Veh. Technol. Conf. (VTC Spring)*, pp. 1067–1071, May 2008.
- [3] Khatri.H, Gudem.P, and Larson.L, An active transmitter leakage suppression technique for CMOS SAW-less CDMA receivers, *Solid- State Circuits, IEEE J. of*, vol. 45, no. 8, pp. 1590–1601, 2010.
- [4] Lederer and M. Huemer, LMS based digital cancellation of second order TX intermodulation products in homodyne receivers, in *Proc. IEEE Radio Wireless Symp. (RWS)*, pp. 207–210, Jan. 2011.
- [5] Frotzscher, G. Fettweis, Digital compensation of transmitter leakage in FDD zero-IF receivers, *Trans. Emerging Telecommun. Tech*, vol. 23, no. 2, pp. 105-120, March 2012.
- [6] Lauri Anttila, Mikko Valkama Digital Suppression of Power Amplifier Spurious Emissions at Receiver Band in FDD Transceivers, *IEEE Signal Processing Letters*, Vol. 21, No. 1, January 2014.
- [7] Jin Zhou et al., Low-Noise Active Cancellation of Transmitter Leakage and Transmitter Noise in Broadband Wireless Receivers for FDD/ Co-Existence, *IEEE Journal Of Solid-state Circuits*, Vol. 49, No. 12, December, 2014.
- [8] Chao Yu, Wenhui Cao et al., Digital Compensation for Transmitter Leakage in Non-Contiguous Carrier Aggregation Applications with FPGA Implementation.*IEEE Transactions On Microwave Theory And Techniques*, Vol. 63, No. 12, December 2015.
- [9] Z. Fu, L. Anttila, M. Abdelaziz, M. Valkama, and A. M. Wyglinski.Frequency-selective digital predistortion for unwanted emission reduction. *IEEE Trans. Commun.*, vol. 63, no. 1, pp. 254–267, Jan. 2015.
- [10] Wenhui Cao et al..Digital suppression of transmitter leakage in FDD RF transceivers: Aliasing elimination and model selection. *IEEE Transactions On Microwave Theory And Techniques*, 2017.
- [11] Daniele Montanari, Giacomo Pini et al.,.An FDD Wireless Diversity Receiver with Transmitter Leakage Cancellation in Transmit and Receive Bands. *IEEE Journal Of Solid-state Circuits*, Vol. 53, No. 7, July 2018.
- [12] Satheesh Bojja Venkatakrishnan, Elias A. Alwan et al., Wideband RF Self-Interference Cancellation Circuit for Phased Array Simultaneous Transmit and Receive Systems. *IEEE Journal*, Vol 6, 2018.
- [13] Andreas Gebhard, Christian Motz et al..A Robust RLS Type Adaptive Filter for Second-Order-Intermodulation Distortion Cancellation in FDD LTE and 5G Direct Conversion Transceivers.*IEEE Transactions On Microwave Theory And Techniques*, Vol. 67, No. 5, May 2019.
- [14] Kanchana devi.A , Bhuvaneshwari.B. A Study on Massive MIMO 5G Challenges. *Advances in Parallel Computing Journal [IOS-Press]*, Scopus, DOI: 10.3233/APC200179.
- [15] Nivetha.S.B,Bhuvaneshwari.B .Investigation of Meandered Antenna for WLAN Application. *Advances in Parallel Computing Journal [IOS-Press]*, Scopus, DOI: 10.3233/APC200167.

# Smart Industry Monitoring and Controlling System Using IoT

Elumalai. G<sup>a,1</sup>, Nallavan. G<sup>b</sup> and Ramakrishnan. R<sup>c</sup>

<sup>a</sup>Assistant Professor, Dept of ECE, Panimalar Engineering College, Chennai, India

<sup>b</sup>Associate Professor, Dept of ECE, TNPESU, Chennai, India

<sup>c</sup>Professor, Dept of ECE, TNPESU, Chennai, India

**Abstract.** Air pollution in an ecosystem has proliferated industrial automation. This dissertation concentrates more on industrial automation and has design an embedded device with sensors to monitor and control the toxic gases in industries. This entire prototype is an excellent result for observing the toxic gases in industry and generates information by using data acquisition and transmission of data. “Internet of Things (IoT)” is a important technology behind this and it provide platform to bring together all the devices in the world to the internet. In this dissertation, the parameters monitored are temperature, humidity and gas leakages in industries. The sensor senses the parameters and uploads these data to the cloud with the help of NodeMCU. If observed gas level is above the threshold which is the safety limit of operation, the first alert is intimated from the Google cloud and the controlling action carried out (ie) automatically close gas leakage valves and then industry will take immediate step to control pollution. Or else, the second alert message is sent through Electronic mail (e-mail) to restore the safe limit, as government play role to power outage in the industries. Cloud is used to store the sensed data, which is then transmitted and processed.

**Keywords.** Air pollution, Toxic gases, ECO-system, ESP8266 and IoT.

## 1. Introduction

In the recent years wireless technology and IoT grasped the most industrial area especially automation and control has increasing for need of upholding various sectors. Healthcare has prime importance in our day to day life. This paper reviewed about new industrialization with ESP8266 and arduino UNO. Indoor Air Quality (IAQ) is highly worsens industrial environments, which then spreads from indoor to outdoor, creating a large scale effect around the industrial areas. Long term and short term effects caused by Air pollution causes the people to concern about the air they breathe. The effect of air pollution from industry is monitored scarcely. Our aim is to monitor the air pollution from the heavy industry which leads to undesirable effects on the health of human beings and also affects the environment. Pollution level in comparison to the ambient air quality standards can be done by using monitoring. To protect the people against extreme air pollution. Robust monitoring systems are necessary to alert people and initiate actions.

<sup>1</sup>Elumalai.G, Assistant Professor, Dept of ECE, Panimalar Engineering College, Chennai, India.  
E mail: elumalaig@gmail.com

## 2. Review of Related Literature

Kavitha.B.C et al. (2019), insists on using intelligent sensors for pollution monitoring. Collected data from the sensors are sent to the Google cloud makes it possible to monitor the air pollution from anywhere in the world. In case of threatening levels of air pollution, alerting is used. This is used in industry and the pollution by vehicular emissions. Rajalakshmi.R et al. (2019), Observes the toxic gases present in the air to ensure the safety of the people in that environment and make it available at any place in the world for monitoring. The composition of chemicals in air like carbon monoxide, LPG, methane and flammable gases is monitored using sensors and this data is sent to the cloud server, which is then represented pictorially for better understanding of the statistics. Rupali et al. (2018), cares for home and industrial safety using fire and gas detection systems. This system detects the leakage of gas and fire using sensing circuit, which is then controlled by microcontroller which in turns triggers the alarm system to alert the leakage of gas and fire. Using GSM modems, SMS are being sent to notify the user. In addition, it is designed with mechanism to sprinkle the water using water sprinkler when there is a fire or gas leakage. MQ-6 and MQ-9 used as gas sensors to detect the gas leakage. IR flame sensor is used for fire detection, which detects the fire and notifies the user using SMS. Manish Verma et al. (2018), uses microcontroller based system to investigate about the toxic gas detection and alerting system. LCD display is used where the levels of hazardous gases like LPG and propane was displayed each second. Authorized person is notified with email and also using alarm generation mechanism. This automated detection and alerting mechanism helps to resolve the problem as soon as possible. Angelica Nieto Lee et al. (2018), this paper focuses on integrating all the contextual data, to provide accurate and relevant information as per the need. System information that already exists but has not been integrated into the monitoring system like 3D models and manuals. It is context aware industrial monitoring systems, which provide information based on system state, environmental conditions and functionalities of the devices in that environment. Ishwarya et al. (2018), insisted on automation of many small tasks around us using Internet of Things (IoT) in order to improve the quality of living. IoT is used for enhancing existing safety standards, using automation process. Gas leakages in open or closed areas can prove to be dangerous and fatal. Traditional gas leakage systems can able to detect the leakage but cannot able to alert the user. Alerting System can be established to alert the authorized person and to perform the data analytics from the obtained readings.

## 3. Proposed System

The figure 1 below shows the block diagram and prototype of the proposed system. The components used to design the hardware are Arduino UNO, Semiconductor sensor (MQ6 & MQ7), ESP8266, Relay , Power supply. MCP3008 is an analog to digital convertor. Analog values from the sensors are given to MCP3008, which is an 8 channel ADC, that converts the analog data to digital data which is then sent to NodeMCU. The parameters are monitored using DHT11, MQ-6, and MQ-7 sensors. The sensor senses their parameters regarding the temperature, humidity and gas level and uploads these data to the cloud with the help of WiFi device (NodeMCU). If the level of the gas reaches above the normal level, the first alert is intimated from the



Google cloud as it is automatically closes gas leakage valve and then industry will take immediate step to control pollution. Or else, the second alert message is sent through Short Message Service (SMS) to restore the safe limit intended so and as government play role power outage in the industries.

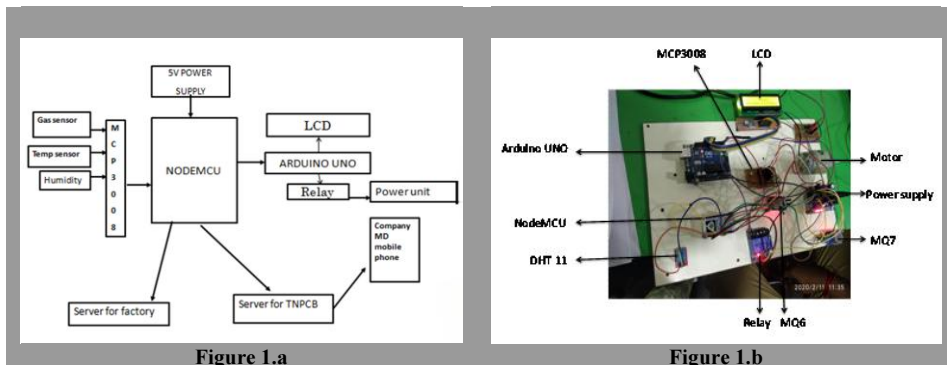


Figure 1. Block diagram and prototype of the proposed system

#### 4. Result and Discussion

We are going to test our prototype for different cases are discussed below. For our analysis Gas-1 represents carbon monoxide (CO), Gas-2 represents Isobutane, Propane, Liquefied Natural Gas (LNG) and Methane. Temp represents temperature. Humi represents humidity. Status represents either normal or emergency based on the industrial gas leakage level.

##### Analysis for Gas-1

In the figure 2.a, the permissible level of Gas-1 is below 300. In this case, Gas-1 does not reaches permissible level, so it is not harmful to the environment. Hence the status is normal. In the figure 2.b, the permissible level of Gas-1 is above 300. In this case, Gas-1 reaches above permissible level so it is harmful to the environment. Hence the status is emergency.

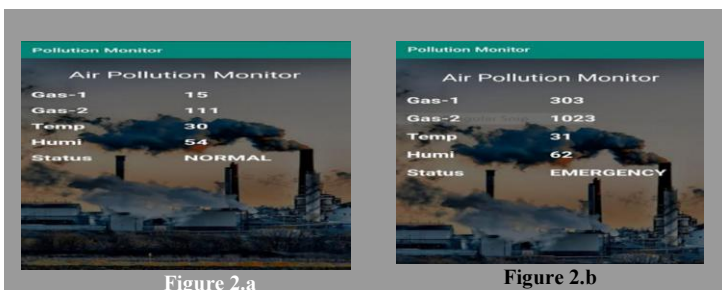


Figure 2. Output of Gas-1

### Analysis for Gas-2

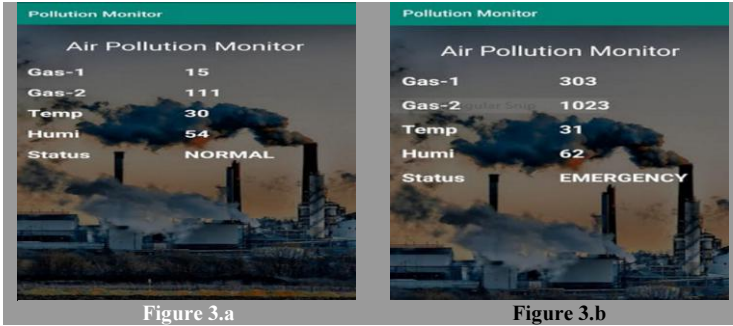


Figure 3. Output Gas-2

In the figure 3.a, the permissible level of Gas-2 is below 300. In this case, Gas-2 does not reach above permissible level so it is not harmful to the environment. Hence the status is normal. In the figure 3.b, the permissible level of Gas-2 is above 300. In this case, Gas-2 reaches above permissible level so it is harmful to the environment. Hence the status is emergency.

## 5. Conclusion

In this paper smart Industry Monitoring system based on IoT is proposed which can effectively monitor and control with alert. A prototype based on Arduino UNO was developed which could sense the concentration of gases. The real time data information obtained from the different sensors has been uploaded to Google Cloud which is displayed in the LCD. In addition to this other parameters like temperature, humidity was measured. Provision was also made to be vigilant the workers in case of any emergency. The system provides consistently and accurate analysis to prevent any case of accidents. This system makes use of Arduino UNO providing cheap solutions for safety. Slight modification of the model enables the user to adapt it to any environment. Predictive maintenance is an upcoming industrial need, for which the proposed model can be improvised. In case of gas leakage the concentration of gas varies from point to point which has to be analyzed. Moreover, the gases diffusing out during leakage may also combine among themselves producing other by products which have to be dealt in detail.

## 6. Future Scope

This prototype helps the industrial site from gas leakage deduction and faster resolution of problems afforded by a higher level of expertise focused on control system. This methodology could be applied to monitor distribution network of natural gas as well as industrial, commercial, residential gas pipelines in order to provide a safe operation and to avoid severe human health injuries caused by gas leakages. Proposed solution can act as an automatic vehicle health feed for manufacturer to improve their quality by providing regular vehicle services.

## References

- [1] Kavitha.B.C, Vallikannu.R . IoT based intelligent industry monitoring system. International Conference of Signal Processing and Integrated Networks, 2019
- [2] Rajalakshmi.R, Vidhya.J .Toxic environment monitoring using sensors based on IoT. International Journal of Recent Technology and Engineering, 2019.
- [3] Rupali, S.Gajare, P.Mahajan .Home and industrial safety system for fire and gas leakage detection. International Research Journal of Engineering and Technology, 2018.
- [4] PathRastogi ,DikshaTripathi .Gas leakage detection and prevention kit provision with IoT. International Research Journal of Engineering and Technology, 2018.
- [5] IshwaryaGawali, V.Nayakwadi, PriyankaRajmanes .Gas leakage detection and smart alerting system using IoT. International Journal of Innovative Research in Science, 2018.
- [6] V.Goulao, R Paulo, J Salvado, G Martins, A Granjeia, A new monitoring and data logger system for industrial cooling equipment application, Institute Of Electrical And Electronics Engineers , 2017.
- [7] Mohammed Y Aalsalem, NasrullahArmi .Intelligent oil and gas well monitoring system based on IoT .Institute Of Electrical And Electronics Engineers. 2017.
- [8] KanappanA,Hariprasad.K ,Toxic gas and radiation detection monitoring using IoT, International Journal of Engineering Resesarch and Technology, 2017.
- [9] Fabien Charaim, Yusuf BugraErol, Kris Pister. Wireless gas leakage detection and localization Institute Of Electrical And Electronics Engineers, 2016.
- [10] KanZheng, Shaohang Zhao, Zhe Yang, Xiongxiang ,Design and implementation of LPWA-based air quality monitoring system, Institute Of Electrical and Electronics Engineers, 2016.
- [11] NavreentinderKaur, Rita Mahajan, Deepak Bagai, Air quality monitoring system based on Arduino microcontroller , International Journal of Innovative Research in Science, Engineering and Technology, 2016.
- [12] Onengiyem.Georgewill, Ezeofor, Chukwunazo .Design and implementation of SMS based industrial/home gas leakage monitoring and detection alarm system .International Journal of Engineering Trends and Technology, 2016.

# Design of Compact Branch Line Coupler

Vijay Jutru<sup>a,1</sup> and Maheswari S<sup>b</sup>

<sup>a</sup>PG Scholar, Dept of ECE, Panimalar Engineering College, Chennai, India

<sup>b</sup>Professor, Dept of ECE, Panimalar Engineering College, Chennai, India

**Abstract.** The objective is to design a compact branch line coupler to operate at a 2.4GHz frequency. The branch line coupler focuses on -3dB power division with 90° phase difference. T-shaped structure is used to construct the compact branch line coupler. Conventional branch line coupler is also designed and counterfeit using ADS software along with the compact branch line coupler for comparison. The S-parameters for the both coupler are counterfeit and compared. The simulation results of compact branch line coupler had Better return loss, isolation, amplitude and phase difference are all accomplished. Using the proposed method 44% size reduction is achieved. Many microwave applications and integrated circuits, such as amplifier, phase shifters and balanced mixers use branch line couplers.

**Keywords.** Branch line coupler, T-shaped structure, Transmission lines, compact, size reduction.

## 1. Introduction

Directional coupler is a waveguide junction with four ports. It is made up of two waveguides: primary waveguide 1-2 and a secondary wave guide 3-4. When all of ports have been terminated in their respective impedances, in ports 1 and 2, powers is transmitted freely without any reflection and there is no power transmission between the ports 1 and 3 or in between ports 2 and 4 since there isn't any coupling between two pairs of ports. The degree of coupling between ports 1 and 4 and ports 2 and 3 is determined by the coupler's structure. Many microwave applications and integrated circuits, such as amplifiers, phase shifters and balanced mixers used branch line coupler. Branch line coupler can be used as either power divider or power combiner or a part in mixer. Coupler size is large at low frequency. So many techniques are there to make coupler in compact size, For example patch with T slot, lumped object, slow wave structure, stubs with open end etc.

---

<sup>1</sup>Vijay Jutru J, PG scholar ,Dept of ECE, Panimalar Engineering College, Chennai, India, E-mail: vjy7070@gmail.com

## 2. Related works

M.Y. Algumaei, et al.,(2018) [1] said Balanced Mixer using Compact BL, frequency rates 3.1–10.6 GHz.Li Chang and Tzyh-Ghuang Ma et al.,(2017) [2] proposed DualBL/Rat-Race Coupler.Kyo-Soon Choi et al., (2014) [3]said compact BLCalong suppression with t-shaped model.Chih-Jung Chen et al .,(2013) [4] proposed a model where coupler wins 29% fractional bandwidth.He-XiuXu et al.,(2012) [5] proposed RL Handed Transmission Line.Myun-JooPark et al.,(2007) [6] proposed BL (stubbed), transforming balun based on BL structure. The operating frequency is0.75 GHz to 1.25 GHz. J.-L. Le et al., (2007) [7] proposed balunwith enhancement of the bandwidth. The operating frequency is1.5 GHz.Compared to the conventional type a circuit of capacity 20% is gained in this model. Hani Ghali et al., (2004) [8] has designed the Miniaturized Fractal Rat-Race, Branch-Line, and Coupled-Line Hybrids.Space-fitting curves have been used to realise a family of miniaturized hybrid.H.R. Ahn et al., (1994) [9] depicted a new technology for mini sized 3 dB terminated by arbitrary types utilizingelements is presented &the operating frequency is 900 MHz.

## 3. Structure Description and Analysis

Branch-line coupler is designed using microstrip structure. Branch-line coupler is a kind of directional coupler. Usually it is 3dB, 4 ports directional couplers having 90°difference between two output ports. Also denoted as quadrature hybrid made of microstrip. In symmetrical four port, First port is named as Input port, second and third port as output ports and fourth port as isolated port.

Table 1. BLC dimensions

Parameter	Zo	Zo/√2
A	1.530	1.128
Width (W)	3.058m	5.235mm
Effective permittivity (εeff)	3.330	3.491
Length (L)	17.12m	16.723
	m	mm

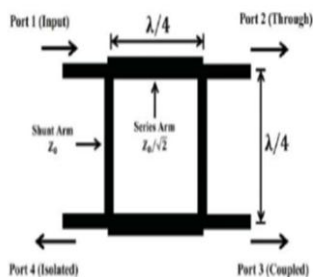


Figure 1. Structure of BLC

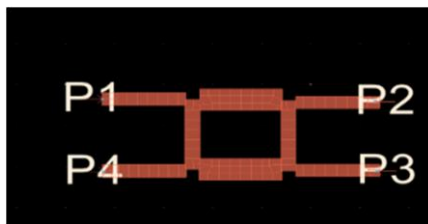


Figure 2. Layout design of Branchline coupler using ADS software

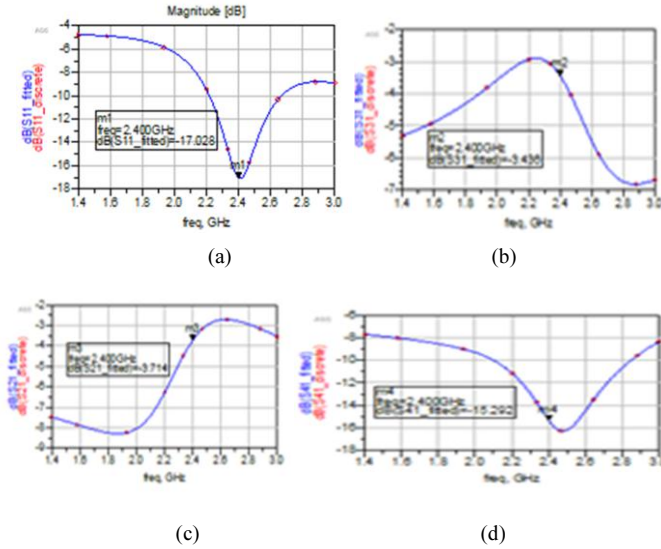


Figure 3(a). Simulation results  $S_{11}$  (b). $S_{21}$  (c). $S_{31}$  (d).  $S_{41}$

The Fig 3(a) depict the simulation result of BLC operating at 2.4 GHz. The S-parameter  $S_{11}$  is obtained as -17dB for operating frequency of 2.4 GHz. Thus above Fig 3(b) & 3(c) shows  $S_{21}$ &  $S_{31}$  which are -3.7 dB and -3.4 dB respectively. Fig 3(d) the shows that the value of  $S_{41}$  is -15.29 dB.

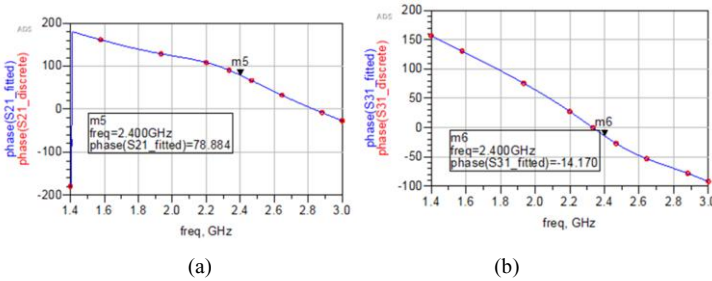


Figure 4(a). Phase of  $S_{21}$  (b).Phase of  $S_{31}$ .

The simulated phase values are shown in Fig 4 (a) and (b). The phase is obtained for  $S_{21}$  is  $78^{\circ}$  and phase is obtained for  $S_{31}$  is  $-14.17^{\circ}$ . Thus the total phase difference is  $92^{\circ}$ .

#### 4. Size Reduction Technique

Branch line coupler architecture is proposed. Size of conventional BLC is reduced using T-shaped model. In this method, ( $\lambda/4$ ) length trans-mission line is implemented using T- shape structure. T-shaped model consists of 2 transmission lines,1 shunt open stub resides middle of 2 series lines.  $\lambda/4$  transmission line is substituted by T-shaped structure.

The equation for  $Z_2$  and  $Z_3$  are

$$Z_2 = Z_1 \cot \theta_2 \quad \dots \dots \dots [1]$$

$$Z_3 = \cos^2 \theta_2 \tan \theta_3 / (1 - 2 \sin^2 \theta_2) \quad \dots \dots \dots [2]$$

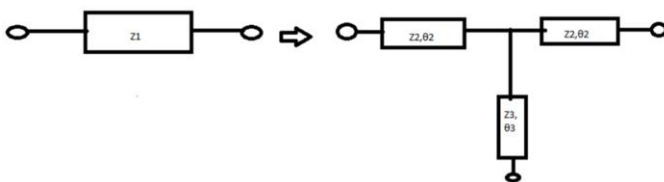


Figure 5.  $\lambda/4$  Transmission line is transformed to T- shaped structure .

Table 2.Dimesions of compact BLC

Parameters	Horizontal section		Vertical section	
	$Z_2=61.22$	$Z_3=30.22$	$Z_2=5.649$	$Z_3=42.75$
A	1.8355	0.986	2.5319	1.331
Width( mm)	2.164	4.770	1.0367	3.929
$E_{eff}$	3.277	3.458	3.08	3.4
Length( mm)	5.823	5.649	5.935	5.649



Figure 6. Layout of compact Branchline coupler using ADS software

### 5. Results And Discussion

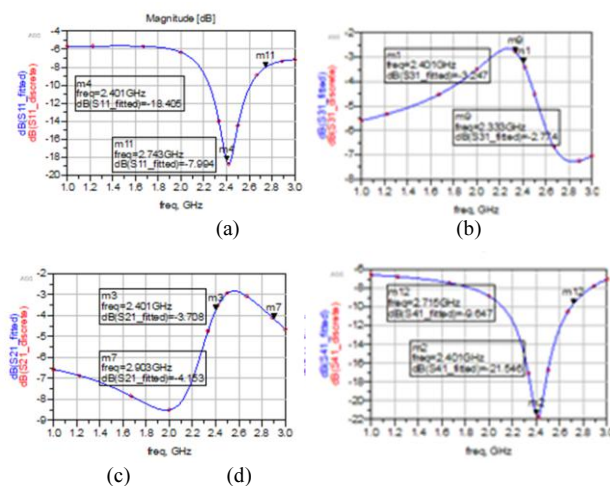


Figure 7.(a) Simulated Results  $S_{11}$  (b).  $S_{21}$  (c).  $S_{31}$  (d).  $S_{41}$

The Fig 7(a) shows the simulation result of compact BLC operating at 2.4 GHz. S-parameter  $S_{11}$  is obtained as -16.87 dB. Thus above Fig 7(b)& 7(c) counterfeit  $S_{21}$  &  $S_{31}$  are -3.9 dB and -3.1 dB respectively. The Fig 7(d) shows  $S_{41}$  is -18.992 dB. The phase got for  $S_{21}$  is  $80.1^{\circ}$  and phase is obtained for  $S_{31}$  is  $-3.9^{\circ}$ . Total phase difference is  $84^{\circ}$ . The size and counterfeit S-parameters of BLC (compact) is compared with BLC (conventional) and depicted in Table 3.

**Table 3.** Comparison of conventional BLC and compact BLC

Parameters	Conventional BLC	Compact BLC
$S_{11}$ (dB)	-17.028	C
$S_{21}$ (dB)	-3.7	-3.9
$S_{31}$ (dB)	-3.4	-3.1
$S_{41}$ (dB)	-15.242	-18.992
Phase difference of $S_{21}$ and $S_{31}$	$92^{\circ}$	$84^{\circ}$
Size of the coupler	$1547.68\text{mm}^2$	$867.6\text{mm}^2$

The size of the designed BLC (compact) is  $867.6\text{ mm}^2$ . The size of the BLC (conventional) is  $1547.68\text{ mm}^2$ . Thus the proposed method achieved the size reduction of 44%.

## 6. Conclusion

A compact BLC is modeled using T-shaped structure operating at 2.4 GHz. The said design shows that overall capacity reduction of 44% is obtained when compared to conventional BLC. The counterfeit S-parameters of compact BLC are weighted with the conventional BLC. Thus the overall response of compact BLC characteristic have two -3 dB outputs with  $90^{\circ}$  of phase.

## Reference

- [1] Algumaei M.Y, Shairi N.A, Zakaria.Z and B. H. Ahmad .A Single Balanced Mixer using Compact Branch Line Balun for Ultra-wideband Applications. IEEE2018.
- [2] LiChang and Tzyh-Ghuang Ma. Dual-Mode Branch-Line/Rat-Race Coupler Using Composite Right/Left-Handed Lines. IEEE Microwave and Wireless Components Letters, Vol. 27, No. 5, May 2017.
- [3] Kyo-Soon Choi, 1 Ki-Cheol Yoon, 2 Jae-Yeong Lee, 3 Choul-Ki Lee, 4 Seong-Cheol Kim, 5 Ki-Byoung Kim, 6 and Jong-Chul Lee, compact branch-line coupler with harmonics suppression using meander t-shaped line, microwave and optical technology letters / vol. 56, no. 6, June 2014.
- [4] Chih-Jung Chen, Analytical Derivation of T-Shaped Structures for Synthesis of Quarter-Wavelength Transmission Lines" IEEE Microwave and Wireless Components Letters, Vol. 23, No. 10, October 2013.
- [5] He-Xiu Xu, Guang-Ming Wang, Xin Chen, and Tian-Peng Li, Broadband Balun Using Fully Artificial Fractal-Shaped Composite Right/Left Handed Transmission Line, IEEE Microwave And Wireless Components Letters, Vol. 22, No. 1, January 2012.
- [6] Myun-Joo Park and Byungje Lee, Stubbed Branch Line Balun, IEEE Microwave And Wireless Components Letters, Vol. 17, No. 3, March 2007.
- [7] J.-L. Li, S.-W. Qu and Q. Xue, Miniaturized branch-line balun with bandwidth enhancement, Electronics Letters 16th August 2007 Vol. 43 No.17.
- [8] Hani Ghali, Tarek A. Moselhy, Miniaturized Fractal Rat-Race, Branch-Line, and Coupled-Line Hybrids, IEEE Transactions on Microwave Theory and Techniques, Vol. 52, No. 11, November 2004.
- [9] H.R. Ahn, I.S. Chang, S.W. Yun, Miniaturized 3-dB ring hybrid terminated by arbitrary impedances, IEEE Trans. Microwave Theory Tech. 42(12) (1994) 2216-2221



# Hand Movement Based Message Transmission and Body Physical Parameters Remote Monitoring Device for Disabled People

D Kalaiyarasi<sup>a,1</sup>, Shruthi.V<sup>b</sup>, VishnuPraba.A<sup>b</sup>, Vanaja.S<sup>b</sup>

<sup>a</sup>Associate Professor, Dept of ECE, Panimalar Engineering College, Chennai, India

<sup>b</sup>UG scholar, Dept of ECE, Panimalar Engineering College, Chennai, India

**Abstract.** The main focus of the proposed model is to manifest a system that is reliable and also effective in terms of communication between Disabled/paralyzed people with the caretaker. When it comes to looking after the disabled or paralytic people who are in large numbers such as in old age homes, Non-Governmental Organizations, and hospitals, it is considerably difficult to monitor the patients based on their needs immediately. To overcome this difficulty a simple yet effective module is developed to establish the communication between the patient (Transmitter) and caretaker (receiver) by mounting a device on the hand of the patient so that by simple movements made using the hand a specific message is communicated to the device which is in a form of a board consisting of the LCD screen and voice module to indicate the message and the board is held by the caretaker separately. The transmission mode is wireless and the range is about 10 meters. The physical parameters of the patient's body are measured and monitored remotely. When there is any abnormal pattern in the parameters such as pulse rate and temperature it is indicated to the caretaker immediately.

**Keywords.** Arduino, Accelerometer, ZigBee, Pulse Rate sensor, temperature sensor.

## 1. Introduction

Embedded systems have extended their application in almost every aspect according to human needs. One such important application of Embedded systems is in healthcare. There are many kinds of research going on to date in healthcare monitoring to provide effective outcomes in terms of health monitoring.

---

<sup>1</sup>Kalaiyarasi. D, Associate professor, Dept. of ECE, Panimalar Engineering College, Chennai; E-mail: id:kalaiccarthi@gmail.com

Using the advancements made in the embedded systems the doctors can monitor the patient's health remotely using telecommunication and evaluate the effectiveness using the embedded trials. The module which we have designed and developed helps the spastic people to make their message conveyed effortlessly without much difficulty. The job of caretaker also becomes easy. The hand movement-based message transmission and body physical parameters remote indication device for spastic people helps both the patient as well as the caretaker equally. When the patient is in danger the pulse rate and the temperature is abnormal. This abnormality is detected and the message is conveyed to the caretaker immediately. Accelerometer plays a major role in determining the tilt direction based on X, Y, and Z directions and the angle of tilt made using the hand. And based on the tilt direction the specific message is conveyed.

The transmitting device consists of a ZigBee module, it is used because of its low-cost implementation, low power consumption and it is more effective because of its long battery life. The message is shown on the LCD screen and the message is also conveyed through the voice module which consists of a DFP layer mini mp3 player. With the help of the voice message the person who cannot read the message can easily be able to hear the message conveyed by the patient. The main goal of the proposed module is to replace the conventional method of communication between the patient and caretaker with modern technologies that are much faster and reliable.

## **2. Literature review**

Mahaveer Penna, et. al [1] conferred the message transmission through motion recognition with the help of an accelerometer measuring the static acceleration of gravity in the tilt sensing requirements and dynamic acceleration causes due to motion, Vibration, and shock. Rafiqul Zaman Khan and Noor Adnan Ibraheem [2] discussed the hand gesture recognition process and how effectively it interacts with the machine. And also discussed the difficulties of hand gesture recognition systems. Ekta Pandey, et.al [3] discussed the motion-based message conveyor for disabled people using an Arduino UNO controller with the temperature sensor and the algorithm for the sensing and transmission of message Via ZigBee. Xiaolei Zhong, Ru Yao, Chun Chen, and Yuanjing Zhu [4] discussed how the transmission capacity of ZigBee can be improved and has provided the solution for the improvement of the transmission range. One of the methods used to enhance the transmission capacity is by using the sensor nodes in a wireless medium. Weimeng Niu, et.al[5] conferred that MEMS are termed as microelectromechanical systems, utilizing the innovation known as small-scale fabrication technology. It has gaps, pit, channels, cantilevers, films and further more mirrors mechanical parts. The MEMS depends on silicon. Yusuf Abdullahi Badanasi [6] discussed the hardware components and the software used to program the Arduino board with a clear explanation on how to write and construct the required module. Rohini Bhilare, et.al [7]-[10] discussed the Motion-Based Message Conveyor for Patients Using the Arduino System and ZigBee. Monitoring the physical parameters of the patient when the parameter values are above or below the threshold levels.

The proposed model is developed for wireless communication between the patient and the nurse using ZigBee and has embedded various sensors such as an accelerometer which is used to measure the tilt direction, pulse rate sensor, temperature sensor to monitor the parameters. When it becomes low or high compared to the threshold level the voice-based and text-based indication is transmitted to the caretaker

immediately. The range of ZigBee transmission is also increased using the wireless sensor nodes.

### 3. Methodology

The proposed model consists of two modules, the transmitter (TX) module, and the receiver (RX) module. The transmitter module is placed on the patient’s movable part for example on the hand. The receiver module is kept with the caretaker. The transmitter module consists of the accelerometer ADXL335, Temperature sensor, and Pulse Rate sensor MAX30100, Arduino microcontroller unit, ZigBee/RF module. The Receiver module consists of an RF module, a Microcontroller, a16x2 LCD Display, a Voice module, Speaker. The accelerometer in the transmitter module works by measuring the static acceleration due to gravity and based on the static acceleration the angle at which the device is rotated concerning the earth is determined. Whenever a patient needs any help he conveys his need by just tilting the accelerometer in different directions. This acts as an input to the accelerometer while the output of it is in volts that are connected to the controller board which acts as the processing unit. In addition to this, a temperature sensor and a pulse rate sensor are placed at the transmitter module to monitor the temperature and the pulse rate in a particular interval of time. The block diagram representation of the transmitter module is shown in Figure1. The second module of the proposed model is the receiver module which is connected with the transmitted module through the Wireless ZigBee/RF module. The Receiver device consists of the RF module, microcontroller, 16x2 LCDscreen, and the voice module along with the speaker. Once the tilt direction is measured by the accelerometer, the specific message is transmitted to the receiver after the processing performed by the Arduino. The message is displayed on the LCD screen and a voice message is also produced at the receiver side using the voice module. The physical parameters of the body such as temperature and pulse rate are monitored at regular interval of time when there is any abnormality i.e. when the value of the measure is below the threshold value the immediate message with the value of the parameters is displayed on the LCD screen and the voice-based message is also sent. The block diagram of the receiver module is represented in Figure 2.

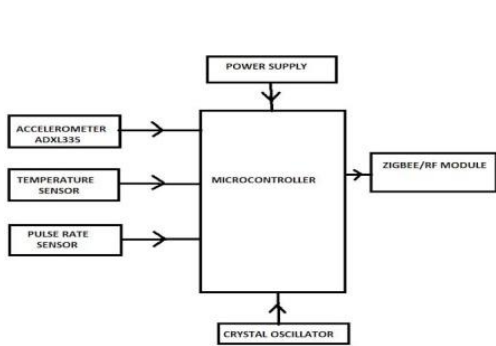


Figure 1. Block diagram of transmitter module

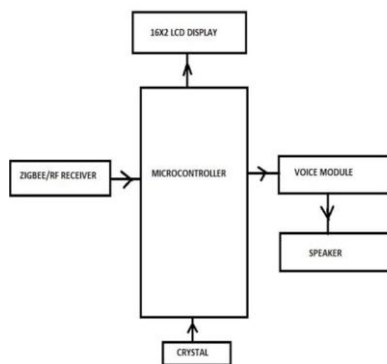
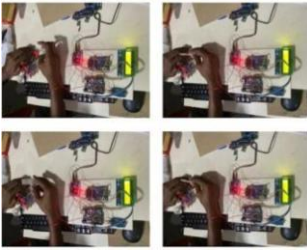


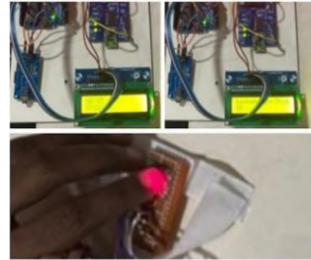
Figure 2. Block Diagram of the Receiver Module

#### 4. Result

As discussed in the methodology of the proposed model when the tilt direction is sensed using the accelerometer Concerning the earth and the data from the accelerometer is sent to the Arduino microcontroller for further processing and based on the tilt direction the specific message is transmitted to the receiver module using ZigBee and the physical parameters such as temperature and pulse rate is monitored remotely in regular intervals of time. When the value of the parameter goes below the threshold level then the message is sent to the caretaker that the patient is in an emergency. If the patient needs to communicate his needs immediately with the caretaker he just tilts his hand in that particular direction so that the message is conveyed both as text and voice to the caretaker. The proposed model setup of transmitter and receiver modules with the output delivered during the hand tilt to convey the message is shown in Figure3 and the temperature and pulse rate monitoring module is shown in Figure4.



**Figure 3.** Different Messages conveyed for different tilt angles



**Figure 4.** Pulse Rate and temperature monitoring module

#### 5. Future scope

The range of transmission could be increased further and the number of physical parameters that are monitored is increased such as in addition to the temperature and pulse rate monitoring, the sugar level monitoring and oxygen level monitoring could be included and using the GSM module if the patient needs medical emergency the message along with the location of the patient is sent to the ambulance service center so that the ambulance can track the location easily and life of the patient can be saved.

#### 6. Conclusion

The proposed module provides complete relief for the patients who are suffering from a disability of performing full-body movements in terms of easy communication with the caretaker to convey their needs immediately without much difficulty and if the patient's pulse rate and the temperature drops below the threshold level then the immediate message is sent to the caretaker so that the required measures can be taken. As the message is sent in both text and voice the caretaker who cannot read can easily understand.

## Reference

- [1] MahaveerPennaet.al, hand gesture controlled message conveyer and controlling devices for physically disabled, 2018 3<sup>rd</sup> IEEE International Conference on Recent Trends in Electronics, Information & Communication Technology(RTEICT-2018) ,MAY18th & 19<sup>th</sup> 2018.
- [2] Rafiqul Zaman Khan and Noor AdnanIbraheem, hand gesture recognition: a literature review, International Journal of Artificial Intelligence & Applications(IJAIA),Vol.3,No.4,July2012.
- [3] EktaPandeyet.al.motion-based message conveyor for disabled patients.International Journal of Engineering Applied Sciences and Technology. 2020Vol.4, Issue12,ISSNNo.2455-2143,Pages240-244.
- [4] Xiaolei Zhong, RuYao, Chun Chenand YuanjingZhu.Research on Scalable ZigBee Wireless Sensor Network Expansion Solution. IOP Conf.Series: Materials Science and Engineering 394 (2018) 032071 doi:10.1088/1757-899X/394/3/032071.
- [5] WeimengNiuet.al. Sum m ary of Research Status and Application of MEMS Accelerometers. Journal of Computer and Communications, 2018, 6,215-221, ISSNOnline: 2327-5227.
- [6] Yusuf Abdullahi Badanasi, <https://doi.org/10.1109/ICECCO.2014.6997578>, 11<sup>th</sup> international conference on electronics, computer , and computation(ICECCO).
- [7] RohiniBhilare, et.al, Motion Based Message Conveyor for Patient Using Arduino System and ZigBee, Volume5 Issue IV, April2017ICValue:45.98ISSN:2321-9653 International Journal for Research in Applied Science & engineering technology.
- [8] Leo Louis, Working principle of Arduino and using it as a tool for study and research, International Journal of Control, Automation, Communication and Systems(IJCACS),Vol.1,No.2,April2016.
- [9] SumitTapkiret.al, Motion Based Message Conveyor for Physically Disabled People, International Research Journal of Engineering and Technology (IRJET)e-ISSN:2395-0056Volume:05Issue:03|Mar-2018.
- [10] Krushnapatiet.al, Motion Based Message Conveyor for Paralytic/Disabled Patient, ISSN:2455-2631©April2018IJS DR|Volume3,Issue4

# Improvement of Multipath Channel Performance for Optical MIMO-OFDM in LED Modulation with Fully Generalized Spatial-Frequency

Nandhini Devi R<sup>a,1</sup>, Leones Sherwin Vimalraj<sup>b</sup> and Lydia J<sup>c</sup>

<sup>a</sup>PG Scholar, Dept of ECE, Panimalar Engineering College Chennai, India

<sup>b</sup>Professor, Dept of ECE, Panimalar Engineering College, Chennai, India

<sup>c</sup>Assistant Professor, Dept of ECE, Easwari Engineering College, Chennai, India

**Abstract.** This paper suggests a scheme to generalize the idea of LED index modulation concept by using the spatial multiplexing principle to relay complex OFDM signals through various channels such as AWGN, Rayleigh and Rician by splitting these signals into their real-imaginary and positive-negative components. In order to combat ISI as well as to increase the channel capacity. The MIMO-OFDM efficiency analysis, taking into account the constraint of the forward current of the LED is extracted. The accuracy of the theoretical results is verified by comparing the Bit Error Ratio (BER) reduction and improvement to the (SNR) results under varying condition of the channel. Using MIMO-OFDM as next-generation techniques, along with QAM aims to provide development of new concepts that will lead to the growth of future optical communication. Simulation results validate data rates gained over optical communication using LED modulation scheme and the pure transmission diversity method.

**Keywords.** OWC, VLC, LED modulation, MIMO-OFDM, FGIS.

## 1. Introduction

The LED Visible Light Communication (VLC) has recently been a big contender for future wireless communication. As a convincing wireless networking technology proposed to address the deficiencies of RF multimedia applications successfully, outside conventional radio frequency (RF) networking, VLC provides many benefits, such as high quality, no requirement for a licence, sensitivity to electromagnetic interference, basic device efficiency and high safety. Due to a mixture of lighting and networking, a substantial number of empirical studies have concentrated on high-speed indoor transmitting in VLC technologies. Similarly, the restricted transmitting throughput of commercial LEDs restricts the transmitted data rate, where signals modulated at different speeds are severely attenuated due to the spatial properties of LEDs.

---

<sup>1</sup>Nandhini Devi R, PG Scholar, Dept of ECE, Panimalar Engineering College, Chennai, India. Email:nandhiniidevir20@gmail.com<sup>1</sup>

## 2. Related Works

The OFDM definition provides the best data rate coverage where the pace is found to be drop [1]. The MIMO idea has increased frequency, but the data coverage has been found to be low [2]. The MIMO-OFDM concept helps to improve both achievable rate and BER upto 6.25 by saving GLIM[4]. LCF and LFF systems have greater sum-throughput while transmitting less feedback compared to the realistic one-bit feedback process[5]. MIMO in VLC, MIMO-SSD which has a normal frequency of 5 MHz and a standard data rate of 100Mbps except 300Mbps in the OFDM[6]. LiFi, F-GSM, F-QSM concepts have 5MHz with low data rate below 100[7]. LED selection are applicable to decorrelate channels for performance enhancement. The collection of MAP and LEDs leads to major efficiency gains and has been shown to achieve a high data rate with reduced speed [8]. It is then concluded that the idea of the MIMO-OFDM is the optimal concept[3]. FGIS system is the resonant frequency used when the data rate is considered to be unstable at enhanced speed[9]. This was discovered to be the most powerful network, with an uniform intensity, power output, and strength [10].

## 3. Proposed System

The proposed scheme generalises the (OFDM) and (MIMO) approaches which have been found especially Enticing in reaching a high throughput, these can even be blended together in the optical transmission system. By OFDM modulation, the signal is analyzed in different frequency-flat channels and (ISI) can be omitted, whereas the MIMO scheme increases spectral efficiency and enhances stability based on the basic concept of communicating streaming data concurrently to several LEDs. Even then, the similarity of the different MIMO channels is a major limitation of MIMO efficiency. The conventional MIMO Rayleigh fading channel system, which connects specific data streams concurrently to multiple LEDs, has been shown to be only useful with a limited channel correlation. In this way, we will take control of all MIMO schemes. In Figure 1 the switching MIMO method is developed for the specified MIMO OFDM system, where modulation instructions are stable for all OFDM sub-channels. The transmission diversity method must use a greater signal constellation size to accommodate a large bandwidth, resulting in a weaker bit error rate (BER) output.

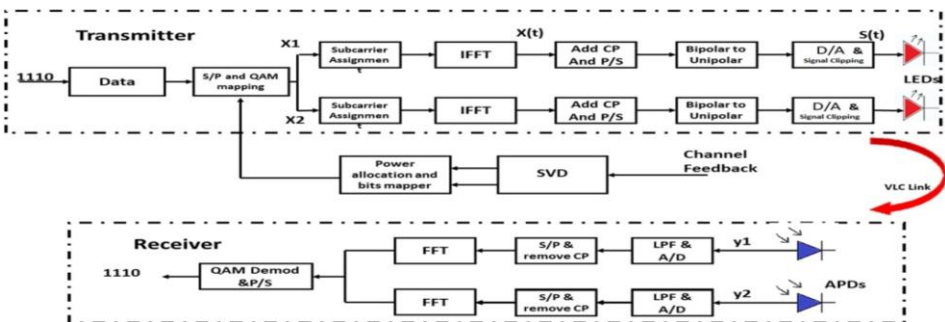


Figure 1. Block Diagram of Proposed System

### 3.1. LMMSE Algorithm

In Optical Wireless Systems using Spatial OFDM, The pilot will then be given to all sub-carriers with only a fixed amount of time. Because the channel is stable throughout the block, the channel is indifferent to bandwidth sensitivity. Because pilots have been sent to both airlines, there is no quantization mistake. The approximation could be made by using LMMSE.

$$\begin{aligned}
 h_{LMMSE} &= X^{-1}y \\
 \text{where } X &= \text{diag} \{x_0, x_1, \dots, x_{N-1}\} \\
 y &= \begin{bmatrix} y_0 \\ \vdots \\ y_{N-1} \end{bmatrix}
 \end{aligned}
 \longrightarrow (1)$$

Here xi seems to be the pilot value transmitted by the ith subcarrier and yi is the value obtained by the ith subcarrier. When the time domain channel vector g is Gaussian and not associated with the noise power, the spatial frequency LMMSE approximation of g is given.

$$\begin{aligned}
 h_{LMMSE} &= FR_g R_y^{-1}y \quad \text{where} \\
 F &= \begin{bmatrix} w_N^{00} & \dots & w_N^{0(N-1)} \\ w_N^{(N-1)0} & \dots & w_N^{(N-1)(N-1)} \end{bmatrix} \text{ and} \\
 w_N^{nk} &= \frac{1}{N} e^{-j2\pi \frac{nk}{N}}
 \end{aligned}
 \longrightarrow (2)$$

From which the Rgy is cross-covariance matrix between g and y and Ryy is the auto-covariance matrix of y. If the channel fades slowly, the channel prediction inside the block can be modified by using decision-return equaliser at each subcarrier. The decision feedback equaliser for the kth subcarrier can be defined as follows: The signal reaction of the kth subcarrier calculated either from formulated {He(k)} is being used to locate the approximate transmit signal {Xe(k)}.

$$X_e(k) = \frac{Y(k)}{H_e(k)} \quad k = 0, 1, \dots, N - 1
 \longrightarrow (3)$$

Xe(k)}is encoded to binary data by "signal demapper" and then recovered by "signal mapper" as Xpure(k)}. The approximate channel {He(k)} is modified as follows:

$$H_e(k) = \frac{Y(k)}{X_{pure}(k)} \quad k = 0, \dots, N - 1 \quad (4)
 \longrightarrow$$

Figure 2 represents the working diagram of the LMMSE algorithm While channel fading is quicker, there is a balance between the error of calculation due to thresholding and the error due to the lack of channel monitoring. OWC has many attractive features, including reduced cost, poor throughput, non - licensed power consumption and versatility.



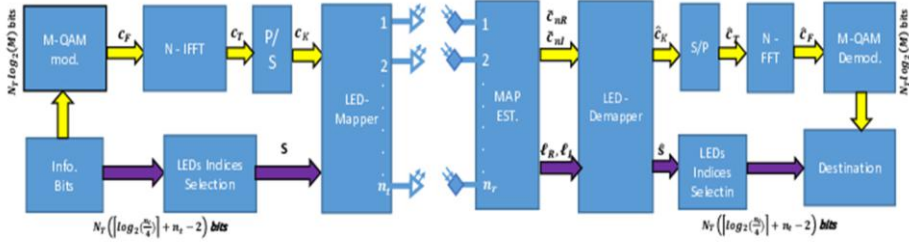


Figure 2. Working model of LMMSE Algorithm

OWC has many useful applications, such as high efficiency, highly secure, non - licensed capacity and usability. The sequences in LMMSE Algorithm are Input data, Convolutional encoding process, QAM Modulation, IFFT data subcarrier signal generation, Cyclic extended data, OFDM signal through channel, BER for LED Modulation.

4. Result and Discussion

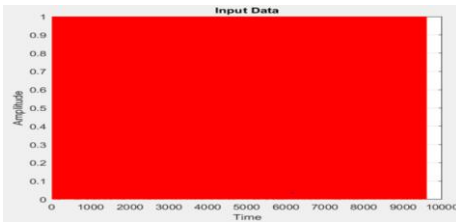


Figure 3. Input Data

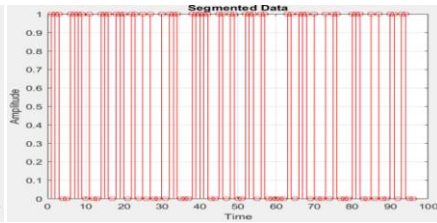


Figure 4. Segmented Data

In figure 3, the input data with baudrate 9600 bits which is also expressed as 9.6Khz for serial communication and the information bits are shown as amplitude with respect to time. Figure 4 represents the generated data converted into symbols by allotting 96 bits for each symbols. Therefore 9600bits are converted into 100 symbols thus segmenting the data.

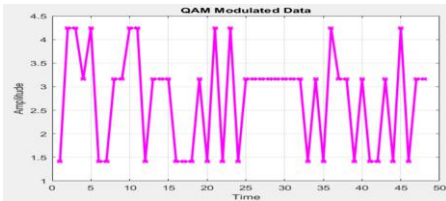


Figure 5. QAM modulated data

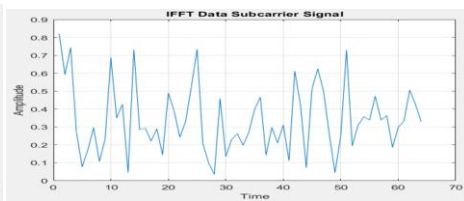


Figure 6. IFFT Data subcarrier signal

The binary data is encoded using convolutional encoder and is shown in Figure 5. The 96bits representing each symbol is converted to 192 bits and then sent to matrix interleaver as the QAM modulator will accepts only the matrix data and not the sequence data. Figure 6 represents the pilots data is placed at the beginning and also inserted after every 13 bits.

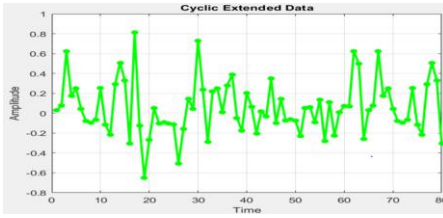


Figure 7. Cyclic Extended Data

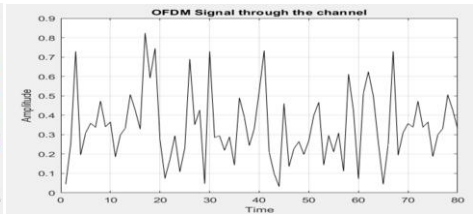


Figure 8. OFDM signal through the channel

The cyclic extension is performed by applying cyclic prefix and it is obtained as shown in Figure 7. Here the last 16 bits are taken and placed in the first 16 bits location and from the 17<sup>th</sup> bit onwards the IFFT data. To transmit the data after cyclic extension in OFDM scheme, channelization is performed where AWGN is introduced into the data at the channel. The OFDM segmented data through the channel is shown in Figure 8.

## 5. Conclusion

This work involves multipath channel performance improvement of optical MIMO-OFDM with fully generalized spatial-frequency LED modulation. This is performed to study the spectral efficiency of OFDM transmit in 3 different channels by changing and improving parameter. The LMMSE equalization and synchronization in VLC network helps to increase handover efficiency, throughput, and channel gain. The characteristics of optical wireless communication at different band width can be measured and the advantage of incredibly wide band width are explored which can be used to increase throughput and channel gain in other multipath scheduling algorithm as future scope.

## References

- [1] Anil Yesilkaya, RuiBianImanTavakkolinia, Harald Haas. OFDM- Based Optical Spatial Modulation. *IEEE Signal Processing*, vol.13, no.6, pp.1433-1444, 2019.
- [2] Hamed G. Olanrewaju, John Thompson. Pairwise coding for MIM-OFDM Visible Light Communication. *IEEE Transaction on wireless communication*, vol 19, no.2, pp. 1210-1220, 2020.
- [3] Hany S. Hussein and Mohammed Hagag. Optical MIMO-OFDM with fully Generalized Index - Spatial LED Modulation. *IEEE Communication*, vol.23, no.9, pp. 1556-1559, 2019.
- [4] Hany S. Hussein. Optical-Polar based MIMO-OFDM with fully generalized index-spatial LED modulation. *IET Communication*, vol. 14 issue.2, pp.282-289, 2019.
- [5] Majid Safari. Bidirectional User Throughput Maximization Based on Feedback Reduction in LiFi Networks. *IEEE Transaction on Communication*, vol. 66, no. 7, pp. 3172-3186, 2018.
- [6] Saud altunibat, RaedMesleh .Enhancing spatial Modulation System Performance Through Signal Space diversity. *IEEE Communication*, vol. 22, no.6, pp. 1136-1139, 2018.
- [7] Hany S, Hussein, Mohammed Hamada and EhabMahammed. Spectral Efficient Spatial Modulation Technique. *IEEE Access*, vol 7, pp. 1454-1496, 2018.
- [8] Manh Le Tran. LED Selection and MAP Detection for Generalized LED Index Modulation. *IEEE Photonic Technology*, vol. 30, no. 19, pp. 1695-1698, 2018.
- [9] Omer Narmanlioglu. Effects of wiring and cabling topologies on the performance of distributed MIMO OFDM VLC system. *IEEE Access* vol 7, no 6, pp 52743-52754, 2019.
- [10] Nandhini devi, Leones Sherwin vimalraj .Optical Wireless Communication: A Survey of Recent Advances, Application and challenges, COMET-International conference on Emerging Current Trends in Computing and Expects technology, pp 790-794,2020.

# Radio Resource Allocation and Mobility Assessment of 5G Wireless Network Using Adaptive Q-LEACH Routing Protocol

Premi.A<sup>a,1</sup> and Rajakumar.S<sup>b</sup>

<sup>a</sup>PG Scholar, Dept of ECE, Panimalar Engineering College, Chennai, India

<sup>b</sup>Professor, Dept of ECE, Panimalar Engineering College, Chennai, India

**Abstract.** The implementation and operation of a Fifth Generation (5G) network aims to achieve a maximum speed, low potential, improved flexibility, and a change in requirements and technologies from service-oriented to user-oriented. The users need resource allocation and management that is effective. Established networks' closed infrastructure and ossified services result in particularly in wireless networks, inefficient resource allocation and underutilized network resources. On the basis the standard of a service provider's utility benefit then customer gratification, various allocation strategies are suggested. Wireless system based 5G another research area aimed at supply distribution and 5G access links is network. In this project, radio resource allocation and mobility assessment of 5G wireless network LEACH routing protocol is implemented. In terms of wireless networks, various architectural integrations of other wireless technologies such as 5G, LTE, Wi-MAX, and so on are highlighted. Furthermore, the project focuses on resource allocation approaches and strategies for cellular networks, as well as comprehensive criteria for future 5G networks

**Keywords.** High Throughput, LEACH Protocol, Wireless Network, Allocation Techniques.

## 1. Introduction

IP networking is sprouting in current wireless technology to offer a quicker Link to the internet, multimedia software, and a plethora on-demand provision of resources to end users. The launch the 5G network has resulted in a 1000-fold increase in data rate demand. Currently, 4G provides optimized output for IP-based networks up to 1Gbps. However, there are billions of connected devices on the market today and increasing demand and variety, and a large a large amount of data, a short latency, and a high throughput are needed. The 5G technology of the future is expected to fulfill these needs, and it is pushing new high-definition networking requests and skills in a variety of areas, including the Internet of Things (IoT). The 5G wireless network is user-centric, necessitating efficient resource distribution to meet Quality of Service requirements (QoS). However, with the growing demand for the 5G wireless network, effective resource distribution is a major challenge.

---

<sup>1</sup>Premi.A, PG Scholar, Dept of ECE, Panimalar Engineering College, Chennai, India, E-mail:jackantopremi@gmail.com.

The 5G network focuses on spectrum sharing in a network with a lot of diversity and a lot of transmission speeds systems (MIMO).

## 2. Related Works

Marina Dupcinov et.al [1] has for AODV The Improved Neighbor Detection Algorithm Routing Protocol was proposed and here the observed problem is has an effect on the AODV routing protocol's algorithm is decline the Ad hoc network efficiency is affected. Effectively improves data throughput using signal to noise ratio (SNR) value. Tuba Firdaus et.al [2] presented the aim of passive optical network (PON) technology is to provide end-users with a low-cost, interference-free, and bandwidth-abundant access system. The observed problem is based on mobility characteristic of node present in MANET. AlyM.El-Semary et.al [3] has designed BP-AODV: Chaotic Map-based AODV Routing Protocol with Blackhole Security for MANETs. It cannot resist the cooperative black-hole Two nodes are targeted. AODV and SAODV are not participating together. Rahim Khan et.al [4] presents concerns related to short-range wireless technology for next-generation personal area networks in terms of standardization, regulation, and growth (PAN). Ultra-wideband (UWB) and 60 GHz millimeter-wave networking technologies offer unrivalled short-range wireless broadband connectivity and are forerunners of multi-gigabit wireless networks.

RobbM.Winter et.al [5] designed Enhanced AODV This Incorrect billing and estimations of power consumption may occur as a result of using this unit. Yang Hui et.al [6] Researched Based on a Wireless Mesh Network and the DSDV Routing Protocol. The protocol can provide better delivery rates and lower network latency, however, there is still a serious problem in the network and cluster header load is too heavy. Manjunath M et.al [7] discussed Spatial DSDV (S-DSDV) reduces the misguiding impact of pheromones on unrelated paths by broadcasting routing tables to immediate neighbours with a lower sequence number.

## 3. Adaptive Q-LEACH

The various types of LEACH protocols are implemented in the proposed system. Out of all LEACH protocols adaptive Q-LEACH is more advanced, the following advantages are gained in the adaptive Q-LEACH protocol. Since the adaptive Q-LEACH network is divided into sub-sectors, the clusters that form within these sub-sectors are more deterministic. Adaptive Q-LEACH is a routing protocol that balances the benefits of both location-based and hierarchical-based routing protocols. The restricted flooding term is used, in which packets are transmitted by nodes closer to the destination or in a promoting environment. Individual nodes measure distance and forwarding zone information to determine their progress toward their destination

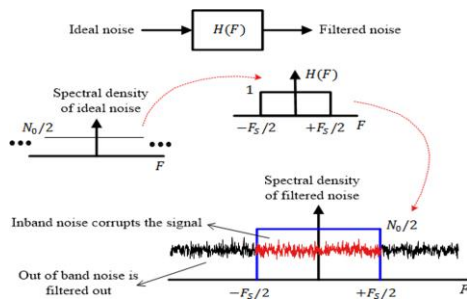


Figure 1.Adaptive Q-LEACH

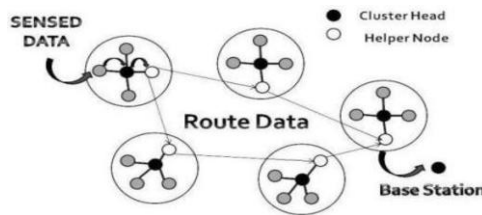


Figure 2.Protocol Model

#### 4. Fading Channel

The differences in channel intensity over time and frequency are a defining feature of the mobile wireless channel. The variations can be roughly divided into two types:

- 1) Signal path loss as a function of distance and shadowing by large objects like buildings and hills cause large-scale fading. This happens when the mobile travels a distance on the order of the cell size, and it is normally frequency agnostic.
- 2) According to the positive and disruptive interference of the various signal paths between the transmitter and receiver, small-scale fading occurs. This happens on the same spatial scale as the fading forms discussed in this chapter, but with a stronger focus on the latter. Fading on a wide scale is more applicable to problems like cell-siteplanning.

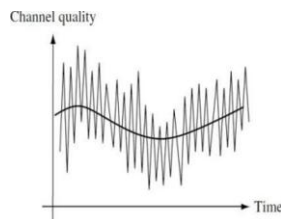


Figure 3. The performance of a channel varies over time

### 5. Result andDiscussion

Thus in adaptive Q LEACH mobile nodes are dynamically connected. Battery power in the network operating time is determined by mobile nodes adaptive Q-LEACH. So, in addition to reliability and delivery time, energy-conscious routing is a critical aspect to consider. There are two types of energy efficient solutions.

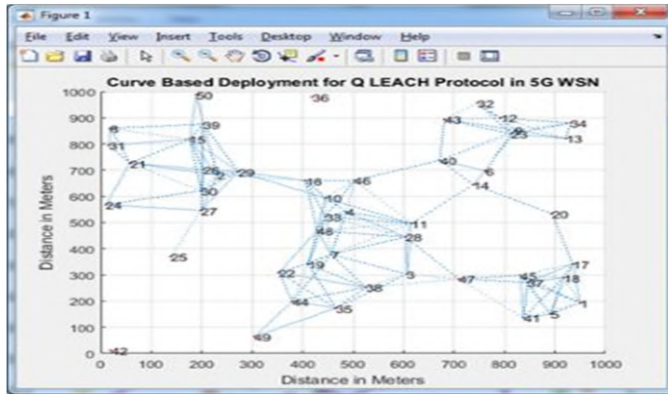


Figure 4.Adaptive Q LEACH protocol clustering

Minimizing the amount of resources needed to send and receive packets. To prevent needless heading, a mobile node's idle time should be kept minimum. The adaptive Q LEACH protocol with clustering of data. The network area covered by the adaptive Q LEACH and residual energy based method. This shows the need of dynamic deployment of the sensor nodes. In both we have deployed the nodes for area 100 x 100 but due to adaptive Q LEACH nodes are within the specified area and all nodes will dies in that area only. But in our proposed method the nodes crossed the give area .that is some nodes are moved above 100. By this we can say that the coverage area is increased.

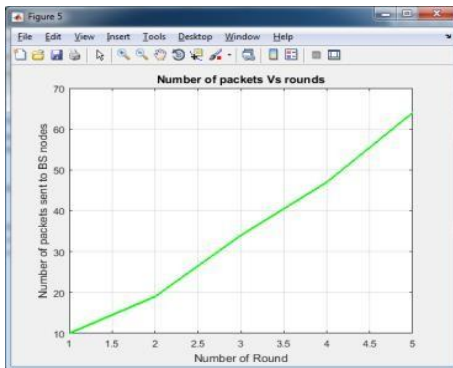


Figure 5.Average energy of eachnodeRound=50

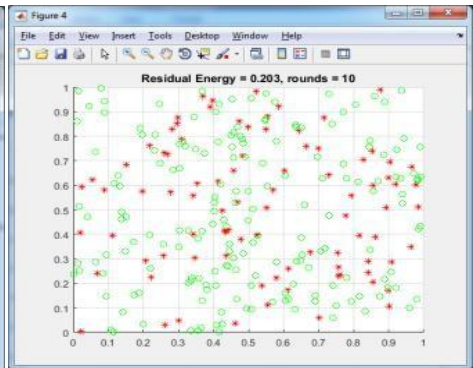


Figure 6. Number of Dead nodesRound=25.

From the graph, we know that there are some nodes that begin to die in about 250s of running time adaptive. When all nodes in the Q LEACH protocol died in adaptive mode, the nodes started to die in the 400s. Q LEACH protocol. Here the failure node is calculated as zero. The round trip time is used to detect it. Since it takes longer to relay the packet which causes it to be dropped. By comparing the round trip delay time of this path to a threshold value, the failure node is defined.

## 6. Conclusion

For wireless data exchange, wireless network modeling and simulation was used in 5G environment using adaptive Q-LEACH protocol. In wireless communication, data mobility is enhanced by increasing the SNR and increasing the system's throughput. The BER parameters are used to prevent the ongoing call from being dropped by holding handoff and the possibility of establishing a new call from being blocked due to a temporary lack of an idle channel. By correctly detecting interference, the 5G wireless network is used to provide safe communication. Calculating different parameters to show the correct implementation of the proposed method enhances QoS.

## References

- [1] Marina Dupcinov. Improved Neighbor Detection Algorithm For AODV Routing Protocol. IEEE Communication Letters, VOL.7, No12, December 2003.
- [2] Tuba Firdausi .Congestion Aware Routing In AODV Based Mobile Ad-Hoc Network (Manet). IEEE J. Sel. Areas Commun s, Vol. 23, No. 2, pp.201-220,2019.
- [3] AlyM.El-Semary, BP-AODV: Blackhole Protected AODV Routing Protocol for MANETs based on Chaotic Map. IEEE Trans. Network Commun., vol. 10, no. 11, pp. 3666–3674, Nov.2011.
- [4] Rahim Khan .Mac-AODV Based Mutual Authentication Scheme For Constraint Oriented Networks. IEEE Journal of Communications and Networks, vol. 8, pp. 44459-44469,2020.
- [5] Yang Hui. Research on DSDV Routing Protocol Based on Wireless Mesh Network. vol. 8 978-1-5386-1243-9/18/\$31.00 c IEEE, The 30th Chinese Control and Decision (2018CCD).
- [6] Manjunath M.Spatial DSDV (S-DSDV) routing algorithm for mobile ad hoc network. Journal on Contemporary Computing and Informatics(IC3I),2014.
- [7] Shuo Wu.An Adaptive on-Demand Multipath Routing Protocol With QoS Support for High-Speed MANET. in proc. IEEE Transactions on VehiculaTechnologie Volume: 8 Journal Article2020.
- [8] Margam K. Suthar .Performance Analysis of AODV and DSR Routing Protocol for Wireless AdhocNetwork .International JournalonElectronicsandElectricalEngineering,vol.5,pp.284,2017.
- [9] Ould-Khaoua.M . Bandwith-Efficient Routing Protocol For Mobile Ad Hoc Networks. In Proc. IEEE Access Volume: 150, Issue:4 Journal Article,2003.

# Low Power, High Speed MUX Based Area Efficient Dadda Multiplier

Kalaiyarasi.D<sup>a,1</sup>, Pritha.N<sup>b</sup>, Srividhya.G<sup>b</sup>, Padmapriya.D<sup>b</sup>

<sup>a</sup>Associate Professor, Dept of ECE, Panimalar Engineering College, Chennai, India

<sup>b</sup>Associate Professor, Dept of ECE, Panimalar Engineering College, Chennai, India

**Abstract.** The multiplier is a fundamental building block in most digital ICs' arithmetic units. The multiplier architecture in modern VLSI circuits must meet the main parameters of low power, high speed, and small area requirements. In this paper, a 4-bit multiplier is constructed using the Dadda algorithm with enhanced Full and Half adder blocks to achieve a smaller size, lower power consumption, and minimum propagation delay. The Dadda Algorithm-designed multiplier is used in the first phase to reduce propagation delay while adding partial products in three stages provided by AND Gates. In the second phase, each stage of the Dadda tree algorithm is built with an enhanced Full and half adders to reduce the design area, propagation delay, and power consumption while still meeting the requirements of the current scenario by using MUX logic. In an average of Conventional array Multipliers, the proposed Dadda multiplier achieved an 84.68 % reduction in delay, 70.89 % reduction in power, 84.68% increase in Maximum Usable Frequency (MUF), and 95.55% reduction in Energy per Samples (EPS).

**Keywords.** 4\*4 multiplier, Dadda algorithm, Enhanced Full and Half adder, MUX logic

## 1. Introduction

The multiplier is used in a variety of applications, including VLSI design, signal processing, digital communication, and electronics. In the current scenario, low power, high speed, and a small area are important. Multipliers with the least delay and power dissipation are chosen in order to achieve optimal throughput and device response when designing an optimal circuit. The Dadda Algorithm multiplier architecture operates at a high frequency and consumes comparatively less power, as well as magically reducing power consumption, which leads to the concept of using it in larger circuits where multipliers play a major role [11-12]. The Dadda Algorithm-designed multiplier is used in the first phase and MUX logic in the second phase, each stage of the Daddatree algorithm is built with an enhanced Full adder and half adder to further reduce the design area, propagation delay, and power dissipation. This paper has seven sections. Multiplier with an existing method is presented in Section II, proposed research is described in Section III, block diagrams and algorithm implementation are

---

<sup>1</sup>Kalaiyarasi.D, Associate Professor, Dept of ECE, Panimalar Engineering College, Chennai, India.  
Email: kalaiccarthi@gmail.com



presented in Section IV and V, simulation and implementation results are listed in Section VI, and the conclusion is in Section VII.

## 2. Previous Research

Many algorithms named Wallace tree [1-2], Vedic and Booth algorithms [3] were used in previous research to achieve optimized power and delay product. To reduce the area and latency, a booth encoding method was used in conjunction with a compressor [4]. Furthermore, to minimize switching operation, partial products [5] are reordered to reduce power consumption. In the reduction power, a modified full adder with 4:1 multiplexers is used, and a full adder with six 2:1 multiplexers is also designed. The digital design with low power dissipation and minimal delay, as well as maximum throughput and high speed can be achieved by various techniques such as merged delay transformation [6], genetic algorithm [7], evolutionary algorithm [8], delay path Unqualization [9], carry-look-ahead logic [10], etc.

## 3. Proposed Research

To achieve less area, low power consumption, and minimal propagation delay, a 4-bit multiplier is constructed using the Dadda algorithm and enhanced Half and Full adder blocks in the proposed work. The multiplier built in the first phase with the Dadda algorithm was used to reduce the propagation delay. By using multiplexer logic, a multiplier built in the second phase uses enhanced Full adder and half adder to further reduce the design area, propagation delay, and power dissipation. Area is saved as a result of the above two steps, and propagation delay is magically reduced.

### 3.1 Introduction to Dadda Tree Algorithm

A  $4 \times 4$  multiplier has 16 partial products, the tree's height is four. The Dadda Algorithm was used to reduce the tree's height from four to two levels. Since the simulation of the next stage does not need to wait for carry from the previous stage, the Dadda Algorithm is ideal for reducing the overall multiplier design delay.

### 3.2 Dadda Algorithm Stages

The aim of the algorithm is to reduce the tree's height from four to two. The height of the tree is reduced from four to three in the first stage and from three to two in the second stage of the Dadda algorithm. By using ripple carry adders in the third stage of the Dadda algorithm, the tree's height is limited to two. To reduce this tree, the first two Dadda stages are used. The Dadda phases are depicted in Figs. 1, 2, and 3.

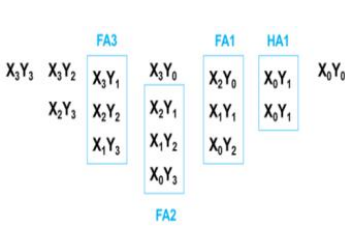


Figure 1. First Stage of Dadda Tree

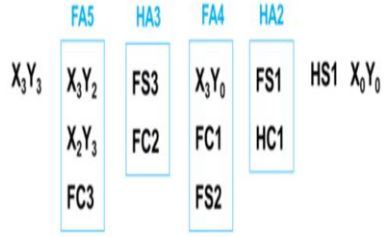


Figure 2. Second Stage of Dadda Tree

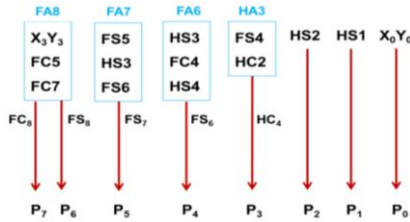


Figure 3. Third Stage of Dadda Tree

3.3. Algorithm Implementation

To minimize the height of the tree from four to three, a half adder is added to the second column, a full adder to the fourth column, and two full adders to the third and fifth columns. To reduce the height of the tree from three to two, two half adders are applied to the third and fifth columns, and two full adders are applied to the fourth and sixth columns in the second level. In the final step, ripple carry adders are used to confine the multiplication results. Parallel processing of half adders and full adders, where each adder works independently and does not wait for carry from the previous level, will increase the efficiency of the implementation.

4. Architecture of Proposed Dadda Multiplier

The block diagram of Proposed Dadda multiplier is shown in Fig. 4.

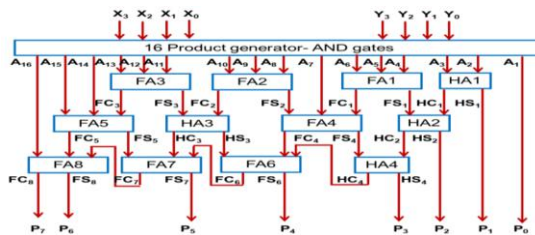


Figure 4. Block Diagram of Proposed Dadda Multiplier

### 5. Building Blocks of Proposed Multiplier

The MUX-based enhanced AND gate, enhanced half adder and enhanced full adder are shown in Fig.5,6 and 7 respectively.

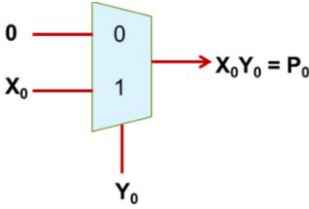


Figure 5. Proposed AND gate using 2:1 MUX

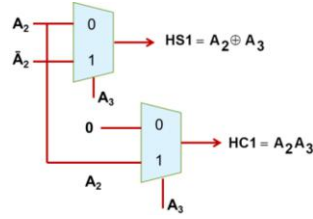


Figure 6. Proposed HA using 2:1 MUX

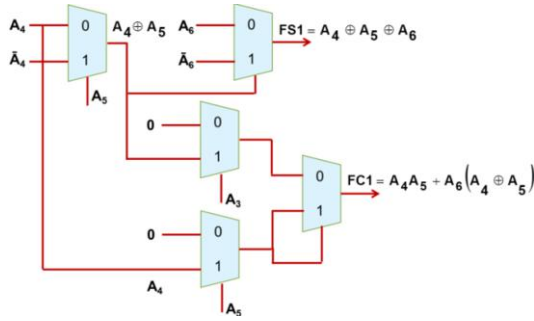


Figure 7. Proposed FA using 2:1 MUX

### 6. Implementation Results

This section describes the implementation results of a four-bit multiplier based on the Dadda algorithm, as well as enhanced full and half adders. Using Altera Quartus II and the EP2S15F484C3 device, a four-bit multiplier design is developed and simulated. Table 1 shows the design, implementation, and analysis of a multiplier using enhanced full adders and half adders, as well as their performance parameters. The RTL view, Chip layout and simulation output of the proposed multiplier are shown in Fig.8, Fig.9 and Fig.10, respectively. The proposed Dadda multiplier with enhanced full adder and half adder achieved 84.68% reduction in delay, 70.89% reduction in power consumption, 84.68% increase in Maximum Usable Frequency (MUF), and 95.55% reduction in Energy per Samples (EPS).

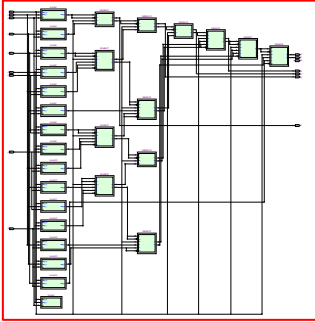


Figure 8.RTL View of Proposed design

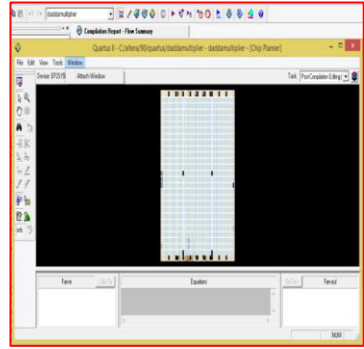


Figure 9.Chip layout of proposed design

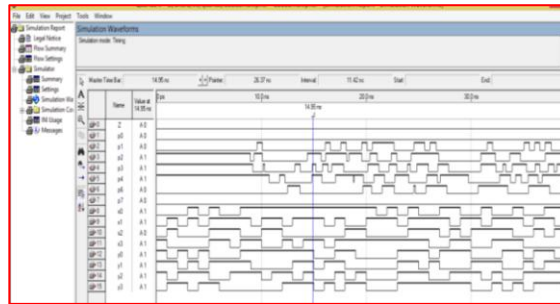


Figure 10.Simulation Output of Proposed Design

Table 1. Performance Comparison

Multiplier Type	Delay(ns)	Power(mW)	MUF (MHz)	PS (ns x mW)
Multiplier using Conventional Full Adder	49.98	2.197	20.00	109.8
Multiplier using 4:1 MUX based Full Adder	49.09	5.592	20.37	274.5
Multiplier using 2:1MUX based Full Adder	49.57	1.218	20.17	60.37
Proposed Dadda Multiplier using 2:1 MUX	7.588	0.6	131.78	4.5528

### 7. Conclusion

The proposed 4 bit multiplier design has been developed, and the schematics have been simulated using Altera Quartus II and the EP2S15F484C3 unit. The schematic for the

Dadda tree algorithm is shown, which includes an AND gate with a 2:1 MUX, a half adder with two 2:1 MUX, and a full adder with four 2:1 MUX. The output parameters are compared to those of current full adder array multipliers. As the proposed design incorporates the Dadda algorithm to minimize propagation delay and the number of stages or area of the multiplier, it is implemented efficiently. Furthermore, by enhancing the full adder and half adder in each stage of the Dadda tree algorithm, in an average of Conventional array Multipliers, the proposed Dadda multiplier achieved an 84.68 % reduction in delay, 70.89 % reduction in power, 84.68% increase in MUF, and 95.55% reduction in EPS.

## References

- [1] Wallace.A suggestion for a fast multiplier. IEEE Transaction on Electronic Computers, Vol. EC-13, pp.14-17.
- [2] ShahzadAsif and Yinan Kong .Low Area Wallace Multiplier,VLSI Design. vol. 2014.
- [3] Rao.M.J , Dubey.S .A high speed and area efficient Booth recoded Wallace tree multiplier for Fast Arithmetic Circuits. in Asia Pacific Conference on Postgraduate Research in Microelectronics and Electronics (PrimeAsia), Hyderabad, India, 5-7 Dec. 2012, pp.220-223.
- [4] Karthick, S. Karthika and S. Valannathy, Design and Analysis of Low Power Compressors, International Journal of Advanced Research in Electrical, Electronics and instrumentation Engineering, YoU, Issue 6, Dec. 2012.
- [5] S.T.Oskuii,P.G.Kjeldsberg,Power optimized partial product reduction interconnect ordering in parallel multipliers, NORCHIP, Aalborg,19-20 Nov.2007,pp.1-6.
- [6] Design of high-speed carry save adder using carry look ahead adder. Available from: [https://www.researchgate.net/publication/301407573\\_Design\\_of\\_high\\_speed\\_carry\\_save\\_adder\\_using\\_carry\\_lookahead\\_adder](https://www.researchgate.net/publication/301407573_Design_of_high_speed_carry_save_adder_using_carry_lookahead_adder) [accessed Sep 22, 2017].
- [7] PremKumar.P, Duraiswamy.K and JoseAnand.A . An optimized devicesizing of analog circuits using genetic algorithm, European Journal of Scientific Research, vol.69, no.3, pp.441-448,2012.
- [8] RevnaAcarVural, Member, IEEE, BurcuErkmen, Member, IEEE, UfukBozkurt, TulayYildirim, Member, IEEE, CMOS Differential Amplifier Area Optimization with Evolutionary Algorithms, Proceedings of the World Congress on Engineering and Computer Science 2013 Vol II WCECS 2013, 23-25 October, 2013, San Francisco, USA.
- [9] Jorge Juan Chico, Enrico Macii, book chapter 17, Power- Consumption Reduction in Asynchronous Circuits Using Delay Path Unequalization, page (151-160), 13th International Workshop, PATMOS 2003 Turin, Italy, September 10-12, 2003, Proceedings.
- [10] RaminderPreet Pal Singh, Parveen Kumar, Balwinder Singh, Performance Analysis of 32 bit Array Multiplier with Carry Save Adder and with Carry Look ahead adder, in International Journal of Recent Trends in Engineering, Vol 2, No. 6, November 2009
- [11] Bharathi.S.L, Pritha.N, Srividhya.G, PadmaPriya.D .A Frame of Multiplier using Compactor. Int .Journal of Innovative Science and Research Technology, ISSN: 2456-2165,Vol. 3 Issue 3, March – 2018.
- [12] Kalaiyarasi.D and Saraswathi.M.Design of an Efficient High Speed Radix-4 Booth Multiplier for both Signed and Unsigned Numbers. International Conference on Advances in Electrical, Electronics, Information, Communication and Bio-Informatics (AEEICB) 27-28 Feb. 2018, IEEE 2018.

# An Extended Mondrian Algorithm – XMondrian to Protect Identity Disclosure

R.Padmaja<sup>a,1</sup> and V. Santhi<sup>b</sup>

<sup>a,b</sup>Professor, School of CSE, VIT University, Vellore - 632014, Tamil Nadu, India

**Abstract.** In recent days, Privacy Preserving Data Publishing (PPDP) is considered as vital research area due to rapid increasing rate of data being published in the Internet day by day. Many Organizations often need to publish their data in internet for research and analysis purpose, but there is no guarantee that those data would be used only for ethical purposes. Hence data anonymization comes into picture and play a vital role in preventing identity disclosure, also it restricts the amount of data that can be seen or used by the external users. It is an extensively used PPDP technique among data encryption, data anonymization and data perturbation methods. Mondrian is considered as one such data anonymization technique that has outperformed compare to many anonymization algorithms, because of its fast and scalable nature. However, the algorithm insists to encode the categorical values into numerical values and decode it, to generalize the data. To overcome this problem, a new extended version of Mondrian algorithm is proposed, and it is called XMondrian algorithm. The proposed algorithm can handle both numerical and categorical attributes without encoding or decoding the categorical values. The effectiveness of the proposed algorithm has been analysed through experimental study and observed that the proposed XMondrian algorithm outshine the existing Mondrian algorithm in terms of anonymization time and Cavg. Cavg is one of the metric used to quantify the utility of data.

**Keywords.** Data Anonymization, Mondrian, Privacy Preserving Data Publishing, X-Mondrian, pseudonymous data, K-anonymity, Identity Disclosure

## 1. Introduction

Many organizations often need to release their data for research and other public analysis purpose. For instance, medical organizations need to publish their patient data in the internet for medical researchers to carry out their research. But the patient data contains personal information of the patients which needs to be preserved before the data gets released in the internet. Initially, organizations were publishing their data by removing the recognizing attributes like Social Security Number, Phone Number, Email Id etc., to protect the identity of individuals [1]. Dataset in which direct identifiers are eliminated and indirect identifiers remain intact are called pseudonymous data. Even then the research has proved that identity of individuals is getting disclosed because of quasi identifiers in the published dataset. Quasi identifiers are set of attributes to identify tuples [2]. A classical situation of conventional privacy preserving data publishing (PPDP) is depicted in the below Fig.1, which demonstrates diverse

---

<sup>1</sup>V.Santhi ,professor ,school of CBSE,VIT university, vellore  
Email:vsanthi@vit.ac.in

phases of data publishing. But this conventional data publishing method will not preserve the individuals privacy as the data is linked to public dataset like voter database, census data etc..., through which the privacy of individuals will be revealed out [3].

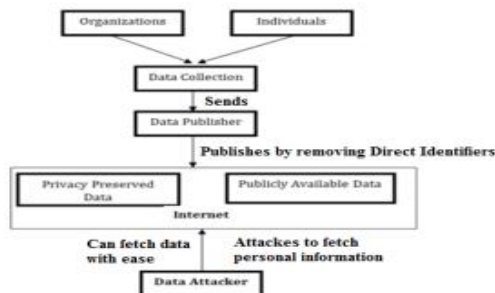


Figure 1. Conventional Model of PPDP for Pseudonymous Data

As a result, privacy preserving data publishing techniques has turned into a critical area of research for analyser’s and specialists. Hence, the objective of privacy preserving techniques is to mask or encrypt or add noise to the original dataset to protect the identity disclosure without compromising the data utility. Thus, the spirit of privacy preserving techniques is to publish datasets without compromising the data usefulness. Manipulating quasi identifiers mathematically and technically guarantees to prevent re-identification is called **Anonymous Data**. This reality made many researchers consider new confronts to preserve the personal or sensitive information of the individuals in the published datasets. A contemporary model of PPDP is depicted in Figure. 2

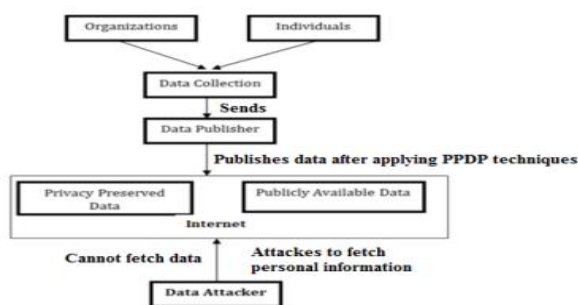


Figure 2. Contemporary Model of PPDP for generating Anonymous Data.

In general, Privacy preserving techniques are categorized into three types 1) Data Encryption 2) Data Anonymization and 3) Data Perturbation. Data anonymization technique, which uses generalization and suppression for anonymization, are the broadly studied and extensively accepted approach for protecting the identity disclosure. In data anonymization, the data is generalized or suppressed so that individual’s

identity is not revealed. As a result, multiple data anonymization algorithms like datafly, incognito, Mondrian, info gainMondrian, LSD Mondrian have being projected in the region of data anonymization technique. The Mondrian algorithm is a widely adopted anonymization algorithm because it reaches low data distortion. As per the literature review carried out, it is clear that Mondrian outperforms the other algorithms in terms of two metrics named DM and  $C_{AVG}$ , which is used to calculate the size and number of equivalence classes created. The Mondrian's equivalence groups have a greater granularity, which helps to improve data usefulness, but it takes time for converting categorical values into numerical values.

In this paper, an improved version of the current Mondrian algorithm is proposed and it is named as, XMondrian algorithm. In Mondrian algorithm, if the dataset contains any categorical values, then the algorithm needs to convert categorical values into numerical values. In order to overcome this impediment, an extension to the Mondrian algorithm called XMondrian algorithm is proposed.

## 2. Methods and Materials

### 2.1 Privacy Risks and Models

In this segment, the most significant risks associated with the disclosure of personal information is has been presented elaborately. The models that can be used to defend against these threats are then addressed.

#### 2.1.1 Privacy Threats

Privacy threats are identified with 3 distinct kinds of identifiers and they are direct attribute, quasi identifies and sensitive attribute. In Figure 3, a model dataset is presented, in which SSN is an identifying identifier, marital status, age and gender are quasi-identifiers, and income is a sensitive attribute [2].

	ID	QIDs			SA
Tuple #	SSN	Marital Status	Age	Gender	Income
1	1234	Separated	38	Female	<=50000
2	2341	Separated	43	Female	>50000
3	2567	Married-civ-spouse	54	Male	>50000
4	1452	Widowed	43	Female	>50000
5	1765	Married-AF-spouse	50	Male	<=50000
6	1356	Never-Married	39	Female	<=50000

Figure 3. Micro Data from Census Dataset

The three classes of privacy threats based on above three types of attributes are **identity disclosure, membership disclosure and attribute disclosure**[5].



### 2.1.2 Privacy Models

The popular privacy models have been discussed with respect to the privacy threats as mentioned in section 2.1. The classification based on privacy models is presented in Figure 4.

Attack Type	Privacy Models
Identity Disclosure	k-Anonymity, K-Map etc..
Membership disclosure	$\delta$ -presence, c-confident $\delta$ -presence etc ..
Attribute disclosure	l-diversity, t-closeness

Figure 4. Privacy models against Privacy Threats[5]

The most established model for protecting identity disclosure is k-anonymity.

### 2.2 Privacy Preserving Operations

Privacy operations to achieve various privacy models are generalization, suppression, anatomization, permutation, perturbation [6]. Among these operations generalization and suppression are data anonymization technique operators. Generalization substitutes the original attribute value into a less specific value, but more general value. Suppression works by replacing some values with a special character like “\*”. Suppression operation is generally used where it is not possible to generalize.

### 2.3 Privacy Preserving Techniques

The techniques to preserve the privacy of individuals are classified into 3 types : The data encryption, data perturbation and data anonymization .Anonymization is a optimal technique to protect Identity Disclosure. The proposed algorithm, XMondrian is one such data anonymization Algorithm [7]. In data anonymization, the user identity is modified to less specific values to protect the sensitive information.

### 2.4 Mondrian, A Data Anonymization Algorithm to prevent Identity Disclosure

Data anonymization is the process of taking the personal data and modifying it in such a way that it can no longer be used to identify an individual. Data anonymization is most extensively used technique to publish privacy preserved Data because of two reasons. 1) it can be applied on any type of data including big data and real time applications data and 2) it is very easy to implement.

Most anonymization algorithms rely on generalization and suppression to turn original datasets into anonymous data sets. The popular algorithms where generalization operations are mostly applied are urgus, Datafly, Median Mondrian, Infogain Mondrian, Incognito etc... Among these Algorithms, Median Mondrian Algorithm outperforms other Algorithms. The privacy model to protect Identity disclosure is K-Anonymity. Every Data Anonymization Algorithm that tries to protect identity disclosure should satisfy the k-anonymity principle.

### 2.4.1 k-anonymity

Sweeney and Samarati has introduced the k-anonymity principle [5]. This privacy principle demands that each tuple in a discharged table cannot be connected to a probability greater than  $1/k$ , meaning that each tuple is indistinguishable from at least  $k - 1$  other tuples. A dataset is called to be k anonymous dataset if each equivalence class have atleast  $k-1$  records with respect to quasi identifiers[8]. Therefore for every dataset T, k-anonymization is performed to produce a new dataset T\* that verifies the k-anonymity property on the set of quasi-identifiers. In K-anonymous table, the probability of discovering an individual from set of k tuples will be  $1/k$  which is the degree of uncertainty[3].

### 2.4.2 Mondrian Algorithm

Mondrian is a k-anonymity data anonymization algorithm that recursively partitioning the dataset by finding the median of the quasi identifier that has largest number of unique values[9]. This algorithm partitions recursively until the equivalence class size is less than  $2k-1$ .

---

Algorithm: *Mondrian*[14]

---

```

Input: Quasi identifiers qid and a Dataset D.
Output: An Anonymized Dataset D*
Anonymize (partition)
if (no allowable multidimensional cut for partition)
return qid, partition → summary
else
dim ← choose-dimension ()
fs ← frequency-set (partition, dim)
splitAttribute ← largestWideRange(fs)
splitVal ← find-median(splitAttribute)
lhs ← {t ∈ partition: t.dim ≤ splitVal}
rhs ← {t ∈ partition: t.dim > splitVal}
return Anonymizer(rhs) U anonymizer(lhs)

```

---

Figure 5. Mondrian Algorithm

## 3. Extended Mondrian Algorithm (XMondrian)

Even though the existing Mondrian algorithm is the widely used algorithm to protect identity disclosure but the algorithm can be applied only on dataset that contains numerical attributes. If a dataset contains categorical attributes, then the algorithm needs to convert the categorical attribute values into numerical values in order to apply the Mondrian algorithm. Again the corresponding numerical values of the categorical attribute need to convert into categorical values. This process of encoding and decoding takes anonymization time. To overcome this limitation, we extend the Mondrian algorithm as XMondrian algorithm which can handle both numerical and categorical attribute without encoding and decoding.

XMondrian algorithm recursively partitions the dataset into equivalence classes based on quasi identifier that has largest normalized range called splitattribute. Once split attribute is identified, split Value need to be identified. If the splitAttribute is categorical, for each distinct value of the attribute, a partition is created and if the split attribute is numerical, the partition depends on the median of the split attribute. The

process continues until the size of the partition is less than  $2k-1$ . Thus, XMondrian produces smaller size equivalence classes when compared to Mondrian, which indicates less information loss and less anonymization time.

---

Algorithm: *Xmondrian*

---

```

Anonymize(partition)
if (no allowable multidimensional cut for partition)
    return  $\mathcal{Q}_{\dots}$  partition  $\rightarrow$  summary
else
    dim  $\leftarrow$  choose-dimension ()
    fs  $\leftarrow$  frequency-set (partition, dim)
    SplitAttribute  $\leftarrow$  largestWideRange(fs)
    if splitAttribute is Numerical
        splitVal  $\leftarrow$  find-median(splitAttribute)
        lhs  $\leftarrow$  {t  $\in$  partition: t.dim  $\leq$  splitVal}
        rhs  $\leftarrow$  {t  $\in$  partition: t.dim  $>$  splitVal}
        return Anonymizer(rhs)  $\cup$  anonymizer(lhs)
    else
        splitValue  $\leftarrow$  distinct-values(SplitAttribute)
        partition  $\leftarrow$  {t  $\in$  partition: t.dim = splitValue}
        return Anonymizer (partition)
    
```

---

Figure 6. XMondrian Algorithm

### 4. Dataset

The ADULT dataset acquired from the UCI Repository is utilized to compare diverse sorts of k-anonymity algorithms. The dataset consists of the statistics of 30,162 people from the US enumeration in 1990. The narrative for the ADULT Dataset is shown in Figure 7[9].

Number	Attribute	Card	Type
1	Age	74	Numerical
2	Gender	2	Categorical
3	Race	5	Categorical
4	Marital Status	7	Categorical
5	Native Country	41	Categorical
6	Work Class	8	Categorical
7	Occupation	14	Categorical
8	Education	16	Categorical
9	Income	2	Numerical

Figure 7. Description of ADULT Dataset

The below figure presents a descriptive example of 10 records of the ADULT Dataset.

ID	QID's				SA
Tuple.No.	Age	Workclass	Marital_Status	Native_country	Income
1	39	State-gov	Never-married	US	$\leq$ 50K
2	50	Self-emp-not-inc	Married-civ-spouse	US	$\leq$ 50K
3	38	Private	Divorced	US	$\leq$ 50K
4	53	Private	Married-civ-spouse	US	$\leq$ 50K
5	28	Private	Married-civ-spouse	Cuba	$\leq$ 50K
6	37	Private	Married-civ-spouse	US	$\leq$ 50K
7	49	Private	Married-spouse-absent	Jamaica	$\leq$ 50K
8	52	Self-emp-not-inc	Married-civ-spouse	US	$>$ 50K
9	31	Private	Never-married	US	$>$ 50K
10	42	Private	Married-civ-spouse	US	$>$ 50K

Figure 8. Sample Adult data

Figure 9 demonstrates a 2-anonymous edition of Figure 8, means each equivalence class has at least 2\*2-1 records same with respect to quasi identifiers. To attain anonymity, the direct identifier is expelled and the QIDs have been generalized .

EQs	QIDS				SA
1	[31-52]	Employed	*	US	>50K
	[31-52]	Employed	*	US	>50K
	[31-52]	Employed	*	US	>50K
2	[31-52]	Employed	*	US	<=50K
	[31-52]	Employed	*	US	<=50K
3	[31-52]	Private	Spouse-absent	North America	<=50K
	[31-52]	Private	Spouse-absent	North America	<=50K
4	[25-55]	Private	Married-civ-spouse	North America	<=50K
	[25-55]	Private	Married-civ-spouse	North America	<=50K
	[25-55]	Private	Married-civ-spouse	North America	<=50K

Figure 9. A2-Anonymous Version of Figure 8 after Applying Mondrian Algorithm

Figure 10. A 2-Anonymous Version of Figure 8 after Applying XMondrian Algorithm

EQs	QIDS				SA
1	[31-52]	Employed	*	US	>50K
	[31-52]	Employed	*	US	>50K
	[31-52]	Employed	*	US	>50K
2	39	State-gov	Never-married	US	<=50K
3	50	Self-emp-not-inc	Married-civ-spouse	US	<=50K
4	38	Private	Divorced	US	<=50K
5	49	Private	Married-spouse-absent	Jamaica	<=50K
6	[25-55]	Private	Married-civ-spouse	North America	<=50K
	[25-55]	Private	Married-civ-spouse	North America	<=50K

### 5.Comparison metrics

In terms of information loss and anonymization time, we equate our proposed algorithm XMondrian to the current algorithm. In certain cases, privacy-preserving algorithms alter datasets by adding false data or generalising and suppressing the original values. It's obvious that the more data is disguised, the less accessible it is for data analysts and researchers. As a result, the most important aspect of the metrics is quantifying the data quality after anonymization. There are a number of data quality indicators that can be used to measure the utility of data after it has been anonymized. 1) Average Equivalence Class Size Metric (CAVG) and 2) Anonymization Time are two common metrics for assessing data quality after anonymization.

#### 5.1. Average Equivalence Class Size Metric (CAVG)

This metric is to measure the average size of the equivalence classes (EQs) in the anonymized dataset. The aim of this metric is to reduce the penalty, so if CAVG is 1, it

implies that the anonymization is fine, with the size of the EQs equal to the provided K value. [2]. The total  $C_{AVG}$  score for an anonymized table  $T^*$  is given by:

$$C_{AVG}(T^*) = |T| / (|EQs| \cdot k)$$

Where T denotes the original table, |T| denotes the number of documents, |EQs| denotes the total number of equivalence classes generated, and k denotes the privacy requirement.[11]. Figure 9 which is obtained from Mondrian shows 4 EQs, and thus the  $C_{AVG}$  score for the whole table is calculated as:  $10 / (4 \cdot 2) = 1.25$  and consider Figure 10 which is obtained by applying Xmondrian Algorithm shows 6 EQs, and thus the  $C_{AVG}$  score for the whole table is calculated as:  $10 / (6 \cdot 2) = 0.8333$

### 5.2 Anonymization Time in seconds

Performance of the algorithms can be evaluated using anonymization time. The anonymization time of Xmondrian algorithm is less than Mondrian because Xmondrian algorithm doesn't require encoding and decoding of categorical values. We achieved 0.009 sec for Xmondrian while Mondrian algorithm was executed in 0.014 sec. This shows that Xmondrian performs better for any number of records. This is further explained in detail in Section 5.2.

## 6. Experimental Evaluation

### 6.1 Experimental Setup

To Experiment both Mondrian and Xmondrian algorithms, we used the adult datasets as described in Section 3. The configurations used in these experiments are shown in Figure 11: Various parameters in these experiments are:

- #QIDs : Defines Number of Quasi Identifiers
- k-value : Defines the privacy level
- Dataset size : Defines the number of records in the dataset.

Figure 11. Parameters chosen for Experimentation

Number	Experiment	Parameter Setting	Dataset(Size)
1	Varied #QIDs	k-value = 2 #QIDs ∈ [2..4]	ADULT (10)
2	Varied k-value	k-value ∈ [3...7] & #QIDs = 4	ADULT (50)
3	Varied Size	k-value = 2, #QIDs = 4	ADULT Dataset size ∈ [50...250]

### 6.2 Results

#### 6.2.1. Varied Dataset Size with constant K Value =2

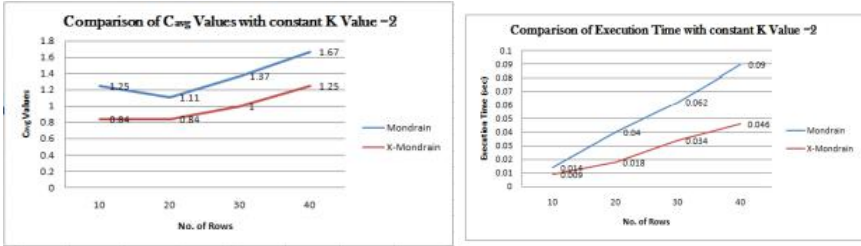


Figure 12. Varied Dataset Size with constant K Value =2

We can see that the Cavg values are getting closer to 1 and are slowly increasing as the number of rows increases, with a constant k value of 2. We can also compare the execution time with varied number of records and constant k value. The execution time always lesser for XMondrian compared to Mondrian. This proves that XMondrian is efficient when the data size is varied keeping the number of QIDs and K value to be constant.

#### 6.2.2 Varied K Values with constant Number of Rows

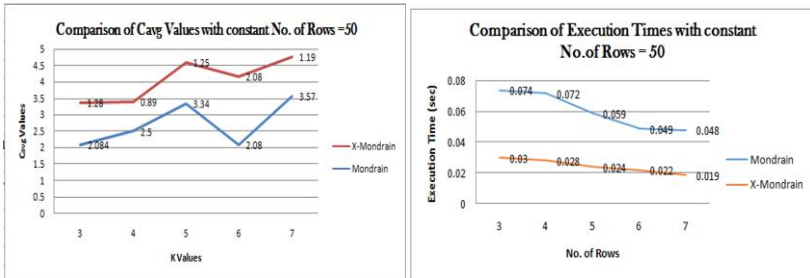


Figure 13. Varied K Values with constant Number of Rows

We can see that the Cavg values are closer to 1 and with varied trends with increase in the number of k values keeping number of rows and number of QIDs value as constant, while the Cavg values of Mondrian are extremely away from the equilibrium in case of increase in K value. We can also compare the execution time with varied K value and constant number of records = 50. The execution time is always lesser for XMondrian compared to Mondrian. The difference in the execution time between Mondrian and XMondrian is also significant. This proves that XMondrian is efficient when the K value is varied keeping the number of QIDs and data size to be constant.

### 6.2.3 Varied No. of QID

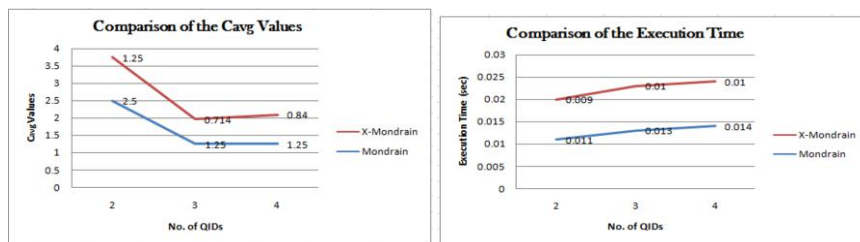


Figure 14. Varied No. of QID

We can see that the Cavg values are closer to 1 and with varied trends with increase in the number of QID values keeping number of rows and K value as constant, but it is not the case in Mondrian. We can also compare the execution time with varied number of QIDs value and constant number of records = 10 and constant K value being 2. The execution time is always lesser for XMondrian compared to Mondrian. This proves that XMondrian is efficient when the number of QIDs value is varied keeping the number of K value and data size to be constant.

## 7. Conclusion

We have conducted few experiments on both the algorithms to occur at conclusions on 3 important parameters to measure the data privacy and data loss. Cavg is (number of rows)/k\*(number of equivalent classes) When 'k' is made constant the number of equivalent classes determine the difference in Cavg between Mondrian and XMondrian. The number of partitions in XMondrian will be greater than or equal to the number of partitions in Mondrian generally. This can be based on the working of XMondrian. This algorithm groups like records together of categorical nature, whereas Mondrian splits the dataset into two parts per iteration depending on the median value. While the number of equivalent classes generated per iteration in XMondrian is not fixed. This tends to give 'x' number of partitions for a partition which might be greater than or equal to 2. This way XMondrian generates more partitions compared to Mondrian, which in turn gives lower Cavg value compared to Mondrian. This Cavg tends to have better proximity to 1, which is a more desired quality. The execution time of XMondrian is always lesser than Mondrian's. This reflects the fact that there is no need for encoding and decoding for categorical attributes. This time is reduced in the XMondrian algorithm. The excessive data that is stored online is invariably in the danger of being exploited. The privacy of data needs to be preserved, which is a topic of ethical considerations. With the implementation of our proposed algorithm, we can end the many issues related to unpreserved data. Throughout our paper we have tested the extended model of Mondrian called "The XMondrian", that has excelled in every aspect. It outshone the existing algorithm called Mondrian in all ways possible. Our test results have refined most of the features of Mondrian to give better results with our new algorithm. We intend to extend the scope of this experiment to the BigData and implement MapReduce version of XMondrian. This enables us to preserve the BigData with higher potency, in an efficient way[10].

## References

- [1] Machanavajjhala, A., Gehrke, J., Kifer, D., & Venkatasubramanian, M. (2006).  $t$ -Diversity, Privacy beyond  $k$ -anonymity. in Proceedings of the 22nd International Conference on Data Engineering, ICDE '06 (pp. 24). [1617392] (Proceedings - International Conference on Data Engineering; Vol. 2006). <https://doi.org/10.1109/ICDE.2006.1>
- [2] N. Li, T. Li and S. Venkatasubramanian,  $t$ -Closeness: Privacy Beyond  $k$ -Anonymity and  $l$ -Diversity, 2007 IEEE 23rd International Conference on Data Engineering, Istanbul, Turkey, 2007, pp. 106-115, doi: 10.1109/ICDE.2007.367856.
- [3] Fung, Benjamin & Wang, ke& Chen, Rui& Yu, Philip. (2010), Privacy-Preserving Data Publishing: A Survey of Recent Developments, ACM Comput. Surv..42. 10.1145/1749603.1749605.
- [4] Ghinita, G., Karras, P., Kalnis, P., & Mamoulis, N. (2007), Fast Data Anonymization with Low Information Loss. VLDB, 2007.
- [5] ArisGkoulalas-Divanis, Grigorios Loukides, Jimeng Sun, Publishing data from electronic health records while preserving privacy: A survey of algorithms, Journal of Biomedical Informatics, Volume 50, 2014, Pages 4-19, ISSN 1532-0464, <https://doi.org/10.1016/j.jbi.2014.06.002>.
- [6] Natgunanathan, Iynkaran& Xiang, Yong & Hua, Guang&Guo, Song. (2016). Protection of Big Data Privacy. IEEE Access. 4. 1-1. 10.1109/ACCESS.2016.2558446.
- [7] A. Mehmood, I. Natgunanathan, Y. Xiang, G. Hua and S. Guo, Protection of Big Data Privacy, in IEEE Access, vol. 4, pp. 1821-1834, 2016, doi: 10.1109/ACCESS.2016.2558446.
- [8] Latanyasweeney, . (2012),  $k$ -ANONYMITY: A MODEL FOR PROTECTING PRIVACY. International Journal of Uncertainty, Fuzziness and Knowledge-Based Systems, 10.10.1142/S0218488502001648.
- [9] K. LeFevre, D. J. DeWitt and R. Ramakrishnan, Mondrian Multidimensional  $K$ -Anonymity, 22nd International Conference on Data Engineering (ICDE'06), Atlanta, GA, USA, 2006, pp. 25-25, doi: 10.1109/ICDE.2006.101
- [10] Khan R, Tao X, Anjum A, Kanwal T, Malik SuR, Khan A, Rehman Wu, Maple C,  $\theta$ -Sensitive  $k$ -Anonymity: An Anonymization Model for IoT based Electronic Health Records. Electronics, 2020; 9(5):716. <https://doi.org/10.3390/electronics9050716>.
- [11] Ayala-Rivera, Vanessa & McDonagh, Patrick & Cerqueus, Thomas & Murphy, Liam. (2014), A Systematic Comparison and Evaluation of  $k$ -Anonymization Algorithms for Practitioners. Transactions on Data Privacy, 7,337-370.
- [12] Samarati P . Protecting respondents identities in microdata release. IEEE Transactions on Knowledge and Data Engineering, vol. 13, no. 6, pp. 1010-1027, Nov.-Dec. 2001, doi: 10.1109/69.971193.
- [13] Wei Fang, XueZhi Wen, Yu Zheng& Ming Zhou (2017), A Survey of Big Data Security and Privacy Preserving, IETE Technical Review, 34:5, 544-560, DOI: 10.1080/02564602.2016.1215269.
- [14] A. Gao and L. Diao, Privacy preservation for attribute order sensitive workload in medical data publishing, 2009 IEEE International Symposium on IT in Medicine & Education, Jinan, China, 2009, pp. 1140-1145, doi: 10.1109/ITIME.2009.5236250.
- [15] Q. Gong, M. Yang, Z. Chen and J. Luo, Utility enhanced anonymization for incomplete microdata, 2016 IEEE 20th International Conference on Computer Supported Cooperative Work in Design (CSCWD), Nanchang, China, 2016, pp. 74-79, doi: 10.1109/CSCWD.2016.7565966.



# Factual Question Generation System Using Pro Semantic Ranker

J Dafni Rose<sup>a,1</sup>, U Sakthi<sup>b</sup> and S S Ajithkumar<sup>c</sup>

<sup>a,b</sup>Dept of CSE, St. Joseph's Institute of Technology, Chennai, India

<sup>c</sup>Member Technical Staff Zoho Corporation, Chennai

**Abstract.** In today's internet world the amount of materials available to learn and gain knowledge is immense in numbers, which has given access to a lot of people to gain knowledge easily. Is it possible to find out if someone has read this sentence? To arrive at a conclusion of whether or not someone has read something, we can ask them to summarize its contents or question them about it. We can start with basic questions that deal with the title or the abstract, and progress to more challenging questions. A good example of this process would be a primary school teacher questioning his or her students on the basics of what they are reading to make sure that they are learning. It is a time-consuming process to create the basic questions and reading assessments that are commonly used, and can be quite taxing on the educator. This paper focuses on automating that time-intensive process. To be precise, this paper deals with the problem of generation of the factual questions in an automated manner from stand-alone texts.

**Keywords.** Question Generation, Pro Semantic Ranker, Natural Language Processing, Ranking

## I. Introduction

Asking questions from learners is said to facilitate interest and learning, to recognize problem learning areas to assess vocabulary and reading comprehension, to provide writing support, to support inquiry needs etc. The process of creating exercises and tests for practice is time and labour consuming, but has been an integral part of teaching for the longest time. With the rapidly expanding amount of learning material on the internet, there is an urgency to make this task scalable and less extensive. Subsequently, there is also a rising demand for intelligent tutoring systems that utilizes computer-generated or computer-assisted instructional material to evaluate the learner's comprehension. Inevitably, the task of the Automatic Question Generation (QG) caught the attention of NLP researchers from across the globe. Automatic QG has been defined as the task of automatically generating questions from various inputs like raw text, database or semantic representation". Apart from its direct application in the educational domain, in general, the core NLP areas like Question Answering, Dialogue Generation, Information Retrieval, Summarization, etc. also benefit from large scale

---

<sup>1</sup>DafniRose.J, Dept of CSE, St. Joseph's Institute of Technology, Chennai;  
E-mail: jdafnirose@yahoo.co.in

automatic Question Generation. The architecture diagram describes the main question. The paper is organized as follows. Section II includes the survey of how the questions are scored and ranked according to features of the source sentences, input sentences, the question, and the transformations used in the generation. Section III specifies the system functionality of pro semantic ranker. Section IV specifies the three stages of pro semantic ranker. Section V includes the performance analysis of proposed fog computing based smart knowledge based system. In the last section, we conclude some considerations and discuss future work of this research work.

## 2. Related Works

For the purpose of generating meaningful questions from the given natural language sentences, a neural encoder-decoder model is utilized [1]. The input text is read along with the answer position to generate an answer input representation. Question generation from supplied text using neural networks that automatically crawled and processed large-scale QA pairs from a community QA website was proposed in [2,1] and used as training data. Application of rules and templates to the given input's syntactic representation is how sentence-to-question transformation is carried out [3,7]. High levels of abstraction cannot be obtained in question generation using these syntactic representations. The semantic roles of words must be taken into consideration for there to be an elevated level of comprehension in the generated questions [4,5]. Removal of stop words is performed and Natural Language Processing is carried out. Key phrase extraction is done by using TF – IDF algorithm and checking the wiki presence of terms. The WordNet tool is used to for the creation of triplets for the generation of question papers as well as for the conduction of input clarity [6]. Automatic Question Generation (AQG) takes a passage and an answer as input. The aim of the AQG is to generate a respective question based on the input provided to it [5,3]. A process of generating questions that attempts to mimic a human approach of

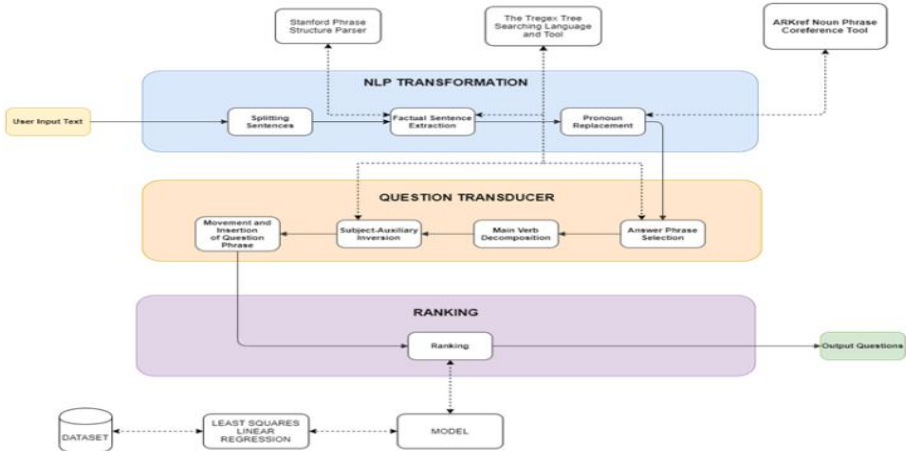


Fig 1 Architecture Diagram of Pro Semantic Ranker

Figure 1. Architecture diagram of pro semantic ranker

creating an initial draft of questions and subjecting that to refinement was proposed in [8] as a solution to this shortcoming [9].

### 3. Structure of Pro Sematic Ranker

The structure, views of a system and its behaviour is defined by the system architecture, which is conceptual. An architecture description represents the system formally, and is designed to support its structural and behavioural reasoning. Figure 1 depicts the architecture diagram of a pro semantic ranker. The first step is to extract relevant questions from the text file provided as input, containing the actual answers needed for the questions. After removing redundant text found in the file, relevant sentences containing answers can be extracted. Stage 2 involves the system taking a declarative sentence as input and processing it to generate a set of possible questions as output. The generated questions may be vague and users of this system only take into consideration a short set of candidate questions, making it very important to identify and present the questions that are most likely to be accepted first. Stage 3 of the system utilizes a statistical model to determine the question acceptability of each candidate question generated in stage 2 and ranks it accordingly. A data structure stores the generated questions and displays them in sets to the user when he or she is finished with studying. These questions can be taken as a form of revision or as a test.

### 4. Stages of Pro Sematic Ranker

The architecture diagram of the system defines the architecture of the main question generator, as well the process flows and dependencies required generating questions from the given input file. This system progresses over three stages namely, NLP transformation, Question transducer, and Ranking along with User Interface.

**Stage 1- Transforming Source Sentence:** Two forms of transformations are included in this operation. One of them deals with the extraction of simplified factual statements in sets from complex input sentences that have embedded constructions. The other form of transformation deals with replacing pronouns with their respective antecedents which takes place after the extraction of simplified statements.

**Stage 2: Question Transducer:** The system generates a set of possible questions derived from the declarative sentence it receives as input. Answer phrases that may potentially be targets for WH-movement are identified and converted into question phrases. Questions are not generated from all of the phrases of these types, or from verb phrases.

**Stage 3: Question Ranker and Statistical Model:** Users of this system only take into consideration a short list of candidate questions, making it very important to identify and present the questions that are most likely to be accepted first. Stage 3 takes the candidate questions obtained from Stage 2 and ranks them on the basis of question acceptability using a statistical model. The statistical model, along with its features is described in this section. The acceptability  $y$  of a question  $x$  is modelled is

$$y=w^t f(x)$$

Here,  $f$  is called as feature function. It produces a real-valued numbers vector that considers the various aspects of the question after processing the question provided as its input. The  $w$  used here is a vector of real-valued weight parameters for each feature in the feature vector returned by  $f$ . A weight vector  $\hat{w}$  is achieved that decreases the total adjusted errors on the training data values, matter to a consequence on the type of the weight vector, to evade over fitting.

$$\hat{w} = \underset{w}{\operatorname{argmin}} \sum_{i=1}^N \left( y_i - w^T f(x_i) \right)^2 + \lambda \|w\|_2^2$$

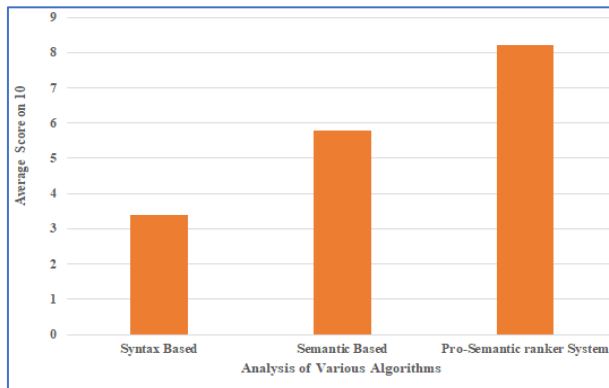
In the equation describes above,  $x_i$  is a particular occurrence in the training data, possessing an tolerability range of  $y_i$ , and  $N$  represents the count of trainings value of data. Such a format of linear regression is termed as edge regression.

## 5. Performance Analysis

The performance efficiency of factual question generation system using pro semantic ranker is analysed with various algorithms as shown in Table 1. The score obtained by various question generator system and the score is based on how much the question is semantically correct and whether it makes any sense is represented in Figure 2. From this table we can observe that the Pro-Semantic rankerSystem generates better and more semantically correct questions. Useful questions may often come across as semantic transformations of declarative sentences, or even as lexical and syntactic sometimes. This is carried out by transforming lexical items, semantics and syntactic structure.

**Table 1.** Average Score for various algorithms

Algorithms	Average Score on 10
Syntax Based	3.3
Semantic Based	5.8
Pre-Semantic Ranker System	8.2



**Figure 2.**Performance Comparisons

## 6. Conclusion

The proposed system of factual question generation helps in generating better and semantically correct questions when compared to the other traditional framework. It can also be widely adopted in online examinations for reading comprehensions by which malpractice can be avoided and can also be used to generate small unit tests in schools which enables the students to learn the concepts then and there. Automatically generating factual questions is a problem that is only slightly acknowledged in this proposed process. The system utilizes high-level semantic types with a super sense tagger to annotate source sentences and thereby generate question phrases.

## References

- [1] Qingyu Zhou, Nan Yang, Furu Wei, Chuanqi Tan, Hangbo Bao, Ming Zhou. Neural Question Generation from Text: A Preliminary Study. Apr 06, 2017.
- [2] Nan Duan, Duyu Tang, Peng Chen, Ming Zhou . Question Generation for Question Answering .Sep 2017.
- [3] Onur KEKLIK, Automatic Question Generation using Natural Language Processing Techniques, July 2018 IZMIR
- [4] K.Surya, R.Aarthipriya, S.Iswarya .Automatic Question and Answer Pair Generation.Special Issue Published in International Journal of Trend in Research and Development (IJTRD), ISSN: 2394-9333, www.ijtrd.com, Sep 15, 2016
- [5] Xingdi Yuan, Tong Wang, Caglar Gulcehre, Alessandro Sordani, Philip Bachman, Sandeep Subramanian, Saizheng Zhang, Adam Trischler, Machine Comprehension by Text-to-Text Neural Question Generation, Aug 3, 2017
- [6] Aleena Susan Mathew, Vidya. N, Implementation of Automatic Question Paper Generator System, International Research Journal of Engineering and Technology (IRJET) Volume: 06 Issue: 02, Feb 2019.
- [7] Han Xiao, Feng Wang, Jianfeng Yan, Jingyao Zheng, Dual Ask-Answer Network for Machine Reading Comprehension, Sep 10, 2018.
- [8] Xingdi Yuan, Tong Wang, Caglar Gulcehre, Alessandro Sordani, Philip Bachman, Sandeep Subramanian, Saizheng Zhang, Adam Trischler, Machine Comprehension by Text-to-Text Neural Question Generation, May 15, 2017.
- [9] Ambeth Kumar.V.D .Precautionary measures for accidents due to mobile phone using IOT. Clinical eHealth, Volume 1, Issue 1, March 2018, Pages 30-35.

# Improved Linearly Constrained Minimum Variance Algorithm for 5G Communications System

Kaviya K R<sup>a,1</sup> and Deepa S<sup>b</sup>

<sup>a</sup>PG Scholar, Dept of ECE, Panimalar Engineering College, Chennai, India

<sup>b</sup>Professor, Dept of ECE, Panimalar Engineering College, Chennai, India

**Abstract.** Beamforming is a process formulated to produce the radiated beam patterns of the antennas by completely building up the processed signals in the direction of the desired terminals and cancelling beams of interfering signals. Adaptive beamforming is a key technology of smart antenna. The core is to obtain optimum weights of the antenna array by some adaptive beamforming algorithms and finally adjust the main lobe to focus on the arriving direction of the desired signal as well as suppressing the interfering signal. There are several beamforming algorithms that includes Linearly Constrained Minimum Variance (LCMV) algorithm in which Self Nulling Issue is further reduced by adding multiplier to the MCMV algorithm and it is referred as Improved LCMV (IMPLCMV). A Comparative analysis is done for different multipliers and it is found that  $w=0.15$  gives best result with minimum interference of flat response and also self-nulling issues can be reduced.

**Keywords.** Adaptive Beamforming, improved LCMV, performance, measurement.

## 1. Introduction

5G wireless technology delivers higher multi- Gbps peak data speeds, low latency, more reliability, massive network capacity, increased availability and a more uniform user experience to more users. MIMO systems require a combination of antenna expansion and complex algorithms. It is multifaceted, but MIMO has been used in wireless communications for a long time, now it is common for both mobile devices and networks to have multiple antennas to enhance connectivity and offer better speed. MIMO algorithms come into play to control, how data maps into antennas and where to focus energy in space. The beamforming or spatial filtering is a signal processing technique used in sensor arrays for directing signal transmission or reception. An adaptive beam former is a system that performs adaptive spatial signal processing with an array of transmitters or receivers. The signals are combined in such a way that, signal strength is increased.

---

<sup>1</sup> Kaviya K R, PG Scholar, Dept of ECE, Panimalar Engineering College, Chennai;  
E- mail: kaviyakr1997@gmail.com

## 2. Related Works

Orthogonal frequency division multiplexing (OFDM) has been extensively considered as an constructive modulation technique for reducing the effects of inter symbol data rate transmission over wireless links[1]. A new algorithm for downlink multiuser beamforming in mobile communications is narrated [2]. A hybrid beamforming algorithm utilizing a subset of array elements according to receive signal strength is proposed [3]. Three adaptive beamforming algorithms are proposed that have a prescribed quiescent beam pattern and utilize the remaining degrees of freedom to reduce interference [4]. A new perturbation technique is proposed which enables adaptive beamforming (ABF) in microwave domain using a single-port beam former[5].

## 3. Structure Description and Analysis

Beamforming or spatial filtering is a signal processing technique used in sensor arrays for directional signal transmission or reception. This is achieved by combining elements in an antenna array in such a way that signals at certain angles experience constructive interference while others experience destructive interference. Beamforming can be used at both the transmitting and receiving ends in order to achieve spatial selectivity. It can be used for radio or sound waves. It has found numerous applications in radar, sonar, seismology, wireless communications, radio astronomy, acoustics and biomedicine. As the name indicates, an adaptive beam former is able to automatically adapt its response to different situations. Some criteria has to be set up, to allow the adaptation to proceed such a way that, total noise output is minimized as shown in Fig1. Because of the variation in noise with frequency, wide band systems may be desirable to carry out the process in the frequency domain. An adaptive beamforming uses different information for updating its beamforming weight to adapt with the situation and perform accordingly.

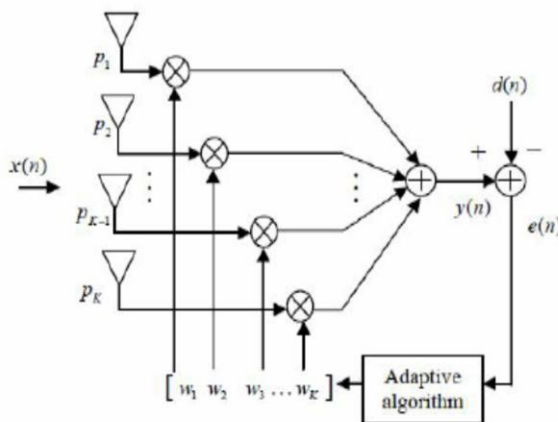


Figure 1. Structure of Adaptive Beamforming

### 3.1. Smart Antennas

Smart antenna (also known as adaptive array antenna) refers to a system of antenna arrays with smart signal processing algorithms that are used to identify spatial signature such as direction of arrival (DOA) of the signal and it is used to calculate beamforming vectors, to track and locate the antenna beam on the mobile or target. A smart antenna system is an integration between array antenna elements and digital signal processing techniques. An Array signal processing involves the manipulation of signals induced on the elements of an array antenna.

### 3.2. Phased Array

In antenna theory, a phased array usually means an electronically scanned array, a computer-controlled array of antennas which creates a beam of radio waves that can be electronically steered to point in different directions without moving the antennas. In a simple array antenna, the radio frequency current from the transmitter is fed to the individual antennas with the correct phase relationship so that the radio waves from the separate antennas add together to increase the radiation in a desired direction and to suppress in undesired directions.

## 4. Linearly Constrained Minimum Variance Algorithm

The majority of designed beamforming algorithms require some knowledge of the reference signal and the strength of the desired signal. These limits can be overcome by applying linear constraints to the weight vector.

## 5. Proposed Work

In MVDR, self nulling issue is the major disadvantage which is overwhelmed in Linearly Constraint Minimum Variance (LCMV) algorithm. It is further reduced by calculating weights, which is referred as Improved LCMV (Imp LCMV). The comparative study of different weights ( $w=0.15, 0.35, 0.5, 0.65, 0.8$ ) is analyzed and the best one is selected among them. The weights can be chosen according to the application.

### 5.1. Improved LCMV

In Improved LCMV, the weights are added which is represented by  $m$  to further enhance the self-nulling issues. The Improved LCMV filter generalizes LCMV by reconstructing simultaneously  $n$  sources  $s_{qi}$ ,  $i=1, \dots, n$ . Specifically, a  $(n \times 1)$  vector of source amplitudes  $s = \{s_{q1}, \dots, s_{qn}\}$  is represented as

$S(t) = W^T b(t)$  with  $W$  being a  $(M \times n)$  matrix of weight vectors corresponding to each source:  $W = \{w_{q1}, \dots, w_{qn}\}$ . Weights  $W$  are selected so as to minimize total average reconstructed source power  $\sum_{i=1}^n \langle s_{qi}^2 \rangle = \langle |s|^2 \rangle$  subject to a constraint  $W^T H = I_n$ . Here, a  $(M \times n)$  joint forward solution matrix  $H = \{h_{q1}, \dots, h_{qn}\}$  is defined and  $I_n$  is an  $n$  dimensional identity matrix, The minimum power is given by ,

$$W = R^{-1} H (H^T R^{-1} H)^{-1} \quad (1)$$



```
Imp LCMV= m LCMV*0.5; hold on; % compare to MVDR pattern(ula,carrierFreq,-
180:180,0,'Weights',impLCMV,...'PropagationSpeed', physconst('Light Speed'),
'Normalize', false,... ' Type', 'powerdb ', 'Coordinate System', 'rectangular');
```

### 6. Result and Discussion

From the above proposed work, it is seen that the weights (w) can be added increasingly or decreasingly according to our application required. Here, different weights are being analyzed and the least angle is chosen as the best one, due to its less nulling issues. A comparative analysis of IMP LCMV for different weights is shown in Table 1. The data can be stored via edge computing, so that response time can be improved in future work .

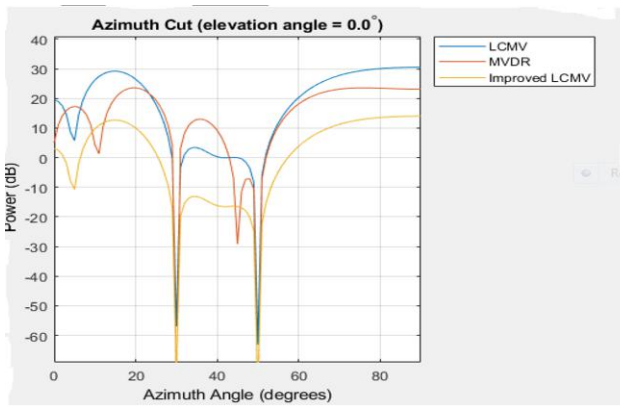


Figure 2. Self Nulling at w=0.15

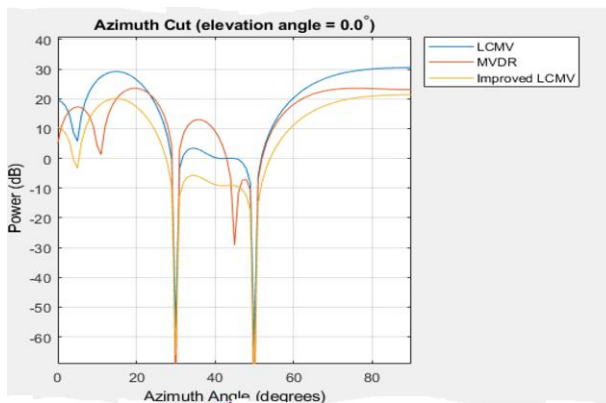


Figure 3. Nulling issue at w= 0.35

Fig. 2 & 3 represents the point at which the nulling issue is reduced so that the interference problems can be minimized. From the above two cases, it is found that case 1 gives best result, because it produces flat response at its low power and also the nulling issue is further reduced.

**Table 1.** Different X and Y values for different weight

Weights	X	Y
0.15	77	+20.506
0.35	77	+13.147
0.5	78	+23.7596
0.65	78	+26.03
0.8	78	+27.842

Table.1 represents the power and angles for different increasing weights. The analysis shows that  $w=0.35$  shows the best result because of its low power and also the nulls are reduced.

## 7. Conclusion

The self nulling issue is overwhelmed in Linearly Constraint Minimum Variance (LCMV). From the analysis, the self nulling issue is further reduced in Improved Linearly Constraint Minimum Variance (Imp LCMV) Algorithm. The self nulling issue is analyzed for five different weights. (weights at  $w=0.15, 0.35, 0.5, 0.65, 0.8$ ). It is found that  $w=0.35$  gives the best result when compared to other values. Further, the convergence rate for different SNR can be calculated so that the LCMV will be more suitable for many applications.

## References

- [1] Ya-Han Pan and Khaled Ben Letaief ,Dynamic Spatial Sub channel Allocation With Adaptive Beamforming for MIMO/OFDM Systems, IEEE Transactions On Wireless Communications, VOL. 3, NO. 6, November2004.
- [2] Nanyan Wang, PanajotisAgathoklis, and Andreas Antoniou .A Subspace Multiuser Beamforming Algorithm for the Downlink in Mobile Communications. IEEE Transactions On Circuits And Systems—II: express briefs, VOL. 53, No. 8, August2006
- [3] Ya-Han Pan and Khaled Ben Letaief . Dynamic Spatial Sub channel Allocation With Adaptive Beamforming for MIMO/OFDM Systems. IEEE Transactions On Wireless Communications, VOL. 3, NO. 6, November2004
- [4] Nanyan Wang, Panajotis Agathoklis, and Andreas Antoniou .A Subspace Multiuser Beamforming Algorithm for the Downlink in Mobile Communications. IEEE Transactions on Circuits and Systems—II: express briefs, VOL. 53, No. 8, August2006
- [5] Nuri Celik, Wayne Kim, Mehmet F. Demirkol, Magdy F. Iskander, Rudy Emrick ,Implementation and Experimental Verification of Hybrid Smart- Antenna Beamforming Algorithm, IEEE Antennas And Wireless Propagation Letters, VOL. 5,2006
- [6] Spyridon Vassilaras and George C. Alexandropoulos. Cooperative Beamforming Techniques for Energy Efficient IoT Wireless Communication. 2017 IEEE International Conference on Communications (ICC), May 2017
- [7] Maheshwari, M. K., Agiwal, M., Saxena, N., & Roy, A. (2017). Flexible Beamforming in 5G Wireless for Internet of Things. IETE Technical Review, 1–14
- [8] K.R Kaviya and Deepa S .An Inclusive Survey on Various Adaptive Beamforming Algorithms for 5G Communication Systems Journal[IOS-Press], Scopus, doi:10.3233/APC2001.

# A Generic System for Processing Insurance

Samundeswari S<sup>a,1</sup>, Jeshoorin G<sup>b</sup>, Vasanth M<sup>b</sup>,

<sup>a,b</sup>Department of CSE, Sri Sairam Engineering College, Chennai, India

**Abstract.** Insurance companies are regularly provided with health check reports by the buyers of insurance. Different forms of printed lab reports / health check reports have to be digitized for each value of captured parameters. Optical Character Recognition (OCR), is used to convert the images of handwritten, typed, printed text or any kind of scanned documents into machine-encoded text in order to digitize the values from the report. Conversion to this standard set of digital values will benefit in automating a lot of backend approval process. we collect the reports from the user and read the values from the report and scrutinize the values. Based on the values with the company's standard set, the scrutinization is done and it is then visualized using any visualization tool. The result is presented to the user so that the user can get an idea whether he/she is eligible for insurance claim. The foremost objective of this paper is making the insurance backend approval process a lot easier and a quick response to the buyers.

**Keywords.** Optical Character Recognition, Insurance, Visualization, digitization.

## 1. Introduction

Insurance can help the people to protect from loss. It's protection from a variety of risk, primarily made up against the chance of untimely or uncertain loss. Figure 1 shows the number of policies taken by customers taken on various sectors. A person who provides insurance is considered as an insurer, underwriter, insurance carrier or insurance underwriter. Someone or a person who buys insurance is considered as an insured or as a policyholder. The loss or event of loss occur may or might not be of financial manner, but it is converted to financial terms, and often has something with which the insured customer has an interest over by ownership, or possession of the product, or have pre relationship. The insured person is provided with a contract, called the contract, which have a detailed conditions and circumstances under which the insurance company will provide the compensation to the insured person. The amount of cash charged by the insurance company to the customer for the policy from the insurance company is termed as premium.

---

<sup>a</sup>Samundeswari S, Department of CSE, , Sri Sairam Engineering College, Chennai, India  
Email: samundeswari.cse@sairam.edu.in

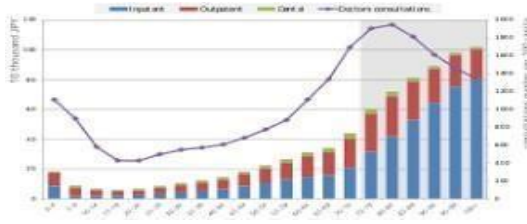


Figure 1. Graph Representing number of policies taken by Customers on Healthcare Sector.

1.1 Scope of project

- i) This method is utilized by any company which has great amount of data and wishes to scrutinize them easily.
- ii) This work also helps the shoppers get their insurance as soon as possible after processing their report.
- iii) This work helps the workers to cut back their work load by scrutinizing the specified reports where human errors will be avoided.

2. Domain Overview

Machine learning involves the detailed study of computer algorithms that plays a major role in automating and improving automation through experience. It's a subdomain of Data Science. Machine learning algorithms (ML) are used to build a mathematical model supported by sample data and training set, remarked as "training data", to create decisions or predictions without writing explicit programs to do. Machine learning algorithms are widely used in a variety type of real time applications, like email filtering, computer vision, where it's very difficult or impossible to develop mathematical algorithms to perform the assigned tasks. Machine learning is closely related to statistics and probability, which is used for prediction using data set. Processing is a field of study, specialized in data analysis through any type of unsupervised learning.



Figure 2. Process Flow of Character separation from images

2.1 Working of OCR

Google's Tesseract is an open-source text recognition (OCR) Engine. It is either used directly using flask, or using an API to extract texts from images. It supports a wide and all kinds of languages. Google Tesseract doesn't have a built-in user Interface, but there are several available for taking from other sources. Tesseract goes hand in hand with many programming languages and made up of frameworks by using wrappers, Fig 3 shows the working of google Tesseract OCR. It can also be used with the already existing layout analysis from various sources to recognize text from any document.

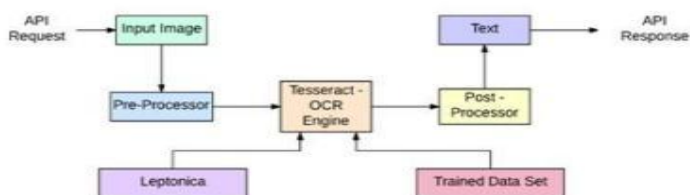


Figure 3. OCR Process Flow

## 2.2 Constraints

Existing systems are primarily built around one or two core functionalities and fail to integrate all the features that would provide a complete solution towards improving patient comfort and self-reliance at an affordable cost. Some of the early versions of such stature remain costly or inaccessible to the public outside of their places of origin.

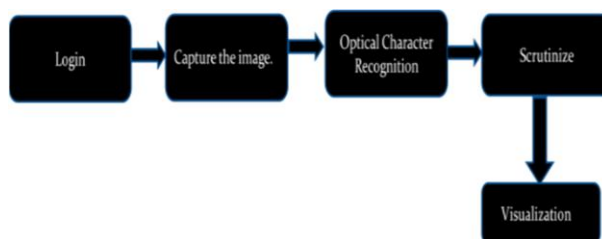


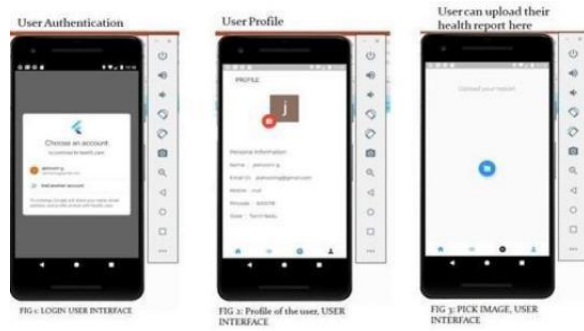
Figure 4. Block view showing the overall system implementation

## 3. System Implementation

Optical Character Recognition (OCR) which is an electronic or mechanical conversion of images of typed handwritten or printed text into machine encoded text. OCR helps to get the data from the printed lab reports / health check reports to discrete values of each parameter. JSON is a key-value pair output from OCR, which is easy for the Application, to extract the information from the report and send it to the database. The application is developed in such a way where the data received from patient's report is scrutinized and the data is visualized using Google charts.

### 3.1 Designing The Ui And Uploading The Image To The Firebase

The user Can Using the various Social platform (Google, Facebook....) provided on the login page. The packages package:/.dart and package:/.dart are imported for the above task. Once the sign in takes place two tokens are returned as a result ("Access token" and "ID Token"). Using the Access Token, the information of the user is taken from the user's profile on the signed in social account. Then the details are stored for future purposes. The data of the user stored. If the user chooses to upload his profile pic it is



**Figure 5.** User Interfaces showing login, profile and image upload screen

stored in the application. Claim pages is where the user gets the status of his/her insurance processing status can also view the reports uploaded by the user, since the usage of application in reports page Figure 6 shows the User Interfaces of login, profile and image upload screens.

### 3.2 Getting Values From The Report

The link generated is then passed on to a private OCR by using API. Newer Version of Tesseract supports a new neural net-based engine which is all about line recognition and used in paper [2][3][5]. Tesseract also has Unicode support, and can recognize more than n number of languages. Tesseract provides supports for various output formats such as: Portable Document Format (PDF), plain text, invisible text PDF, Tab Separated Values (TSV). The support for ALTO (XML) output.is just experimental as provided by Optical Character recognition (OCR) tool present in python. what it means is that it is able to recognize the text embedded or present in images. Python tesseract is a type of wrapper using Google's Tesseract OCR Engine. It is always a pretty useful stand-alone invocation script tool for invocation of tesseract, since it is able to read all images supported by the Pillow and imaging.

### 3.3 Scrutinizing, Visualising The Data And Backend Processing

The incoming data is accessed using Flask, and have to use the request object. The request object gets holds of all the incoming data from the request, which also includes the mime type, referrer, raw data, HTTP method, and even headers. For easily gaining access to the request object provided to the Flask, we can simply import it from Flask library. The Result is then stored in a variable called reply from which u can get the data and scrutinize the data based on needs. The Sync fusion Flutter Charts package is one of the data-visualization libraries written in Dart for creating a beautiful and high-performance chart which is also used in the paper [6][9]. Figure 6 shows a sample screen of the results, which is obtained from the medical report. Based on the data, we initialize the appropriate axis type and series type.



**Figure 6.** Results obtained from the medical report

#### 4. Conclusion

This paper outlined the practical implementation of the Digitization of insurance approval by which a lot of time can be saved. This method can be used by any company which has large amount of data and needs to scrutinize them based on the conditions. This project also helps the customers get their insurance as soon as possible after scrutinizing their report. This project helps the employees to reduce their work load by scrutinizing the required reports where human errors can be avoided.

#### References

- [1] A. C. Downton, A. Amiri, L. Du and S. M. Lucas, "A configurable toolkit approach to handwritten forms recognition," IEE Colloquium on Document Image Processing and Multimedia Environments, London, UK
- [2] Adapting the Tesseract Open Source OCR Engine for Multilingual OCR Ray Smith, Daria Antonova, Dar Shyang Lee Google Inc., USA.
- [3] Unnikrishnan, R., Smith, R., Combined Script and Page Orientation Estimation using the Tesseract OCR engine Submitted to International Workshop of Multilingual OCR, 25th July 2009, Barcelona, Spain.
- [4] Creation of custom recognition profiles for historical documents Adam, and Tomasz Parkoła Poznań and Networking Center.
- [5] An Overview of the Tesseract OCR Engine, Ray Smith, Google Inc.
- [6] An Interactive Document Image Description for OCR of Handwritten Forms David Monger, Graham Leedham and Andy Downton University of Essex, United Kingdom .
- [7] G. Leedham and D. Monger, "Evaluation of an interactive tool for handwritten form description," Proceedings of 3rd International Conference on Document Analysis and Recognition, Montreal, Quebec, Canada.
- [8] Data visualization literacy: Definitions, conceptual frameworks, exercises, and assessments Katy ,1, and Michael a School of Informatics, Computing, and Engineering, Indiana University,
- [9] I. Lee PS, West JD, Howe B (2018) Vizometrics: Analyzing Visual Information in the Scientific Literature. IEEE Transactions on Big Data 4(1):117–129.
- [10] Borkin MA, et al. (2016) Beyond Memorability: Visualization Recognition and Recall. IEEE Trans Vis Comput Graph 22(1):519–528.
- [11] Gingerich O, van Helden A (2003) From Oculi to printed page: the making of Galileo's Sidereus nuncius. Journal for the History of Astronomy 34:251–267.
- [12] P. V. Klaine, M. A. Imran, O. Onireti and R. D. Souza, A Survey of Machine Learning Techniques Applied to Self Organizing Cellular Networks, in IEEE Communications Surveys & Tutorials, vol. 19, no. 4, 2018.
- [13] B. Akshaya, M. Rajendiran. Securing Documents Using Digital Certificate-A Review. International Journal of Research in Advent Technology (IJRAT) , 2018
- [14] M. Dhivya, K. Valarmathi .IoT Based Smart Electric Meter. Lecture Notes on Data Engineering and Communication Technologies, volume 35, pp 1260-1269, 2020.
- [15] R. Vidhya, K. Valarmathi. Automatic Monitoring of Hydroponics System Using IoT. Lecture Notes on Data Engineering and Communication Technologies, volume 35, pp 641-648, 2020
- [16] Rajamani.V, Murugavalli.S .A High Speed Parallel Fuzzy C-means algorithm for Tumor Segmentation .ICGST International Journal on BIME 6 (1), 2006

# A Survey on HetNet to Enhance QoS in 5G Network Using Various Techniques

Lydia Sharon Rose G<sup>a,1</sup> and Ameelia Roseline A<sup>b</sup>

<sup>a</sup> PG Scholar, Dept of ECE, Panimalar Engineering College, Chennai, India

<sup>b</sup> Professor, Dept of ECE, Panimalar Engineering College, Chennai, India

**Abstract.** HetNet (Heterogeneous Network) has been suggested for next age group wireless systems to meet the exceptional difficulties of advanced data rates. The specifications for various levels of QoS (Quality of Service) from various kinds of wireless requests and service areas are met. In this HetNet in to improve the QoS and SINR (Signal to Interference plus Noise Ratio), many techniques have been performed to provide satisfactory outcomes. This paper gives a comparative survey on the QoS and various techniques used, which are used to enhance QoS.

**Keywords.** QoS, HetNet, SINR

## 1. Introduction

HetNets play a vigorous role in imminent 5G wireless cellular network arrangement. Low latency, fast throughput, improved scalability, high consistency, and energy efficient networking infrastructure are all features of the 5G network. HetNets are used to enhance the QoS, which is mostly operated in the network layer ie layer 3. QoS is used to control traffic and ensure performance. It enables to adjust the overall network by prioritizing precise high-performance applications. QoS depends on the number of users and traffic demands.

## 2. Related works

Fabio de Oliveira Torres et.al [1] Using computational intelligence methods, investigate a reduction of interference paradigm between SC (Small Cells) in a complex environment. It was discovered that issues relating to the system's complete observation were successful by using Gas (Genetic Algorithms). Improvements found during the simulations in the QoS were reduced by lag above 33 percent and found a drop in metaheuristic, the co-channel interfering was decreased, and the SINR was increased by 80 percent.

---

<sup>1</sup>Lydia Sharon Rose G, Dept of ECE, Panimalar Engineering College, Chennai, India,  
Email: sharonroselydia@gmail.com



Tahseen Ul Hassan et.al [2] projected the fantastic solution for femtocell, developed an expanding exposure and divesting data from existing LTE cellular networks. This paper adopts the APC (Active Power Control) methodology to achieve a greener femtocell by reducing ICI (Inter-Cell Interference) in an MUE (Macro User Equipment) while also reducing needless power usage. The simulation outcomes demonstrate that using the APC technique lessens ICI and enhances the MUE's throughput efficiency. The APC method strikes a balance between achieving the FUE's (Femto User Equipment's) required QoS and lowering MUE, the survivor of ICI.

Jun Zhu et.al [3] proposed that in a HetNet a less power indoor femtocell was installed in the current MBS's (Macro Base Station's) service area. FAP (Femtocell Access Point) is a low cost and power indoor wireless contact network that offers the highest speed coverage and shortest-range coverage area. The FAP satisfies the QoS needs of consumers who are supported by MBS and FAP. Consumers who are assisted by MBS and FAP have their QoS requirements fulfilled by the FAP. The efficiency of a low difficulty in QACS, a macro femto HetNet system based on arbitrary beamforming broadcast was developed.

Zeju Wang et.al [4] introduces Hetnet has integrated the Cloud-RAN (Cloud Radio Access Network), a lowest-cost cellular network distribution tool to a disturbance management system and spectral capacity management. To gain useful spectral tools, spectral efficiency, QoS are comprehensively considered. The probability of weighted dependent spectral resources allocation algorithm was suggested to solve the optimization problem. Consequently, led to the expected algorithm has a developed a reduced likelihood of macrocell consumers suffering outages and frequency reuse efficacies.

Jingmiao Wu et.al [5] proposes that in HetNets DUDE (Downlink and Uplink Decoupling) is an idea for enlightening the uplink presentation. This uses uplink interference moderation through frequency reuse and power control schemes. Therefore, to improve the performance of the system's range utilization and uplink users DDPC (Dynamic Distributed Power Control) is utilized. SINR thresholds were maintained at all time. The simulation results show that QoS and uplink data rate performance were better.

Imad Al-Samman et.al [6] In systems, intra and inter tier interference have an overall success has a huge influence as a result spectral resource management and interference became more difficult. HetNet networks use C-RANs. To accomplish interference management and useful spectral resources, the HetNet and C-RAN were used. This paper suggests a user-weighted probability algorithm for distributing suitable spectrum barriers to each BS to meet maximum user throughput and specific QoS requirements.

L. Manjunath et.al [7] proposed the task of meeting, high data rates the ever-increasing request while maintaining a consistent QoS in the network. One of the most significant in the use of communication technologies and data is it consumes less energy. It creates hardware by merging interface mitigation and base position of switch-off techniques.

Zeinab A. aboelezz et.al [8] proposes that one of the significant processes ishandover, which has an impact on QoS. Based on the handover process, this paper proposes a fuzzy logic technique to estimate LTE networks in QoS. Many precepts in the fuzzy technique are grouped as many staged fuzzy logics, which have been reduced. QoS is calculated in three stages which provide 100% with low jitter, high throughput, and low loss rate, low network delay are all constraints.

Muhammad usman Iqbal et.al [9] proposed that HetNets can only be used if an algorithm that is adaptive and self-organizing the current conditions is used. SC-based

ultra-dense HetNets are evaluated using a QL (Q-Learning) based adaptive resource allocation scheme. This solution guarantees a QoS to 16 SCs and the measurements of SUE (Small cell User Equipment) was about 1.5 b/s/Hz.

Zeeshan Kaleem et.al [10] proposed that the HetNets two-tier is a concept in which short-range and low-power femtocells are used to meet QoS requirements which are kept placed beneath macrocells. In this paper, one of the main problems that have been addressed so that the HetNets to be successfully deployed is co-channel interference. FFR (Fractional Frequency Reuse) systems have been anticipated in a way to make the most of the fields available. A QoS-DFFR (Quality of Service-based Dynamic FFR) scheme was also suggested. Waleed AlSobh et.al [11] proposed that the main involvement is machine learning style QL control algorithms that are existing in the downlink to optimize the power of 5G networks. This paper suggests two QL algorithms for allocation of power: formulated and distributed algorithms. The distributed technique algorithm outstripped the cooperative and formulated approaches. The number of MUE-QoS of FUEs served grew to the detriment.

Jihene Ben Abderraza et.al [12] inspects how to boost the consumer association and the Almost Blank Subframe (ABS) ratio calculation in HetNets at the same time. In a two-tier HetNet, this paper proposes a unified heuristic algorithm for obtaining the correct ABS ratio while increasing the user's number. SINRs can be detected in sub-bands of both secured and exposed techniques. Ying Loong Lee et.al [13] The tools and techniques challenge for LB (Backhaul Load Balancing) and QoS in HetNets is discussed in this paper. For HetNets, a user alliance technique was proposed to accomplish backhaul LB and QoS utilization. In respect of QoS, call blocking probability, and justice, simulation results reveal that the proposed plan outperforms the current user association technique.

### 3. Literature survey

**Table 1.** Design Specification on existing work for different metrics.

.NO	TECHNIQUES USED	QoS ACHIEVEMENT	SINR ACHIEVED	PARAMETER METRIC
[1]	Generic algorithm (GA)	Improved with a lag of 33%	80%	-
[2]	Active Power Control (APC) technique	Provides balanced tradeoff	-	The power saved by 13.51%
[3]	Coordinated random beamforming and user scheduling strategy	QACS makes it improved	Satisfies femto-MT (macro-MT)	Throughput is improved

[4]	Weighted-based Spectral Resource Allocation algorithm and CRAN	-	Hetnet's spectral resource distribution optimization problem was taken into consideration.	-	Frequency reuse and efficiency is improved
[5]	Downlink and Uplink Decoupling (DUDE)& Using frequency reuse and power management systems, the uplink interruption may be reduced.	Better		SINR of the DUDE scheme is 83% in RFA.	Uplink data rate performance is better
[6]	User weighted probability-based algorithm	Improved		-	Cost effective and Spectral efficiency is better
[7]	interference management algorithms & backhaul	Stable		-	-
[8]	Handover and QoS Control and Fuzzy logic design	100%		-	low loss rate, high throughput, low network delay, and low jitter.
[9]	Q-learning and machine learning	Increased by 37.5%SCs & 33% higher than the minimum required QoS		-	-
[10]	Fractional Frequency Reuse (FFR) scheme	Performs remarkably high		-	Reduced packet loss and high throughput
[11]	Distributed and Formulated are two Q-learning algorithms for Power Allocation.	Increased value		-	The number of served FUEs increased.
[12]	Centralized heuristic algorithm	Minimized		-	-
[13]	Backhaul Load Balancing (LB)	satisfies UEs		lower blocking probabilities at 150 and 200UEs	-

The analysis of various design specification on existing work for different metrics has been discussed and shown in Table 1. This table is based on techniques used, QoS, SINR and, parameter metrics on each paper were compared.

#### 4. Conclusion

This paper has investigated the problem related to, Quality of Service (QoS) which has been enhanced in heterogeneous networks (HetNets) using various techniques and the problems related to (SINR) Signal to Interference plus Noise Ratio have been compared.

## References

- [1] Fabio de Oliveira Torres 'a, Diego LisboaCardosoa , Luiz Felipe Coelho e Silvaa. Interference mitigation in next generation networks using clustering and intelligence techniques. *Procedia Computer Science* 94 (2016) 280 – 287, 1877-0509 DOI: 10.1016/j.procs.2016.08.042.
- [2] Tehseen Ul Hassan and Fei Gao. An Active Power Control Technique for Downlink Interference Management in a Two-Tier Macro-Femto Network. 2019 May 19(9): 2015, Published online 2019, Publisher: IEEE.
- [3] Jun Zhu, Hong-Chuan Yang. Low-Complexity QoS-Aware Coordinated Scheduling for Heterogeneous Networks. *IEEE Transactions on Vehicular Technology* (Volume: 66, Issue: 7, July 2017), Page(s): 6596 – 6601, Date of Publication: 15 November 2016, NSPEC Accession Number: 17026924, DOI: 10.1109/TVT.2016.2628387, Publisher: IEEE.
- [4] Zejue Wang, Hongjia Li, Heng Wang, and Song Ci. Probability Weighted Based Spectral Resources Allocation Algorithm in Hetnet under Cloud-RAN Architecture. *The First IEEE ICC International Workshop on Internet of Things (IOT 2013)*, 978-1-4799-1403-6/13/\$31.00, Page (s): 88-92, Publisher: IEEE.
- [5] Jingmiao Wu, Kai Sun, Wei Huang . Uplink Performance Improvement by Frequency Allocation and Power Control in Heterogeneous Networks. 2018 24th Asia-Pacific Conference on Communications (APCC), Page(s): 364-369, Publisher: IEEE.
- [6] Imad Al-Samman, Reham Almesaedi, Angela Doufexi, Mark Beach and Andrew Nix, User Weighted Probability Algorithm for Heterogeneous C-RAN Interference Mitigation, 2017 IEEE International Conference on Communications (ICC), Date of Conference: 21-25 May 2017, INSPEC Accession Number: 17065513, DOI: 10.1109/ICC.2017.7997213, Publisher: IEEE.
- [7] L. Manjunath, N. Prabhakaran. Interference Management, Backhaul Routing & Switching off in 5G Hetnets with Mmwave Backhaul Links: A Relative Perspective, *International Journal of Innovative Technology and Exploring Engineering (IJITEE)* ISSN: 2278-3075, Volume-9 Issue-6, April 2020, Page(s): 421-426, Publisher: IEEE.
- [8] Zeinab A. aboelezz, Hala B. Nafea, and Fayez W. Zakil, Handover and QoS Control in LTE HetNet Based on Fuzzy Logic Design, Published in: 2019 7th International Japan-Africa Conference on Electronics, Communications, and Computations, (JAC-ECC), Date of Conference: 15-16 Dec. 2019, DOI: 10.1109/JAC-ECC48896.2019.9051126, Page(s): 178-183, Publisher: IEEE.
- [9] Muhammad Usman Iqbal, Ejaz Ahmad Ansari, and Saleem Akhtar, Interference Mitigation in HetNets to Improve the QoS Using Q-Learning, *IEEE Access* (Volume: 9) Date of Publication: 19 February 2021, DOI: 10.1109/ACCESS.2021.3060480, Page(s): 32405 – 32424, Publisher: IEEE.
- [10] Zeeshan Kaleem, Bing Hui and KyungHi Chang, QoS priority-based dynamic frequency band allocation algorithm for load balancing and interference avoidance in 3GPP LTE HetNet. Kaleem et al, *EURASIP Journal on Wireless Communications and Networking* 2014 2014:185, DOI: 10.1186/1687-1499-2014-185.
- [11] Waleed AlSobhi, and A. Hamid Aghvami, QoS-Aware Resource Allocation of Two-tier HetNet: A Q-learning Approach, 2019 26th International Conference on Telecommunications (ICT) Page(s): 330-334, Date of Conference: 8-10 April 2019, Date Added to IEEE Xplore: 15 August 2019, INSPEC Accession Number: 18922699, DOI: 10.1109/ICT.2019.8798829, Publisher: IEEE.
- [12] Jihene Ben Abderrazak, Amina Zemzem and Hichem Besbes, QoS-Driven User Association for Load Balancing and Interference Management in HetNets, 2015 6th International Conference on the Network of the Future (NOF), Date of Conference: 30 Sept.-2 Oct 2015, Date Added to IEEE Xplore: 23 November 2015, INSPEC Accession Number: 15604453, DOI: 10.1109/NOF.2015.7333280, Publisher: IEEE.
- [13] Ying Loong Lee, Teong Chee Chuah, Ayman A. El-Saleh, and Jonathan Loo, User Association for Backhaul Load Balancing with Quality-of-Service Provisioning for Heterogeneous Networks, *IEEE Communications Letters* (Volume: 22, Issue: 11, Nov. 2018), Date of Publication: 27 August 2018, INSPEC Accession Number: 18246219, DOI: 10.1109/LCOMM.2018.2867181, Page(s): 2338 – 2341, Publisher: IEEE.

# A Contemporary Survey on Low Power, High Speed Comparators for Bio-Medical Applications

R. Rajalakshmi<sup>a,1</sup>, Dr.M.Janaki Rani<sup>b</sup> and Dr.M.Anand<sup>c</sup>

<sup>a</sup> *Research Scholar, Dept of ECE, Dr.M.G. R Educational & Research Institute University, Chennai-95*

<sup>b, c</sup> *Professor, Dept of ECE, Dr.M.G.R Educational & Research Institute University, Chennai-95*

**Abstract.** The analysis of biomedical signals performs an important role in figuring out numerous issues in clinical science. Also, the urge to track biomedical signals in fitness and well-being control is progressively growing with the multiplied occurrence of persistent sicknesses over the last decade. By nature, the most of the real-time signals are analog. Hence, an Analog to digital converter (ADC) is required to transform the signal. In ADC architecture, the comparator is the essential block that performs a vital role and consumes greater power in ADC design. Numerous architectures for comparators relate to biomedical programs are mentioned in recent days. In this paper, the exceptional latest techniques of comparator designs are discussed with their key capabilities in conjunction with pros and cons.

**Keywords.** Low power and high-speed comparators, Latch, preamplifier, DC, offset voltage, dynamic power.

## 1. Introduction

Implantable medical devices (IMD) are commonly battery-operated and fairly energy-constrained. Replacing an implant is not advisable for the reason that surgical treatment is risky and high-priced too. The importance of battery-operated devices with less weight, small size, and low power paves to design ultra-low-power ADCs. During a previous couple of years, diverse strategies were delivered to help the reduction in supply voltage and power dissipation in Bio signal processing systems. The continued scaling of feature size is often essential to improving the battery life of the medical implant device. There are 3 major demanding situations influence low voltage operation: 1. In submicron technology, the device parameters such as feature size together with the length of the channel (L), the thickness of gate oxide (tox) are continued to scale down which results in reduced supply voltage to make certain device

---

<sup>1</sup> R.Rajalakshmi, Research Scholar, Dept of ECE, Dr.M.G.R Educational & Research Institute University, Email: rajeeeranathan@gmail.com

reliability. 2. Due to growing the variety of additives on a single Si chip dissipates a quantity of power according to unit area results in over-heating. Overheating of a chip is avoided only by less density in order that the power of the digital circuit desires is restricted. 3. The next challenge is associated with the battery-powered system. Due to portability and to have proper functionality, the supply voltage, and supply power need to be decreased [14]. The energy consumption of comparators has an enormous impact on the whole energy intake of the device. Hence, the design of low power and high-speed comparator is needed to perform the necessity of responsibility. Fundamental blocks present in SAR ADC are depicted below [5]:

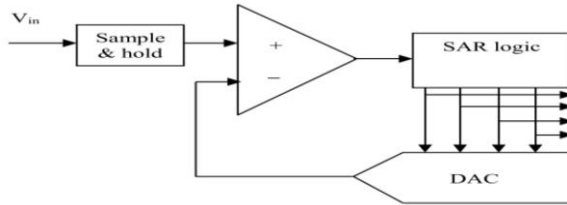


Figure 1. SAR ADC architecture

SAR ADC is one of the most suitable candidates for bio signal process applications among all [13]. It includes Sample and Hold Circuit, Comparator, SAR Logic, and DAC Module. The Comparator is the one, consumed up more power nearly 70% within the complete architecture. Hence, optimizing the overall performance of the comparator on the premise of its figure of merit is relatively important.

## 2. Literature Review

Comparator is a vital part of Analog to Digital Converters (ADC) within the mixed-mode signal designs. Numerous Researches are illustrated with different circuits and strategies to improve the performance of comparators. The dynamic comparator has high input impedance, negligible static power consumption, rail-to-rail output swing, precise noise, and mismatch robustness, consequently, it's far pretty distinguished for SAR ADC in Ref. [1]. Kasi Bandla, et.al, has reviewed that static power consumption is excessive in Dynamic Latch Comparator with Pre-Amplifier topology and consequently no longer most suitable for low power applications. However, the above-mentioned topology is ideal for correct evaluation the Charge Sharing Dynamic Latch Comparator (CSDLC) is used in order to have low energy. Also found that it fails to offer rail-rail output swing in each of the clock cycles. They additionally observed; the one another topology called Strong-Arm Dynamic Latch based comparator (SADLC) is used to clear up the troubles. They highlighted its overall performance with other different comparator topologies in Ref. [2].

As another example, in Ref. [3] mentioned by G. Murali Krishna et.al, has reviewed the design of dynamic comparators, in comparison with traditional comparators and Double tail comparators. They proposed a design that includes a P-MOS latch which ensures predictable delay throughout an evaluation segment. Another segment reset is similar to a traditional comparator. The above-stated topology is controlled via way of means of a unique clock signal designed cautiously to consumes much less power. They also added that the speed of the comparator will increase the use of input NMOS transistors.

Parvin Bahmanyar et.al, in Ref. [11] has discussed the performance of a double-tail latched comparator designed for ultra-low-energy applications. This method is well-perfect for Low supply voltages among four hundred mV to one V and also self-neutralization and reduction in kickback noise are key features of this technique. In general, the proposed circuit achieves a good figure of merit, the results are in comparison with a traditional double-tail latched comparator. In this method, large gain amplifiers are used to attain the proper resolution due to this bandwidth of the Amplifier has got reduced consequently affects the gain bandwidth trade-off.

The comparator mentioned in Ref. [6] has mentioned the design within the sub threshold region to have a very low energy intake that's appropriate for SAR ADC. They also noted that an adjustable calibration capacitor array is used in the design to cancel the charge error caused by parasitic capacitors. The proposed comparator may be operated at a supply voltage of 0.75 V and an overall energy intake of 250 nW received as a result. It is proven in Ref. [7] The low-offset dynamic comparator is another promising design proposed for low-power applications. It ensures good performance in the aspect of lesser power and offset voltage. An approach mentioned right here is to use the tail transistor with careful sizing which ends up reducing the energy intake in dynamic comparators in Ref. [7].

As discussed in ref. [8], the proposed comparator and controller are more suitable for Implantable Medical Devices. The method proposed in Ref. [9], High-speed dynamic analog comparator that gives low offset and no longer requires any preamplifier. A four-input dynamic comparator is mentioned by Chi-Chang Lu and Ding-Ke Huang in Ref. [4]. In this method, the twin sampling process is used throughout the sampling segment because the applied input signals are multiplied by factor two for every instance. As another example in Ref. [5] Ahmed Naguib et.al, have developed a model precise for Energy-Efficient Biomedical SAR ADCs and mentioned static energy lifestyles throughout the amplification segment.

### 3. Comparator Topologies

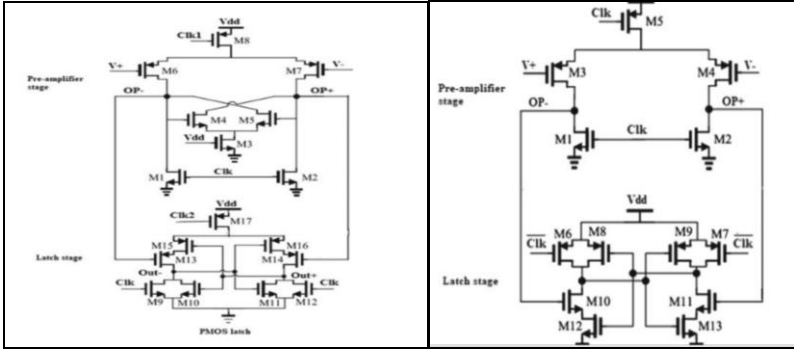
This section deals with the prevailing few comparator architectures that have been mentioned within the literature overview. In this paper, we also speak the merits and demerits of each mentioned comparator topology with respect to their figure of merits.

#### 3.1. Comparators

They are referred to as 1-bit converters and commonly used in analog to digital converter. In the A/DD D conversion process, the analog input to be sampled at the earliest then applied to an aggregate of comparators to decide its digital value. In preferred, Comparator consists of the preamplifier level, latch, and output amplifier called Buffer. The preamplifier is needed to acquire sufficient gain on the way to save the input offset voltage of the dynamic latch. The usage of a separate preamplifier does not find in some ADC designs due to the fact that the CMOS latch itself performs the amplification. The latch/ selection module is one of the essential blocks it needs to be capable of discriminating mV range signals. It's formed by an input differential pair that imbalances a pair of crossed-coupled inverters, growing wonderful remarks that boost the outputs to the rails which result in proper decision [10]. The very last thing

inside the comparator layout is an output buffer or post-amplifier that helps to transform the decision output into a logical signal (i.e., 0 or 1 V).

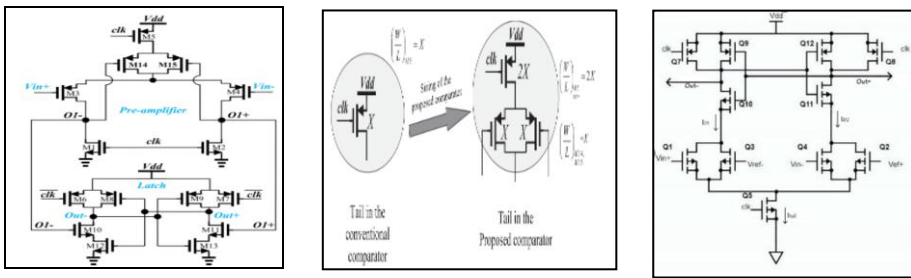
### 3.1.1 Conventional Comparator



**Figure 2.** Conventional dynamic Comparator **Figure 3.** PMOS Latch Comparator

This comparator is constructed with the useful resource of a pre-amplifier and latch. It has stages of operation named, reset, and evaluation phase. In the conventional circuit, large parasitic capacitors are created at nodes during the course of an evaluation phase, which observes high energy consumption, and a larger time is needed to finish the whole process. P-MOS latch comparator has proposed to solve all the mentioned issues. It produces predictable delay within the course of the evaluation stage whereas the delay was unpredictable and uncontrollable within the conventional comparator. The reset segment is similar to a conventional comparator. The proposed topology is controlled with the aid of a unique clock signal generated cautiously. In the P-MOS latch, the size/dimension of M4, M5 transistors needs to be taken care of to enhance the differential gain.

### 3.1.2 Low-power dynamic comparator



**Figure 4.** Low Power dynamic Comparator **Figure 5.** Tail transistor sizing **Figure 6.** Strong Arm dynamic latch

In this approach, tail transistors (M14, M15) are small in size added with traditional low offset dynamic comparator to improve the performance, as an end result, energy overhead is significantly negligible (less than 10%). Due to the tail current, the output



swings completely to reach the full-scale value near  $V_{dd}-|V_{thp}|$ , which reduces leakage power.

### 3.1.3 Strong-arm dynamic latch comparator

As static power dissipation is immoderate in Dynamic Latch Comparator consequently not suitable for low power applications. The method illustrated here in Fig.6. used two clocked nMOS tail-transistors and in preference with transistors Q1, Q2, Q3, and Q4 are re-arranged in comparison with dynamic latch, this method helps to resolve static power leakage and enhances other figures of merit.

**Table 1.** Comparisons of different Topologies for Bio Medical Applications

Topology used	Avg Power consumption	Offset voltage	Frequency	$V_{dd}(V)$	Area ( $\mu m^2$ )	Speed @ $V_{cm}$ 0.9 V	Technology
Conventional Comparator	556 $\mu W$	2.65 mV	0.5 GHz	1.8 V	343 $\mu m^2$	1.16 GHz	0.18 $\mu m$
Tailed Comparator with Transistor Sizing [7]	347 $\mu W$	2.19 mV	0.5 GHz	1.8 V	361 $\mu m^2$	1.05 GHz	0.18 $\mu m$
Relative Observation	+37.6%	+15.8%			-5%	-9.5%	

Topology used	Total Average Power ( $\mu W$ )	Operating Frequency	Supply Voltage (V)	Maximum power ( $\mu W$ )	Delay	Technology
Conventional Comparator	1.87	0.5 GHz	5	154	350 pS	250 nm
Double Tailed Comparator	3.78	0.5 GHz	5	122	500 pS	250 nm
PMOS Latch comparator	1.25	0.5 GHz	5	115	250 pS	250 nm

Topology used	Average Dynamic Power ( $\mu W$ )	Offset voltage in (mv)	Supply Voltage (V)	Clock-Feed-through	Kick Back Noise	Average Delay in (ps)	PDP (fJ)	Technology
CSDLDC	18.0	63	1.8	0.04	0.216	178.1	3.2	0.18 $\mu m$
SADLC	4.82	6	1.8	0.059	0.182	92.75	0.44	0.18 $\mu m$
Strong Arm Dynamic Comparator	4.72	6	1.8	0.06	0.184	93.4	0.44	0.18 $\mu m$

## 4. Conclusion

Bio physiological signals are low voltage and low-frequency signals. Hence, analysis requires a converter with low noise and low power operations which helps to extend

the lifetime of the battery-powered bio-implants. In this aspect, various types of dynamic comparators have been discussed and shown in Table 1. From the above table, we found that the performance of the comparators differs with respect to design methodology primarily supply voltage and simulation type. The authors also observed that the double tail comparator with proper transistor sizing, Strong Arm Dynamic Comparator, and ultra-double-tail latched comparator operated within the voltage swing between 0 to 2 V are suitable for SAR ADC on Biomedical applications. We have planned to adopt hybrid adiabatic energy optimizing logic to implement a double-tail latched comparator since there is a lot of scopes available for further energy optimization.

## References

- [1] Polineni.S, M. S. Bhat, and S. Rekha, A Switched Capacitor-Based SAR ADC Employing a Passive Reference Charge Sharing and Charge Accumulation Technique, *Circuits, Syst. Signal Process.*, vol. 39, no. 11, pp. 5352–5370, 2020, doi: 10.1007/s00034-020-01437-3.
- [2] Bandla.K, A. Harikrishnan, and D. Pal, Efficient Dynamic-Latch Comparator for SAR-ADC, pp. 299–302.
- [3] Murali Krishna.G, Karthick.G, and Umapathi.N, Design of Dynamic Comparator for Low-Power and High-Speed Applications, vol. 698. Springer Singapore, 2021.
- [4] C. C. Lu and D. K. Huang, A 10-Bits 50-MS/s SAR ADC Based on Area-Efficient and Low-Energy Switching Scheme, *IEEE Access*, vol. 8, pp. 28257–28266, 2020, doi: 10.1109/ACCESS.2020.2971665.
- [5] Naguib.A .High Speed and Low Power Comparator in 65 nm CMOS for Energy Efficient Biomedical SAR ADCs. 2020 12th Int. Conf. Electr. Eng. ICEENG 2020, pp. 339–342, 2020, doi: 10.1109/ICEENG45378.2020.9171729.
- [6] M. Sadollahi and G. Temes, An 11-bit 250-nW 10-kS/s SAR ADC with doubled input range for biomedical applications, *Midwest Symp. Circuits Syst.*, vol. 2017-Augus, pp. 385–388, 2017, doi: 10.1109/MWSCAS.2017.8052941.
- [7] Khorami.A, Saeidi.R, Sachdev.M, and M. Sharifkhani, A low-power dynamic comparator for low-offset applications, *Integration*, vol. 69, no. February, pp. 23–30, 2019, doi: 10.1016/j.vlsi.2019.07.001.
- [8] K. Noh, J. Amanor-Boadu, M. Zhang, and E. Sanchez-Sinencio, A 13.56-MHz CMOS Active Rectifier with a Voltage Mode Switched-Offset Comparator for Implantable Medical Devices, *IEEE Trans. Very Large Scale Integr. Syst.*, vol. 26, no. 10, pp. 2050–2060, 2018, doi: 10.1109/TVLSI.2018.2845369.
- [9] Kiran.B and V. A. Meshram, Design and Analysis of a High Speed CMOS 12-bit 400-MSample / s using Switched Capacitive Flip around Technique for Pipeline ADC, vol. 29, no. 7, pp. 13238–13248, 2020.
- [10] Donadkar.D.N and S. U. Bhandari, Review on comparator design for high speed ADCs, *Proc. - 1st Int. Conf. Comput. Commun. Control Autom. ICCUBEA 2015*, pp. 974–978, 2015, doi: 10.1109/ICCUBEA.2015.206.
- [11] Bahmanyar.P, M. Maymandi-Nejad, S. Hosseini-Khayat, and M. Berekovic, Design and analysis of an ultra-low-power double-tail latched comparator for biomedical applications, *Analog Integr. Circuits Signal Process.*, vol. 86, no. 2, pp. 159–169, 2016, doi: 10.1007/s10470-015-0632-x.
- [12] Rodriguez-Prez.A, Delgado-Restituto.M, and Medeiro.F., Power Efficient ADCs for Biomedical Signal Acquisition. *Biomed. Eng. Trends Electron. Commun. Softw.*, no. January, 2011, doi: 10.5772/13070.
- [13] V. P. Singh, G. K. Sharma, and A. Shukla, Power efficient SAR ADC designed in 90 nm CMOS technology, 2nd Int. Conf. Telecommun. Networks, TEL-NET 2017, vol. 2018-Janua, pp. 1–5, 2018, doi: 10.1109/TEL-NET.2017.8343542.
- [14] Meerajahana.V, Vedhanayagi.P, and Ramasamy.K. Design of Low power Successive Approximation Register ADC Using 14 bit Two-Split Capacitor DAC Array .no. 8, pp. 270–275, 2016.

# 5G Wireless/Wired Convergence of UPMC Based Modulation for Intensity Modulation Direct Detection

Keerthivasan K<sup>a,1</sup>, Shibu S<sup>b</sup>

<sup>a</sup>PG Scholar, Dept of ECE, Panimalar Engineering College, Chennai, India

<sup>b</sup>Assistant Professor, Dept of ECE, Panimalar Engineering College, Chennai, India

**Abstract:** Faster data speeds, shorter end-to-end latencies, improved end-user service efficiency, and a wider range of multi-media applications are expected with the new 5G wireless services. The dramatic increase in the number of base stations required to meet these criteria, which undermines the low-cost constraints imposed by operators, demonstrates the need for a paradigm shift in modern network architecture. Alternative formats will be required for next-generation architectures, where simplicity is the primary goal. The number of connections is expected to increase rapidly, breaking the inherent complexity of traditional coherent solutions and lowering the resulting cost percentage. A novel implementation model is used to migrate complex-nature modulation structures in a highly efficient and cost-effective manner. Theoretical work to analyse modulations' behavior over a wired/fiber setup and wireless mode is also provided. The state-of-the-art computational complexity, simplicity, and ease of execution while maintaining efficiency throughput and bit error rate.

**Keywords:** 4G, 5G, OFDM, Modulation, UPMC, Intensity Modulation Direct Detection.

## 1. Introduction

As the research community focuses on the next generation requirements of high data rate, low latency, low energy consumption, high scalability, improved connectivity, reliability, and higher security, it will become clearer how future architectures will need to be designed to meet these challenges. A key factor for mobile operators is the rapid increase in mobile applications that require low network latency, which has resulted in a market shift. To reduce network latency, all telecommunications equipment vendors now have plans to evolve their network technologies. This latency is caused by the wireless in which communication link's unreal ability due to time-varying channel fading and multiple propagation paths. The key to achieving low latency at the physical layer is to use the right technologies to overcome wireless channels' limitations. Synchronization, channel coding, interleaving,

<sup>1</sup>Keerthivasan K, PG Scholar, Dept of ECE, Panimalar Engineering College, Chennai, India, Email:keerthivasan.k21@gmail.com

demodulation, channel estimation, multiple input, multiple output detection, and other techniques are used in baseband systems. Many redundancies are introduced when channel estimation is used in a multi-antenna receiver system.

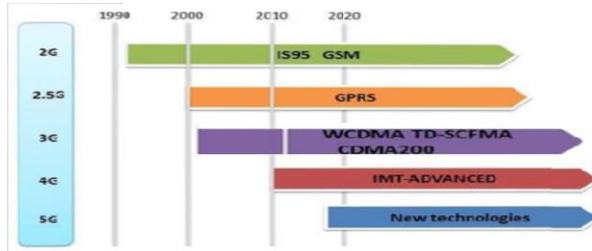


Figure 1. Evolution of mobile networks

Orthogonal Frequency Division is a technique for dividing frequencies that are orthogonal to Although the multiplexing technique has established itself as the dominant modulation scheme in the fourth generation of broadband systems, some of its shortcomings have prompted the research community to consider other possible alternatives that could improve overall performance in the next generation [5-6].

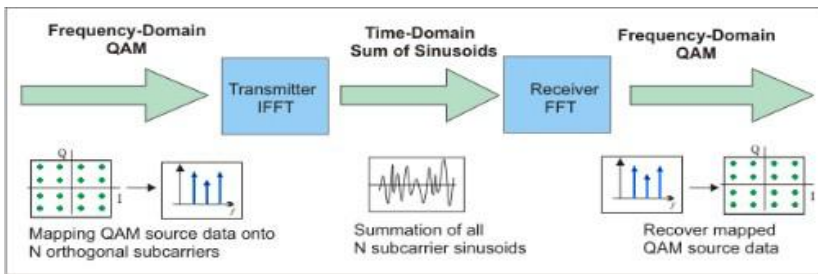


Figure 2. OFDM General blocks

Inter-carrier interference should be avoided by spacing the sub-carriers evenly. Figure 2 depicts an OFDM multicarrier modulation model. One method is to keep them apart by stationing ominous guard bands among them. We'll focus on three of them in this paper because they've gotten a lot of attention recently: Filter Bank Multi-Carrier (FBMC), Universal-Filtered Multi-Carrier (UFMC), and Generalized Frequency Division Multiplexing are all examples of frequency division multiplexing (GFD). All of them have arisen to address some of the shortcomings of OFDM, and it is this fact, as well as the properties that follow it, that will make them suitable for specific applications.

## 2. Proposed Method

### 2.1 Signal carrier

Signal carrier waveforms have a lower peak-to-average power ratio, resulting in increased power amplifier efficiency and battery life. Furthermore, the amplifier is required in the presence of a multipath to achieve high spectral efficiency. Single carrier quadrature amplitude modulation, single-carrier frequency-domain equalization,

single-carrier frequency division multiplexing, and zero-tail SC-FDM are all examples of single-carrier quadrature amplitude modulation.

### 2.2 Multi-Carrier

Within a given bandwidth, multicarrier OFDM-based waveforms support orthogonal sub- carriers. Furthermore, waveforms based on multicarrier OFDM are easily integrated with MIMO, resulting in high spectral efficiency. The following are examples of multicarrier waveforms: cyclic prefix OFDM, CP-OFDM with four weighted overlaps, universal-filtered multicarrier, filter bank multicarrier generalized frequency division multiplexing CP-OFDM is efficient because it employs the fast inverse Fourier transform in both the transmitter and receiver.

### 2.3 Mm-Wave

The mm-wave band provides 5G systems with a Gigahertz amount of bandwidth. The following are some of the ramifications of using the mm-wave spectrum. The ability to share the spectrum with satellite or radar systems using cognitive radio techniques. It is possible to generate very narrow beams with smaller directional and adaptive antenna arrays because of the small wavelength. Mm-wave can deliver gigabit-per-second peak, average, and outage rates required in various 5G scenarios.

### 2.4 Massive MIMO

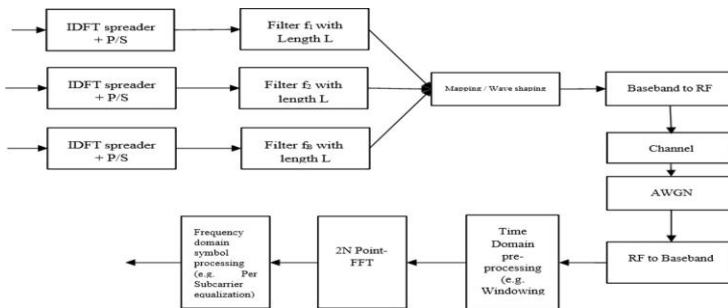


Figure 4. Proposed Method

All negative subcarrier records in the primary preparing image have invalid tones, and all positive subcarrier records in the subsequent image have invalid tones. To characterize our UPMC system, consider a simple one-to-one transmission. The total N subcarriers are divided into B sub-bands. It is worth mentioning that if the order of the filter  $L=1$ , UPMC converges to ZP-OFDM. Figure 4 shows that the block diagram at the Transmitter and Receiver. By simulating a simple point-to-point UPMC transceiver, we will see the spectrum of a UPMC signal. Our transmission parameters will be the same as they were in the case of OFDM and f-OFDM. Below table 1 lists all the parameters that were used.

**Table 1.** Simulation Parameters UFMC transceiver

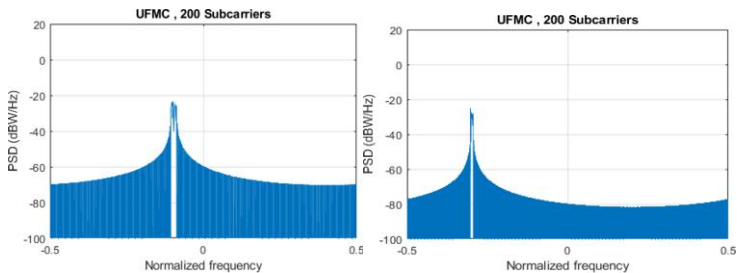
Parameter	Wired/Wireless standard
FFT/IFFT size	1024
Number of used data subcarriers	360
Number of pilot subcarriers	12
Number of guard bands	32
Zero Padding	1/8
Channel Bandwidth (MHz)	5
Modulation	QAM

### 3. Results and Discussion

Based on the simulation results, the proposed method offers more significant improvements. The coverage areas of femto cells may overlap in a deployment where a certain number of femto cells are deployed. Data is transferred orthogonally to each node in this network. Table 2 shows the summary of the existing and proposed methods. It demonstrates that quadrature amplitude modulation can be used to estimate network path loss.

**Table 2.** Summary

Description	Existing	Proposed
Modulation factor	PAM	QAM
PAPR	5.4396 [8]	4.516



**Figure 5.** UFMC subcarriers for FFT size 512 (Left) and FFT size 1024 (Right)

The reduction in the power density of an electromagnetic wave propagates through space, known as path loss or path attenuation. Path loss is an important factor to consider when distances shows that path loss leads to increases in SNR. Free-space loss, refraction, diffraction, reflection, aperture-medium coupling loss, and absorption

are all path loss examples using wireless cellular networks to their full potential. Figure 5 shows the UPMC subcarriers for FFT size 512 (Left) and FFT size 1024 (Right). It means that as the likelihood of detection rises, the likelihood of a false alarm decreases. The size of the FFT is 1024 bytes, and the number of subcarriers is two. For each modulation technique (16 QAM and 64 QAM), values are taken. The 64 QAM modulation technique yields the best results. The size of the FFT is 512 bytes, and the number of subcarriers is two. For each modulation technique (16 QAM and 64 QAM), values are taken. The 64 QAM modulation technique yields the best results.

#### 4. Conclusion

Amplitude Modulation-Direct Detection Optical Front Hauling has been proposed to solve the next generation of 5G cellular networks. The various waveform candidates from wireless radio access networks have been directly converted to fiber front hauls and tested. State-of-the-art computational sophistication and performance while retaining the critical low out-of-band radiation and high data speeds of each new modulation in greater scalability and lower cost. The evaluating OFDM-based modulation schemes for future wireless communication. UPMC was one of the modulation schemes we considered. We evaluated the performance of each modulation scheme in both synchronous and asynchronous modes.

#### References

- [1] Sarmiento Hernández, S., 2020. Design and optimization of metro-access networks supporting 5g services.
- [2] Dahawi, T.H., Yusoff, Z., Salleh, M.S. and Senior, J.M., 2021. Low-cost MIMO-RoF- PON architecture for next-generation integrated wired and wireless access networks. *Journal of Optical Communications and Networking*, 13(3), pp.41-52.
- [3] Elmagzoub, M.A., Shaikh, A., Alghamdi, A. and Rajab, K., 2020. A Review on MIMO Wireless Signals over Fibre for Next Generation Fibre Wireless (FiWi) Broadband Networks. *Electronics*, 9(12), p.2014.
- [4] Karembera, R., Nfanyana, K. and Gibbon, T., 2021. Simultaneous transmission of clock and data signals in photonic-assisted WDM passive optical networks. *JOSA B*, 38(3), pp.914-921.
- [5] Dayana, R., Malarvezhi, P., Vadivukkarasi, K. and Kumar, R., 2020. UPMC-IOTA Based Cognitive Radio Transceiver. *Wireless Personal Communications*, 114, pp.2105-2119.
- [6] Nagarajan, N.R. and Maheswari, M., 2020, December. A survey on UPMC filter designs for 5G M2M. In *Journal of Physics: Conference Series* (Vol. 1706, No. 1, p. 012158). IOP Publishing.
- [7] Zhang, X., Wang, X. and Chen, Z., 2018, May. A transceiver modification for a universal filtered multicarrier scheme in a 5G cellular network. In *2018 IEEE International Conference on Communications (ICC)* (pp. 1-6). IEEE.
- [8] Kishore, K.K., Umar, P.R. and Naveen, V.J., 2017. Comprehensive analysis of UPMC with OFDM and FBMC. *Indian Journal of Science and Technology*, 10(17), pp.1-7
- [9] Thiyagarajan, S. and Veerappan, S., Performance Analysis of UPMC and its Comparison with CP-OFDM.
- [10] Salah, S., Selem, M., Seleem, H. and Ali, M.A., 2020. Reduced OoB Emission and PAPR Using Partial-OSLM technique in 5G UPMC Systems. *Journal of Engineering Research*, 4(December), pp.1-6.
- [11] Keerthivasan K, and Shibu S .Survey on Mobile Edge Computing for the Internet of Things System .(doi:10.3233/APC200191)

# Study of Microstrip Dual-Band Band Pass Filter

Anciline V <sup>a,1</sup>, and Maheswari S <sup>b</sup>

<sup>a</sup>PG Scholar, Dept of ECE, Panimalar Engineering College, Chennai

<sup>b</sup>Professor, Dept of ECE, Panimalar Engineering College, Chennai

**Abstract.** The main component widely used in wireless communication system is dual-band band pass filter. This band pass filter is intended in many ways and some are microstrip, waveguide, etc. The dual-band will works in two different frequency ranges which will provide a huge application. This paper compares different microstrip dual-band band pass filter based on the techniques, insertion loss, frequency, etc.,

**Keywords.** Microstrip, Dual-band band pass filter, Stepped-Impedance resonator.

## 1. Introduction

Microstrip dual-band band pass filters have many advantages like low insertion loss, wide stop band bandwidth, compactness, sharp roll-off, and it has a large application in microwave communication. The most effective way for connecting two BPFs with different pass bands in parallel [4]. Microstrip is a category of electrical transmission line, with the help of this technology microstrip might be manufacture, where the conductor was segregated from a ground plane by a dielectric layer. The dielectric layer is known as substrate. To transfer microwave frequency signals microstrip-lines are employed. The microwave elements such as antennas, power dividers, filters, couplers, and so on, might be set-up from microstrip, with the appearance tool available as the model of metallization over the substrate. The main advantage of microstrip is less exorbitant than the conventional waveguide technology, compactness and far lighter. The band pass filter might be made by cascade the high pass filter to the low pass filter, or antipodal. The main purpose of such filter is to restrain the bandwidth of the output signal to the band allotted for the communication. The key component, for recognition of a dual-band wireless communication system is dual-band band pass filter [3]. At first dual-band filter report, the two separate filters which are straightly cascaded with two specified pass bands. But in this case, we got a large overall size and high insertion loss in its filter block [1].

---

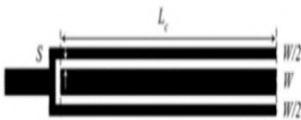
<sup>1</sup>Anciline V, PG scholar, Dept of ECE, Panimalar Engineering College, Chennai;  
E-mail: ancilinevargees741@gmail.com



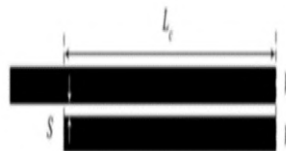
## 2. Related works

Sheng Sun et.al [1] In this work they focused on, compact dual-band microstrip bandpass filter, without any exterior impedance matching block, works at 2.4 and 5.2 GHz with FBW of 7.0% and 4.0%. Modified  $\lambda/2$  stepped impedance resonator along the bending arrangement was set-up for simultaneous execution of double resonance at these two prescribed frequencies thereby keeps down the full extent  $10.2 \times 12.3 \text{mm}^2$ . To keep down the return losses under twain dual pass band, the collateral open-strip line is correctly characterized. The enhanced results, express acceptable dual-band filtering execution with return loss exceeding 20dB while the assessed insertion losses were 1.8dB as well as 2.9dB by using WK-3000 substrate.

Yue Ping et.al [2] In this paper they fully focused on, by using SIR, a microstrip BPF was intended in low-temperature co-fired ceramic technology in order to dual-band implementation upon two prescribe frequencies 2.4GHz and 5.2GHz. The paradigm of the bandpass filter reached the insertion loss of 0.42dB as well as 0.91dB, return loss of -29 as well as -40dB likewise bandwidth of 14.2% as well as 12%. The bandpass filter is additionally measured for a unique package clarification of dual-band radio transmitter and receiver.



**Figure 1a.** Coupling scheme novel

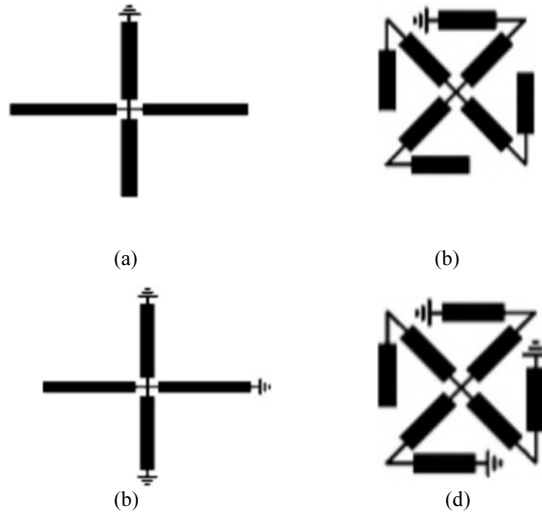


**Figure 1b.** Coupling scheme normal

Chao-Hsing et.al [3] By using net-type resonators, a fresh dual-band microstrip BPF is evolved at frequencies  $f_1=1\text{GHz}$  moreover  $f_2=2\text{GHz}$ . The trial basis demonstrated by using the RO4003 substrate. The measured result of the improved filter is an acceptable execution with the reproduced result via full-wave electromagnetic simulator. With return loss more than somewhat 12.6dB, also insertion loss of 2.65/2.44dB with FBW is 4.6/4.8%. The quality factor is 20.7/19.6 for the intended filter with the size of  $41.83 \times 31.73 \text{mm}^2$ .

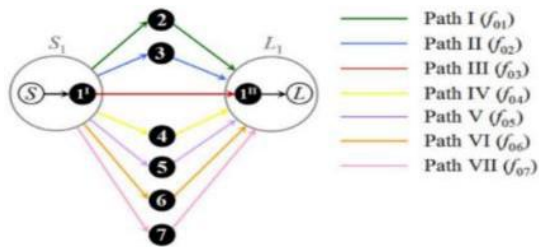
Runqi Zhang et.al [4] are suggested a compress dual-band BPF, by using coupled three-portion stepped-impedance resonators, with the frequency 0.61GHz and 1.36GHz. To get the input admittance, the even-odd mode scrutiny way was utilized. To analysis the filtering execution also the exactness of the submitted scheme principle, prototype dual-band filter turned out to be intended and fabricated. The resulted insertion loss is 0.45/0.75dB with FBW of 32.3/10.5% with the transmission line theory technique.

B.A. Belyaev et.al [5] This paper is mainly focused on the quality factor. Based on interdigital structure, a novel compact microstrip resonator is suggested. The quality factor of the resonator has many times outnumbering the same resonators which are already present. By enlarging the count of pins in the interdigital arrangement, the dimension of the resonator might be decreased with notable surge in quality factor. On the base of suggested structure, a bandpass filter of 4-pole with size  $4.6 \text{mm} \times 10.0 \text{mm}$  and a central frequency 900MHz was intended and fabricated, with the return loss of -13dB and insertion loss of 1.7dB with FBW of 20%. The unloaded quality factor is 120 for this design.



**Figure 2.** (a) and (c) Cross resonators, (b) and (d) Net-type resonator.

Chi-Feng Chen et.al [6] This paper focused on, a size reduced sept-band bandpass filter over elastic passband sharing were suggested with frequencies are 1.05/1.3/1.5/2.05/2.35/2.85GHz. Whole passbands might be completely controlled and drawn autonomously, by initiating multiple coupling paths. The initial and final resonators were utilized to generate other passbands and as well serve as the input as well as output paring structure for the other passbands. So, extra functioning bands might be acquired without expanding the circuit area. The exceptional arrangement of resonator might assist to decrease filter space of  $0.027\lambda_g^2$  as well as produce extra functioning bands with FBW of 8/4/5/7.5/4.5/5.5/6.5% with the help of Agilent N5230A.



**Figure 3.** Coupling structure of sept-band bandpass filter.

Chuantao Cai et.al [7] This paper is focused on, a new design version of microstrip wideband balun bandpass filter is suggested over frequency 1GHz. The antiphase signals might be purchased at two output ports of a balun, via utilizing standing-wave attribute

of voltage distribution beside an open circuited  $\lambda/2$  microstrip transmission line. To obtain a balun bandpass filter with two characteristics of balance execution and wideband filtering properties, by proper paring topologies amid the open circuited half wavelength microstrip transmission line, also the multi-manner resonators are selected. A balun bandpass working at 1GHz with an 30% of FBW was intended, executed also evaluated. Twain the measured as well as simulation outcome of intended balun bandpass filter are gives with acceptable assents of return loss better than 19dB and insertion loss of 0.8dB with the size of  $0.586 \times 0.317 \lambda_g^2$ . This balun band pass filter exhibits not only a high selectivity filtering performance with two common TZs of  $S_{21}$  and  $S_{31}$  external passbands, but also an acceptable balance performance over 0.5dB amplitude instability also 5° phase instability, by using the Rogers RO4003C substrate.

Roberto Gomez-Garcia et.al [8] with the help of Agilent E8361A, a regular quasi-reflection less dissimilarity mode bearing was suggested for microwave planar steadied single/dual-band BPF at frequency 2.82MHz and 3.21MHz. Two proof-of-principle microstrip prototypes containing of 3GHz second order single band and 2.85/3.15GHz 1<sup>st</sup> order dual-band bandpass filter with insertion loss 1.9/1.7dB with FBW of 5.2/5.1% have been improved and simulated.

Xiaohu Wu et.ai [9] This paper is the first to do manifestation of broadcast as well as consistent all band quasi-absorptive filters that might be intended to haphazardly high order with help of Rogers 4003C substrate and the frequency is 2.2GHz and 2.76GHz. The suggested quasi-absorptive filter contains of an absorptive sections and bandpass sections. In additional to eliminate the out-of-band reflection, the adsorptive sections determine the passband bandwidth. In additional to determine the out-of-band roll-off, bandpass section determine the order of the filter might be haphazardly enhanced do not have disturbing the filter bandwidth through cascading extra bandpass sections. A group of 2.45GHz one, two, trio pole quasi-absorptive microstrip bandpass filter are intended also evaluated. Across the passband and the stop band, the filter shows simultaneous input and output absorption. Measurement results are giving the acceptable difference over the simulation and authenticate the suggested purpose with insertion loss of 1.1dB and FBW of 22.8%.

Gen-Zhu Liang et.al [10] In accordance with loaded open/short-circuited stubs, a dual-wideband bandpass filter is suggested and analyzed with the Zeland IE3D and Agilent 5230A. The dual-band filter contains 2<sup>nd</sup> order bandpass filter and the 3<sup>rd</sup> order bandpass filter, any one that might be intended one by one. The bandwidth of two passband might be amended by regulate the impedance and the length of the stubs. A dual-band bandpass filter prototype works at 2.4/5.2GHz was intended proof with size  $0.28 \times 0.20 \lambda_g^2$ . It has 0.3/0.7dB insertion loss and blanket bandwidth of 51.9% (2.4GHz) as well as 23.3% (5.2GHz) and return loss is 22.1/20.8dB. In the absence of contract paring gap amid resonators, the filter structure was effortless to fabricate.

### 3. Literature survey

**Table 1.** Comparison of different microstrip dual-band Band pass Filters

S. No	Technology	Insertion Loss dB	Size	Frequency	FBW%
[1]	Modified $\lambda/2$ SIR	1.8/2.9	$10.2 \times 12.3 \text{mm}^2$	2.4/5.2GHz	7.0/4.0
[2]	Single-layer LTCC	0.42/0.91	-	2.4/5.2GHz	14.2/12

[3]	Net-type resonator	2.65/2.44	41.83×31.73mm <sup>2</sup>	1/2GHz	4.6/4.8
[4]	Coupled 3-section SIR	0.45/0.75	-	0.61/1.36GHz	32.3/10.5
[5]	Novel microstrip resonator- interdigital structure	1.7	10×4.6mm	900MHz	20
[6]	Multiple coupling path	-	0.027λ <sub>g</sub>	1.05/1.3/1.5/1.8/2.05/2.35/2.85GHz	8/4/5/7.5/4.5/5.5/6.5
[7]	Standing-wave property of voltage distribution along an open-circuited λ/2 microstrip transmission line	0.8	0.586×0.317λ <sub>g</sub>	1GHz	30
[8]	Symmetrical quasi-reflection less differential-mode	1.9/1.7	-	2.82/3.21MHz	5.2/5.1
[9]	Distributed and symmetrical quasi-absorptive filter	1.1	-	2.2/2.76GHz	22.8
[10]	Loaded open/short circuited studs	0.3/0.7	0.28×0.20λ <sub>g</sub>	2.4/5.2GHz	51.9/23.3

#### 4. Conclusion

Wide band and dual-band filters are widely used in wireless application. Microstrip dual-band bandpass filter provides compactness, low cost and easy to fabricate. This paper compares the parameters like operating frequency, insertion loss, fractional bandwidth, technique and size of different microstrip dual-band BPF.

#### Reference

- [1] Sheng Sun, Lei Zhu., Compact Dual-Band Microstrip Band pass Filter without External Feeds. IEEE, Vol. 15, No. 10, October 2005.
- [2] Yue Ping Zhang, Mei Sun., Dual-band Microstrip Bandpass Filter Using Stepped-Impedance Resonators with New Coupling Schemes. IEEE, Vol. 54, No. 10, October 2006.
- [3] Chao-Hsiung Tseng, Hsin-Yung Shao. ,A New Dual-band Microstrip Bandpass Filter Using Net-Type Resonators. IEEE, Vol 20, No. 4, April 2010.
- [4] Runqi Zhang, Lei Zhu. ,Design of a Compact Dual-band Bandpass Filter Using Coupled Stepped-Impedance Resonators. IEEE, Vol. 24, No. 3, March 2014.
- [5] B. A. Belyaev, A. M. Serzhantov, A. A. Leksikov, Ya F. Bal'va, An A. Leksikov. Novel High-Quality Compact Microstrip Resonator and its Application to Bandpass Filter. IEEE, Vol. 25, No. 9, September 2015.
- [6] Chi-Feng Chen, Sheng-Fa Chang, Bo-Hao Tseng., Design of Compact Microstrip Step-Band Bandpass Filter With Flexible Passband Allocation. IEEE, Vol. 26, No. 5, May 2016.
- [7] Chuantao Cai, Jianpeng Wang, Lei Zhu, Wen Wu. ,A New Approach to Design Microstrip Wideband Balun Bnadpass Filter,. IEEE, Vol. 26, No. 2, February 2016.
- [8] Roberto Gomez-Garcia, Jose-Maria Munoz-Ferreras, Wenjie Feng, Dimitra Psychogiou. . Balanced Symmetrical Quasi-Reflection less Single- and Dual-band Bandpass Filters. IEEE, Vol. 28, No.9, September 2018.
- [9] Xiaohu Wu, Yingsong Li, Xiaoguang Liu., High-Order Dual-band Quasi-Absorptive Microstrip Coupled-Line Bandpass Filters. IEEE.
- [10] Gen-Zhu Liang, Fu-Chang Chen. .A Compact Dual-Wideband Bandpass Filter Based on Open-/Short-Circuited Stubs. IEEE, Vol. 8, January 2020.

# Wireless Charger for Artificial Pacemaker

Abinaya.B<sup>a,1</sup>, Abirami.A.P<sup>b</sup>, Divya.J<sup>b</sup> and Rajalakshmi.R<sup>c</sup>

<sup>a,b</sup>UG Scholar, Dept of ECE, Panimalar Engineering College, Chennai, India

<sup>c</sup>Associate Professor, Dept of ECE, Panimalar Engineering College, Chennai, India

**Abstract:** The vast majority of the modernized implantable devices and Bio-sensors are set inside a patient's body. To overcome this constraint, in this paper we have designed a rechargeable battery with wireless power transfer technique. The transdermal power transfer for the Pacemaker which is placed inside the heart should be possible by the concept of mutual inductance. The receiver loop ought to be situated inside the body and the transmitter coil ought to be situated outside of the body. The voltage controller will give or manage the necessary yield (output) voltage. The experiments were conducted on wireless charging through pork tissues reveal that from a 3.919-mw power source, 3.072-mw power can be received at 300kHz, reaching a high wireless power transfer efficiency of 78.4%, showing that the charging is very fast. We have also connected a Bluetooth Module to the Atmega328 microcontroller. This Bluetooth technology is used in the Android mobile application to notice the charging levels of the pacemaker. This Inductive power transfer technique takes out the danger of contamination which is brought about by the medical procedure.

**Keywords:** Microcontroller, Pulse-sensor, Mutual Induction, wireless charging.

## 1. Introduction

The implantable cardiac pacemakers have been playing a very important role in treating a wide range of cardiac disorders and have been recognized as life savers for the patients with cardio vascular diseases. In case of any absence of intrinsic impulses, the pacemaker stimulates the heart. Millions of people around the world have benefited from the systems such as implantable cardiac pacemakers. These systems are commonly used to treat patients suffering from arrhythmia – a disease caused due to the abnormal activity of the heartbeat. Nonetheless, there is an enormous limitation regarding the power supply. At present, the Bio-implantable pacemakers were powered using the disposable lithium-iodine batteries. Since the batteries used for these pacemakers are disposable in nature, they just last from 5 to 10 years or a normal of seven years. Once, the pacemaker battery is depleted completely, it is prudent to supplant the pacemaker with a fresher one, which can be done by doing a medical procedure. To beat this limitation, we have proposed wireless power transmission method using Inductive coupling. This method also avoids the risks like infections and allergies caused in the elderly people as a result of performing a surgery.

---

<sup>1</sup> Rajalakshmi.R, Associate professor/ECE, Panimalar Engineering College, Chennai, India.  
Email:rajeeramanathan@gmail.com

## 2. Existing System

The current implantable pacemaker is controlled with lithium-iodine battery, which can last from 5 to 10 years or more – on the normal around seven years, now often weightless than 30g. They are usually implanted subcutaneously in the intracavicular area. The energy which is needed for the activity of hardware of the pacemaker is given by this battery, which incorporates the control, detecting and heartbeat producing units. The current drain depends on the electrode types, pulse generation types and also the circuitry of the pacemaker. As the life span of a heart pacemaker implies its battery life, it is fundamental to have the hardware to distinguish the left-over existence of the battery in a basic and dependable way.

### 2.1 Literature Review

We have surveyed these papers which are centered on the wireless power transfer techniques for biomedical applications. These papers were arranged with in the descending order supported the year they were published.

**Table 1.** Literature Review

S.no	Journal	Year	Authors	Findings
1	IEEE Miniaturized wireless power transfer system for neuro stimulation [1]	2020	Gian Luca Barbruni, PaoloMottoRos, DaniloDemarchi, SandroCarrara, Diego Ghezzi [1]	Compares and uniquely selects the most suitable wireless power transfer method for neuro stimulation with minimally invasive miniaturized implants [1].
2	IEEE Bio integrated and wirelessly powered implantable brain devices [2]	2020	Rupam Das, FarshadMoradi, HadiHeidari [2]	Designed a system for bio-integrated and wirelessly powered Implantable neural devices in animals aimed at long-term neural interfacing [9].
3	IEEE Wireless power receiver with wide dynamic range for bio-medical implants [10]	2019	Hankyu Lee, Seungchul Jung, YeunheefHuh, SangJoonKim [10]	Proposes a wireless power receiver with wide input power dynamic range and includes a Dickson-charge pump for low power region and active rectifier for high efficiency at high power region [3].
4	IEEE Practical Inductive link design for Biomedical Wireless Power Transfer [4]	2018	Matthew Schormans, VirgilioValente, Andreas Demosthenous [4]	Proposed a method which reviews the equations that are required to design an inductive link for biomedical wireless power transfer, with a focus on practicality [11].

5	IEEE A Wireless Charging Circuit with high power efficiency and security for implantable devices [12]	2016	YaoLu,HanjunJiang, SongpingMai,ZhihuaWang [12]	Aims at inductively coupled implantable medical applications with wide range input-voltage and light output load along with a state checking operation ensures the security of the whole system [5].
6	IEEE Optimal Design of Wireless Power Transmission Link for millimeter-sized Biomedical Implants [6]	2015	DukjuAhn, MaysamGhovanloo [6]	Developed a method which presents a design methodology for millimeter sized implantable biomedical devices. Power Transfer Efficiency is maximized because of the optimal operating frequency found.
7	IEEE Wireless Power Systems for charge super capacitors as power sources for implantable devices [7]	2015	Pablo Aqueveque, JulianBarboza [7]	Presents a wireless power charging system for storage energy in supercapacitor as a power source for bio-medical implants by using a class E amplifier to give voltage to an inductive link and storage energy in a supercapacitor [7].
8	IEEE Bluetooth based low energy Qi compliant battery charger for implantable medical devices [8]	2014	SamiHached, Arefrigui, ImaneElKhalouffi, MohamadSawan, OlegLoutochin, JacquesCorcos [8]	Presents a smart battery charging system implementing the Qi wireless power transmission standard. Proposed device offers the possibility of charging batteries with any Qi certified power transmitter [8]

### 3. Proposed System

To overcome the limitations, present in the disposable lithium-ion batteries, wireless power transmission method using inductive coupling is proposed. coupling deals with the guideline of attractive field acceptance between two loops. Here, essential loop is set external the human body, which goes about as remote transmitter, though auxiliary curl is set inside the body close to the heart which goes about as a remote beneficiary. Essential curl of the energy transmitter creates a fluctuating attractive field across the optional loop of the energy recipient inside the field.

#### 3.1 Voltage Regulators

The LM78XX (Voltage regulator) arrangement of three terminal controllers is accessible with many fixed yield voltages which makes them helpful in a different scope of utilizations. The 12v/1A lead-acid battery connected to the wireless receiver gets charged from the receiver as a result of mutual induction. Additionally, a pulse sensor is added to the battery charging circuit.

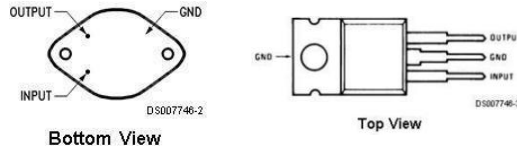


Figure 1. Source: Google

### 3.2 Pulse Sensor

Pulse sensor is a small electronic device that consists of pulse generator and sensing unit for sensing the electrical activity of the heart and provides electrical stimuli in order to trigger cardiac contraction if the heart rate is abnormal. The pacemaker is in “fixed pacing mode” by default while placing it over patient’s body. When it is in an “operating mode” a time interval in between the pulses are measured that provides the battery energy which is helpful in predicting life expectancy of devices. A real time long term and continuously monitoring the activity of pacemaker is desirable.

### 3.3 Bluetooth Module



Figure 2. Source: Google

For transparent wireless communication setup, a Serial Port Protocol is designed. It’s a Bluetooth module that has radio transceiver and base band of 2.4GHz along with the modulation rate of 3Mbps. These components are connected to the Atmega328 microcontroller. This is safe for human tissues and electromagnetic compatible with the cardiac pacemaker.

## 4. Result and Conclusions

In our paper, a wireless charger for artificial pacemaker is explained by an approach of inductively coupling wireless transmission technique. This enables one to achieve an optimized coil design after taking tissues properties and the device oriented into account. The total time to charge the battery is very fast as a result of high wire-less power transfer efficiency of 78.4%. This paper provides a new vision to people for charging a pacemaker which is embedded in one’s body without many hazards, and it will also be cost effective. Hence, this method of approach is one of the cheapest solutions which might be easy to implement in future pacemaker and it will also increase user’s satisfaction based on their requirements.



## References

- [1] Gian Luca Barbruni, Paolo Motto Ros, Danilo Demarchi, Sandro Carrara, Diego Ghezzi. Miniaturised Wireless Power Transfer Systems for Neuro stimulation: A Review, *IEEE Transactions on Biomedical Circuits and Systems*,2020
- [2] RupamDas, Farshad Moradi, Hadi Heidari., Bio integrated and wirelessly powered implantable brain devices.*IEEE Transactions on Biomedical circuitsandsystems*,2020
- [3] Hankyu Lee, Seungchul Jung, Yeunhee Huh, Sang JoonKim. Wireless Power Receiver with Wide Dynamic Range for Biomedical Implants,2019 *IEEE Wireless Power Transfer Conference (WPTC)*,2019
- [4] Matthew Schormans, Virgilio Valente, Andreas Demosthenous. Correction to Practical Inductive Link Design for Biomedical Wireless Power Transfer: A Tutorial [Oct 18 1112-1130]”, *IEEE Transactions on Biomedical Circuits and Systems*,2019
- [5] Yao Lu, Hanjun Jiang, Songping Mai, Zihua Wang.A Wireless Charging Circuit with high power efficiency and security for implantable devices”, 2016 *IEEE Biomedical Circuits and Systems Conference (BioCAS)*, 2016
- [6] Dukju Ahn, Maysam Ghovanloo, Optimal Design of Wireless Power Transmission Links for Millimeter-Sized Biomedical Implants, *IEEE Transactions on Biomedical CircuitsandSystems*, 2016
- [7] Pablo Aqueveque, Juliano Barboza, Wireless power system for charge super capacitors as powersources for implantable devices, 2015 *IEEE PELS Workshop on Emerging Technologies: WirelessPower (2015 WoW)*, 2015
- [8] SamiHached, ArefTrigui, Imane ElKhalouffi, Mohamad Sawan, Oleg Loutochin, Jacques Corcos.A Bluetooth-based Low-Energy Qi-compliant battery charger for implantable medical devices .2014 *IEEE International Symposium on Bioelectronics and Bioinformatics (IEEE ISBB 2014)*, 2014
- [9] Internet Source - [eprints.gla.ac.uk](http://eprints.gla.ac.uk)
- [10] Internet Source - [www.wpw2019.org](http://www.wpw2019.org)
- [11] Internet Source - [repository.tudelft.nl](http://repository.tudelft.nl)
- [12] Internet Source- [researchr.org](http://researchr.org)

# Accident Prevention Black-Box and Vehicle-to-Vehicle Communication Using Li-Fi and Wi-Fi Technologies

Aishwarya I<sup>a,1</sup>, Carolin B<sup>b</sup>, ChalceEbenS<sup>b</sup>, Dr. P. Kannan<sup>c</sup>

<sup>a,b</sup>UG Scholar, Dept of ECE, Panimalar Engineering College, Chennai, India

<sup>c</sup>Head of Department, Dept of ECE, Panimalar Engineering College, Chennai, India

**Abstract:** The focus of the paper is Vehicle to Vehicle (V2V) communication system that uses a wireless communication technology using a LED transmitter and therefore the vehicle will transmit the information continuously to the opposite vehicle ahead it using Head light. The data is stored within the Secure Digital Card in comma separated value for future reference just in case of emergency at the equivalent time the data's are stored in the Cloud Server for Government Reference to locate the accident prone zones. The Light fidelity (Li-Fi) is that the newest technology within the field of wireless communication. As the number of users are increasing, the speed of knowledge transmission within the wireless network gets automatically decreased.

**Keywords:** Wireless-Fidelity (Wi-Fi), Light-Fidelity (Li-Fi), Light Emitting Diode (LED), Visible light communication (VLC), Stored Data, Accident Detection System, Black Box.

## 1. Introduction

The modern technology is always in a state of constant evolution, utilising all the resources available to make man's life a better place. Harald Hass, a professor from the university of Edinburgh, UK had come up with an idea of communication through light and termed it as 'Light-Fidelity' or 'Li-Fi', similar to the concept of wireless fidelity (which utilises radio waves to transmit data) but uses the visual light range to pass the information between the devices. Humans sometimes may make rash decisions under pressure resulting in an accident. Likely so, in highways at night. Practically, there can never be a 100% result and accidents occur due to an unforeseen cause. In this report, the focus is on improving the current vehicle-to-vehicle communication system and makes it more reliable. While taking in to account of the limitless potential of the visual light communication technology and integrating it with a Black box analysis system, it is made to give a detailed report on severity of the accident and possibly giving a clue on how the accident had occurred, making the medical help be more prepared to provide effective treatment, thus saving lives.

---

<sup>1</sup>Aishwarya.I, UG Scholar, Dept of ECE, Panimalar Engineering College, Chennai, India.  
E-mail: aishwaryailango1703@gmail.com

## 2. Related works

Nikhil Kumar, et al. [1] have proposed an accident detection model that works continuously whether accidents are detected or not and notifies the predetermined services selected in case accidents occur. The system classifies accidents so that the appropriate rescue operations can be taken. The disadvantage of the proposed system is that if an accident is occurred there is no data stored and available for future reference. Ali Hassan, et al. [2] have proposed an automatic accident detection system that uses an android app, vibration sensor, accelerometer, and Bluetooth module. The model relays alter SMS with precise location of the crash. The disadvantage of the model is that it cannot communicate with a nearby vehicle. Rahul George, et al. [3] have proposed a review on Li-Fi for Vehicle-to-Vehicle Communication. The journal proposes a model for vehicle-to-vehicle communication using Li-Fi technology. Li-Fi used essentially for its speed, High-density coverage, security, cost efficient and larger spectrum. The disadvantage of the paper is that it does not have a functioning model. Namrata H. Sane, et al. [4] have proposed a vehicle accident detection and tracking using GSM and GPS system. The system consists of an accident detection unit that is installed in the front and rear of the vehicle. The accident detection unit is integrated with Push on Switches, if an accident occurs then the Push on Switch senses the object and transmits a signal to interrupt pins of the microcontroller module. The system can be handled manually in case of minor accidents. The disadvantage of the proposed system is that it doesn't have an analysis module for after the occurrence of an accident. V Anupriya, et al. [5] have proposed an accident notification and collision avoidance system. The proposed system avoids accidents due to collisions between vehicles. It has an integrated smart rescue system in the corresponding vehicle that send the location of the spot in which the accident has occurred to the nearest hospital or clinic. And also the smart rescue system updates the health status of the patient and sends the status to the nearest hospital. The disadvantage of the proposed system is that it doesn't facilitate vehicle to vehicle communication. Hema Patel, et al. [6] have conducted Survey on Li-fi technology and its applications. The following paper emphasizes on the importance of Li-fi, its working, application, which includes security, connectivity and navigation. The disadvantage is that the paper doesn't discuss the applications of Li-Fi in real time.

## 3. Proposed System

The proposed system contains v2v Communication using Li-Fi because Li-Fi is a fastest means of communication at the current period and Black-Box System is added to identify when, where and how the fault is occurred during accidents. Thereby making the system more trustworthy. The Fig. 1 is the block diagram of the transmitter module and Fig. 2 is the block diagram of the receiver module in setup.

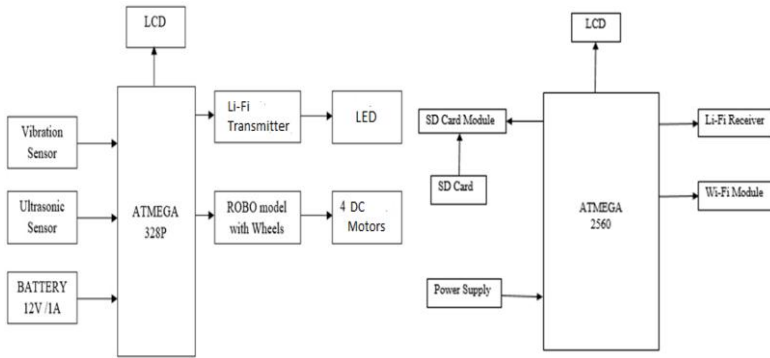


Figure 1. Transmitter module

Figure 2. Receiver module

#### 4. Requirements

The hardware components used are Arduino MEGA 2560, Arduino ATMEGA 328P, LCD screen (16x2), Vibration Sensor, Ultrasonic Sensor, Piezoelectric Sensor, SD Card Module, Power Supply and Li-Fi transmitter and receiver. The cloud service used for this setup is ThingSpeak (<https://thingspeak.com/>). The software used to program the instructions into the Arduino is ArduinoIDE 1.8.13.

#### 5. Working

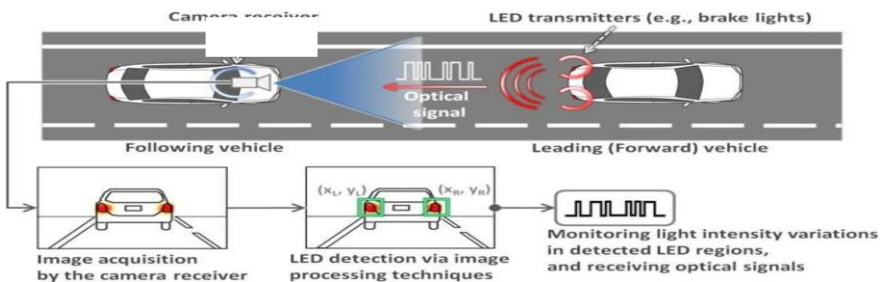


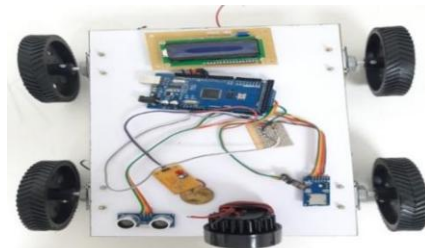
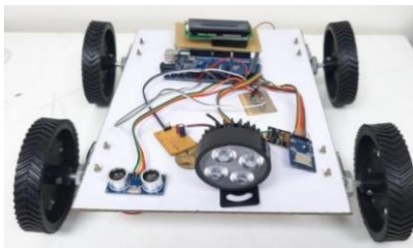
Figure 3. Working Module

##### 5.1 Working Description

The above Fig. 3 is the working module. The goal of this setup is to relay 'alert messages' to the drivers in time, thereby preventing possible accidents. The messages are passed by the use of Visual Light Communication and wireless fidelity (Wi-Fi) system in the vehicles. The distance between the vehicle nearby and its speed is measured using Ultrasonic sensor. The microcontroller module controls the entire system and notifies the driver with an "alert message" when the nearby vehicle meets

the line of sight. The black box system consists of a SD card module that stores information at regular intervals and stores it on the cloud. The stored information can be later retrieved in case accident has occurred. The black box system can be useful even if the vehicle-to-vehicle communication fails. The proposed system is very beneficial especially during the night time, where there is difficulty in vision and the lack of CCTV makes it hard to figure out the reason behind the accident occurred. To make it more effective black box concept is implemented here which stores the data in Wi-Fi and SD card which could be used if any mishap takes place and will play a major role during interrogation. The distance between the vehicles must be less than 30cm, so that the ultrasonic sensor detects and stops the vehicle automatically. Later the data is stored in the cloud and SD memory card for future reference. According to the German physicist Harald Hass, Li-Fi provides more speed (10megabits per second) data transmission by using visible light. In this,the speed of Li-Fi and Wi-Fi are compared and analyzed. The existing system has a transmitter and a receiver in each vehicle in both rear and front sides of the vehicle. Two scenarios will be studied in this paper. When the vehicle 1 is in the range of detection, a message will be sent through the transmitter which is placed in the rear lights to vehicle 2. A photodiode which is placed at the front of vehicle 2 to receive a notice of alert will be displayed in vehicle 2 using an LCD display. The message containing the information will be received by the photodiode in vehicle 2 and compared to vehicle 2 speeds. All the details of the road conditions from the first vehicle can be known only when the user is inside the car. The exact latitude & longitude parameters of the vehicle can be known.

## 6. Result and Discussion



**Figure 4.** The top view of the Transmitter model. **Figure 5.** The front view of the Receiver model.

The above Fig. 4 is the top view of the model of Vehicle 1 and Fig. 5 is the front view of the model of Vehicle 1. Due to the extended communication range, this technique can provide certain information about other vehicles equipped with an equivalent technology. The system also helps to determine the location and time of the accident.



**Figure 6.**Distance measured between vehicle 1 with respect to time. **Figure 7.** Vibration measured between vehicle 1 and 2 with respect to date and time.

The Fig. 6 shows the distance with respect to the date of the travel. If the distance between the vehicles varies then the graph also varies accordingly. The distance range between the vehicles in the setup is less than or equal to 30cm. The Fig. 7 shows relation between the sensor values with respect to the date & time of the vehicle. When an accident takes place, the graph increases drastically. The vibration sensor measures the force caused during the collision of the vehicle.

**7. Conclusion**

This paper integrates the advantages of Li-Fi, Wi-Fi and the Black Box systems into one and so, increases the fault tolerance rate when either one of the systems fail. The setup can be used as a proof of concept that at these experimental values (from basic components used in setup) and the alert messages are relayed correctly and accidents can be prevented experimentally and theoretically. The system successfully uses visible light to transmit the data from one vehicle to another. The data is stored in real-time in a cloud server with date and time and a SD card. The data uploaded to the cloud is easily accessible with legal authority and is also password protected to prevent any unauthorized access to the data thus making it secure.

**References**

- [1] Nikhil Kumar, Debopam Acharya, and Divya Lohani, An IOT Based Vehicle Accident Detection and Clarification System using Sensor Fusion,
- [2] Ali Hassan, M. Shahroz Abbas, Muhammed Asif, Maaz Bin Ahmad, M. Zubair Tariq, An Automatic Accident Detection System: A Hybrid Solution, 2019 4<sup>th</sup> International Conference on Information Systems Engineering (ICISE).
- [3] Rahul George, Srikumar Vaidyanathan, Amandeep Singh Rajput, K Deepa, LiFi for Vehicle to Vehicle Communication – A Review, International conference on recent trends in advanced computing 2019, ICRTAC 2019.
- [4] HN. H. Sane, D. S. Patil, S. D. Thakare, and A. V. Rokade, Real Time Vehicle Accident Detection and Tracking Using GPS and GSM , International Journal on Recent and Innovation Trends in Computing and Communication, Archived from the Original, Accessed 24 June 2018.
- [5] V. Anupriya, B. Lissy Roy, V. Dheepthi and F. Masood. Smart Accident Notification and Collision Avoidance System . International Journal of Engineering Research and Technology, 4(4), pp. 1148-1152, 2015.
- [6] Hema Patel, Survey on Li-Fi Technology and Its Application . International Journal of Information Sciences and Techniques (IJIST) Vol .6, No.1/2, March 2016.

# Vision Atrophy Screening and Revelation

Kiruthiga Devi M<sup>a</sup>, Lingamuthu K<sup>b</sup>, Baskar M<sup>b</sup>, Deepa B<sup>c</sup> and Merlin G<sup>d</sup>

<sup>a</sup>Assistant Professor, Dept of CSE, Sri Sai Ram Engineering College

<sup>b</sup>Student, Dept of CSE, Sri Sai Ram Engineering College

<sup>c</sup>Assistant Professor, Dept of IT, Sri Sai Ram Institute Of Technology

<sup>d</sup>Assistant Professor, Dept of IT, Kings Engineering College

**Abstract:** Glaucoma which is known as the "thief of sight", is an irreversible eye disease. It is mainly caused by increased intraocular pressure (IOP), or loss of blood supply to the optic nerve. Glaucoma detection and diagnosis is very important. By analyzing the optic disc and its surroundings, this paper introduces a method for providing automated glaucoma screening services based on a framework that proposes a retinal image synthesizer for glaucoma assessment by analyzing the optic disc and its surroundings. The Cup to Disc Ratio (CDR) is critical for the system, and it is calculated using 2-D retinal fundus images. The synthetic images produced by our system are compared quantitatively. The structural properties of synthetic and real images are analyzed, and the quality of colour is calculated by extracting the 2-D histogram. The system allows patients to receive low-cost remote diagnostics from a distance, preventing blindness and vision loss by early detection and management.

**Keyword:** CDR value, Fundus Image

## 1. Introduction

Vision loss caused by glaucoma cannot be reversed, unlike other eye disorders such as cataracts and myopia[1]. By 2021, it is expected to hit about 80 million people around the world. Many glaucoma patients are unaware of their disease. As a result, early detection is critical for early care in order to preserve vision and quality of life. Optic nerve fiber misfortune is the most common symptom, which is indicated by increased intraocular pressure (IOP) or probably a lack of blood flow to the optic nerve. Intraocular pressure (IOP) estimation, Function-based visual field examination, and Optic nerve head (ONH) evaluation are the three clinical tests used to screen for glaucoma[3]. The optic nerve head or optic disc can be visually divided into two zones in a 2D fundus image, a bright and central zone called the optic cup[2]. We then determine the CDR value in order to predict the potency of the disorder.

---

<sup>1</sup>Kiruthiga Devi M, Assistant Professor, Dept of CSE, Sri Sai Ram Engineering College, India  
E-mail: kiruthiga.cse@sairam.edu.in

## 2. Literature Survey

An ensemble approach for optic cup detection based on spatial heuristic analysis in retinal fundus images. Optic cup location stays a difficult assignment in retinal picture examination, and is of specific significance for glaucoma assessment, where illness seriousness is regularly evaluated by the optic cup size. They used the ORIGA informational array of 650 retinal pictures to conduct experiments and found that the group technique outperforms the separate divisions[1]. Local patch reconstruction framework for optic cup localization in glaucoma detection. cup confinement/division has drawn much consideration from clinical imaging analysts, since it is the essential picture segment clinically utilized for recognizing glaucoma, which is a main source of visual deficiency. Two sorts of neighbour hood patches, for example networks and super pixels are utilized to show the assortment, speculation capacity and vigour of the proposed system[2]. The existing system has been designed in such a way that the evaluation of the CDR value is completely based on 3D SCAN[10]. The patient's health is completely analyzed based on the scan report. With respect to 3D images, calculate the cup-to-disc ratio. The ILM (Inner Limiting Membrane) and RPE (Retinal Pigment Epithelium) layers, as well as the CDR value, are appropriately segmented using an efficient computer-aided technique that takes an OCT picture as reference[10]. Transitions in the inward retinal layers caused by glaucoma have been examined.

## 3. Proposed System

The proposed system tries to solve the problem by aggregating patients' two dimensional fundus image. The Image Synthesizer accepts the 2D Retinal Fundus Image, which was earlier collected by an non-invasive method. Images with marked CDR data are used for producing adequacy from the referred data and contrasting conditions, which are used during optic disc classification and redesign[5]. Our methodology could be used as a desktop glaucoma diagnostic tool. Ophthalmologists may help the persons irrespective of their place, pace or time.

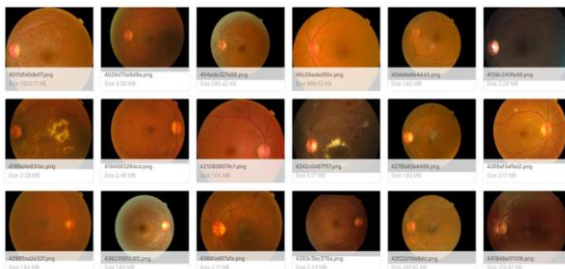
## 4. System Implementation

A plan with various modules, helps to lessen complexity, looks into modifications, and finally gives in easy implementation with improvement in various components of the project. Module 1: Image Synthesizer. Module 2: CDR Evaluation. Module 3: Algorithm (Testing & Predicting).

### 4.1. *Image Synthesizer*

In this module all the data about the patient's eye is extracted from the available and regularly collected 2D-Fundus image for analysis and evaluating the CDR value[8]. We approached our nearby Eye care Hospital and collected images of 2 patients, one tested positive and other with negative.

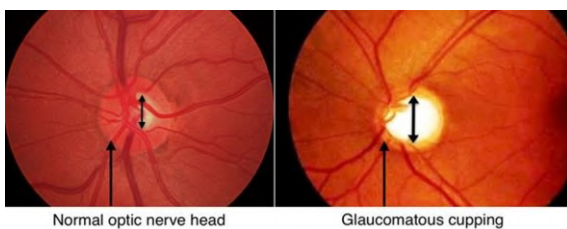




**Figure 1.** Set of collected 2D-眼底 images

#### 4.2. Dataset

We downloaded publicly available datasets from the internet, Example, Kaggle, data.gov.in, etc. In the image of a two dimensional fundus, there is an elliptic shaped part that is luminous than the others nearby called optic disc. Continuous intraocular pressure in OC within a glaucomatous eye might grow[1]. There is a reduction in the neuro-retinal edge that occurs in the middle of OD and OC with respect to the growth of OC. If the neuro-retinal rim becomes too thin, the vision quality will be blurred and destroyed.



**Figure 2.** Optic nerve head comparison with normal and affected eye

#### 4.3. CDR Evaluation

Finally, processing the 2D-image of the patient. We proposed an algorithm in the MATLAB software such that it concludes whether he/she tested for glaucoma disease resulted in a positive or negative note[7]. Detailed report about the patient is provided in form of pictorial representations like charts and graphs for easy understanding. Now this will give the ophthalmologist and patient an idea of the current scenario in their vision wealth.

#### 4.4. Algorithm

Read the image. Convert it into a binary and clear the border. Fill the holes in the binary image. Create a structuring element in the shape of a disk of radius 6 and dilate it (disk image). Create another structuring element with the same shape but radius of 2 (cup image). Find the disc boundary and mark it in the image. Find the ratio between the area of the objects in the disk image and the cup image as CDR ratio. Check If CDR ratio is less than 4.5 then “No Glaucoma ”If CDR ratio is between 4.5 and 6 then “No

glaucoma but risk of acquiring” If the CDR ratio is greater than 6 then “Glaucoma detected”.The fundus image of a patient is converted into a binary image and then it filters the binary image to locate the optical cup.

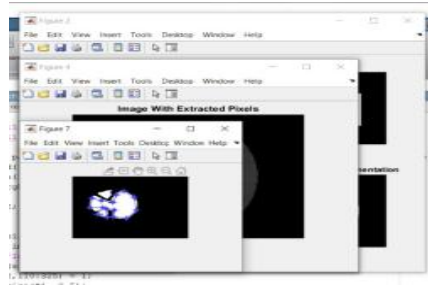


Figure 3. Image Enhancement (Cropping & Filtering)

Boundaries are marked for further enhancement, the specialty of our system is that, If our system is handled by the doctor. Then he/she can mark the location manually and specifically.

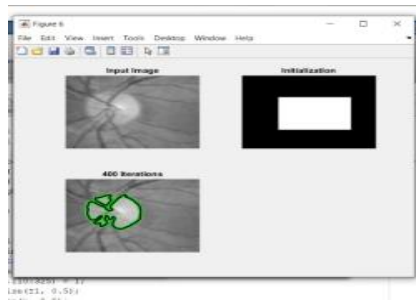


Figure 4. Area Formation

After this process gets over, Our system maintains the record of all the diagnostic results of a particular person in an excel sheet. It is then sent to the machine learning algorithm to predict the efficacy of the disorder and with which ophthalmologists can discuss the medications required for the affected person.

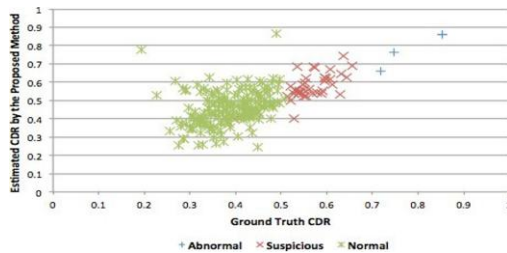


Figure 5. CDR Estimation

#### 4.5. Prediction

Initially, images were trained and tested on the features extracted from super pixels. One is LDC (Linear Discriminant Classifier) and the other one is NN(neural networks). Both achieved Higher accuracy for classifying cup and disc in the training. Therefore, it is used in the real time experiments Accuracy is the ratio between correctly labeled to overall subjects. Precision is ratio between correctly positive labeled to overall positive labeled. Recall is ratio between positive outcome of our program to overall who have positive in reality. The results have also shown the effectiveness of the approach with 90% specificity and 94% sensitivity.

$$\text{Accuracy} = \frac{\text{TP} + \text{TN}}{\text{TP} + \text{TN} + \text{FP} + \text{FN}} \quad \text{precision} = \frac{\text{TP}}{\text{TP} + \text{FP}}$$

$$\text{Recall} = \frac{\text{TN}}{\text{TP} + \text{FN}}$$

TP=True positive  
TN=True Negative  
FP=False Positive  
FN=False Negative

Figure 6. Accuracy, Precision, Recall

### 5. Conclusion And Future Enhancement

Glaucoma is a category of eye illnesses that cause the optic nerve and cause myopia. If not, it causes a lack of side sight, which makes it impossible to get around properly. Glaucoma will also impair the central vision over time. Thus, the novelty of our idea is to provide a diagnosis in more cost-effective and with greater evaluation accuracy, the proposed non-invasive method detects glaucoma eye at an early stage. Furthermore, the results can be extended for therapeutic applications. With automation at its highest point of saturation. The future of this project is to provide an easy accessible web and mobile application. The automatic detection glaucoma is provided by this application. As a result, it introduces a better platform for physicians to enhance their skills, coordinate patient budgets, and deliver improved treatment.

### References

- [1] Abramoff.M.D et al., Automated segmentation of the optic disc from stereo Color photographs using physiologically plausible features, *investigative ophthalmol. Vis. Sci.*, Vol. 48.
- [2] J. Xu et al., Optic disk feature extraction via modified deformable model technique for Glaucoma analysis, *pattern recognit.*, Vol. 40 pp.2063–2076, 2007.
- [3] Ms. Pooja Chaudhari Prof. Girish A.. Student at SSGB COET Professor at SSGBCOET, Review of different Image Processing Methods to Detect Glaucoma, *IJARECE* Volume 5, Issue 6, June 2016
- [4] Mrunalini Manchalwar, Krishna Detection of Cataract and Conjunctivitis Disease Using Histogram of Oriented Gradient, *International Journal of Engineering and Technology (IJET)* Vol 9 No 3 Jun-Jul 2017
- [5] Mixture model-based approach for optic cup segmentation, Tan NM, Liu J, Wong DK, Yin F, Lim JH, Wong TY *Journal of* 2019.
- [6] Chen.X, Y. Xu, S. Yan, D. W. K. Wong, T. Y. Wong, and J. Liu, Automatic feature learning for glaucoma detection based on deep learning, in *Medical Image Computing and Computer Assisted Intervention—MICCAI*. Cham, Switzerland: Springer, 2015, pp. 669–677.
- [7] Carmona.E.J and Rincón.M, J. García-Feijóo, and J. M. Martínez-de-la-Casa, Identification of the optic nerve head with genetic algorithms, *Artif. Intell. Med.*, vol. 43, no. 3, pp. 243–259, 2008
- [8] Argo, C., Sadiq, M.A., Hassan, M., et al, Assessment of change in retinal layers at the Macula in glaucoma patients and correlation to visual field index, *Investigate Ophthalmology and Visual Science*, ARVO Annual Meeting, Seattle, USA, 2016, vol. 57, p. 369

# Scraping and Analysing YouTube Trending Videos for BI

Sowmiya K<sup>a,1</sup>, Supriya S<sup>b</sup> and R.Subhashini<sup>c</sup>

<sup>a,b</sup>UG Scholar, Dept of IT, Sathyabama Institute of Science and Technology, Chennai, India

<sup>c</sup>Professor, Dept of IT, Sathyabama Institute of Science and Technology, Chennai, India

**Abstract:** Analysis of structured data has seen tremendous success in the past. However, large scale of an unstructured data have been analysed in the form of video format remains a challenging area. YouTube, a Google company, has over a billion users and it used to generate billions of views. Since YouTube data is getting created in a very huge amount with a lot of views and with an equally great speed, there is a huge demand to store the data, process the data and carefully study the data in this large amount of it usable. The project utilizes the YouTube Data API (Application Programming Interface) which allows the applications or websites to incorporate functions in which they are used by YouTube application to fetch and view the information. The Google Developers Console which is used to generate an unique access key which is further required to fetch the data from YouTube public channel. Process the data and finally data stored in AWS. This project extracts the meaningful output of which can be used by the management for analysis, these methodologies helpful for business intelligence.

**Keywords:** Datasets, Data Analysis, Social Media, BigData, Decision Making, Amazon S3, Cloud Computing.

## 1. Introduction

Now a days social media like Facebook, Twitter, YouTube and Google make the space for millions of users to share their opinion each other. In the rapidly increasing popularity, we have these sites that have become a source of massive amount in the real time data of videos, images etc. Among them, YouTube is one of the world's largest video sharing platforms, where videos are uploading continuously by the millions of users. The YouTube has emerged as a comprehensive and easy to access the compilation of video information source on the web. It is a unique environment with many facets such as multi-modal, multi-lingual, multidomain and multi-cultural. The versatility and attractive shared content draw the widespread attention. Therefore, the importance of YouTube is successively increasing for the industry and research community day by day. Increase interaction of user's , it allows users express their

---

<sup>1</sup> Sowmiya K,UG Scholar, Dept of IT, Sathyabama Institute of Science andTechnology, Chennai, India  
E-mail: sowmiyakumar1998nov@gmail.com

opinion by rating the viewed object's interaction and object with the community. Moreover, these data which serves the purpose of helping the community to filter relevant opinions more efficiently. The researchers continuously showing their interest in social media data analysing to exploiting rich content shared on YouTube. In earlier studies the videos not only using meta data, but also using comment. Unstructured formats in YouTube is comments and it's difficult part to analyse. In this paper we used a NLP sentiment analysis approach to find out the YouTube trending video. In this paper, seeking, how metadata useful for analysis. Data analysis is a process of processing, cleaning irrelevant data, transform the data, and modelling goal of discover, informing conclusion and help to promote decision making for business.

## 2. Relative Work

Several researches have taken from the different regions from the YouTube video methods [5]. In that regions from YouTube comments are the most important thing to create or to make a decision (like comment rating, searching the topics related to the categories etc.,) of the particular chosen video [6]. The above searched comments are used to promote the video objects that are taken from the particular chosen video [7, 9]. The Comments will also shows us the users behaviour and we could able to find out the most repeated comments and the troll messages about that video or the video maker and we could find the troll makers [1]. After analysing the objects of the comments it is easy and it is possible to find out the users view on the v either it is positive or negative, and this is known as the sentimental analysis [10]. And on the basis of the comments we can able to categorize the trending videos in several category to know the users view [11, 12]. On the upcoming process for the improvement we can improve the video in the method based on the basic needs and the feature of the social medias or social networks [3]. And have to work on the YouTube trending videos regarding comments for like and dislikes for showing that user's thought that are influenced by the most valuable comments [4]. These two methods is use to find how popular that the video is trending and the categories that are trending , so that it could help us to retrieve the useful video for promoting the advertisements. These two proposed works [3, 4] shows that the interesting work for video and its retrieval process but they used like/dislike and views. But sometimes it may lead to the wrong or inaccurate results. And we analyse the large amount of comments instead of others comment like view and comments to find the related videos which can be useful to youtube users [11-14].

### 3. Proposed System

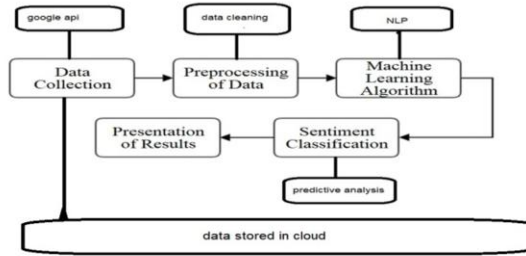


Figure 1. Architectural diagram

#### 3.1 Data Collection

Data collection is the process where we collect the data from the google API for seven different countries and each country has its own country code and the google API is in alpha numerical numbers and it also provides the overview of the functions.

Before starting the process

- First we should need the Google account to get the Access from the Google API console, then we have to request the key and register for our application.
- Then we have to create or form a project in the Google console and then we have to get the correct permission from that API for our application to submit our request.
- After completing our project, we have to make sure of the data that are collected from the YouTube API is registered for the application to use :
  - a. First we have to go to the Google API console and then we have to select our project that we have registered.
  - b. Then we have to check the form from API page that have been enabled and then we have to check whether the process is ON for the data in the YouTube API.
- The application may use any methods from the API and we have to understand properly that how to implement in that user authorization.
- Then we have to select the client lib to make clear for our progress.
- First we have to make clear about the concepts of the JavaScript Object Notation data format.
- Finally, in Spyder notepad we run the code to get the semi structured data.

#### 3.2 Data Processing

In the Data processing method the types and the methods to convert the normal information or normal messages to the high level knowledgeable and similar to the method in the data analysis process. The data that we are getting first must be processed for that analysis part. These data can involve in substituting or placing those data into rows and into columns in the form of table and it is also known as the structured data and in the future progress the analysis can be used in the form of spreadsheet or in the form of statistical software.

### 3.3 Data Pre-processing

After the processing method and after we organized the data, the data may be not in the proper form and it also have the chances of containing duplicates of that data and having some error in it. Then we must have to clean the unwanted data like cleaning the unwanted alpha numerical numbers on that data this will form the problems for the data that is stored and entered. And Data cleaning is the process of cleaning the data and removing the errors of that data. And some of the steps to include in the cleaning process is rectifying the inaccurate data and changing the duplicate data and for example, both trending date and publish time column include dates, but in different formatting. Publish time includes the time of publication and the date, while trending date only includes the date. Since we don't have the time the video started trending, we cannot compare it to the publish time. In the end, we will clean the data such that both columns include datetime.date objects then We will clean up the tags column by separating tags into a list instead of one long string. NLP process to remove title We developed a function to clean the video titles by removing stop words, non-alphanumeric tokens, and money amounts to better understand the occurrence of certain keywords being used in the titles.

### 3.4 Exploratory Data Analysis

After the datasets are cleared and cleaned and the next process was analysing part. The analysis part contains many methods and to start with it we can understand the messages which contain within the required data. And the process of exploring the data may give the result as the addition of cleaning the data or the addition of requesting the data. The analysing part will have the graph of showing that the frequency of the trending videos. And the next process will be Data visualisation process.

### 3.5 Data Visualization

Successfully cleaned our data, we will start exploring our data. We will start by looking at what words are commonly used in video titles, as we predicted that word choice will be an important factor for Trending videos. Figure 2, help to understand why top 10 channels with trending videos. may not coincide with the exploration of categories we did earlier as the distribution is extremely rightly skewed. Around 1450 YouTube channels have under 10 YouTube trending videos, while we have few trending channels over with 100 YouTube trending videos. Theses Visualization tells ,look too closely the top 10 YouTube channels won't help us as the majority we have below, that number of YouTube videos. Calculate the percentages of the number of YouTube trending videos theses channels have to focus more closely.

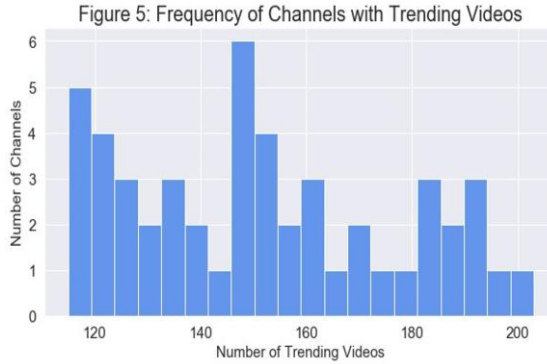


Figure 2. Number of trending videos by channel Percentage.

**Percentage = ( part / total ) × 100**

```
above_20 =len([iforiinchannel_freqifi> 20]) /len(channel_freq) * 100
percent_16_20 =len([iforiinchannel_freq if (i<= 20) & (i> 15)]) /len(channel_freq) * 100
```

```
percent_11_15 =len([iforiinchannel_freq if (i<= 15) & (i> 10)]) /len(channel_freq) * 100
```

```
percent_6_10 =len([iforiinchannel_freqif (i<= 10) & (i> 5)]) /len(channel_freq) *
```

```
100 percent_1_5 =len([iforiinchannel_freqif (i<= 5)]) /len(channel_freq) * 100
```

Number of Trending Videos by Channel

- 1 to 5->Videos -34.5%
- 5 to 11->Videos - 24.8%
- 11 to 5->Videos -10.8%
- 15 to 20->Videos -7.1%
- 21+ -> Videos - 22.9%

This demo, that more than 3/4 of channels have created under 20 YouTubetrending videos, with 34.5 percentage of channels having between 1 - 5YouTubetrending videos. This shows the top channels with well over 100 trending videos.

3.6 Stored In Amazon S3

Amazon Simple Storage Servicespecially formulated to stored Semi-structured data and Unstructured data.

1. Get starting with AWS management console and move to S3.
2. Creating bucket name is socialmdin ‘US East (Ohio) us-east-2’ region and stored the objects. (every object will have unique URL link)

Once objects have been stored in an ‘Amazon S3 bucket’; they are given an **object key**. Use this, along with the bucket name, to access the object. An **object key** is the



unique identifier for which an object in a bucket. Because the combination of a “bucket”, “key”, and “version ID” identifies uniquely each object, you can think of ‘Amazon S3’ as the basic data map between bucket + key + version and object. In each object in ‘Amazon S3’ can be uniquely called (or) addressed through the combination of the web service – ‘endpoint’, ‘bucket name’, ‘key’, and optionally (version). ‘Amazon S3’ is designed for durability, and its encrypted.

#### 4. Conclusion

This paper illustrates to get the right decision for digital marketing for company growth, especially marketer can market their product using smart analytical processes. YouTube trending video helps businesses understand how customers feel about their brand, giving them first-hand information to improve their products, make data-driven decisions, and deliver better customer experiences.

#### Reference

- [1] A. Severyn, A. A. Moschitt, Uryupina, B. Plank and K. Filippo, Multi-lingual opinion mining on YouTube, *Information Processing & Management*, 52(1), 2016, pp. 46-60.
- [2] YouTube data API documentation <https://developers.google.com/youtube/2.0/reference>
- [3] Cholera, S., C. Orellana-Rodriguez and I. S. Altingovde, How useful is social feedback for learning to rank YouTube videos, *In World Wide Web*, 17(5), 2013, pp. 1-29.
- [4] Schulte's, P., V. Dorner and F. Lehner, Leave a Comment! An In-depth Analysis of User Comments on YouTube, *Wirtschaftsinformatik*, 2013, pp. 659-673.
- [5] Siersdorfer, S., S. Cholera, J. S. Pedro, I. S. Altingovde and W. Nejdl, Analysing and mining comments and comment ratings on the social web, *ACM Transactions on the Web (TWEB)*, 8(3), 2014, pp. 1-39.
- [6] Siersdorfer, S., S. Cholera, W. Nejdl and J. San Pedro, How useful are your comments? analysing and predicting YouTube comments and comment ratings, *In Proceedings of the 19th international conference on World wide web (ACM)*, 2010, pp. 891-900.
- [7] Mokena, E., C. Cardie and M. Ott, Properties .Prediction, and Prevalence of Useful User-Generated Comments for Descriptive Annotation of Social Media Objects, *In Proceedings of ICWSM*, 2013.
- [8] <https://www.kaggle.com/ammari111/youtube-trending-videos-analysis>
- [9] H. Lee, Yeha, Y. Kim and K. Kim, Sentiment analysis on online social network using probability Model, *In Proceedings of the Sixth International Conference on Advances in Future Internet*, 2014, pp. 14-19.
- [10] Filippova, K. and K. B. Hall, Improved video categorization from text metadata and user comments. *In Proceedings of the 34th international ACM SIGIR conference on Research and development in Information Retrieval*, 2011, pp. 835-842.
- [11] Ambeth Kumar, V. D., Ramya, S., Divakar, H., Kumutha Rajeswari, G. A Survey on Face Recognition in Video Surveillance. *Lecturer Notes on Computational and Mechanism*, Vol. 30, pp: 699-708, 2019
- [12] Ambeth Kumar, V. D. Precautionary measures for accidents due to mobile phone using IOT. *Clinical eHealth*, Volume 1, Issue 1, March 2018, Pages 30-35.
- [13] Nanagasabapathy, K. et al. Validation system using smartphone luminescence. *IEEE International Conference on Intelligent Computing, Instrumentation and Control Technologies (ICICT)*, Pages: 235 – 239, 6-7 July 2017, Kannur, India
- [14] Ambeth Kumar, V. D. and Dr. M. Ramakrishnan, “Enhancement in Footprint Image using Diverse Filtering Technique”, *Procedia Engineering journal*, Volume 8, No.12, 1072-1080, March 2012 . [doi:10.1016/j.proeng.2012.01.965]

# AR Guide for Food Allergic Consumers

Karthika. S<sup>a,1</sup>, Varsha.G<sup>b</sup> and Deepika. R<sup>c</sup>

<sup>a,b</sup>Student, , Dept of CSE, Sri Sairam Engineering College, Chennai

<sup>c</sup>Assistant Professor, Dept of CSE, Sri Sairam Engineering College, Chennai

**Abstract:** Augmented reality is a technology where real life environment is enhanced by incorporating digital or virtual elements like images, graphics, 3D objects into it. Augmented reality is a growing and trending technology which can make interactions easier when incorporated into normal applications. The aim of this project is to create an augmented reality food guide for food allergic consumers to aid them in choosing allergen free foods. A person who wants to order food online or in restaurants doesn't know whether it would be suitable for him to eat or not. Especially if they are allergic to certain foods, they have to be preventive and cautious in choosing the type of food they eat. This AR guide will aid them in choosing the suitable food for them in an augmented environment where a consumer can view food in three dimension view along with the necessary information about the food such as the key ingredients and the presence of any allergens that will be helpful in choosing the allergen free food.

**Keywords:** Augmented reality, 3d modelling, food labelling.

## 1. Introduction

Augmented Reality (AR) is a recently emerging technology that enhances the real life environment by incorporating computer generated two or three dimensional elements such as texts, images, graphics, etc. It offers enhanced level of interaction with the environment by employing virtual information to it. An augmented reality application (AR) provides flexible and user interactive learning and visualizing environment to users. AR is mostly used in education for demonstrating concepts that require realistic visual objects. However it can also be applied in various fields such as entertainment, healthcare and food industry. There are many systems for food ordering online. But these systems do not provide any means to help the consumers who are allergic to certain foods. Also, sometimes even non allergic consumers may find it difficult to order food online if it is something out of their regular pick. In such case, they might have to do searches online to learn about the kind of food they are ordering. There is no system to visualize food the way it is in the real environment along with the necessary health information that can aid those with allergic reactions to certain foods before they order them. However augmented reality can be a perfect solution for this. Using three dimensional models of the food along with the vital information about the food can be

---

<sup>1</sup> Karthika S, Student, , Dept of CSE, Sri Sairam Engineering College, Chennai;  
E-mail:karthibhatia06@gmail.com

very useful to both allergic and non-allergic consumers in choosing their foods according to their preferences. Using target images such as markers or by detecting flat surfaces augmented reality application can scan images through the camera of a smart phone and can generate 3D models of the food that can help both the allergic and non-allergic consumers in ordering the food of their preference without any confusion. This paper aims to discuss the development and implementation of an augmented reality (AR) application aiding both allergic and non-allergic consumers in choosing the food of their preference. Section 2 discusses the related works; Section 3 discusses the proposed system methodology; Section 4 discusses the design modules; Section 5 discusses the results and this paper concludes at Section 6.

## 2. Related work

Meghan E. Rollo et al. (2017) did a detailed study on an AR app called servAR to check to what extent it can help in estimating carb choices of the food. The app showed carb choices on a real dish virtually using an iPad Mini which included nine foods such as pasta, green beans, rice, corn, broccoli, potatoes, cauliflower, kidney beans and carrots. The study reported that the ServAR app showed improved carb-choice accuracy and great potential as a tool to support the estimation of carb choices.[7] AR Breakfast (Calle-Bustos et al., 2017) is an augmented reality app that is developed for supporting therapeutic education for diabetic patients. It helps the patients learn about the carb choices of foods they eat. This app places virtual food on a marker along with the carb information so the patients can learn the carb choices of the food they eat. The results showed that the diabetic patients earlier unaware of the carb choices learnt about them after using the app.

## 3. Proposed system methodology

A sample application with a simple user interface is developed to test the performance practically. The user interface allows the user to choose a dish from a cuisine. This AR guide will have 3d food models along with the necessary information about the food which will be projected virtually in real time using target detection and 3d augmentation techniques. A common target will be set and the 3d food models along with the information will be projected on that target which will help the consumers in choosing the food to eat.

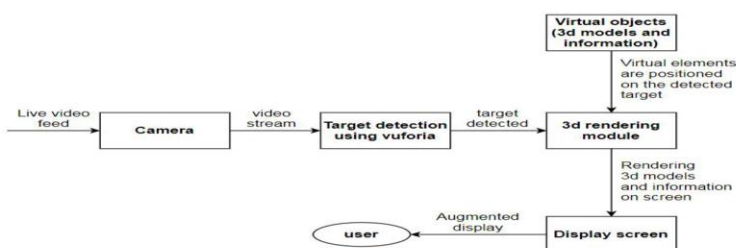
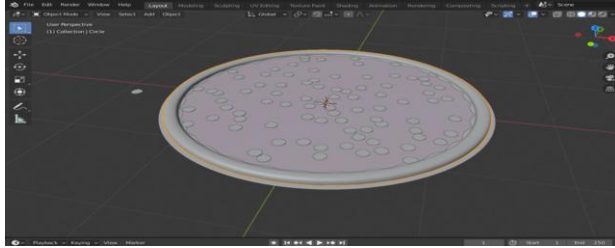


Figure 1. Block diagram representing the process

## 4. Design module

### 4.1 3D model constructions

Reference images are collected. Basic shapes are scaled, sculpted and adjusted in blender to create a rough model. The model is rendered by applying suitable modifiers to create a textured model. The materials and textures are applied to the model in unity.



**Figure 2.** Rendering a model in blender

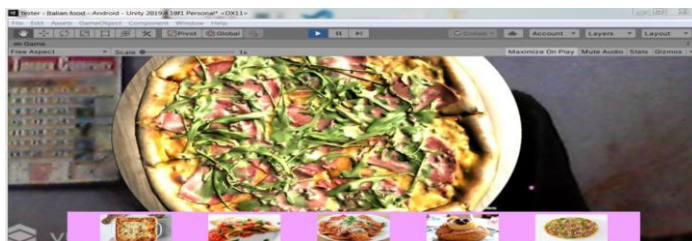
### 4.2 Target detection and 3d model augmentation

#### 4.2.1 Target detection

Vuforia is one of the famous sdk used for target detection and it has many tools required for creating an AR experience. Vuforia detects the target at run time in the live camera feed by comparing the features of the target with that of the features extracted in the predefined target image. Vuforia rates the target to be used from 0 to 5 stars. The higher the rating, the greater and more accurate the detection.

#### 4.2.2 3d model augmentation

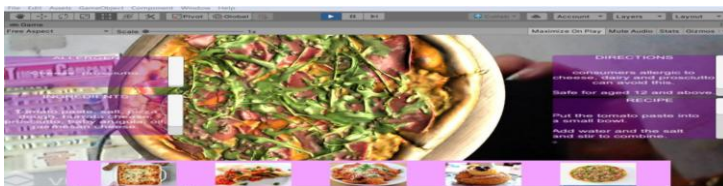
After target detection, 3d models are mounted on the target image so as to display them on the target whenever the target image is shown on the camera. Augmentable target image that has distinct features is chosen and set as a target. The target is adjusted in the scene as per the position of the camera coordinates. 3d model is positioned on the target image and programmed to be activated on button click. The process is repeated for all the models in different scenes.



**Figure 3.** 3d model augmentation "Pizza" (<https://skfb.ly/6RqYo>) by Rigsters

### 4.3 Information augmentation

Information about the food featured are collected from various sources and classified as allergens, key ingredients, directions and recipe and consolidated to facilitate the data feed. The information is displayed in four different columns that the consumer can see along with the 3d display of the food.



**Figure 4.** Augmented display containing 3d model of food and its information.

### 4.4 User interface

User interface acts as a bridge between the user and the application. User interface is an important factor in application development process. A good flexible user interface lets the user to interact with the application with ease. A good application will have user friendly interface that will allow the users to interact with the application without any prior knowledge about the application. In this, user interface will have home page where the list of cuisines will be displayed in buttons. A click on the button will lead to another scene where there will be dishes of the respective cuisine featured. The application will show the 3d model of the dish clicked along with its information on the screen when the target is shown to the camera.

## 5. Results and future enhancements

The above approach can be applied in restaurants and hotels to ensure the safety and wellbeing of their customers. This approach not only helps food allergic consumers but also non allergic consumers in choosing the kind of food they eat. This approach only acts as an aid guide for the consumers but it can be enhanced in future by detecting a

nearby restaurant that has the foods featured in this application with the help of gps services and providing a means to order that particular food online without having to look for the places elsewhere.

## 6. Conclusion

Here the food allergic consumer can check if the food is suitable for them to eat or not by checking the information about the food displayed on the screen. The information will let the consumer know if the food contains any common allergen that most people find harmful. If the consumer is allergic to any other allergen apart from the listed allergens, they can check if it is present in the ingredients used in the dish. If the consumer is very sensitive to food and that they don't want to take any risks, by ordering food elsewhere, they can make their own allergen free food themselves by following up the recipe given in the application. This application can aid both allergic and non allergic consumers in choosing the food they want to eat. It is satisfactory and practical as long as it is used for authentic foods.

## References

- [1] Veronica Rossano, Rosa Lanzilotti, Antonio Cazzolla, Teresa Roselli. Augmented Reality to Support Geometry Learning. IEEE. Volume 8, June 2020.
- [2] Rubaiya Hafiz, Jahidul Hasan, Md. Azizul Hakim. Enhancement of Human Anatomy and Nervous System Learning using Mobile Augmented Reality Application. International Journal of Engineering and Advanced Technology (IJEAT) ISSN: 2249 – 8958. Volume-9 Issue-3, February, 2020.
- [3] Xiuquan Qiao, Pei Ren, Schahram Dustdar, Ling Liu, Huadong Ma, Junliang Chen. Web AR: A promising future for mobile augmented reality- State of the art, challenges and insights. IEEE Trans. In AR, vol.107, no.4, April 2019.
- [4] Eg Su Goh , Mohd Shahrizal Sunar, Ajune Wanis Ismail. 3D Object Manipulation Techniques in Handheld Mobile Augmented Reality Interface: A Review. VOLUME 7, 2019.
- [5] Jibin Yin , Chengyao Fu, Xiangliang Zhang , Tao Liu. Precise Target Selection Techniques in Handheld Augmented Reality Interfaces. VOLUME 7, 2019.
- [6] Swarna Priya RM, Aarthy S L, Gunavathi C, Venkatesh P, Srinivas Koppu. 3d reconstruction of a scene from multiple 2d images. International Journal of Civil Engineering and Technology (IJCIET). Volume 8, Issue 12, December 2017.
- [7] Megan E. Rollo, Tamara Bucher, Shamus P. Smith & Clare E. Collins. ServAR: An augmented reality tool to guide the serving of food. International Journal of Behavioural Nutrition and Physical Activity. Volume 14, Article number: 65 (2017).
- [8] Anuroop Katiyar , Karan Kalra and Chetan Garg. Marker Based Augmented Reality. Advances in Computer Science and Information Technology (ACSIT). Print ISSN: 2393-9907; Online ISSN: 2393-9915; Volume 2, Number 5; April-June, 2015 pp. 441-445.
- [9] Isidro Navarro, Antonio Galindo, David Fonseca. Augmented reality uses in educational research projects: The “Falcones Project”, a case study applying technology in the Humanities framework at high school level. First International Conference on Technological Ecosystems for Enhancing Multiculturality (TEEM'13), 2013.
- [10] Christina A. Roberto, MS, Peter D. Larsen, MPhil, Henry Agnew, BA, Jenny Baik, BA, and Kelly D. Brownwell, PhD. Evaluating the impact of menu labelling on food choices and intake. American journal of public health, 2010.
- [11] Ambeth Kumar.V.D et,al .Enhancement in Footprint Image using Diverse Filtering Technique.Procedia Engineering journal, Volume 8, No.12, 1072-1080, 2012 . [doi:10.1016/j.proeng.2012.01.965]

# APMFT: Anomaly Prediction Model for Financial Transactions Using Learning Methods in Machine Learning and Deep Learning

R. Priyadarshini<sup>a,1</sup>, K. Anuratha<sup>b</sup>, N. Rajendran<sup>c</sup> and S. Sujeetha<sup>d</sup>

<sup>a,c</sup> Assistant Professor, Dept of IT, B.S. AbdurRahman Crescent Institute of Science and Technology, Chennai

<sup>b,d</sup> Assistant Professor, Dept of IT, Sri Sai Ram Institute of Technology, Chennai

**Abstract:** Anomaly is an uncommon and it represents an outlier i.e, a nonconforming case. According to Oxford Dictionary of Mathematics anomaly is defined as an unusual and erroneous observation that usually doesn't follow the general pattern of drawn population. The process of detecting the anomalies is a process of data mining and it aims at finding the data points or patterns that do not adapt with the actual complete pattern of the data. The study on anomaly behavior and its impact has been done on areas such as Network Security, Finance, Healthcare and Earth Sciences etc.,. The proper detection and prediction of anomalies are of great importance as these rare observations may carry significant information. In today's financial world, the enterprise data is digitized and stored in the cloud and so there is a significant need to detect the anomalies in financial data which will help the enterprises to deal with the huge amount of auditing. The corporate and enterprise is conducting audits on large number of ledgers and journal entries. The monitoring of those kinds of audits is performed manually most of the times. There should be proper anomaly detection in the high dimensional data published in the ledger format for auditing purpose. This work aims at analyzing and predicting unusual fraudulent financial transactions by employing few Machine Learning and Deep Learning Methods. Even if any of the anomaly like manipulation or tampering of data detected, such anomalies and errors can be identified and marked with proper proof with the help of the machine learning based algorithms. The accuracy of the prediction is increased by 7% by implementing the proposed prediction models.

**Keywords:** Anomaly detection, Deep Learning, Machine Learning, financial data, neural network model, CNN.

---

<sup>1</sup> Priyadarshini R.,<sup>b</sup> Assistant Professor, Dept of IT, B.S. AbdurRahman Crescent Institute of Science and Technology, Chennai;  
E-mail: rspdarshini@gmail.com

## 1. Introduction

Detecting anomalies is essential in finance sector as this may reveal illegitimate activities such as fraudulent risk, theft of identity, network intrusion which may lead to unsought consequences such as service disruptions and other failures. As the dimension of data is increasing in large scale as there is change in finance environments, growth in digital platforms, it becomes very challenging to detect the unusual activities. Many ideas involving semi-supervised learning, deep learning algorithm and graph based methods to address this challenge in anomaly detection. In sectors like finance, when the data exponentially increases then the methods may not work in realtime and may also time consuming. Multiple industries are witnessing an exponential increase in the availability of streaming large volume of data. Anomaly detection techniques are generally aimed at finding the what is considered as normal and how to differentiate the abnormality from normality.

## 2. Problem Statement

Since the introduction of Digital Transactions, the scammers have found methods to exploit public and use the credit cards, debit cards or digital credentials to have unauthorized access. Fraud has been a stumbling block since the years in domains like Finance, Healthcare, Insurance and several other financial domains. Due to the growth in digital transactions through diverse payment options, such as PhonePe, Google pay, Paytm, etc., there is increase in fraudulent activities also. Since no system is always consistent and there is always an ambiguity. In the proposed system we would like to address few fraudulent transactions such as Embezzlement. To identify these kinds of unusual activities and to stop them from happening again, we have developed a model using various Learning Algorithms and Statistical Methods. The model will be learning from the training data and used for prediction using the previous knowledge and stored patterns.

## 3. Literature Survey

Title	Proposed Techniques / Model	Observations
Rajan G et al. , in their paper Construction of Optimal Portfolio Using Sharpe Index 2018 [1]	Discussed the grouping of securities on shares, bonds and finance market tools. The process of integration of the various assets to get an optimal profit with less financial threat is termed as portfolio construction. They have summarized that the process can be simplified by using Sharpe model to associate the profit in a security to a market index, by adapting CAPM theory which defines the relationship of an asset with its systematic possible threats	The portfolio used 5 securities and its Investment is from 4 % to 43.39 % considering HDFC Bank Ltd. , HDFC Ltd. ICICI Bank Ltd, TCS Ltd. and TATA Motors Ltd with HDFC Bank Ltd with maximum weightage and TCS Ltd with least weightage. The proposed method may not suitable for consistent prediction of security threats financial data as stock market is non-volatile



“The Single Index Model & The Construction Of Optimal Portfolio: A Case Of Banks Listed On Nse India” [2]

Considered ten financial companies from National Stock Exchange and the Bank Price Index was accounted during 2009 and 2013.

Proposed the available options for the investors analysing the returns, risk on investment. We cant accurately analyse and predict as the financial market is not static

#### 4. Proposed Model

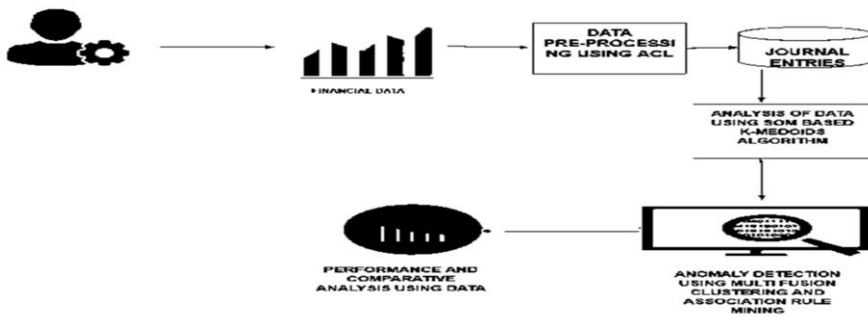


Figure 1. System Architecture

#### 4.1 Modules

##### 4.1.1 Module 1

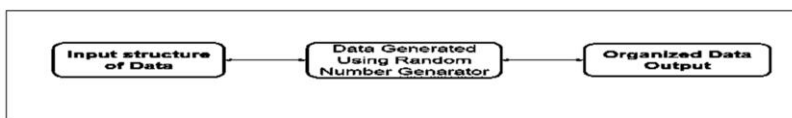


Figure 2. Data Generation and Data Collection

##### 4.1.2 Module 2

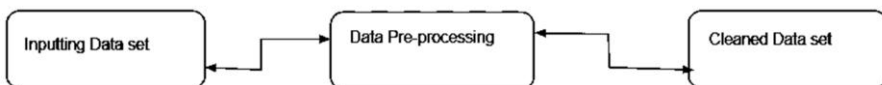


Figure 3. Data Preprocessing

### 4.1.3 Module 3

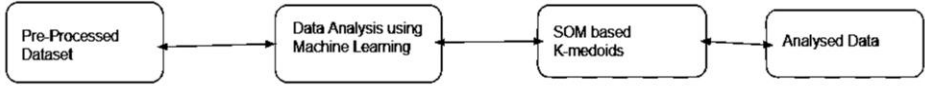


Figure 4. Data Analysis

### 4.1.4 Module 4

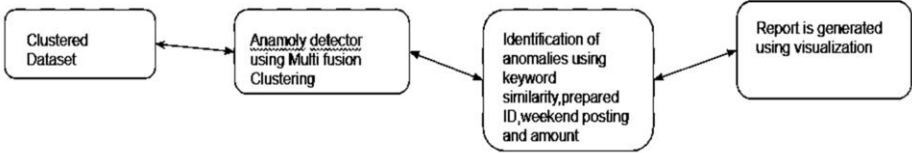


Figure 5. Anomaly Detection In Analysed Data Using Multi Fusion Clustering

## 5. Results And Discussions

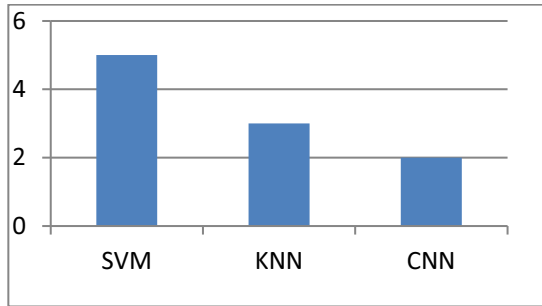


Figure 6. Frequency on right prediction

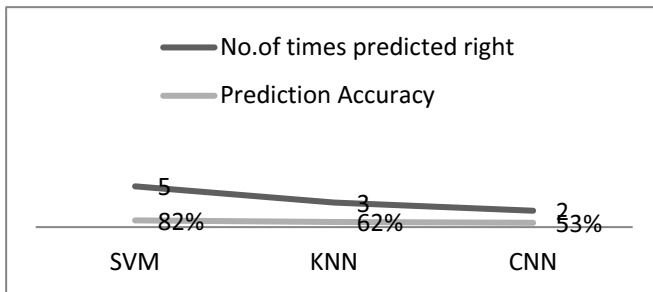


Figure 7. SVM outperforms KNN and CNN

## 6. Conclusion

This paper provided insights on Machine Learning and Deep Learning methods to detect the fraudulent transactions and attempted to find the best method for better prediction. The study identified that for high dimensional data SVM classifier is best suited to predict the unusual financial transactions. We have tried only with the supervised learning methods and it would be better if the classifiers are built using unsupervised learning methods as the financial data are inconsistent and volatile in nature.

## References

- [1] Chakraborty, Subhdeep& Patel, Ajay. (2018), Construction of Optimal Portfolio Using Sharpe's Single Index Model and Markowitz Model An Empirical Study on Nifty, 50 Stock. 5. 86-103.
- [2] Singh, Saurabh&Gautam, Jayant. (2014), The single index model & the construction of optimal portfolio: A case of banks listed on NSE India, Risk Governance and Control: Financial Markets & Institutions. 4. 10.22495/rgcv4i2c1art3.
- [3] Marisetty, Nagendra. (2012), Construction of Optimal Portfolio using Sharpe Index Model, SSRN Electronic Journal. 10.2139/ssrn.3456697.
- [4] Ambeth Kumar.V.D et,al, Enhancement in Footprint Image using Diverse Filtering Technique. Procedia Engineering journal, Volume 8, No.12, 1072-1080, 2012 . [doi:10.1016/j.proeng.2012.01.965]
- [5] Ambeth Kumar.V.D et.al., .Performance Improvement Using an Automation System for Segmentation of Multiple Parametric Features Based on Human Footprint. for the Journal of Electrical Engineering & Technology , vol. 10, no. 4, pp.1815-1821 , 2015. [http://dx.doi.org/10.5370/JEET.2015.10.4.1815]
- [6] Ambeth Kumar.V.D et.al. A Survey on Face Recognition in Video Surveillance. Lecturer Notes on Computational and Mechanism, Vol. 30, pp: 699-708, 2019
- [7] Ambeth Kumar.V.D .Precautionary measures for accidents due to mobile phone using IOT. Clinical eHealth, Volume 1, Issue 1, March 2018, Pages 30-35.
- [8] K. Sabarinathan et.al ., “ Machine Maintenance Using Augmented Reality”, 3rd International Conference on Communication and Electronics Systems (ICCES), 2018. (DOI: 10.1109/CESYS.2018.8723900)
- [9] R. Subha Shini et.al., “ Recurrent Neural Network based Text Summarization Techniques by Word Sequence Generation”,IEEE International Conference on Inventive Computation Technologies (ICICT), 2021, DOI: 10.1109/ICICT50816.2021.9358764

# Enhanced and Efficient Carry Select Adder with Minimal Delay

G. Srividhya<sup>a</sup>, T. Sivasakthi<sup>b</sup>, R. Srivarshini<sup>b</sup>, P. Varshaa<sup>b</sup> and S. Vijayalakshmi<sup>b</sup>  
<sup>a</sup>*Assistant Professor, Dept of ECE, Panimalar Engineering College, Chennai, India*  
<sup>b</sup>*Dept of ECE, Panimalar Engineering College, Chennai, India*

**Abstract:** In today's digital world, Arithmetic computations have been evolved as a core factor in digital signal processors, micro-controllers, and systems using arithmetic and logical operations such as adders, multipliers, image processors, and signal processors. One of the elements that play an important role in performing arithmetic calculations is an adder. Among many adders, the Carry Select Adder produces less propagation delay. However, there may be an increased delay, power consumption, and area required in the case of a normal Carry Select Adder. To overcome the mentioned drawbacks, an improved model of Carry Select Adder has been designed that uses Binary to Excess – 1 Converter. Instead of using multiple blocks of Ripple Carry Adders (RCAs), it is efficient and effective if one of the blocks is replaced with Binary to Excess – 1 Converter. As a result, we can achieve a high speed adder with minimal delay, minimal power, and reduced area.

**Keywords:** Bit enhanced, Minimal Delay, Carry Select Adder (CSLA) and Binary to Excess – 1 Converter (BEC).

## 1. Introduction

VLSI circuits with high speed and minimal delay are a core part of this technological world. The performance and efficiency of a circuit are in the hands of adders and multipliers which is the deciding authority in VLSI design [1-4]. In carry select adder there is a trade-off between ripple carry adder and carry look ahead adder in area and delay [5]. Low power and Minimal delay circuits play a vital role in many VLSI-based systems, Digital Signal processors, Generic processors, and Complex Arithmetic and Logical units. The role of adders has become inevitable in every digital circuit. An Adder that has been widely used for its fast processing feature is the Carry Select Adder (CSLA). Even though many works have been done on Carry Select Adder, yet a minimal effort has been taken to enhance it by bit-wise, and to reduce its delay. In keeping this as a central theme, a proposed carry select adder has been modeled which operates on 256 and 512 bits of binary data with minimal delay and providing efficient results at a faster rate. The binary addition is the most fundamental arithmetic operation that is most often used. In maximum designs, add end as play a critical role and operating speed. [6].

---

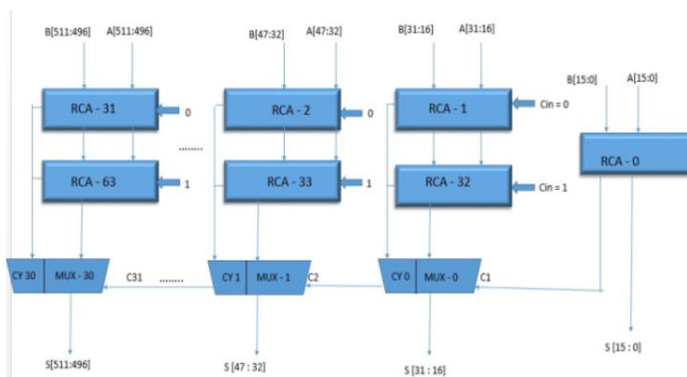
<sup>1</sup>G. Srividhya, Assistant Professor, Dept of ECE, Panimalar Engineering College, Chennai, India.  
 Email: srividhya108@gmail.com

Carry selection adder is one of the quick adders because it overcomes the problem of transport propagation by having two probable carry values. (i.e., both  $c_{in}=0$  &  $c_{in}=1$ ). Carry select adder uses ripple carry adders and multiplexer. Hence propagation delay comes into consideration. In ripple carry adder, carry propagation causes delay. To increase the efficiency of an adder, a new approach is presented in this paper. To overcome this delay a code converter is used. The code converter unit reduces delay, area and power utilization. Hence we can achieve greater speed.

**2. Existing Carry Select Adder (CSLA)**

Ripple Carry Adder (RCA) delivers the most compact design, but takes more time to calculate. Time-critical apps utilize Carry Look-ahead. [7] A Conventional Carry Select Adder (CSLA) has two Ripple Carry Adders (RCAs) and Multiplexers is shown in figure 1. For the addition of two n-bit numbers, two RCAs are multiplexed together and addition is performed. For example in the case of adding two 4-bit numbers, two 4-bit ripple carry adders perform the addition with carry-in being 0 at one time and carry-in being 1 at the other time. After the carry-in is known by calculating addition, correct sum and multiplexer selects the correct carry. The performance of large digital circuits is dependent upon the speed of the circuits that make up the different functional units. Adders are among the most widely used. [8].The bit number given to the Carry Select blocks can either be static or dynamic. For static case, the computational delay is of the order of  $O(\sqrt{N})$ , where N refers to the number of bits provided at the input to a Carry Select Block. For dynamic case, the delay can be calculated by the number of multiplexer chains. As a result, the delay varies with respect to the number of multiplexer blocks utilized.

In carry select adder we have two ripple carry adders and multiplexers. Adding n bit of two numbers is done by two adders (RCA) one with  $C_{in}=0$  and the other with  $C_{in}=1$ . Based on the carry that propagates at each stage from one bit to the other bit, the multiplexer selects values between two carry values. With different adders, Ripple Carry Adder is straightforward to layout however consumes more postprocess for the reason that convey little bit of closing complete adder is legitimate simplest after the joint propagation delay of all complete adder cascaded [9]



**Figure 1.** Existing 512 Bit CSLA

### 3. Enhanced Carry Select Adder (E-CSLA)

The designed new model of Carry Select Adder in figure2 is enhanced both in terms of Number of bits that it can process as well as the delay that it encounters during the computation. The proposed adder is being capable of processing 256 and 512 bits of data, one at a time. Despite the rise in bit number, computation can be done with a vast binary data compared with normal carry select adders. As a result, the proposed adder is more effective in doing computations in processors ranging from generic to Digital Signal processors. [Bit enhanced].The delay is significantly reduced in this method. Because of BEC the area occupied by this enhanced CSLA is greatly reduced. The speed is also increased which makes the arithmetic calculations faster. Hence this enhanced approach can be utilizes in many applications.

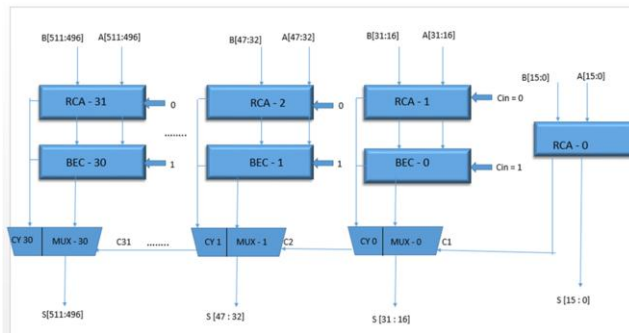


Figure 2.Enhanced 512 Bit CSLA (E-CSLA)

This adder varies from existing Carry Select Adder by using Binary to Excess-1 Converter (BEC) instead of a Ripple Carry Adder (RCA). Because of using BEC, one can effectively reduce the propagation delay and as well reducing the computational time. As a result the area that it uses while fabricating it to an IC in processors is significantly reduced to an extent. The RTL schematic in figure3 of the enhanced CSLA is given below.

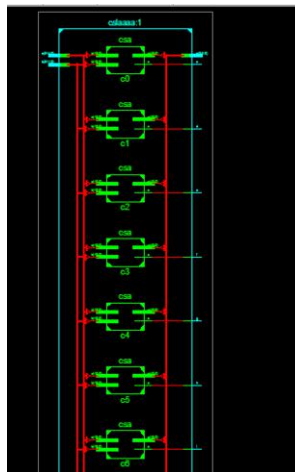


Figure 3.RTL schematic

#### 4. Comparisons

From the table 1, it is obvious that the proposed Carry Select Adder ensures a minimal delay compared with other adder circuits.

**Table 1.** Delay Comparison Table

VARIOUS TYPES OF ADDERS	DELAY (in ns)
Ripple Carry Adder(RCA)	28.741 ns
Carry Look Ahead Adder(CLA)	24.196 ns
Carry Select Adder Without BEC(CSLA)	20.035 ns
Carry Select Adder With BEC(E-CSLA)	18.689ns

In addition to the proposed work, research based on comparisons of few existing adders is also undertaken. The various existing adders are already elaborated in the papers [10]. A few adders are taken and simulated with the help of Xilinx version 14.7. The comparisons are tabulated in the table 1. The listed delay is for 512 bit. Our proposed work is for 16, 32, 64, 128, 256 and 512 bit. Although the number of bits increased in a wide scale we achieve greater speed, low power utilization, low area and minimal delay in our work.

#### 5. Future Enhancements

This modified approach can also be enhanced to many bits. Also, this work can be implemented with image enhancement for digital signal processing, and it can be achieved with the help of MATLAB. The image enhancement can also be a successful implementation of this proposed work. Besides image enhancement FIR filters, integration and some mathematical operations can be carried out which will have a great scope in emerging digital industry. In the rapid growing digital technology image enhancement will have numerous application by using this proposed system of design of an adder with binary to excess 1 converter unit.

#### 6. Results of Simulation and Discussions

The existing design and the new designed model for various sets of inputs are coded and executed with the help of Xilinx tool version 14.7. the test bench program for different sets of inputs are executed and verified. The below figure 4 and 5 display the simulation results of the modified adder. The comparison of adders also are simulated and verified for their delay and other parameters check. Thus the simulation results and

its RTL schematic diagram are illustrated below. Thus our proposed modified adder achieves less delay with greater speed.

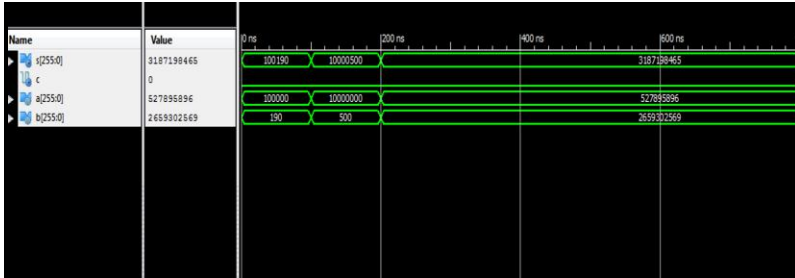


Figure 4. Simulation Result of 256 Bit

## 7. Conclusion

Thus the new designed system of Carry Select Adder offers minimal Delay with increased number of bits, Binary to Excess-1 Converter for reducing the computational time. Therefore this adder occupies lesser area and utilizes lesser power compared with Conventional Carry Select Adder. This design is implemented in FPGA kit and simulated in Xilinx software. This new designed approach can be used in many applications like arithmetic calculations for speedier results.

## References

- [1] Akila.M,Gowribalaand.C,MaflinShaby.S (2016).Implementation of High Speed Vedic Multiplier using Modified Adder', International Conference on Communication and Signal Processing, pp. 2244-2248.
- [2] Ram Gavali.K and P. Kadam (2016).VLSI Design of High Speed Vedic Multiplier for FPGA implementation.2nd IEEE InternationalConference on Engineering and Technology.
- [3] Raju.R and S. Veerakumar (2016).Design and Implementation of Low power and High Performance Vedic Multiplier. InternationalConference on Communication and Signal Processing, pp. 0601- 0605.
- [4] Challa Ram.G, Sudha Rani.D, Y. Rama Lakshmana and K. BalaSindhuri (2016).Area Efficient Modified Vedic Multiplier.International Conference on Circuit, Power and Computing Technologies.
- [5] O.J. Bedrij (1962) .Carry Select Adder. IRE Transactions on Electronic Computer, p.p. 340-346.
- [6] Kumar.P and Kiran.M (2013) 'Design of Optimal Fast Adder', International Conference on Advanced Computing and Communications Systems (ICACCS), p.p. 1-4.
- [7] Saxena, P. (2015). Design of low power and high speed Carry Select Adder using Brent Kung adder. 2015 International Conference on VLSI Systems, Architecture, Technology and Applications (VLSI-SATA)
- [8] Shivani Parmar and Kirat Pal Singh.Design of High Speed Hybrid Carry Select Adder.IEEE's 3rd International Advance Computing Conference (IACC) Ghaziabad, ISBN: 978-1-4673-4527-9,22-23 February 2013.
- [9] R. Suganya and D. Meganathan (2015).High Performance VLSI Adders.International Conference on Signal Processing,Communication and Networking (ICSCN).2019 6th International Conference on Signal Processing and Integrated Networks (SPIN) 561
- [10] Saini.J, agarwal.S, kansal.A (2015), 'performance analysis and comparisons of digital adders'.



# Customer Loan Approval Prediction Using Logistic Regression

Mahankali Gopinath<sup>a,1</sup> K. Srinivas Shankar Maheep<sup>b</sup> and R. Sethuraman<sup>c</sup>

<sup>a,b</sup>UG Student, Dept of CSE, Sathyabama Institute of Science and Technology, Chennai, India

<sup>c</sup> Assistant Professor, Dept of CSE, Sathyabama Institute of Science and Technology, Chennai, India

**Abstract:** Banking Sector contains loan where it is a process of lending or borrowing a sum of money by one or more individuals, organizations, etc. from Banks. The Person who lends that money from respective financier incurs a debt, and he is responsible to pay back the money with the Interest decided by Bank within a certain period. Generally what Bank's look into before applying for a loan is Credit History, Credit loss and Income of Applicant. So basically, loans play a major role regarding Income for Bank. Due to rapid urban development people who are applying for loans got increased rapidly. Therefore, finding the applicant to whom loan can be approved become a complexed process. In this paper, we want to predict the loan eligibility based on details of the customer. Fields that required are Matrimonial Status, Income, Education, Loan Amount, Credit History and other income sources of Applicant dependants. To predict the status, we will use Logistic Regression to spot the eligible applicants so bank will engage with them for granting loans to those people who can payback in a given time.

**Keywords:** Loan, Exploratory Data Analysis, Prediction, Logistic Regression

## 1. Introduction

The banking industry plays a significant role in present mostly in developing countries where money is usually required for all of them, so they will increase their market to capital value by gaining profits. Banks allow their customers to save lots of money in individual accounts. So, then Banks allow to lend money to business people or others who can utilize it for his or her capital growth and meet their Business requirements, and payback to the bank within a specific period of your time including Interest amount. So, interest is the profit gained by the banks by giving loans to folks that are in need. But Banks are worried about whether the person whose loan got granted will be ready to payback loan amount or not. So as to predict it, they basically inspect things associated with applicant like Credit score, Applicant Income.

---

<sup>1</sup>Mahankali Gopinath, UG Scholar, Dept of CSE, Sathyabama Institute of Science and Technology, India.  
Email: mahankaligopinath382@gmail.com

Credit Score. Here the credit score plays the key role in information given by the customer. In most scenarios Credit score is required for Loan sanction. If the applicant didn't payback his loan amount, then eventually his credit score will automatically get decreased. Giving Loans to people is one among the most business strategies for pretty much every bank. Banks will get most of the profits from the loan within the types of Interest. The most goal of Bank authorities is to grant loans to trustworthy people, so they'll pay back on the deadline comes. In recent times, banks are approving loans at their customers after a step-by-step procedure, but there's still no guarantee that the applicant's loan was granted or not. To approve loan, banks will undergo to estimate risk involved within the application, which is important for them as they cannot lend money to those that cannot afford to pay back in time which affects their economic status during this huge competitive market. So, we've got collected Dataset from the Kaggle contains loan applicant's details contains various fields like Gender, Applicant Income, Credit history etc.

After doing an Exploratory Data analysis on these data sets, we have discovered that probabilities of getting Loan granted are higher for applicants who have credit history equals to '1' with greater applicant income, with Education level mostly graduated and eventually who lives urban areas with properties. So, we'd like a model supported Fields Credit history, Education and Gender of Applicant. This model developed using Logistic Regression. we'll use this model to check with another data set and results obtained are stored in other file with Predicted Approval status as 'Yes' or 'No'. We have chosen Logistic Regression because it gives an Accuracy Rate of 80.945% approximately.

## **2. Literature Review**

In Somayyeh. Z et al [1] a model was proposed for predicting and identifying the right applicants who have applied for loan. So here Decision Tree technique is implemented to estimate the traits where accuracy rate is not much appreciable. In Sudhamathy G et al [2], This paper aims to build a model. It was based on decision tree where classification is used. It also uses the functions in the R-Package. Before preparing the model, the data is synchronized, made it ready to deliver effective results. The model prepared is used for predict using the dataset and the results shows the accuracy. In Dileep. B et al [3], Data analysis was done by figuring out techniques like Bayes classification, Decision Tree, Logistic Regression, K means algorithm, Neural Network Techniques, Perception model are combined in this model. The results in this work show the overall effective performance is very good. In Allen et al [4], The authors get to know that the economic effects of small business with credit scoring with both too high mean prices and also with more risk levels for small business. Also they find that a) banking specific and industry-wide learning curves are crucial b) These effects differ for banks that follow "rules" and c) These effects differ to people with slightly larger credits. In Altman, E. I. [5], This paper provides some empirical results of a study considering financial ratios as predictors of Japanese corporate failure. In contrast, the model proposed in this is independent of industry zone and size. This study shows that the model can predict bankruptcy with approximately 86.14% accuracy of industry and size. In J.H. Aboobyda et al [6], In this paper, a model was developed for categorize loan risk in the banking industry. It has been implemented by using data mining algorithms. The results make a comparison

between these three algorithms was conducted. J48 was best among the three based on accurate results. In A.B. Hussain et al [7], Here Two separate data mining models were created calculating the credit score that can be useful in making decisions of granting loans for the banks in Jordan residents. By the accuracy rate, the regression based model is found to perform more than the other function model. In T. Harris [8], This work tries to see the probability of default as a tool to live credit risk in an exceedingly Tunisian bank. A score calculable model was built using logistic regression, and computer science techniques. Thus, within the Tunisia context, this model is worth implementing in banking institutions so as to boost their credit risk management measures to watch and control credit. In Charles Kwofie et al [9], This study shows the good performance of logistic regression in predicting the probability of data provided by a microfinance company. The variability within the response variable within the logistic regression is not good enough.

### 3. Proposed Work

Python has could be a good area for data analytical which helps us in analysing the data with better models in data science. The libraries in python make the prediction for loan data and results with multiple terms considering all properties of the customer in terms of prediction. Logistic Regression is deployed to create the model and used to get the output by predicting results accurately. Credit history could be one best criteria that helps the banks and loan approvers to make its process for credit granting decisions For predicting results, we have collected Data sets in Kaggle. In order to build this model, we will import some python packages which will be used to analyse the data sets. They are NumPy, Pandas, Matplotlib and scikit-learn Libraries. All these libraries are available in Python.

#### 3.1 Dataset Description

There are two Datasets which are required to build this model. 1) Train Dataset and 2) Test Dataset. The Test dataset contains list of customers applied for loan. By using Train Dataset, we can train the model and use it to predict loan status for Test dataset. The dataset is in CSV format. In python, Pandas is used to read the dataset. Refer the below table for field variables of the dataset.

**Table 1.** Data Description

Variable	Description
Loan_ID	Unique Loan ID
Gender	Male/ Female
Married	Applicant Married(Y/N)
Dependents	Number of dependents
Education	Graduate/Under Graduate
Self-Employed	Self Employed (Y/N)
Applicant_Income	Applicant Income
Coapplicant_Income	Co Applicant Income
Loan_Amount	Loan Amount in thousands
Loan_Amount_Term	Term in Months
Credit_History	Credit History meets guidelines
Property_Area	Urban/ Rural
Loan_Status	Loan Approved (Y/N)

### 3.2 System Requirements

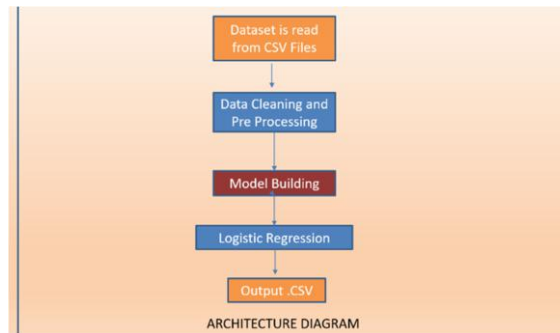
#### Software Requirements

- Windows XP, Windows 7, Windows 10
  - Python 3.5 Mozilla Firefox(or any browser)
  - Jupyter Notebook IDLE.
- #### Hardware Requirements
- Minimum HDD: 20 GB
  - Random Access Memory: 512 MB
  - I3 processor-based computer or higher.

## 4. Software Methodology

After reading the dataset, we will implement Exploratory Data Analysis to understand and find out the outliers in the dataset.

### 4.1 Block Diagram



**Figure 1.** Block Diagram

In the above diagram, It shows what are the steps involved in building this model.

### 4.2 Modules

The Customer Loan Approval Prediction Model has mainly 3 modules. They are

- Reading and Cleaning Dataset.
- Model Building.
- Testing Dataset with Model

#### 4.2.1 Reading and Cleaning Dataset

We need to import Pandas, NumPy, and scikit-learn libraries and use them to process the information. Reading both training and testing dataset using Pandas. By Using head () function, we are going to be ready to see the first 10 rows of the dataset so that we'll have a clear picture of what fields does dataset contains in it. After then we will store the length of rows and columns within the dataset. we'd like to grasp the varied features and columns of the dataset Understanding Distribution of Numerical Variables like Applicant Income and Loan The amount may be done by using Boxplot to know and

finding the outliers of the Dataset fields. But there are more graduates with getting high incomes, which makes them outliers in this situation. Now it's time to understanding distribution of Categorical Variables. By making a Cross table with both Credit History and Loan Amount Fields we will see that Loans Approved within the Train Data set are more with applicants having credit history equals 1. Then we are going to write a function to search out the proportion of applicants whose loans are approved with credit history adequate to 1 and it shows more than 79% of individuals have gotten loans with a Credit history of 1.

In Boxplot of Loan Amount by Gender. Outliers are present in Male Gender than compared to female. Now we are going to move forward and understand outliers in an exceedingly better way within the next module to create the model. Outliers are slightly having extreme values when compared tonormal ones in the dataset we

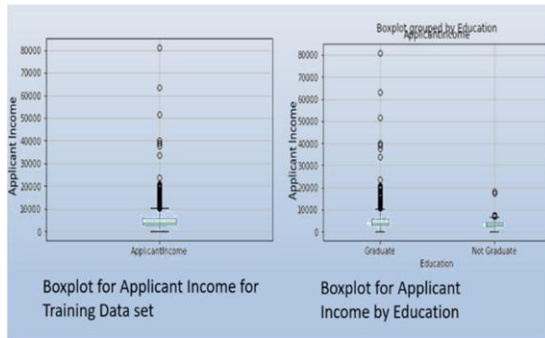


Figure2. Box Plot for Applicant Income by Education

Box plot for Applicant Income by Education shows that there are a greater number of graduates getting higher incomes can be Outliers.

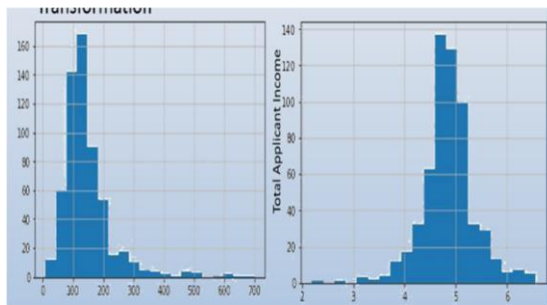


Figure3. Boxplot for Applicant Income after Log Transformation

The extreme values getting here are can happen in real, i.e., few people might apply for loans with high figures due to needs. So instead of looking them as outliers, we tried a log transformation to nullify those outliers effect. Also, we combine both Applicant and Co Applicant Income for better results. Also, we need to fill missing values for Data preparation for Model Building in next modules. We generally fill the missing values using pandas by Null values.

### 4.2.2 Model Building

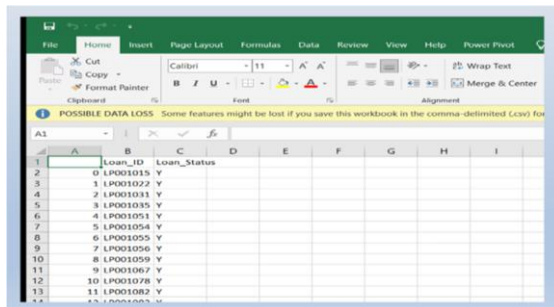
After converting all our fields which contain categorical variables into numeric values as scikit-learn all inputs remain to be numeric. Here we can see all the variables in the dataset are in numeric Data type. Now we will build Generic Classification Function by importing scikit learn module and accessing performance. By Perform k-fold cross-validation with 5 folds. Training the algorithm using target and predictors. Fit the model again so that it can be referred outside the function by adding Accuracy rate and cross validation score. Look at the summary of missing values of both datasets and fill them with Null values for both categorical and numeric variables. Now all the variables are converted to numeric for processing in model. Now we create a new column named as Total Income by adding both Applicant Income and Co Applicant Income and create label encoders for them. We have used Logistic Regression in building the mode Logistic Regression is one of the popular algorithms that belongs to Supervised Learning Techniques. In this algorithm, the result must lie between 0 and 1 which means Yes or No (True/False). So, it was mainly used for solving classification-based problems. It predicts only two values, so it makes our model job very accurate and give good results as we expected.

- Credit history.
- Applicants having High Applicant income.
- Applicants with High academic degree.
- Applicants having Properties in urban territory.

So, we made our model with CreditHistory, Education & Gender.

### 4.2.3 Testing Dataset with Model

For this Model, the Accuracy Rate is 80.945% with Cross Validation Score of 80.946% which is best value when compared to recent models based on other Machine Learning Models. Output CSV file is stored in local storage with fields Unique Loan ID with predicted Loan Approval Status as Yes or No. By using this results Banks can go ahead and complete the loan approval process for right applicants.



	A	B	C	D	E	F	G	H	I
1		Loan_ID	Loan_Status						
2	0	LP001015	Y						
3	1	LP001022	V						
4	2	LP001031	V						
5	3	LP001035	V						
6	4	LP001051	V						
7	5	LP001054	V						
8	6	LP001055	V						
9	7	LP001056	V						
10	8	LP001059	V						
11	9	LP001067	V						
12	10	LP001078	V						
13	11	LP001082	V						
14									

Figure 4: Output CSV File Screenshot

## 5. Conclusion and Future Scope

Finally, by using logistic regression model we can predict whether the loan can be approved or not. so as to implement this various input variables were accustomed to get the output. Whenever a program takes the computer file it returns the output within the type of binary i.e., either 0 or 1. If the output is 0 then '0' is displayed and it indicates that the loan is not approved. If the output is 1 then '1' is displayed and it indicates that the loan is approved. This model may help the banking system to take right decision in approving or rejecting Loan applicants in less time.

## References

- [1] Z. Somayyeh, and M. Abdolkarim, Natural Customer Ranking of Banks in Terms of Credit Risk by Using Data Mining A Case Study: Branches of Mellat Bank of Iran, *Jurnal UMP Social Sciences and Technology Management*, vol. 3, no. 2, pp. 307–316, 2015.
- [2] Sudhamathy G and Jothi Venkateswara, Analytics Using R for Predicting Credit Defaulters, *IEEE international conference on advances in computer applications (ICACA)*, 978-1-5090-3770-4, 2016.
- [3] Dileep B. Desai, Dr. R.V.Kulkarni ,A Review: Application of Data Mining Tools in CRM for Selected Banks, (*IJCSIT*) *International Journal of Computer Science and Information Technologies*, Vol. 4 (2), 2013, 199 – 201.
- [4] Allen, N., Berger, W., Scott, F., & Nathan, H. M. (2002). Credit Scoring and the Availability, Price, and Risk of Small Business Credit. FRB of Atlanta Working Paper No. 2002-6, FEDS Working Paper No. 2002-26.
- [5] Altman, E. I. (1968). Financial Ratios, Discriminant Analysis and the Prediction of Corporate Bankruptcy. *The Journal of Finance*, 23(4), 589-609.
- [6] J.H. Aboobyda, and M.A. Tarig, ,Developing Prediction Model Of Loan Risk In Banks Using Data Mining, *Machine Learning and Applications: An International Journal (MLAIJ)*, vol. 3, no.1, pp. 1–9, 2016.
- [7] Hussain.A.B, and Shorouq F.K.E., Credit risk assessment model for Jordanian commercial banks: Neural scoring approach, *Review of Development Finance*, Elsevier, vol. 4, pp. 20–28, 2014.
- [8] T.Harris, Quantitative credit risk assessment using support vector machines: Broadversus Narrow default definitions, *Expert Systems with Applications*, vol. 40, pp.4404– 4413, 2013.
- [9] Kwofie, Charles & Owusu-Ansah, Caleb &Boadi, Caleb. (2015). Predicting the Probability of Loan-Default: An Application of Binary Logistic Regression. *Research Journal of Mathematics and Statistics*. 7. 46-52. 10.19026/rjms.7.2206.

# Smart Security System Using IoT, Face Recognition and Processor to Processor Communication

Indhuja G <sup>a,1</sup>, Aashika V<sup>b</sup>, Anusha K<sup>b</sup>, Dhivya S<sup>b</sup>, and Meha Soman S<sup>c</sup>  
<sup>a,b</sup>UG Scholars, Dept of ECE, Panimalar engineering College, Chennai, India  
<sup>c</sup>Assistant Professor, Dept of ECE, Panimalar engineering College, Chennai, India

**Abstract:** In the present world the security of the home, banks, shops, etc., are the prime concerns. The traditional security such as Closed-Circuit Television (CCTV) cameras are very easy to break and lead to theft. And moreover, the installation cost of the security systems is costlier. To overcome these problems, we are presenting Internet of Things (IoT) based solution where we can setup a smart security system. In this paper, we are proposing the system with the help of face detection and face recognition algorithms to secure our home which gives us the facility of entire surveillance of our buildings remotely and take appropriate action if anything goes wrong. The Camera Serial Interface (CSI) is attached to the Raspberry PI which detects presence of person using Face detection and recognition algorithms. The multiple Raspberry PIs attached in different areas of our buildings are connected to the main Raspberry PI which acts as hub module. If the person is identified as unknown, the information is sent to Hub module which in turn sends the alert message and live video streaming to the user using an app which we developed.

**Keywords:** Face recognition, SSD algorithm, Mobile face net algorithm, Face detection, Native app development, IOT, Smart security system.

## 1. Introduction:

The home automation is being increasing rapidly in recent years due to considerable cost and simplicity through smartphones connectivity. In this proposed system, we will arm our home with multiple Raspberry Pis that communicate among themselves to accomplish a common goal. Because of lack of flexibility of commercially available systems, we bring in Raspberry Pis to the rescue [2]. A mobile application is developed using react native to enable live streaming and options are given for the user such as alert police, lock door or ignore when an unknown trespasser enters the property [1].

---

<sup>1</sup>Indhuja G, UG Scholars, Department Of ECE, Panimalar engineering College, Chennai, India.  
Email:indhulavanya68@gmail.com



The olden methods of automation systems had been practiced to every single device which was controlled remotely [6]. The situations such as not remembering to switch off the lights or fans before we go away didn't require to drive back to home because the most systems have far-off accessing abilities by just controlling that equipment on computer or smart gadgets in a few seconds [1]. The threats of incursion could be reduced by smart security system incorporated with the above discussed abilities to notify us instantly if something strange happens. Related work is illustrated in Section II, Methodology is proposed in section III, Section IV Conclusion.

## 2. Related works

### 2.1 3-DimensionalDeconvolutionalNetwork

In this paper, for demonstrating knowledge of high-measurements of video data, middle and low-level features were acquired from their proposed 3 Dimensional-Deconvolutional Network (3D-DN) [1]. In, under a scattered confinement, the video stills had been segmented into spatiotemporal in an unsupervised method [4]. It recognized human actions in multiple downstream machine learning goals that used by the high-level representation of the input data [4].

### 2.2 Dynamic Range-Doppler Trajectory & Radar-basedhumangait

The frequency-modulated continuous-wave (FMCW) was used to predict Doppler trajectory (DRDT) system [3]. The micro-doppler (m-d) for the torso and limbs stated that it improved their distinctive Joint Time–Frequency (JTF) features by employing the Short-Time Fourier Transforms (STFTS) [1]. This produces very poor results in accuracy that can't be used for real time implementation. Our proposed work extracted improved features of torso and limbs and accomplished efficient feature fusion [6].

In the existing system, for demonstrating high-measurements of video data, the middle and low-level features were acquired from their proposed a new 3DDN [4]. The video stills had been segmented into spatiotemporal in an unsupervised method [2]. The disadvantage is that the 3DDN models gives low- and middle- level features of video clips. The number of hidden layers and feature maps in 3DDN would lead to improper results [1].

## 3. Proposed Work:

The home automation has been increasingly used in recent years due to the rapid usage of smartphones [3]. To save money, homeowners go with the basic packages for securing their homes. But culprits can find any unprotected entry point to home if you are only installing security system to front and backdoors [1]. Our interoperable system is involved with many Raspberry Pis that communicate among themselves to accomplish a common goal, four options are given to the user to alert user by predicting the presence of unknown person [4]. In this work, we use Python for programming our system because Raspberry Pi depends on Python as its primary

language [1]. Visual Studio (VS) was used platform for our work because VS is an integrated development environment that combines the source code editor with developer tooling [2]. The following shows the block diagram (Fig.1) and (Fig.2) shows the flowchart of our proposed system.

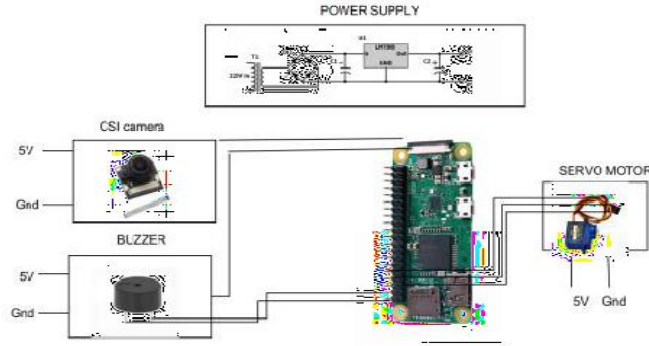


Figure 1. Block Diagram

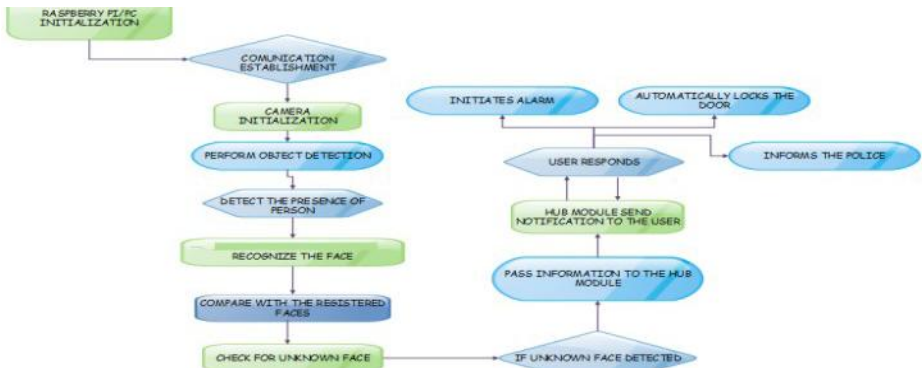


Figure 2. Flow Chart

### 3.1 Modules:

#### 3.1.1 Object Detection Module

To detect objects, SSD (Single Shot MultiBox Detector) algorithm is used. It's faster than Faster Region Based Convolutional Neural Networks (RCNN). The framework map size was reduced by Convolutional Neural Network (CNN) network and increases deepness when it is going to the deeper layers. The larger recipient fields were covered by the deep layers that estimates to larger objects, while the smaller recipient fields were covered by the shallow layers which estimates to minor objects.

#### 3.1.2 Face Detection Module

To detect the faces in low-power computing devices such as ARM, the "Ultra-Light-Fast-Generic-Face-Detector" has been used which is competent to both iOS and Android phones including personal computers (PCs). Detecting human faces in digital format is the beginning step. The input resoluteness of 320×240 is about only 90 to 109

MFlops in terms of model calculation. For working better in different application situations at 320x240 and 640x480 input propositions, it provides pre-instructing models using wider face instructions.

### 3.1.3 Face Recognition Module

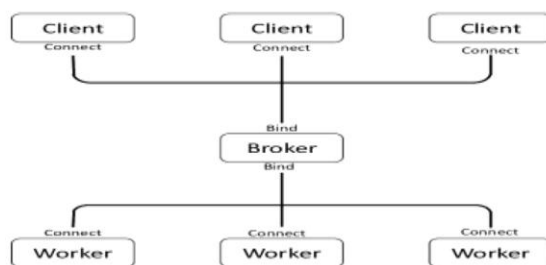
For recognizing the face, we use mobile face net. In the wild text file(LFW) to label faces had 99.28 percent accuracy and in the AgeDB text file to distinguish the faces had 93.05 percent accuracy. It takes only few milli seconds to execute and give results on processors using in mobile phones and uses lower than a million frameworks. This accuracy was 2 times the actual speedup over MobileNetV2. For verifying face, it accomplished improved efficiency than the mobile CNNs. In the below table, the detailed structure is discussed,

**Table1.** Mobile Face Net architecture

Input	Operator	<i>t</i>	<i>c</i>	<i>n</i>	<i>s</i>
$112^2 \times 3$	conv3x3	-	64	1	2
$56^2 \times 64$	depthwise conv3x3	-	64	1	1
$56^2 \times 64$	bottleneck	2	64	5	2
$28^2 \times 64$	bottleneck	4	128	1	2
$14^2 \times 128$	bottleneck	2	128	6	1
$14^2 \times 128$	bottleneck	4	128	1	2
$7^2 \times 128$	bottleneck	2	128	2	1
$7^2 \times 128$	conv1x1	-	512	1	1
$7^2 \times 512$	linear GDConv7x7	-	512	1	1
$1^2 \times 512$	linear conv1x1	-	128	1	1

### 3.1.4 Image ZMQ For Pi To Pi Communication

Image ZMQ is used for transmitting the frames between the client and the server. ImageZMQ has been easy to transport images. Image ZMQ is used for video streaming with OpenCV. For performing the complicated image refining, the images have sent to the central Raspberry Pi via image ZMQ. The two different ZMQ messaging patterns such as REQUEST/REPEAT or PUBLISH/SUBSCRIBE are accepted by this method.



**Figure 3.** Overview architecture of ZMQ

### 3.1.5 MobileApp Module

React native has used for developing the mobile application. It was a framework that builds UI components to build the JavaScript code. To develop a mobile application, it includes a set of components for both iOS and Android platforms. It was good solution

for high-quality apps in a short time with the same performance and user-experience that native apps issue. In this, Android Studio was used for developing mobile app environment.

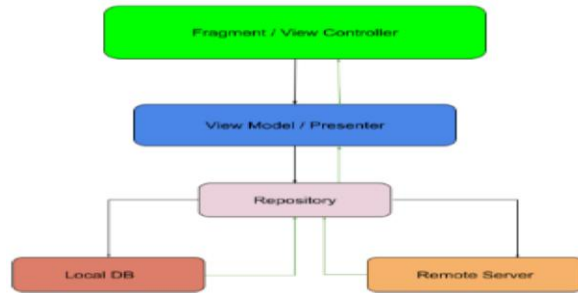


Figure.4. Mobile App Development

#### 4. Results and discussions

Thus, security system with an application is developed based on the proposed algorithms. Initially, it detects the presence of a person in front of the camera. Then, the face is recognized based on the proposed algorithms and compared with the registered faces in data base. If the face is identified as unknown person, then the information containing the image of the unknown person is sent to the hub module which in turn sends the received information as alert message using the app we developed. If the user doesn't respond for a period of time, the alarm is initiated automatically and if the gate is not closed by the user, then using servo meter the gate is closed automatically.

#### 5. Conclusion

Thus, this proposed system provides entire home surveillance using processor to processor communication. This proposed system is mainly used in home for security purpose which helps in saving people properties and money as well as automates the records which helps to punish the thief. It is accessible by the user from anywhere through the app we developed. This can also be implemented in banks, shops, etc...

#### References

- [1] 3-D Deconvolutional Networks for the Unsupervised Representation Learning of Human Motions, Chun-YangZhang,Yong-YiXiao,Jin-ChengLin, C. L. Philip Chen ,Fellow, IEEE, WenxiLiu,andYu-Hong Tong [2020]
- [2] PrivHome:Privacy Preserving Authenticated Communication in Smart Home Environment, Geong SenPoh, Prosanta Gope,Member, IEEE , and Jianting Ning [2019,VOL.99,NO.99]
- [3] Continuous Human Motion Recognition With a Dynamic Range-Doppler Trajectory Method Based on FMCW Radar, Chuanwei Ding ,Student Member, IEEE, Hong Hong , Member, IEEE, Yu Zou, Student Member, IEEE, Hui Chu , Xiaohua Zhu, Member, IEEE, Francesco Fioranelli, Julien LeKernec, and Changzhi Li, [2019,VOL.57,NO.9,]
- [4] PRNU-Based Camera Attribution from Multiple Sea Carved Images, B Samet Taspinar, Manoranjan Mohanty, and Nasir Memon.[2017,VOL. 20, NO. 5, ]
- [5] An Integrated Cloud-Based Smart Home Management System with Community Hierarchy,Ying-TsungLee, Wei-HsuanHsiao,Chin-MengHuang and Seng-Cho T. Chou. [2016, Vol No: 2162-237X]--

# Drowsiness Detection using CNN

Sheela. S<sup>a,1</sup>, Jothika. D. E<sup>b</sup>, Swarnapriya. N<sup>b</sup>, Vishali. B. R<sup>b</sup>

<sup>a</sup>Assistant Professor, Dept of ECE, Rajalakshmi Institute of Technology, India

<sup>b</sup>Dept of ECE, Rajalakshmi Institute of Technology, India

**Abstract.** Driver drowsiness has become one of the leading causes of car accidents in recent years resulting in serious physical injuries, fatalities and substantial financial losses. According to statistics, a reliable driver drowsiness detection system is needed to warn the driver before a collision occurs. Behavioural, physiological and vehicle based measures are used by researchers to assess driver drowsiness. A thorough examination of these measures will shed light on the current systems, their problems, and the improvements that must be made in order to create a reliable system. By doing other measures will reveal existing systems, their flaws and the changes that must be made in order to produce a credible system.

**Keywords:** Drowsiness, Neural Network, Image processing.

## 1. Introduction

According to available statistics, each year people die on the road is nearly 1.3 million and around 50 million peoples are suffering from non-fatal injuries as a result of traffic accidents. At the wheel if a driver falls asleep, the car loses its control and crashes into another vehicle or stationary objects. The driver's level of drowsiness should be monitored to stop these fatal accidents. The following tools have been widely used to track drowsiness:

1) Vehicle based measures: Deviations from lanes, steering wheel rotation, accelerator pedal pressure, and other factors are continuously tracked, and any change that exceeds a predetermined level signals indicates that the driver is drowsy.  
2) Behavioural measures: A camera tracks the driver's actions, such as eye closing, eye twitch, head posture, and yawning, and if any of these drowsiness signs are observed the driver is alerted.  
3) Physiological measures: Many studies have looked into the relationship between physiological signals (ECG, EMG, EoG and EEG) and driver drowsiness. One of the important safety features is drowsiness detection that can avoid accidents caused by driver's drowsiness.

The aim of this study is to detect and alert the person when eyes are not opened for a particular duration. When drowsiness is detected, this system will notify the driver.

---

<sup>1</sup>Sheela.S, Assistant Professor, Rajalakshmi Institute of Technology, Chennai, India.  
Emailid: ssheela97@gmail.com

## 2. Methodology

Driver exhaustion and drowsiness are significant contributors to various automobile accidents. In the field of accident prevention systems, designing and maintaining technology that can effectively identify or avoid drowsiness at the wheel and warn the driver before a collision is a major challenge. We use OpenCV to take images from a webcam and these images given to a deep learning algorithm that can tell whether someone's eyes are closed or opened. In this case, we are looking for the persons face and eyes.

Step1: Image is taken as input from camera.

We'll use a camera to capture photographs as input. But, in order to gain access to the webcam, we created an endless loop that captures each frame. We employ the cv2 method given by OpenCV. VideoCapture(0) (cap) is used to access the camera and capture the object. With cap.read(), each frame is read, and then image is saved in a variable.

Step 2: Create a ROI by detecting a face in the picture.

To segment the face in the captured image, we first converted it to gray scale because, the OpenCV object detection algorithm only accepts grayscale images as input. To detect the objects, we don't need colour detail. We use the Haar cascade classifier to detect the face. The classifier face= cv2.CascadeClassifier('haarcascade\_frontalface\_default.xml') is set with this section. for (x,y,w,h)in faces, we use cv2.rectangle(frame, (x,y), (x+w, y+h), (100,100,100), 1

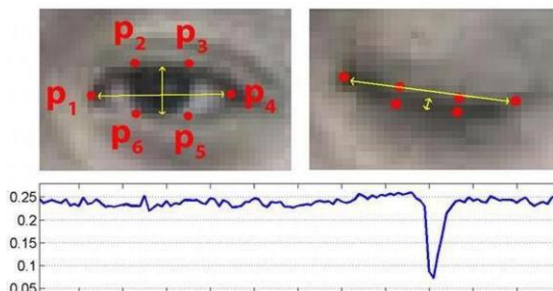
Step 3: Use the ROI to find the eyes and feed them to the classifier.

The technique for detecting eyes is the same as for detecting ears. Cascade classifier is used in left and right eyes.

Then, use left\_eye=eye.detectMultiScale(gray) to detect the eyes. We extracted only the details of eyes from the captured image. This can be done by first removing the eye's boundary box and then using this code to remove the eye image from the picture.

$$l\_eye = frame[y : y+h, x : x+w]$$

This information is given to CNN, which decides whether the eyes are closed or not. The right eye also detected in the above manner.



**Figure1:** Detection of Eyes using OpenCV

Step 4 – The classifier will determine whether or not the eyes are open.

The eye status is predicted using a CNN classifier to feed the image into the model, since the model requires the proper measurements to begin with. We begin by converting the colour picture to grayscale.

```
r_eye=cv2.cvtColor(r_eye,cv2.COLOR_BGR2GRAY).
```

Then, since the model is trained on images with a resolution of 24\*24 pixels, We resize the image to 24\*24pixels.

```
cv2.resize (r_eye, (24,24)).
```

For better convergence, the data is normalized.

```
r_eye = r_eye/255
```

The model is loaded using `model=load_model(,models/cnnCat2.h5")`

Now, each eye is predicted with the proposed model.

```
lpred=model.predict_classes(l_eye)
```

If `lpred[0] = 1`, it means that eyes are open, if `lpred[0] = 0` then, it means that eyes are closed.

Step 5: Score Calculation.

The score is essentially a number that we'll use to figure out how long the individual has been closed-eyed. As a consequence, if both eyes are closed, we will begin to raise the score, but if both eyes are open, we will decrease the score. We're using the `cv2.putText()` function to draw the result on the screen, which displays the status of the driver or a person.

```
cv2.putTxx(frame,"Open",(10,height20), font,1,(255,255,255),1,cv2.LINE_AA )
```

A criterion is established, for example, if the score exceeds 15, it indicates that the person's eyes have been closed for an extended amount of time. Then the alarm turned on.

Step 6: To run the file

You can either open the command prompt or navigate to the directory containing our key file

“drowsiness detection.py” as shown on the picture above by using the command below: Python

```
“drowsiness detection.py”
```

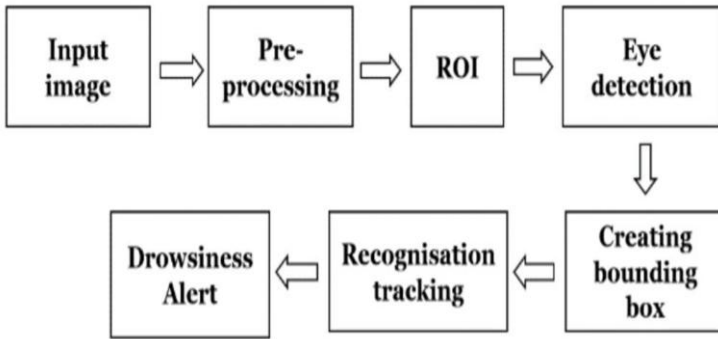


Figure 2: Block Diagram for Drowsiness Detection Using CNN

### 3. Results and Discussions

The first image output shows the normal state of the person without any signs of drowsiness so the score value is 0. As for the second image the score value is beyond 15 so the detection system alerts the person by a sound alarm creating a bounding box.

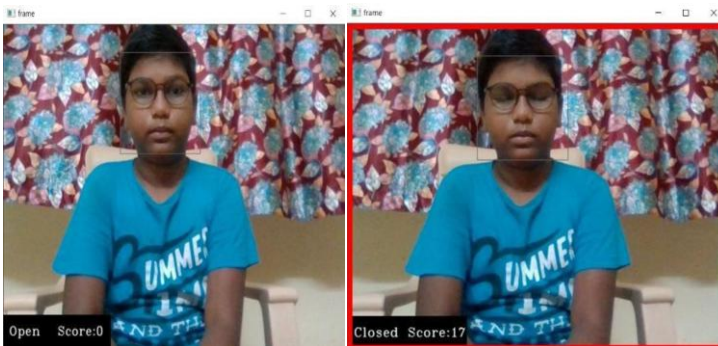


Figure 3: Drowsiness Detection

### 4. Conclusion

The Drowsiness Detection System, which is based on the driver's eye closure, can discern between normal eye twitch and drowsiness, as well as detect drowsiness when driving. The suggested scheme will help deter injuries caused by drowsy driving. Using a Haar cascade classifier, OpenCV was used to detect faces and eyes, and then a CNN model to predict the status. A alert signal is provided when the eyes are closed for an extended amount of time. Continuous eye closures are used to assess the driver's alertness level. For the future work, this detection system can be made into hardware with advanced features.



## References

- [1] Ann Williamson and Tim Chamberlain. Review of on-road driver fatigue monitoring devices. NSW Injury Risk Management Research Centre, University of New South Wales, , July 2013.
- [2] C. Hentschel, T. P. Wiradarma, and H. Sack, Fine tuning CNNs with scarce training data-adapting imagenet to art epoch classification, in Proceedings of the IEEE International Conference on Image Processing (ICIP), Phoenix, AZ, USA, September 2016.
- [3] K. He, X. Zhang, S. Ren, and J. Sun, Deep residual learning for image recognition, in Proceedings of the IEEE Conference on Computer Vision and Pattern Recognition, Las Vegas, NV, USA, June 2016.
- [4] ZuopengZhao,LanZhang,Hualin Yan, Yi Xu, and Zhongxin Zhang, Driver Fatigue Detection Based on Convolutional Neural Networks Using EM -CNN, 2020.
- [5] MiluPrince,NehaSanthosh,NehaSanthosh, Reshma Sudarsan & Ms.AnjusreeV.K,Rajagiri School of Engineering And Technology - Eye Movement Classification Using CNN.
- [6] AnjithGeorge and AurobindaRoutrayDept. of Electrical Engg., IIT Kharagpur Kharagpur, 721302, India – “Real-time Eye Gaze Direction Classification Using Convolutional NeuralNetwork”.
- [7] HaoxiangLi ,ZheLin, XiaohuiShen , Jonathan Brandt , Gang HuStevensInstitute of Technology Hoboken, NJ 07030- A Convolutional Neural Network Cascade for FaceDetection.
- [8] Venkata Rami Reddy Chirra,Srinivasulu Reddy Uyyala& Venkata Krishna Kishore Kolli, Department of Computer Applications, National Institute of Technology, Tiruchirappalli 620015, India – “Deep CNN: A Machine Learning Approach for Driver Drowsiness Detection Based on Eye State
- [9] V.D.Ambeth Kumar et.al., , “Performance Improvement Using an Automation System for Segmentation of Multiple Parametric Features Based on Human Footprint” for the Journal of Electrical Engineering & Technology , vol. 10, no. 4, pp.1815-1821 , 2015. [http://dx.doi.org/10.5370/JEET.2015.10.4.1815]
- [10] Ambeth Kumar.V.D et.al. .A Survey on Face Recognition in Video Surveillance. Lecturer Notes on Computational and Mechanism, Vol. 30, pp: 699-708, 2019
- [11] Ambeth Kumar.V.D .Precautionary measures for accidents due to mobile phone using IOT.Clinical eHealth, Volume 1, Issue 1, March 2018, Pages 30-35.
- [12] Ambeth Kumar.V.D et.al. Enhancement in Footprint Image using Diverse Filtering Technique. Procedia Engineering journal, Volume 8, No.12, 1072-1080, 2012. [doi:10.1016/j.proeng.2012.01.965]
- [13] Nanagasabapathy.K et.al, Validation system using smartphone luminescence. IEEE International Conference on Intelligent Computing, Instrumentation and Control Technologies (ICICT), Pages: 235 – 239, 6-7 July 2017, Kannur, India
- [14] Aravindh.B et.al, A novel graphical authentication system for secure banking systems. IEEE International Conference on Smart Technologies and Management for Computing, Communication, Controls, Energy and Materials, Pages: 177 – 183, 2-4 Aug. 2017, Vel Tech University, Chennai, India
- [15] S.V. Ruphitha et.al, Management of Major Postpartum Haemorrhage by using Zigbee protocol - A Review .2021 6th International Conference on Inventive Computation Technologies (ICICT) (DOI: 10.1109/ICICT50816.2021.9358757 )
- [16] Indhumathi.M et.al .Healthcare Management of Major Cardiovascular Disease-A review.2021 6th International Conference on Inventive Computation Technologies (ICICT), (DOI: 10.1109/ICICT50816.2021.9358519 )

# Brain Tumor Detection Using Gray Level Co-Occurrence Matrix Feature Extraction Technique

SheelaS<sup>a,1</sup>, R.Prema<sup>b</sup>, S.Ramya<sup>b</sup>, B.Thirumahal<sup>b</sup>

<sup>a</sup>Assistant Professor, <sup>c</sup>Department of ECE, Rajalakshmi Institute of Technology, Chennai, India

<sup>b</sup>Department of ECE, Rajalakshmi Institute of Technology, Chennai, India

**Abstract :** From each and every passing year, the world has always witnessed a rise in the number of cases of brain tumor. Brain tumor classification and detection is that the most critical and strenuous task within the field of medical image processing while human aided manual detection leads to imperfect divination and diagnosing. Brain tumors have high heterogeneity in appearance and there is a same feature between tumor and non-tumor tissues and thus the extraction of tumor regions from MRI scan images becomes unyielding. A Gray Level Co-occurrence Matrix( GLCM) is applied on MRI scan images to detect tumor and non-tumor regions in brain. The main aim of medical imaging is to extract meaningful information accurately from the images. The method of detecting brain tumor from an MRI scan images are often classified into four categories: Pre-Processing, Skull Stripping, Segmentation and have Feature Extraction.

**Keywords:** Brain Tumor, GLCM, Segmentation, Feature Extraction, Classification

## 1. Introduction

A brain tumor is an unusual cell in the brain. Your cranium, which encases your brain, is exceptionally reserved. Any development interior such a confined space can cause issues. Brain tumors can be classified as a Malignant tumors (Cancerous) and Benign tumors(Non-Cancerous) [1]. When kind or dangerous tumors develop, they can cause the pressure interior your cranium to extend. This may cause brain harm, and it can be life-threatening. Brain tumors are categorized as essential or auxiliary. An essential brain tumor begins in your brain. Numerous essential brain tumors are kind. An auxiliary brain tumor, too known as a metastatic brain tumor, happens when cancer cells spread from another organ such as lung or breast to brain. A brain tumor called an intracranial tumor, is an anomalous mass of tissue in which cells develop and increase wildly, apparently unchecked by the components that control typical cells. More than150 distinctive brain tumors have been reported, incorporate tumors that begin from the tissues of the brain or the brain's quick environment. Essential tumors are

---

<sup>1</sup> Sheela.S, Assistant Professor, Rajalakshmi Institute of Technology, Chennai, India.  
Email id:ssheela97@gmail.com

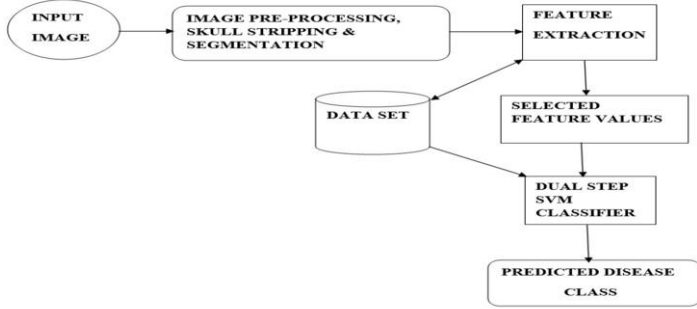
characterised as glial or non-glial (created on or within the structures of the brain, counting nerves, blood vessels and organs) and generous or malignant. Secondary Brain Tumors incorporate tumors that emerge some place within the body (such as breast or lungs) and move to the brain, ordinarily through the circulation system. Metastatic or Auxiliary Brain Tumors are considered cancer and are threatening. Pre-processing is a first step to improve the picture quality and remove the noise. Skull Stripping is the process that removes the skull layer of the brain image. Segmentation is an important task in the field of medical image analysis and for radiological evaluation or computer aided diagnosis system, classification plays major role [2]. The final step is the classification to classify the brain image whether it is a benign or malignant. Praveen et.al [3] proposed a technique using Fuzzy C-Means (FCM) and SVM classifier for brain tumor detection. In this, first the MRI images are enhanced. Then, skull skipping is done using morphological operations. Finally, from the segmented image GLCM features are extracted to classify the suspicious region using SVM classifier. Several research works are carrier out to detect the brain tumor. H. S. Abdulbaqi et.al [4] developed an algorithm using Markov Random Field technique to classify brain tumor from MRI images. In this technique, input MRI images are converted into 2D images and segmentation is done using thresholding technique. Mind Tumor Location Utilizing Self Versatile K-Means Grouping is developed by Navpreet Kaur [5].

## 2. Methodology:

This paper creates a novel calculation to identify the sort of brain tumor called lower review glioma by expanding the fundamental novel bolster vector machine. At first the Brain tumor pictures are recovered from the database and they are pre-processed to remove the commotion display within the foundation. Furthermore, the highlights of the irregular and ordinary brain pictures are extracted. Thirdly the double step SVM is executed. Within the to begin with step of double SVM, the SVM show is prepared to classify the images utilizing the highlights extricated from the anomalous and ordinary brain pictures. Within the moment step, the SVM demonstrate is prepared to classify lower review glioma and other distinctive sort. Lower review glioma is the starting tumor organize and it can be distinguished with higher precision utilizing the over said calculation which can certainly offer assistance the specialists to pre plan the surgery some time recently animosity.

### 2.1 Image processing

An image pre-processing point to move forward the picture data by smothering the undesired twists and enhances some of the picture highlights that will be supportive in further handling. The objective of Pre processing is to get rid of the commotion and to supply Differentiate Upgrade to improve the picture quality.



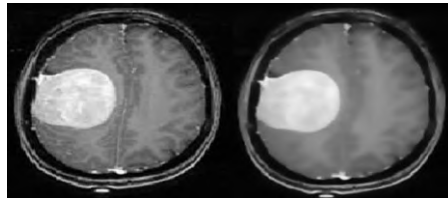
**Figure 1.** Block diagram of proposed model

## 2.2 Grayscale Imaging:

Grayscale may be a run of update gray without clear color. The darkest possible shade is dark, which is that the complete absence of transmitted or reflected light. The lightest possible shade is white, the entire transmission or reflection of daylight in the least unmistakable wavelengths. So due to the above reasons to begin with we change over our MRI picture to be pre-processed in grayscale picture.

## 2.3 Median Filter

This is the first common method which used for noise disposal. It may be a ‘non-linear’ filtering method. Typically want to eliminate ‘Salt and Pepper noise’ from the greyscale image. Middle channel is predicated on the average esteem of pixels. The preferences of median channel are proficient in decreasing Salt and Pepper noise and Dot noise. Moreover, the edges and boundaries are protected. The main disadvantages are complexity and time consumption as compared to cruel filter.



**Figure 2.** a.Input image b.Median filtered image

## 2.4 Skull Stripping

Skull removal could be a vital step in medical image process as a result of the background of the magnetic resonance imaging image not containing any helpful data, and it solely will increase the time interval. To removed the Otsu’s portion from the magnetic resonance imaging pictures in 3 steps. These 3 steps are: a) Otsu Thresholding: For Otsu’s removal, initially we tend to used Otsu’s Thresholding technique that mechanically calculates the brink price and segments the image into background and foreground. during this technique, the brink that’s designated minimizes the intra-class variance, outlined as a weighted total of deviations of the 2

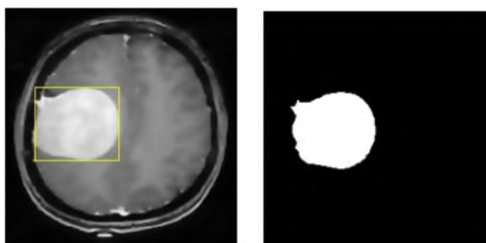
categories. b) Connected part Analysis: At the last stage of our Otsu's removal step, we tend to used connected part analysis to extract solely the brain region and as a consequence the Otsu's half was removed.

### 2.5 Segmentation

Segmentation may be a troublesome step in medical imaging since the pictures are as well complex. In segmenting handle, the picture is part into several partitions steady with their color, concentrated etc. This makes a difference to observe and analyze the little print of the pictures and supply exact comes about. There are several segmentation strategies.

### 2.6 Threshold Image

Threshold division is one of the simplest segmentation strategies. The strategy is based on threshold esteem which can convert the grayscale image is one of the best division strategies. The method is based on limit esteem which can convert the grayscale picture into double organize. In the threshold division, there are a few methods where we utilize neighbourhood strategies which adjust the edge value on each pixel to the nearby picture characteristics for division.



**Figure 3.** Image segmented using Thresholding based algorithm

### 2.7 Feature Extraction

Classification is done using texture based features and statistical based features. Among several features, energy, correlation, mean, standard deviation, centroid is extracted from the segmented image.

#### *Gray-level Co-occurrence Matrix*

Co-Occurrence matrix is generated and then, texture features are measured from the Co-Occurrence matrix. GLCM is used in several applications like biomedical, remote sensing techniques.etc. Basic of GLCM surface considers the connection between two neighbouring pixels in one balanced, as the moment arrange surface. The gray esteem connections in a target are changed into the co-occurrence network space by a given bit veil such as 33, 55, 77 and so forward. Within the change from the picture space into the co -occurrence lattice space, the neighbouring pixels in one or a few of the eight characterized bearings can be utilized; regularly, four course such as  $0^\circ$ ,  $45^\circ$ ,  $90^\circ$ , and

135° is at first respected, and its switch heading (negative heading) can be moreover numbered under consideration.

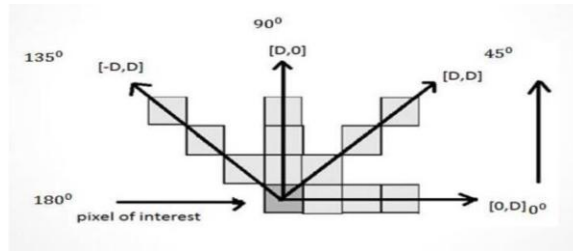


Figure 4. GLCM Directions

## 2.8 Classification

Image classification incorporates classification of pictures into sub categories. It is considered a really critical and troublesome assignment. The classifier procedure is required to classify the data set into categories.

### Support Vector Machine(SVM)

One of the supervised machine learning model is Support Vector Machine (SVM) which uses algorithms for classification. It offers tall precision and performs speedier forecast when compared to Naive Bayes calculation. It can be utilized in both classification and relapse issues. It out-performs with tall dimensional space and with a clear edge of separation.

Here we are utilizing Double Step SVM classification in arrange to classify ordinary as well as irregular and Lower- grade Vs Higher-grade. In arrange to classify climate, the tumor is typical or anomalous we go for SVM1 classifier which employments GLCM Highlights. And, in arrange to classify Lower-grade or Higher-grade glioma we go for SVM2 classifier which employments Locale Property Features.

## 3. Conclusion

This extend, different procedures that are being utilized to detect the brain tumor from MRI scan images of brain are evaluated. The proposed strategy has the capability to create compelling comes about indeed in case of tall density of the tumor. The proposed venture will identify the presence of brain tumor with 99% accuracy.

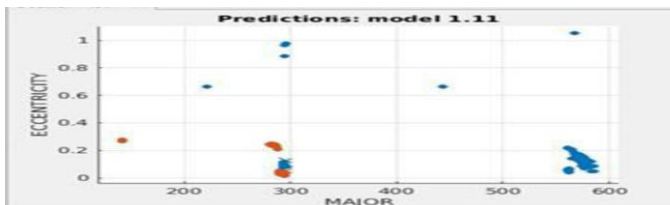


Figure 5. Output of SVM Classifier

## References

- [1] Mohan G, Subashini MM. MRI based medical image analysis: Survey on brain tumor grade classification. *Biomed Signal Process Control* 2018;39:139–61.
- [2] Dhawan, A. P., A Review on Biomedical Image Processing and Future Trends, *Computer Methods and Programs in Biomedicine*, Vol. 31, No.3-4, 1990, pp.141-183.
- [3] Parveen, & Singh, Amritpal. (2015). Detection of brain tumor in MRI images, using combination of fuzzy c -means and SVM. 98102. 10.1109/SPIN.2015.7095308.
- [4] H. S. Abdulbaqi, MohdZubir Mat, A. F. Omar, I. S. B. Mustafa and L. K. Abood, Detecting brain tumor in Magnetic Resonance Images using Hidden Markov Random Fields and Threshold techniques, 2014 IEEE Student Conference on Research and Development, Batu Ferringhi, 2014, pp. 1-5.
- [5] Navpreet Kaur and Manvinder Sharma. Brain tumor detection using self-adaptive Kmeans clustering. 2017 International Conference on Energy, Communication, Data Analytics and Soft Computing (ICECDS) (2017): 1861- 1865.
- [6] Ambeth Kumar.V.D et.al., .Performance Improvement Using an Automation System for Segmentation of Multiple Parametric Features Based on Human Footprint.for the *Journal of Electrical Engineering & Technology* . vol. 10, no. 4, pp.1815-1821 , 2015. [<http://dx.doi.org/10.5370/JEET.2015.10.4.1815>]
- [7] Ambeth Kumar.V.D et.al. , A Survey on Face Recognition in Video Surveillance. *Lecturer Notes on Computational and Mechanism*, Vol. 30, pp: 699-708, 2019
- [8] Ambeth Kumar.V.D, Precautionary measures for accidents due to mobile phone using IOT.*Clinical eHealth*, Volume 1, Issue 1, March 2018, Pages 30-35.
- [9] Ambeth Kumar.V.D et.al, Enhancement in Footprint Image using Diverse Filtering Technique. *Procedia Engineering journal*, Volume 8, No.12, 1072-1080, 2012 . [doi:10.1016/j.proeng.2012.01.965]
- [10] Nanagasabapathy.K et.al, Validation system using smartphone luminescence. *IEEE International Conference on Intelligent Computing, Instrumentation and Control Technologies (ICICT)*, Pages: 235 – 239, 6-7 July 2017, Kannur, India
- [11] Aravindh.B et.al, A novel graphical authentication system for secure banking systems.*IEEE International Conference on Smart Technologies and Management for Computing, Communication, Controls, Energy and Materials*, Pages: 177 – 183, 2-4 Aug. 2017, Vel Tech University, Chennai, India
- [12] Ruphitha.S.V et.al, .Management of Major Postpartum Haemorrhage by using Zigbee protocol - A Review. 2021 6th International Conference on Inventive Computation Technologies (ICICT) (DOI: 10.1109/ICICT50816.2021.9358757 )
- [13] Indhumathi.M et.al . Healthcare Management of Major Cardiovascular Disease-A review. 2021 6th International Conference on Inventive Computation Technologies (ICICT), (DOI: 10.1109/ICICT50816.2021.9358519 )

# Role of Digital Marketing Data Analytics in Film Industry: Telugu Cinema into Pan India Magnum Opus

Janardhan Juvvigunta<sup>1, a</sup>, Gondi Surender Dhanunjay<sup>a</sup>, Adesh Kumar<sup>b</sup>, Manoj Kumar Padhy<sup>b</sup>, Abhishek Kumar<sup>b</sup> and Pranjal Singh<sup>b</sup>

<sup>a</sup> School of Computer Science and IT, JAIN (Deemed to be University)

<sup>b</sup> Faculty of Law, Banaras Hindu University

**Abstract.** The Indian film industry is at average growth rate of 11.5% year-on-year basis. After the Hindi film industry, regional cinema like the Telugu industry (popularly known as Tollywood) is the next big industry in the country in terms of both quantitative and qualitative values (Neway, 2020). Despite having limitations of language, nativity audience, market size, the Telugu film industry has emerged as synonyms for magnum opus with the help of digital marketing approaches in the 21<sup>st</sup> Century. S.S. Rajamouli's visually spectacular, Baahubali franchise garner incredible national appeal and emerged as the biggest box-office opener in the country. With INR 600 crore gross worldwide, Bahubali: The Beginning not only became a benchmark for technical and aesthetic values but also became a well-studied case for its marketing approaches which changed the entire style of film promotions in the digital era. Similar kind of strategy has been followed by Syraa and Saaho in the Telugu film industry. At this juncture, the researcher aims to study the film audience pulling marketing strategies that applied particularly in all three stages (pre, post & production stages) of film production in Telugu Cinema. Purposively the researcher selected Syraa and Saaho as samples to study the objectives of this research work and adopted the content analysis to interpret the secondary data to present the research findings.

**Keywords.** Regional Cinema, Telugu Cinema, Digital Marketing Strategies, Digital Marketing Analysis, Magnum opus.

## 1. Introduction

The Indian film industry is an expected growth rate of 11.5% year-on-year basis, reaching a total gross of INR 23,800 crore by 2020 (ET Bureau, 2017). After the Hindi film industry, regional cinema like the Telugu industry (popularly known as Tollywood) is the fore frontier as the second biggest industry in the country in terms of both quantitative and qualitative values (Neway, 2020). Despite having limitations of language, nativity audience, market size, the Telugu film industry has emerged as synonyms for magnum opus by adopting digital marketing approaches in the 21<sup>st</sup> Century. Earlier, regional cinema has treated differently from Hindi cinema which is popular as the Indian national cinema in one section of film audience and marketers due to the out-of-reach in other parts of India except in their region. In another side,

---

<sup>1</sup> Abhishek Kumar, Scholar, PGDMLMC, Faculty of Law, Banaras Hindu University & School of Computer Science and IT, JAIN, Deemed to be University, Bangalore  
E-mail: abhishek.maacindia@gmail.com



Hindi cinema is accessible to all the northern region of India similarly Telugu, Tamil, Kannada and Malayalam are limited to Southern part of India. After the 1990s, Globalization policies introduced in India enabled collaborations among all the stakeholders in the same industry through the investments. It resulted in the expansion of every sector in the business. The Indian film industry is not exceptional. It witnessed holistic growth in terms of expansion of Production, distribution exhibition and strengthening the theatre system even in small towns. During the year 2005-2006 saw the initial results of digital distribution in India. During the year 2008-2009 has taken up momentum noticeably. The year 2008 witnessed some prominent films taking the digital distribution route in a big way, Singh is King (2008) digital theatres or Ghajini (2008) which released the maximum number of prints in India (1200 digital & analogue versions) and made inroads to even some semi-urban places where films never released on the same day as the rest of the world. Corporations brought the changes in business perceptions; film talents have started to fly from one industry to another from Hindi cinema to regional cinema also from Indian Cinema to World cinema vice versa. Initially, it has considered as accommodating the talent for getting better and fresh results from technicians and artists as script demands. Later, filmmakers have realized that accommodation of star casting and technicians having the market value equally with the aesthetic value. It was greatly amplified by the Telugu film director S.S. Rajamouli. When he announced visual spectacular and highly narrated, periodical, and fictional drama with Tollywood actor Prabhas in February 2011. The script started accommodating the pan-India artists that resulted in the rise of on movie budget. Arka Media Works, the makers of Baahubali adopted innovative and cost-effective marketing strategies to create a buzz around the movie because of accessibility of internet facility in India. The country owns the world's second-largest internet population at over 483 million users in 2018 (Sandhya Keelery, 2020). In which, 390 million users accessed the internet via their mobile phones. These magical figures would reach over 500 million by 2023 estimated by the market experts (Statista, 2020). Size is not the only metric; demography is also a metric. According to KPMG in India Analysis April, 2017 there were 110 Million internet users in India out of which 68 million were English internet users and 42 million were Indian language internet users, in 2016 out of total 409 million internet users, 175 million were English internet users and 234 million were Indian language Internet users. It is also estimated that by 2021 there will be 735 million internet users of which 199 million will be English internet users and 536 million will be Indian language Internet users.

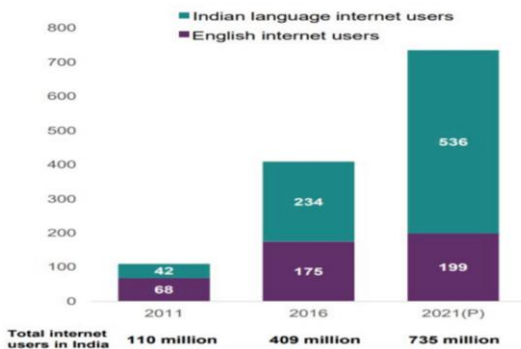
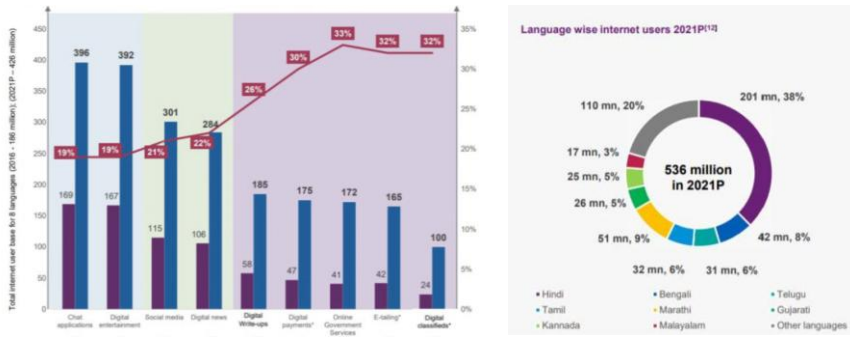


Figure 1. Internet user base in India (in million) 2011, 2016 & 2021.

The KPMG Survey report also says that 99% of Indian Language users accessing internet are accessing on their mobile devices.68% of Internet users consider local language digital content to be more reliable than English. The KPMG Survey report also Predicts that Digital Entertainment will have high adoption level from 2016 to 2021, projecting that user base of 167 million will increase more than 230% and is estimated to be used by 396 million.



**Figure 2.** Category Wise Indian Language Internet Users and Telugu language users are in top three

It also estimates that Telugu language content internet users will be in the third top list in Indian Languages. During the raising period of Telecommunication in India, The Baahubali-franchise production house has made its online presence in 2013, that he announced the working title Baahubali. Releasing the first look of the lead actors in the movies and updates about the schedules, teasers, character promos, and release dates, etc. in digital platforms such as official Twitter, YouTube, and other social media accounts. With INR 600 crore gross earnings worldwide, Bahubali: The Beginning not only became a benchmark for technical and aesthetic potential but also became a well-studied case for its marketing strategies. As many industry experts and filmmakers point out, nearly 40% of Baahubali’s commercial success can be endorsed to its aggressive and innovative marketing approaches (A.J.Swapna et al., 2016). Baahubali appeared on the social media having: 26.42 lakh likes (people) on Facebook Page, 1.48 lakh followers on Twitter Profile, 1.38 lakh subscribers on YouTube channel. Baahubali: The beginning also stands in 4th place among the many top 10 most discussed topics on Facebook in 2015 after Prime Minister Narendra Modi, E-commerce Boom and late President and scientist APJ Abdul Kalam (Sakshi Kotecha, et al., 2017). Baahubali style of marketing approaches such as pre-production, production, post-production and after release have become an ideal practice for making such a visual treated, high budget movie and make it as a pan-India magnum opus. These approaches changed the entire style of film promotions in the digital era. That proved with the immediate releases of Syraa (2019) and Saaho (2019) in the Telugu film industry.

**2. Methodology**

At this juncture, the researcher aims to study the film audience pulling marketing strategies that applied particularly in all three stages (pre, post & production stages) of

film production in Telugu Cinema. Purposively the researcher selected Syraa (2019), and Saaho (2019), as samples to study the objectives of this research work and adopted the content analysis methodology to interpret the secondary data to present the research findings.

### **3. Results & Discussion**

Film promotion is a powerful marketing tool, not only during the premiere of a new movie but throughout its lifecycle. In 21st-century, the film promotion has completely changed with the reach of digital media that enabled to create new models for marketing a film in all the stages of its making. The film industry is most uncertain because of its complexity in nature. The reasons for that is its creativity, its diversity and its continual explosions of technological delivery options (Shashi Pande, 2017). During the pre-digitalization of Indian cinema, film promotions took place mainly at the production level and distribution level. It has predominantly transformed into 24X7 and 365 days due to its high budget and pan-India star casting. Every small occasion is also having promotional value and occupies space in Print media, Time in TV& Radio, data consumption in Digital Media. Therefore, with the inspiration of the makers of Baahubali-franchise, Regional filmmakers have adopted digital marketing approaches to bring their products into end-users via Social media platforms.

Sye Raa Narasimha Reddy (2019) Digital Marketing Approaches: Telugu Cinema Megastar, Chiranjeevi, the lead role portrayed as Sye Raa Narasimhareddy (2019) has openly said that Baahubali showed the way for making high budget movies with pan-India casting. Sye Raa is advertised as the next big project in Indian cinema after Saaho (2019). Starring an ensemble star cast such as Amitab Bachchan, Vijay Sethupathi, Tamannaah, Nayanthara, Sudeep, Jagapathi Babu and Ravi Kishan, the film tells the story of Uyyalawada Narasimha Reddy, the rebellion leader from Rayalaseema who fought valiantly against the British East India Company. Through announcing the Pan-India casting, the production house, Konidela Production Company created a movie buzz across the country. On 21st August 2017, Sye Raa makers have released first look motion poster in YouTube it accounted the 5, 209, 939 views within record time. Even after that Konidela Production Company has released first glims on 20th August 2018, that accounted 2,22,03, 901 views. Sye Raa team has planned to add voice overs with various stars in their respective language such as Pawan Kalyan for Telugu, Rajinikanth for Tamil and Mohanlal for Malayalam. Pawan Kalyan voice over for Sye Raa Teaser- Promo released on 18, August 2019 got the 36, 42, 556 views. Konidala Pro Company official Twitter account has been hitting by digital-savvy for searching the SYE RAA Lead roles first looks on their birthday occasions. Amitab Bacchan's first look as Gosayi Venkanna received 5.9 thousand likes on 10th October 2018, Nayanatara motion poster has got the 40,66, 601 views on 17th November 2018 for her first look as queen Siddhamma. On 1st September 2018, Kannada superstar Sudeep look as Avuku Raju first look has accounted over eight thousand likes in Konidala Pro Company official Twitter account. These number highlighted the positive side of digital media even two years before the release of its release in theatre on 2nd October 2019. Sye Raa Narasimha Reddy digital rights have sold for INR 40 crore before the release itself. It has reportedly done the table business of INR 110 crores as a pre-release business only because of its digital marketing

approaches (ToI, 2019). When the film is screening in theatres co-stars are tweeting about it and greeting the film crew influencing its performances at the box office. The gesture turns into a cordial and positive promotion and it has influenced some section of audiences during the first two weeks of its releases.

**Table:1** SYE RAA NARASIMHAREDDY Movie Buzz in Digital Media

Digital Marketing Stages	SYE RAA Teaser/Promo/First Look	Medium	Digital Views
Pre-Production	First Look Motion Poster released in YouTube on 21 <sup>st</sup> August 2017	YouTube	5,209,939 views
Production	SYE RAA first glimpse released 20 <sup>th</sup> August, 2018	YouTube	2,22,03, 901 views
	Amitab Bacchan's first look as 'Gosayi Venkanna' released on 10th October 2018	Twitter	5.9 thousand likes
	Nayanatara Motion Poster first look released as queen 'Siddhamma' on 17th November 2018	YouTube	40,66, 601 views
Post-Production	Pawan Kalyan voice over for Sye Raa Teaser-Promo released on 18, August 2019	YouTube	36, 42, 556 views
After release	Mahesh Babu greetings to SYE RAA team	Twitter	Influenced his followers

Saaho (2019) In Digital Media: The Baahubali-franchise fame Prabhas acted SAAHO (2019) turned as India's largest action-thriller of the year. It has set the buzz across the social media world with a record of more than five million tweets before its theatrical release. SAAHO (2019) has several factors that became social media trending, a twenty-seven-year-old Sujeeth with two films directed experience launched this project with Prabhas immediately after Baahubli world success. The Soundtrack has done with a pool of talents Shankar-Ehsaan-Loy, Tanishk Bagchi, Guru Randhawa and Badshah and background score has given by South Indian Music director Gibran. All these crazy combinations have become the reason for social media buzz. The makers of Saaho, UV Creations has completed 40 days long schedule for shooting action sequences with INR 90 crore budget. Mission: Impossible fame Stunt choreographer Kenny Bates supervised the action sequences in the movie. Prabhas tweeted about next schedule in Abudabi before he joined the crew. The post created more buzz in digital media also in all the film industries (Karthik Kumar, 2018). Strategic release of SAAHO teaser trailer on 13th, June 2019 received over twenty-five million digital views within the six hours and crossed thirty million views in just another six hours. #ShadesOfSaaho, Chapter-I teaser crossed 10 million+ views in just 24 hours. SAAHO trailer released on 13th August 2019, has set a new benchmark with 70 million+ views in various social media. SAAHO digital marketing has also released the first look of leading cast of the film. After the first week of its release SAAHO makers, UV Creations released a separate poster with box office collections that psychologically influenced the audiences to rush to watch it in theatres.

#### 4. Conclusion

21st Century is the era of digital and marketing has become vital, so all the film industries in the country have also adapted to digital marketing approaches to promote films in a unique way where their product can reach millions of potential targeted people. Telecommunication revolution results have become an added factor to the film industry to connect with people in 24X7 and 365 days. The regional film industry, the Telugu film industry has also adopted and extensively applied the digital marketing approaches in all stages of its film projects. During the pre-production with announcing the pan-India castings, in the Production stage, updating the shooting schedules and releasing the first look of its casting and Post-production stage, targeting the digital media savvy by conducting the online competitions, involves the audience as part of promotions. Even after the film release in theatre, they are hitting the digital media with box office collections. These box-office figures are predominantly showing the psychological impact on the audience who has decided to watch the films in their idle time. These extensive box-office figures influence the audience to rush into theatres after a couple of weeks of its release. SAAHO (2019) and SYE RAA NARASIMHA REDDY (2019) stood as the best model for regional cinema became Pan-India Magnum Opus with digital marketing approaches in the same year from the same regional industry.

#### Reference

- [1] A.J. Swapna, Nagendra V Chowdary, (2016), Baahubali-Digital Marketing Strategies and innovative campaigns case, Reference no. 516-0108-1
- [2] Sakshi Kotecha, Namrata A Patil, Giri Y. L, Sandip Rakshit, (2017), Baahubali –A Milestone of Indian Cinema: Digital Marketing Case Study, Fifteenth AIMS International Conference on Management ISBN: 978-1-943295-08-1
- [3] Vishnu Thej Putta, (2020), Digital evolution in Telugu cinema promotions has become part and parcel of industry, ANI, Updated on 20 July, 2020
- [4] Shashi Pande, (NA), Indian Movie Marketing, <https://www.indiastudychannel.com/projects/4700-Indian-Movie-Marketing.aspx>
- [5] Dinesh Madagaonkar (2017), digital way to marketing Indian cinema – a new way of branding indian cinema, *paripex - indian journal of research*, volume: 6 | issue: 2 | February - 2017 ISSN - 2250-1991 | if : 5.215 | ic value : 79.96
- [6] Nivedita Ganguly, (2017), Baahubali Proves Power of Digital Marketing, *The Hindu*, Visakhapatnam, May 02, 2017 07:33 Ist
- [7] ToI (2019), Buzz: Digital rights of Chiranjeevi's Sye Raa Narasimha Reddy sold for this whopping sum, *times of india.COM*, Created: Sep 10, 2019, 16:54 IST,
- [8] Karthik Kumar, (2018), Makers of Prabhas starrer Saaho to spend Rs 90 crore on Dubai schedule, *Hindustan Times*, Chennai, regional movies, Updated: May 03, 2018, 13:56 IST
- [9] Sakshi Kotecha, Namrata A Patil, Giri Y. L, Sandip Rakshit, (NA), Baahubali –A Milestone of Indian Cinema: Digital Marketing Case Study, Fifteenth AIMS International Conference on Management, ISBN: 978-1-943295-08-1
- [10] Gautham Pattikonda, (2019), Sye Raa teaser: Pawan Kalyan for Telugu, Rajinikanth for Tamil and Mohanlal for Malayalam voiceovers, *Bollywoodlife.com*, Published: August 20, 2019 11:00 A Year off script time for resilience - KPMG in India's Media and Entertainment Report 2020.
- [11] Nanagasabapathy.K, G. Harish; O. I. Allen Sebastian; N. Sowrabh Chandra; V. D. Ambeth Kumar. Validation system using smartphone luminescence", *IEEE International Conference on Intelligent Computing, Instrumentation and Control Technologies (ICICT)*, Pages: 235 – 239, 6-7 July 2017, Kannur, India
- [12] Ambeth Kumar.V.D et.al .Cloud enabled media streaming using Amazon Web Services.*IEEE International Conference on Smart Technologies and Management for Computing*,

- Communication, Controls, Energy and Materials, Pages: 195 – 198, 2-4 Aug. 2017, India (DOI: 10.1109/icstm.2017.8089150)
- [13] Aravindh.B,Ambeth Kumar.V.D, G. Harish; V. Siddartht.A novel graphical authentication system for secure banking systems. IEEE International Conference on Smart Technologies and Management for Computing, Communication, Controls, Energy and Materials (ICSTM), Pages: 177 – 183, 2-4 Aug. 2017, Vel Tech University, Chennai, India
- [14] Ambeth Kumar.V.D et.al, (2016).An Efficient Security System for Data base Management from Illegal Access.IEEE International Conference on Wireless Communications, Signal Processing and Networking (WiSPNET), SSN Engineering College, Chennai, India, 23-25 March, 2016

# Tomato Leaf Disease Detection Using Hybrid CNN-RNN Model

Hepzibah Elizabeth David<sup>a,1</sup>, K. Ramalakshmi<sup>b</sup>, R. Venkatesan<sup>c</sup>, G. Hemalatha<sup>d</sup>

<sup>a,1,c</sup>*Department of Computer Science Engineering, Karunya Institute of Technology and Sciences, Coimbatore, India*

<sup>b</sup>*Department of Computer Science Engineering, Alliance College of Engineering and Design, Alliance University, Bangalore, India*

<sup>d</sup>*IT Department, University of Technology and Applied Sciences, Oman*

**Abstract.** Tomato crops are infected with various diseases that impair tomato production. The recognition of the tomato leaf disease at an early stage protects the tomato crops from getting affected. In the present generation, the emerging deep learning techniques Convolutional Neural Network (CNNs), Recurrent Neural Network (RNNs), Long-Short Term Memory (LSTMs) has manifested significant progress in image classification, image identification, and Sequence Predictions. Thus by using these computer vision-based deep learning techniques, we developed a new method for automatic leaf disease detection. This proposed model is a robust technique for tomato leaf disease identification that gives accurate and better results than other traditional methods. Early tomato leaf disease detection is made possible by using the hybrid CNN-RNN architecture which utilizes less computational effort. In this paper, the required methods for implementing the disease recognition model with results are briefly explained. This paper also mentions the scope of developing more reliable and effective means of classifying and detecting all plant species.

**Keywords.** Tomato Disease Classification, Hybrid CNN-RNN, CNN, RNN, LSTM

## 1. Introduction

Tomatoes are the most economically essential vegetable crop cultivated worldwide, and the cultivation methods has been improved through the years. Tomato being a commercial and nutritious food crop plays a significant role in agriculture economy.[1] The plant diseases cause economic, agricultural and ecological losses. Plant disease is a major problem which causes serious issues that impairs food security.[15] The tomato crops are infected by diseases due to various factors like climatic conditions, insects, viruses, bacteria. The tomato leaf diseases affect the growth of the plants and the production of tomatoes which results in agricultural and economic loss. Nearly, in India 10-20% of loss occurs in annual tomato production. Thus, early disease detection prevents the tomato leaf diseases.[5]

---

<sup>1</sup>Hepzibah Elizabeth David, Department of Computer Science Engineering, Karunya Institute of Technology and Sciences, Coimbatore, India; E-mail: hepzibahelizabeth@karunya.edu.in<sup>1</sup>

Image classification has a major role in the identification and detection of the leaf diseases to determine whether the leaf is infected or healthy.[12]

Convolutional Neural Network (CNN) extracts the required image features from an input [6]. Hence it is one of the preferable classification methods in plant leaf disease detection. Major significances of CNN include natural language processing, medical image analysis, image classification. [3]Recurrent Neural Networks (RNN) learns to recognize image features across time, they extract necessary features from the inputs for further classification. They were designed to deal with problems with sequence prediction.[4] Due to the presence of feedback loops in the recurrent layer, RNN remembers its previous inputs. The LSTM layer in RNN, explicitly known for its memory that helps in maintaining the information for long periods.[7] It has been noticed that LSTMs aid feature extraction capability of CNN used in a layered order as they have the ability to remember a selection of long sequences for long duration of time and CNNs can extract important features out of it.[11]

## **2. Related Works**

Plant disease is a major problem in agriculture, that minimizes the quantity of food production and reduces the quality of agricultural products.[13] The heedful disease diagnosis and appropriate handling protects the plants from massive loses. Hence plant disease detection techniques protect the crops from being infected rapidly and improves agricultural growth, the performance of the detection techniques are crucial.[14] Hence the advanced computer vision-based techniques came to compensate the lack of human expertise [4]. In 2011, Neural Network technique has been implemented. This used otsu's method, then the extracted features [5].

In 2012, the Artificial Neural Network (ANN) classifier was used, the images were filtered using the Gabor filter. Then the extracted feature values are trained with the classifier that provides 91% accuracy. [8]. Thus, in the field of agriculture for plant disease recognition and classification the deep convolutional neural networks are implemented [2]. The deep learning Convolutional Neural Network architecture trained with machine learning based model for predicting the tomato plant disease is proposed [7].

The advancements in CNN eventually lead to the development of deep CNN architectures with various pre-trained models like AlexNet, GoogleNet, DenseNet, ImageNET, VGGNet and ResNet have been used for plant leaf disease. In 2018, the deep Convolutional Neural Network based architecture with VGG for disease diagnosis with 99.58% of accuracy which is highly potential when trained and provides best performance compared to other models [9]. In 2019, four deep CNN with two models for object detection, the mask R-CNN and faster R-CNN has been implemented for detection of tomato diseases. [10]. A pre-trained CNN with LSTM based model has been implemented for the detection of pests and apple disease which outperforms the deep CNN based architectures [6]. In 2020, a robust model with RNN based architecture for rapid detection of infected regions in the plants has been introduced [4].



### 3. Proposed System for Tomato Leaf Disease Detection

The previously implemented traditional leaf disease detection models classified the diseases with better performance. These implementations indicated need for early detection. However, those existing models failed to detect the disease in earlier stage.

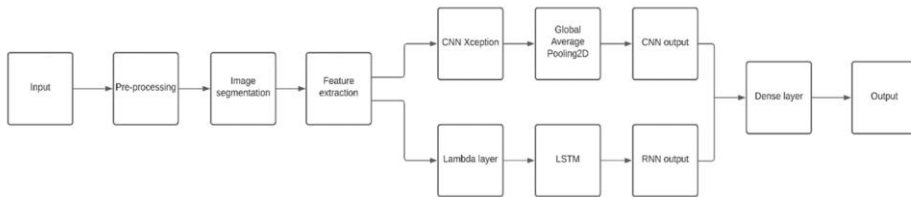


Figure 1. Hybrid CNN-RNN model

Thus, the hybrid CNN-RNN model (Figure 1) has been introduced for the early tomato leaf disease detection. The input image from dataset goes through image pre-processing techniques. Then the image segmentation using label-binarizer is performed. For feature extraction the image pixels (width, height) of each image is taken. The feature values is given to both pre-trained CNN Xception model and RNN model. The outputs from the CNN and the RNN classifiers is multiplied using element-wise multiplication. Then the output enters into the dense layer. And finally, the required output from the data is predicted using the proposed CNN-RNN model.

#### 3.1. Implementation Details

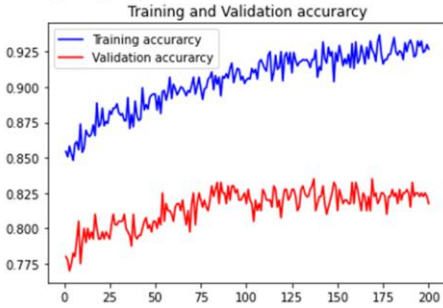
The Plant Village dataset [16] is used for the evaluation of automatic identification and classification of the plant leaf diseases. In this study, 2000 images are taken for training and testing purpose. The folders of tomato leaf disease includes 10 classes of (9 diseases and one healthy class) images are resized to  $256 * 256$  pixels as required for the proposed model. The input image from the dataset is pre-processed using the image data generator which flips, rotates and shears the input image, the values are fixed, such that rotation\_range=25, width\_shift\_range=0.1, height\_shift\_range=0.1, shear\_range=0.2. Then the pre-processed image obtained is used further implementation. The proposed model contains both the CNN and RNN deep learning techniques. Both the CNN and the RNN model runs in parallel state. The pre-trained Xception CNN model, which is also an extension of the inception model. It is an efficient architecture that involves in depth wise separable convolutions known for its improved computation time and depends on shortcuts between convolution blocks.. The CNN bottleneck is also a neural network layer present in the inception network, that helps to reduce number of feature maps (channels) in the model, that tends to increase in each layer. It is defined by using the Global Average Pooling 2D layer from the pre-trained model multiplied with CNN's output. After creating the CNN model, the output shape is computed. Parallely the lambda layers that are useful in saving and inspecting the model in RNN is defined. In Recurrent Neural Network, the rgb\_to\_grayscale inputs, rgb\_to\_grayscale output shape and the input tensor (width, height, channel\_axis) values are acquired. The input shapes are reshaped, with each of the image pixels of  $256 * 256$ . Two parameters is used for reshaping, that are, number of timesteps and the input dimensions for each timestep. The timesteps value can be of

256\*256= 16\*4096= 32\*2048. Then the LSTM layer is included in the model. The Xception CNN’s output shape is taken as the input. Both the CNN’s output and the RNN’s output is multiplied with element wise multiplication. The LSTM initiates predictions from the timesteps obtained. Thus, the predictions is made at x variable for all the classes. The dense layer used, reduces the classes to 10 labels as required and the ‘softmax’ is used as activation function.

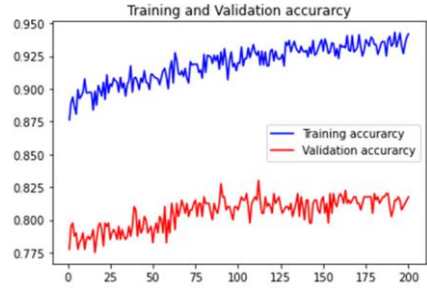
**4. Results**

This section shows the experimental results of the proposed work. This proposed work used 20% of the leaf image dataset for testing. So, the model was trained using 80% of the dataset and validated during each epoch. This model was evaluated based on two timesteps 16 and 32, for each timestep four varying epochs were run to fine tune the model. The complete records of the tests carried in the tuning parameters is mentioned in Table.2.

First paragraph.



**Figure 2.** Training vs validation accuracy for 16 timesteps



**Figure 3.** Training vs validation accuracy for 32 timesteps

**Table 2.** Experimental Results of the model tested with various parameters for hyper-parameter model tuning.

		Epochs	Accuracy (%)	Validation Accuracy (%)	Top K Categorical Accuracy (%)	AUC score (%)
Time Steps	16	50	76.75	71.95	98.25	97.19
		100	78.25	74.41	97.75	96.98
		150	80.75	75.76	98.00	96.96
		200	81.75	81.44	97.50	97.17
	32	50	76.25	71.26	97.50	96.96
		100	79.00	73.79	98.00	97.35
		150	80.50	76.63	98.00	97.35
		200	81.75	80.56	98.25	96.89

From Table. 2, we can observe the model performance and can evaluate the classification capability of the model. The model obtained 98.25% classification accuracy as the highest among the ten classes it was trained and obtained the best overall accuracy of 81.75 for classification. During training, the model started show to signs of overfitting when it was trained for 300 epochs. The other possibility to increase the performance of the model would be increasing number of timesteps, which can be observed from Figure. 2 and Figure. 3. The model can be again tested with

possible different timesteps and input dimensions of the model, and we can further conclude may be increase in timesteps would increase the classification accuracy.

## 5. Conclusion

In agriculture, leaf disease detection is crucial and accuracy with good precision for real-time disease detection is required. Hence, it is essential that the model should identify tomato leaf disease at an early stage, which requires minimum time for detection and less computation effort is also needed when compared with other existing traditional methodologies. This paper proposed a hybrid deep learning CNN-RNN classifier for detection of tomato leaf disease and the implementation and performance analysis of the model was also discussed. Due to its high prediction rate, with time-series data, earlier detection is made possible. The proposed model obtained 98.25% as the best categorical accuracy and accuracy of 81.75% for disease classification. In future, this work can be further hold forth by improving the performance and the robustness of the model for real-time application.

## References

- [1] Batool, Ayesha, et al. Classification and Identification of Tomato Leaf Disease Using Deep Neural Network.2020 International Conference on Engineering and Emerging Technologies (ICEET). IEEE, 2020.
- [2] Sladojevic, Srdjan, et al. Deep neural networks based recognition of plant diseases by leaf image classification. Computational intelligence and neuroscience 2016 (2016).
- [3] Sabrol, H., and K. Satish. Tomato plant disease classification in digital images using classification tree. 2016 International Conference on Communication and Signal Processing (ICCSP). IEEE, 2016.
- [4] Lee, Sue Han, et al. Attention-based recurrent neural network for plant disease classification.Frontiers in Plant Science 11 (2020).
- [5] Al-Hiary, Heba, et al. Fast and accurate detection and classification of plant diseases.International Journal of Computer Applications 17.1 (2011): 31-38.
- [6] Turkoglu, Muammer, Davut Hanbay, and Abdulkadir Sengur. Multi-model LSTM-based convolutional neural networks for detection of apple diseases and pests. Journal of Ambient Intelligence and Humanized Computing (2019): 1-11.
- [7] Adhikari, Santosh, et al. Tomato plant diseases detection system using image processing.1st KEC Conference on Engineering and Technology, Lalitpur. Vol. 1. 2018.
- [8] Kulkarni, Anand H., and Ashwin Patil. Applying image processing technique to detect plant diseases. International Journal of Modern Engineering Research 2.5 (2012): 3661-3664.
- [9] Ferentinos, Konstantinos P.Deep learning models for plant disease detection and diagnosis. Computers and Electronics in Agriculture 145 (2018): 311-318.
- [10] Wang, Qimei, et al. Identification of tomato disease types and detection of infected areas based on deep convolutional neural networks and object detection techniques.Computational intelligence and neuroscience 2019 (2019).
- [11] Nerkar, Bhavana, and Sanjay Talbar. Fusing Convolutional Neural Networks to Improve the Accuracy of Plant Leaf Disease Classification. Current Journal of Applied Science and Technology (2020): 9-19.
- [12] Alimboyong, Catherine R., Alexander A. Hernandez, and Ruji P. Medina. Classification of plant seedling images using deep learning.TENCON 2018-2018 IEEE Region 10 Conference. IEEE, 2018.
- [13] Kaya, Aydin, et al. Analysis of transfer learning for deep neural network based plant classification models. Computers and electronics in agriculture 158 (2019): 20-29.
- [14] Mkonyi, Lilian, et al. Early identification of Tuta absoluta in tomato plants using deep learning. Scientific African 10 (2020): e00590.
- [15] Fuentes, Alvaro, et al. A robust deep-learning-based detector for real-time tomato plant diseases and pests recognition. Sensors 17.9 (2017): 2022.
- [16] <https://www.kaggle.com/emmarex/plantdisease>

# An Analysis of the Applications of Natural Language Processing in Various Sectors

Priya B<sup>a,1</sup>, Nandhini J.M<sup>b</sup> and Gnanasekaran T<sup>c</sup>

<sup>a,1</sup> Associate Professor, Dept of CSE, Sri Sai Ram Engineering College, Chennai, India

<sup>b</sup> Associate Professor, Dept of IT, Sri Sai Ram Institute of Technology, Chennai, India

<sup>c</sup> Professor, R.M.K Engineering College, Chennai, India

**Abstract.** Natural Language processing (NLP) dealing with Artificial Intelligence concept is a subfield of Computer Science, enabling computers to understand and process human language. Natural Language Processing being a part of artificial intelligence provides understanding of human language by computers for the purpose of extracting information or insights and create meaningful response. It involves creating algorithms that transform text in to words labeling With the emerging advancements in Machine learning and Deep Learning, NLP can contributed a lot towards health sector, education, agriculture and so on. This paper summarizes the various aspects of NLP along with case studies associated with Health Sector for Voice Automated System, prediction of Diabetes Millets, Crop Detection technique in Agriculture Sector.

**Keywords.** Machine Learning, Deep Learnig, Artificial Neural Network

## 1. Introduction

NLP processes human language and produces computer understandable output or human understandable response as part of artificial intelligence application/implementation. NLP refers to a machine's ability to answer in a language that a human can understand. It is possible to build algorithms that convert text into words. The words can be classified based on their meanings. To extract meaning from human languages, most NLP techniques rely on machine learning. Linguistics and Computer Science are the two fields of NLP. Linguistics is the study of language, including its structure, grammar, meaning, and various types of phrases One of the fastest and far reaching emerging technology in Computer Science is the study of linguistics or natural language processing covering overlapping subject areas that include Machine Learning, Deep Learning and Artificial Intelligence.

---

<sup>1</sup> Priya. B, Associate Professor, Dept of CSE, Sri Sai Ram Engineering College, Chennai, India.  
E-mail:bpriya.cse@sairam.edu.in

## 2. Build Data Model

NLP spans over several levels and frequently these different levels integrate with one another as shown in Figure 1.

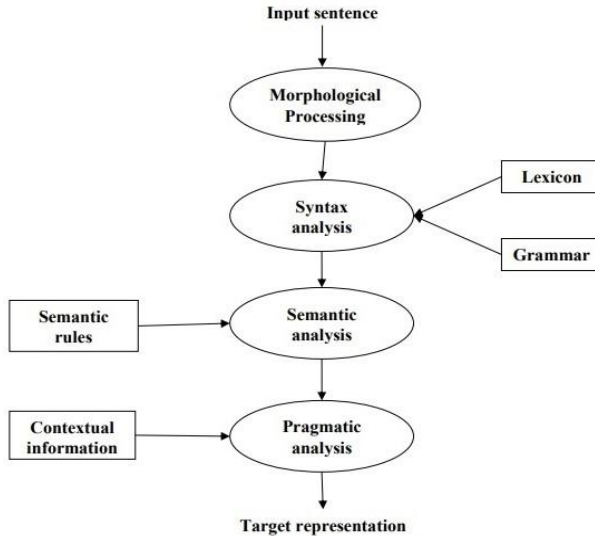


Figure 1. Levels of NLP

The various levels are

1. **Morphological level:** This level concerns with the study of word structures and formation of words, concentrating on the analysis of the individual components of words.
2. **Lexical Level:** The Lexical deals with the words and their lexical meaning. The processing at this level uses individual lexemes, an abstract unit of morphological analysis.
3. **Syntactic Level:** At the Syntactic level the output of the lexical analysis is used to cluster words into phrase and clause brackets. Phrase extraction is done at this level
- Semantic Level:** This level deals with the real meaning of the sentence by relating its syntactic features and disambiguating words with multiple definitions. It implicates the proper explanation of the meaning of sentences.
4. **Pragmatic Level:** The pragmatic level of linguistic analysis is concerned with the application of real-world experience and the comprehension of how this affects the communication meaning. A more detailed representation is obtained by analysing the contextual dimension of the documents and queries.

### 3. Challenges in NLP

In The complication of NLP is due to the essence of human language. The rules used for information communication using natural languages are not so easy for the computers as it is not easily understandable by it. Some rules can be high-level and abstract and some rules can be low-level. In wider sense, to understand the words of human language and its concept becomes essential to deliver the intended message. Natural language processing is difficult for computers to implement due to its complexity and imprecise features, although humans can easily master it.

### 4. Machine Learning and NLP

Machine Learning algorithms and Artificial Intelligence are used in Machine learning for NLP and text analytics to identify and understand the meaning of text documents. Machine learning and Artificial Intelligence has a major place in natural language processing and text analytics by improving, accelerating and automating the underlying text analytics functions as depicted in Figure 2.

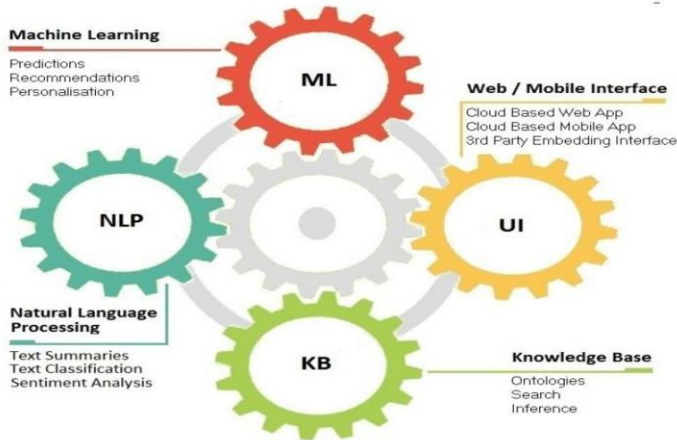


Figure 2: Machine Learning and NLP

The features of NLP can change the unstructured data into useable data. A machine learning model learns and updates from its training data. Machine learning for NLP and text analytics comprises a set of statistical techniques such as entities, sentiments and speech identification. ML and NLP have some overlay, as Machine Learning is often used for NLP tasks.

### 5. Deep Learning and NLP

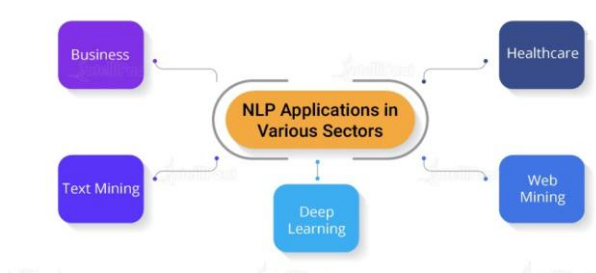
Deep learning for NLP is a branch of artificial intelligence that aids the computer in manipulating, and interpreting human language. Development of Computational algorithms in NLP is used for analysing and representing human languages using

machine learning and algorithmic approaches. Neural networks are the basis of Deep learning. Deep learning algorithms helps to solve problems in Natural Language Processing (NLP) that machine learning algorithms couldn't solve. The following are some of the most popular NPL applications that are made easier to solve with deep learning are

1. Text Classification and Categorization: In current scenario, text classification becomes important for many applications like web searching, email spam filtering, language identification, etc.
2. Named Entity Recognition (NER) : Named Entity Recognition (NER) is the first step for information extraction and entity classification.
3. Question Answering: The major applications of Natural Language Processing research is Question Answering. This application still remains as a challenge especially for search engines. NLP is used to create an interactive interface between human and computer. This is one of the most advanced features of deep learning-based NLP, in which people use a computer to find the answer to a specific question from a given text as input. This application would also improve website automated chat

## 6. Applications of NLP

Natural Language Processing is used in many fields. Many complex innovative applications using cutting edge technology falls under this category. The various sectors in which NLP is applied are given in Figure 3.



**Figure 3:** Application Sectors of NLP

Some of the popularly used NLP applications are:

- Machine Translation: The amount of knowledge available on the internet is growing at an exponential pace. NLP plays a significant role in meeting these requirements. By translating technical manuals, support documents, or catalogues at a significant expense, machine translation helps us resolve language barriers that are often encountered. The difficulty with machine translation technology isn't in interpreting sentences, but in comprehending them.
- Automatic summarization: Information overload is the real challenge , when a user has to access relevant information from a large knowledge base. Automatic summarization can be used to summarise the meaning of documents and records, as well as to comprehend the emotional meanings contained within the data. It's typically used to provide a high-level summary of a news storey or a series of blog posts while avoiding rhyming.

- **Sentiment Analysis:** NLP plays a vital role in monitoring social media. It's commonly used in sentiment analysis for a variety of purposes. The aim of sentiment analysis is to identify sentiments through several posts, or even within the same post, where emotion isn't always expressed directly. Many businesses use sentiment analysis to identify consumer views and sentiment online in order to help them develop better products.
- **Health Care:** Natural language processing helps to improve the completeness and accuracy of Electronic Health Records by transforming free text into standardized data. They examine patients' data to assess the implications of phenotyping, which is beneficial to doctors. Algorithms focused on natural language processing (NLP) identify possible errors in healthcare delivery. The NLP predictive analysis aids in the identification of high-risk patients, thus improving diagnostic procedures.
- **Text Mining:** The process of extracting high-quality information from text is known as Text Mining. It is also termed as text data mining. Text recognition, customer care, personalized bots, and sentiment analysis are examples of NLP applications in text mining.
- **Education:** NLP will parse and summarize arguments. It also assist authors in improving their writing and encouraging them to rewrite essays. Feedback to learners about the organization can be obtained from NLP. NLP solutions can be combined to create automated writing assessment (AWE) systems that can provide low-level feedback (Example: vocabulary tips) or higher-level feedback (Example, grammar corrections) (e.g., advice about the cohesion of discourse).
- **Agriculture:** Agriculture is highly important to global economy. With the continued growth of the human population, demand on the agricultural system is increasingly growing. Agri-technology and precision farming, collectively known as digital agriculture, have emerged as new scientific fields that employ data-intensive approaches to boost agricultural productivity while reducing environmental effects. Data obtained from a number of sensors in modern agricultural operations allows for a deeper understanding of the operating environment (an interaction of dynamic crop, soil, and weather conditions) as well as the process itself (machinery data), resulting in more precise and faster decision making.

## References

- [1] Sandeep Nigam; Ajit Kumar Das; Rakesh Chandra ,Machine Learning Based Approach To Sentiment Analysis, IEEE Xplore 2019.
- [2] Tom Young Devamanyu Hazarika; Soujanya Poria; Erik Cambria, Recent Trends in Deep Learning Based Natural Language Processing, IEEE Computational Intelligence Magazine Volume: 13, Issue: 3, Aug. 2018
- [3] M. Chandhana Surabhi, Natural language processing future, IEEE Xplore, 2013
- [4] Friedman C, Rindflesch TC, Corn M, Natural language processing: State of the art and prospects for significant progress, Journal of Biomedical Informatics, 25 Jun 2013, 46(5):765-773.
- [5] Krishna Prakash Kalyanathaya, D. Akila and P. Rajesh, Advances in Natural Language Processing – A Survey of Current Research Trends, Development Tools and Industry Applications, International Journal of Recent Technology and Engineering (IJRTE) ISSN: 2277- 3878, Volume-7, Issue-5C, February 2019
- [6] Denis, Design and Construction of a NLP Based Knowledge Extraction Methodology in the Medical Domain Applied to Clinical Information, Healthcare Informatics Research 2018;24(4): 376-380
- [7] Matthew N. O. Sadiku, Yu Zhou, and Sarhan M. Musa, Natural Language Processing, International Journal of Advances in Scientific Research and Engineering (IJASRE), Volume 4, Issue 5, May – 2018



# Malicious Attack Identification Using Deep Non Linear Bag-of-Words (FAI-DLB)

Dr.E.Arul<sup>a,1</sup>, A.Punidha<sup>b</sup>, K.Gunasekaran<sup>c</sup>, P Radhakrishnan<sup>c</sup>, VD Ashok Kumar<sup>d</sup>

<sup>a,1</sup> Assistant Professor, Department of IT, Coimbatore Institute of technology, Coimbatore, Tamilnadu, India

<sup>b</sup> Assistant Professor, Department of CSE, Coimbatore Institute of technology, Coimbatore, Tamilnadu, India

<sup>c</sup> Assistant Professor, Department of CSE, Panimalar Engineering College, Chennai, Tamilnadu, India

<sup>d</sup> Research Scholar, Department of CSE, St.Peter's University, Chennai, Tamilnadu, India

**Abstract.** Online media have flourished in modern years to connect with the world. Most of those stuff users share on blogs like facebook, twitter and many other are pessimistic or just middle spirited. Further, an increasingly professional anti - spyware technologies are dependent on Machine Learning(ML) technology to secure malicious consumers. Over the past few years, revolutionary learning approaches have yielded remarkable outcomes and have immediately generated photos, characters and text interpretations of dynamic weak points. The Purple consumer frequency makes the troll and attacker aim an enticing one. The users will learn the controversial topics and techniques used by malware from articles with ties to harmful material and bogus applications. It is essential to build and customize a lot of potential functionality in vulnerability and application developers around the world. To represent a public web firmware assault with deep logistic inference using Extreme Spontaneous Tree (FAI-DLB). A corresponding output device is named harmful or benign by training an FAI-DLB with different modulation clustered with such a normal or anomalous API. It was therefore equipped to locate a suspicious sequence in unidentified firmware of FAI Deep LB. The outcome demonstrates a good actual meaning of 96.25% and a low spyware assault of 0.03%.

**Keywords.** IoT, Backdoors, Malware, API calls, Deep Learning, Random Forest, Firmware

## 1. Introduction

The Malicious software is classified into many groups, depending on the manner the program is implemented as well as the direction it travels[12]. A virus or computer virus that is self replicated by exporting itself to another application. A Malware triggering

---

<sup>1</sup>Dr.E.Arul, Assistant Professor, Department of IT, Coimbatore Institute of technology, Coimbatore, Tamilnadu, India. E-mail: arulcitit@gmail.com

may be a harmful mail connection or an inexperienced person loading a Flash memory stick into a device. The machine is corrupted by the duplication of the malware. A Worm, malware that travels around the system by reproducing itself by user interference. Trojan a sort of ransom ware that resides in a java script code and runs on a device next to it. A Security hole malware that provides secret, permanent exposure to an undiscovered device, which unlocks the door to a machine with little manual intervention. Infectors of the file:Create mutual infections arrive to recognized file formats, such as.com or.exe. These are implemented when the programs are launched.

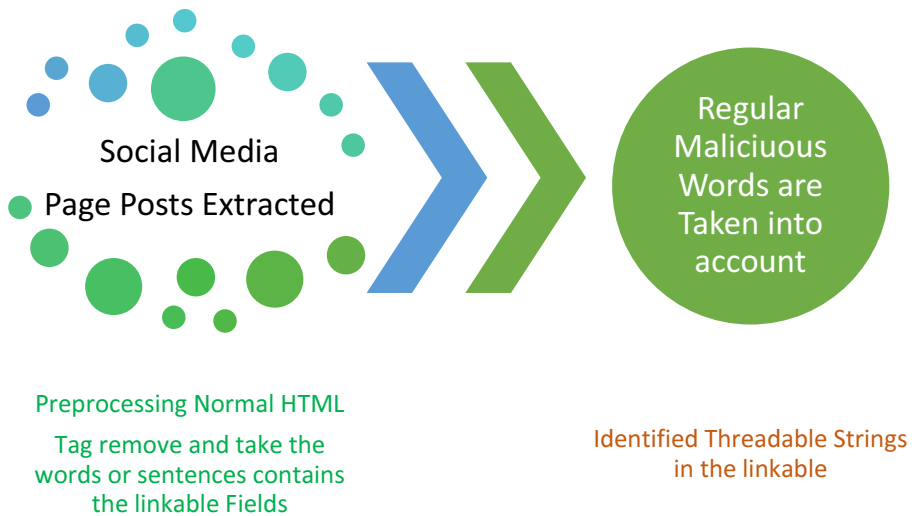
## 2. LITERATURE SURVEY

P. Dewan ,The increase in user engagement on online social networks ( OSNs) is seen as a consequence of a news case[1]. The computer hackers are using this drive to expand illegal code to destroy the reputation of the scheme, cause revenue damage and diminish user interface. The whole article established a number of community comments on instagram, produced over 4.4 million, and 11217 malevolent posts that included URLs. In eight headlines-making events (disaster warning, terrorist attacks etc.)[7], almost all of the offensive software that is actually trying to evade Facebook strategies has been discovered by third parties and web apps and about half of any and all quality content has been identified. The REST API and a browser-based plug-in are developed to detect suspicious posts on social media in near real - time.

R. J. Hada ,In recent years , social media growth has increased considerably when too many users visit social media across mobile media with the substantial emergence of knowledgeable smart phones and rapidly increasingly digital modern networks. A massive social networking site (OSN) on a database is always costly or even difficult to implement. Lateral scale up, where OSN is subdivided and distributed on a range of cheap servers, is an economical strategy. They are researching the issue of controlled segmentation of OSNs at minimal cost throughout this work. This blends the clusters accordingly and transfers clusters of the very same scale, thus raising the overall expense based on cross server traffic. We introduce and test all architectures on Twitter, Arxiv, tackle complex, Aim's solving wide range OSN repositories [4].

## 3. Delineation of Supervised Deep Learning Vector Quantization to Detect IoT Malware

A new of the tranquil runtime environments in NLP is its mock-up framework. It provides an illustrative template of both the document by monitoring every phrase's frequency of occurrence. It can be subsequently used as message clustering algorithm characteristics. For this template, you just consider particular terms and apply a particular moral relativism score for each term. In a vocabulary of feelings[12], this moral relativism value can be tested. If the overall score is negative, the text will be categorized as pessimistic and the message as beneficial. The written language and pronunciation are not taken into consideration. This is easy to make, but also less precise. This phrase provides the identical performance with unigrams, but never through the bigrams model + unigrams.



**Figure 1:** Delineation of the Fuzzy zip lock-of-words to identify fake links in social post

Indistinct logic is as followed to develop a classifier zip lock-of-words in various post present in the social media page.

- Fake\_List = [] ,For each review in the training set:
- Only at give up of each evaluation, deprive this same non - ascii character "vector" ,Place a space before and after each of the following characters: „,()[:;” (This prevents sentences like “I like this book.It is engaging” being interpreted as [“Click”, “Post”, “Share”, “Install It”, “Lucky”, “love you”].)
- Divide into gaps, categorize the file. Erase trinkets that are only a platform, vacant pair, or dot label.
- For Fake\_List, add the keys. Already Fake\_List includes the entire set of parameters.
- In JavaScript response item, spot list Fake\_List. This monitor currently includes both terms and their coefficients. The utmost collective function can also be used to sort your posts.

This pattern concentrates solely on terms, or often on a sequence of words, but typically fails to answer the so called "framework." The method term bag generally includes a wide list which is typically best understood as a kind of "directional," which have been regarded as experiencing words. Each of these phrases has its own "importance" in document. Usually the factors are all incorporated, resulting in a perception evaluation. There are several different equations to attach and extract, however this template concentrates mostly on terms and doesn't try to grasp the function of knowledge actually.

#### 4. EXPERIMENTAL RESULTS AND COMPARISON

This template tries to make the computer recognize the frameworks, meaning of the statements and concentrates a little more on progression of a series. Typically, the computer needs to grasp the grammatical structures in this framework[24]. The natural language processing (NLP) technology for this purpose is used to tag parts of the language, named entities or more. It is not to search only for target words to truly understand the 'language' of the text. With using a tagger or an encoding template, it is essential to clarify the corpus for stand. The further terms, more and more papers are represented, and so it is necessary to minimize the words to those that are assumed to be significant predictors. This is not easy to learn and sometimes various theories about developing an using of this must be checked. It can build in table 1 a repertoire as a reference, a database that makes it easy to check terms and their counters. The studies illustrate that we already have a 55,125 choosing the right words. Within the opinion pieces, we can even see a list of the best 50 words. Remember that even these comments in the test set were focused on another terminology.

During the analysis it is found that the frequency of matching word in different malicious posts were given as follows:

[('<a>', 1213), ('share', 2146), ('click', 4826), ('like', 3201), ('sh', 2262), ('exe', 2080), ('time', 4321), ('<iframe>', 1107), ('love click', 1873), ('offer', 1844), ('best', 1824), ('tick', 5452), ('like', 1735), ('get', 1214), ('character', 1233), ('my show', 5453), ('level', 5523), ('see', 4212), ('way', 3243), ('cricket', 5642), ('score', 1231), ('really', 4534), ('book', 2133), ('threat', 1233), ('plot', 1288), ('people', 3219), ('could', 1248), ('new', 1248), ('scene', 1241), ('download', 1238), ('never', 1201), ('best', 4323), ('update', 4321), ('songs', 1135), ('man', 4241), ('many', 1321), ('doesn't', 4323), ('know', 1092), ('dont', 1421), ('hes', 1024), ('great', 1014), ('another', 992), ('action', 985), ('love', 977), ('us', 3212), ('go', 952), ('enter', 3213), ('age', 321), ('group', 678), ('pills', 567)].

The algorithm resolves documentation in the terminology and delete all small incidence terms along with once maybe twice in all comments. For instance, just the signatures which occur 2 or even more times in every analysis can be outlined in the following excerpt. By using the instance described with for this inclusion, the language is reduced from 55,125 to 32,121 words by either a little over twice its duration. This represents a much more expressionistic document than conventional techniques such as bag-of-words, where connections among both phrases are overlooked or compelled into bigrams or trigrams.

**Table 1.** Suggested Interpretations Deep Zip-Lock against known malicious strategies

Methods	Amount of Uncoveringof hazard files	Exact Quantity (%)	Imprecise Professed	Imprecise SupposedPart (%)
P. Dewan	923	83.75	179	0.13
R. J. Hada	991	89.92	111	0.08
Proposed SM-DLB	1073	97.36	29	0.02

## 5. CONCLUSION AND FUTURE WORK

In social networking sites like: Facebook, Google +, and other users in Twitter, manipulative attack can be used. Many of these participants really are not customers, partners or experienced men. The goal is to harm the entity or the organization clearly. The bulk of injected vulnerabilities into another computer system utilize some popular social networking, Platform-related calls to execute recognized suspicious attacks. The Trojan grabs your personal data and sends it over to the cyber database, distributes suspicious phishing, and uses the full maximum throughput of any framework. The cropping up used explicitly for malevolent as well as grouped API security software calls performing spamware procedure in this future framework. A FAI-DLB training set has been used finally to verify whether some harmful commands have more similarities. The consequence is a real positive result of 97.36% of the different social network software assaults and a fake certainly develop rating of 0.02%. In long term, the whole process will be completed with different APIs that enables malevolent systems integration.

## References

- [1] P. Dewan and P. Kumaraguru, "Towards automatic real time identification of malicious posts on Facebook," 2015 13th Annual Conference on Privacy, Security and Trust (PST), Izmir, 2015, pp. 85-92, doi: 10.1109/PST.2015.7232958.
- [2] J. Zhang, B. Dong and P. S. Yu, "Deep Diffusive Neural Network based Fake News Detection from Heterogeneous Social Networks," 2019 IEEE International Conference on Big Data (Big Data), Los Angeles, CA, USA, 2019, pp. 1259-1266, doi: 10.1109/BigData47090.2019.9005556.
- [3] R. J. Hada, H. Wu and M. Jin, "Scalable Minimum-Cost Balanced Partitioning of Large-Scale Social Networks: Online and Offline Solutions," in IEEE Transactions on Parallel and Distributed Systems, vol. 29, no. 7, pp. 1636-1649, 1 July 2018, doi: 10.1109/TPDS.2017.2694835.
- [4] Kakisim, Arzu, Nar, Mert&Sogukpinar, Ibrahim ". Metamorphic malware identification using engine-specific patterns based on co-opcode graphs" Computer Standards & Interfaces. 2020. doi:71. 103443. 10.1016/j.csi.2020.103443.
- [5] Miserendino, Scott, Peters, Ryan, Klein, Robert, Kaloroumakis, Peter. "System and method for in-situ classifier retraining for malware identification and model heterogeneity.", US20200401941, 2018
- [6] Irofti, Paul, Băltoiu, Andra. "Malware Identification with Dictionary Learning", 2019.. doi:10.23919/EUSIPCO.2019.8903043.
- [7] Chen, Rong, Li, Yangyang, Fang, Weiwei. "Android Malware Identification Based on Traffic Analysis", 2019. doi:10.1007/978-3-030-24274-9\_26.
- [8] Luo, Xiong, Li, Jianyuan, Wang, Weiping, Gao, Yang, Zhao, Wenbing. "A Malware Identification and Detection Method Using Mixture Correntropy-Based Deep Neural Network", 2019. doi:10.1007/978-981-15-1922-2\_23.
- [9] Miserendino, Scott & Peters, Ryan & Klein, Robert & Kaloroumakis, Peter. (2018). System and method for in-situ classifier retraining for malware identification and model heterogeneity.
- [10] Lopes, Joao, Serrao, Carlos, Nunes, Luis, Almeida, Ana, Oliveira, Joao. "Overview of machine learning methods for Android malware identification", pp 1-6., 2019. doi:s 10.1109/ISDFS.2019.8757523.
- [11] Hussain, Syed, Ahmed, Usman, Liaquat, Humer, Mir, Shib, Zaman, Noor, Humayun, Mamoon, "Intelligent Malware Identification for Android Platform" pp: 1-6., 2019 doi:10.1109/ICCIsci.2019.8716471.
- [12] Sharma, Anshul& Singh, Sanjay. "A novel approach for early malware detection. Transactions on Emerging Telecommunications Technologies".2021. doi.10.1002/ett.3968.

# Detection of Network Attacks Based on Multiprocessing and Trace Back Methods

Vijayakumar R<sup>a,1</sup>, Vijay K<sup>b</sup>, Sivaranjani P<sup>b</sup> and Priya V<sup>c</sup>

<sup>a,b</sup>*Assistant Professor, Department of CSE, Rajalakshmi Engineering College, Chennai, India*

<sup>c</sup>*Assistant Professor, Department of CSE, PSNA College of Engg and Technology, Dindigul, India*

**Abstract:** The way of thinking of traffic observing for discovery of system assaults is predicated on a "gained information" viewpoint: current methods recognize either the notable assaults which they're customized to alarm on, or those strange occasions that veer off from a known typical activity profile. These philosophies depend on an expert structure which gives the ideal data, either with respect to "marks" of the striking attacks or as anomaly free traffic datasets, adequately rich to make delegate profiles for commonplace movement traffic. The theory talks about the limitations of current information-based system to recognize organize assaults in an inexorably unpredictable and advancing Web, Described by ever-rising applications and an ever-expanding number of most recent system assaults. In an oppositely inverse viewpoint, we place the weight on the occasion of solo recognition strategies, fit for distinguishing obscure system assaults during a unique situation with none past information, neither on the attributes of the assault nor on the gauge traffic conduct. In view of the perception that an outsized portion of system assaults are contained during a little division of traffic flows, the proposition exhibits an approach to join basic bunching strategies to precisely distinguish and portray malignant flows. to bring up the practicality of such an information autonomous methodology, a solid multi-bunching-based location technique is created and assess its capacity to recognize and portray arrange assaults with none past information, utilizing bundle follows from two genuine operational systems. The methodology is acclimated identify and describe obscure vindictive flows, and spotlights on the identification and portrayal of ordinary and notable assaults, which encourages the translation of results. When contrasted with the predominant DDoS traceback techniques, the proposed system has assortment of favorable circumstances—it is memory no concentrated, proficiently adaptable, vigorous against parcel contamination, and free of assault traffic designs. The consequences of inside and out test and reenactment considers are introduced to exhibit the adequacy and effectiveness of the proposed strategy. It's an uncommon test to traceback the wellspring of Circulated Disavowal of-Administration (DDoS) assaults inside the Web. In DDoS assaults, aggressors create a lot of solicitations to casualties through undermined PCs (zombies), with the point of keeping ordinary help or debasing from getting the norm of administrations. Because of this fundamental change, the proposed system conquers the acquired downsides of parcel stamping strategies, similar to weakness to bundle contaminations. The execution of the proposed strategy welcomes no changes on

---

<sup>1</sup>Vijayakumar R, Assistant Professor, Department of CSE Rajalakshmi Engineering College, Chennai, India. vijay.k@rajalakshmi.edu.in

current steering programming. Moreover, this work builds up a hypothetical structure for assessing the insurance of IDS against mimicry assaults. It shows an approach to break the wellbeing of 1 distributed IDS with these strategies, and it tentatively affirms the capacity of various assaults by giving a worked model. The Project is intended by using Java 1.6 as face and MS SQL Server 2000 as backside. The IDE used is Net Beans 6.8.

**Keywords:** attacks; DDos; Dos; Trackback;

## 1. Introduction

System traffic checking has become a fundamental method for recognition of system assaults in the present Web. The chief test in recognizing system assaults is that these are a moving objective. It is beyond the realm of imagination to expect to know the various assaults that an aggressor may dispatch, in light of the fact that new assaults just as new variations of definitely realized assaults are consistently rising. Without a doubt, assaults have become both progressively various and refined throughout the long term. Two distinct methodologies are by a wide margin prevailing in ebb and flow research network and business recognition frameworks: signature-based location and peculiarity discovery. Regardless of being inverse in nature, the two methodologies share a typical drawback: they depend on the information gave by a specialist framework, generally a human master, to carry out the responsibility. We will hence allude to them as information-based identification draws near. From one viewpoint, signature-put together discovery frameworks are based with respect to a broad information on the specific attributes of each assault, alluded to as its "signature". Such frameworks are exceptionally successful to identify those notable assaults which they are customized to caution on. Regardless, they can't watch the framework against new attacks, just considering the way that they can't see what they haven't the foggiest. Likewise, assembling new marks includes manual review by human specialists, which isn't without a doubt, extravagant and inclined to blunders, yet additionally presents a significant inertness between the revelation of another assault and the development of its mark. In a system situation where, new assaults are continually showing up, such a manual cycle forces a genuine bottleneck on the guard abilities of the system. Then again, irregularity recognition depends on the presence of ordinary activity traffic examples to fabricate a pattern profile, recognizing inconsistencies as traffic exercises that stray from it. Such a methodology grants to distinguish new sorts of system assaults not seen previously, in light of the fact that these will normally go amiss from the developed standard.

Persuaded by the restrictions of information-based methodologies, another examination zone has developed in the most recent years, in light of an oppositely inverse way of thinking for location of bizarre traffic occasions: Unaided Oddity Discovery. Current bunch examination procedures: the absence of heartiness.

## 2. Literature Survey

DDoS attacks are engaged at crippling the setback's benefits, for instance, organize move speed, preparing force, and working system data structures. To dispatch a DDoS

ambush, the attacker(s) first develops an arrangement of PCs that will be used to make the tremendous volume of traffic expected to decline any help to genuine customers of the individual being referred to. To cause this attack to orchestrate, aggressors find frail hosts on the framework. Frail hosts data on attack can be appointed follows: allowance subject to fragmentary information [5], certifiable framework mimicking [6] or reenactments [7], and veritable ambush and security between two organize assessments packs.

Plainly chasing down the aggressors (zombies), and further to the developers, is basic in understanding the attack challenge. The rundown of the current DDoS traceback strategies can be found in [3] and [4]. With everything taken into account, the traceback approaches rely upon package checking.

Pack checking procedures join the PPM and the DPM. The PPM framework endeavors to check groups with the switch's IP address information by probability on the close by switch, and the setback can reproduce the manners in which that the ambush bundles experienced. The PPM procedure is powerless against aggressors, as raised in [1], as attackers can send personification stepping information to the setback to bamboozle the individual being referred to. The precision of PPM is another issue in light of the fact that the stepped messages by the switches who are closer to the leaves (which suggests far away from the individual being referred to) could be overwritten by the downstream switches on the attack tree [2].

### 3. System Assaults

Despite the fact that we guarantee that our methodology can be utilized to identify and describe obscure malevolent streams, we center on the location and portrayal of standard and notable assaults, which encourages the understanding of results. Notwithstanding, we will accept no past information about these assaults, and in this manner treat them as totally obscure. Refusal of Administration (DoS), organize examines, Circulated DoS (DDoS), and worms' engendering are instances of standard assaults that day by day compromise the respectability and ordinary activity of the system.

#### 3.1 *DDoS/DoS*

A DDoS/DoS assault is an endeavor to make a system asset (a specific help, arrange data transmission, and so on.) inaccessible to its expected (real) clients. In its most broad structure, a DoS/DDoS assault holds onto assets by utilizing or mentioning beyond what the casualty can deal with, keeping it from reacting to authentic solicitations.

#### 3.2 *Worms spread*

A worm [8] is a malevolent self-duplicating program that utilizes the system to send duplicates of itself, contaminating different machines by misusing explicit weaknesses. A worm is typically used to introduce a secondary passage in the tainted PC, permitting the production of a "zombie" machine heavily influenced by the assailant. Systems of such machines are alluded to as "botnets", and are commonly used to dispatch enormous DDoS assaults.



### 3.3 System check

A system check [9] is a testing endeavor to distinguish the accessibility of a particular help on a wide range of machines. Distinguishing framework inspects is basic considering the way that such a development is commonly a predecessor of the expansion of a worm, and along these lines the harbinger of possible DDoS attacks. Framework checks are depicted by a lone source sending traffic to various complaints.

### 3.4 Sub-Space Grouping and Proof Gathering

The solo identification and portrayal calculation starts in the subsequent stage, utilizing as info the arrangement of streams caught in the abnormal space. An inconsistency is commonly recognized in various accumulation levels, and there are numerous heuristics to choose a specific conglomeration to use in the solo stage; for straightforwardness we will skirt this issue, and utilize any of the total levels where the irregularity was distinguished. Without loss of consensus, let  $Y = \{y_1, \dots, y_n\}$  be the arrangement of  $n$  streams in the hailed opening. Each stream  $y_i$  to  $Y$  is portrayed by a lot of  $m$  traffic qualities or highlights. The rundown incorporates standard and essential traffic qualities, which grants to portray the distinguished assaults in simple to-decipher terms portrayal results.

Let  $x_i = (x_i(1), \dots, x_i(m))$  be the comparing vector of  $m$  traffic highlights portraying stream  $y_i$ , and  $X = \{x_1, \dots, x_n\}$  the total framework of highlights, alluded to as the component space.

## 4. Results and Discussions

We assess the capacity of the solo calculation to recognize and to build a mark for various assaults in genuine rush hour gridlock follows from the open traffic vault of the WIDE undertaking. The WIDE operational system gives interconnection between various exploration foundations in Japan, just as association with various ISPs and colleges in the U.S..

### 4.1 Detecting Network Scan

Distinguishing a system filter initially recognize and portray a dispersed SYN organize examine coordinated to numerous casualty has under the equivalent/16 objective system. Parcels in  $Y$  are amassed in IPdst/24 streams, in this way we will distinguish the assault as a little size bunch.

The length of each opening is  $T = 20$  seconds. As we clarified in segment III-A, the SSC-EA-based bunching calculation builds another comparability measure between streams in  $Y$ . We will communicate this new similitude measure as a  $n \times n$  network  $S$ , in which component  $S(x, y)$  speaks to the level of closeness between streams  $x$  and  $y$ .

### 4.2 Detecting a Distributed DoS attack

Figure 1.(a,b) delineate various standards acquired in the identification of a SYN DDoS assault. Traffic is currently accumulated in Ipsrc/32 streams, and the assault is

identified as a little size group. The examination of between streams likeness w.r.t. S chooses a minimal separated bunch, comparing to the arrangement of assaulting has. The acquired mark can be communicated as  $(nDsts == 1) \wedge (nSYN/nPkts > 3) \wedge (nPkts/sec > 4)$ , which joined with the huge number of distinguished sources ( $nSres > 5$ ) affirms the idea of a SYN DDoS assault.

### 4.3 Detecting outliers attacks

On account of exception's recognition, the comparability measure gave by the SSC-EA-based calculation doesn't speak to between streams closeness; rather, it relates to the combined detachment of an anomaly to the greatest bunch in the distinctive sub-spaces. Let us first present the location of a SYN organize filter and an ICMP flooding assault utilizing the SSC-EA-based exception's recognition approach. Traffic is totaled in IPsrc/32 streams. Figure 1. shows the arranged divergence esteems acquired for the various streams, alongside their relating grouping.

The initial two most inaccessible streams compare to a profoundly appropriated SYN organize examine (in excess of 500 objective hosts) and an ICMP mock flooding assault coordinated to few casualties (ICMP divert traffic, coordinated towards port 0).

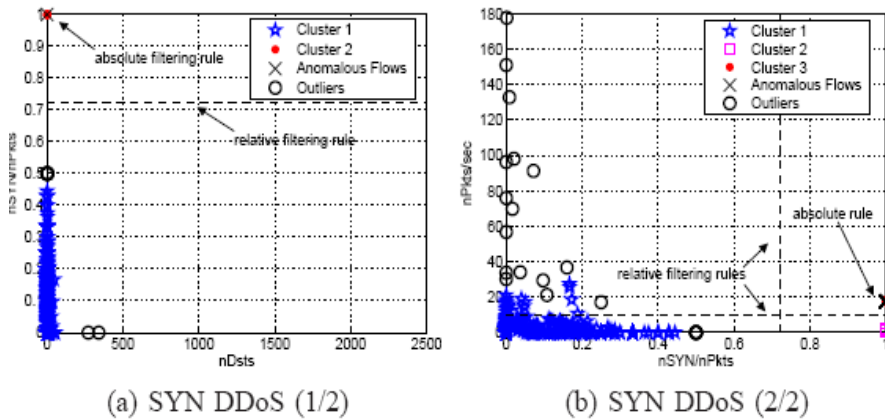


Figure 1 – SYN DDoS

## 5. Conclusion and Future Scope

In this work I question the capacity and stress the restrictions of current information-based methodologies for identification of system assaults, especially with regards to an undeniably intricate and ever-advancing Web. In an oppositely inverse viewpoint, I place the accentuation on the improvement of unaided, information autonomous discovery calculations, which I accept is the following common advance in organize traffic observing for arrange security. As a proof-of-idea of how such a recognition approach could be really executed in the training, I have delineated a strong multi-grouping-based identification technique and assessed its capacity to identify and portray standard system assaults with no past information, utilizing bundle follows from two genuine operational systems.

## References

- [1] Wang.H, Jin.C and Shin.K.G, Defense against Spoofed IP Traffic Using Hop-Count Filtering, *IEEE/ACM Trans. Networking*, vol. 15, no. 1, pp. 40-53, Feb. 2007.
- [2] K. Lu et al., Robust and Efficient Detection of DDoS Attacks for Large-Scale Internet, *Computer Networks*, vol. 51, no. 9, pp. 5036-5056, 2007.
- [3] Kompella.R.R, Singh.S, and Varghese.G. On Scalable Attack Detection in the Network, *IEEE/ACM Trans. Networking*, vol. 15, no. 1, pp. 14-25, Feb. 2007.
- [4] Ayres.P.E et al., ALPi: A DDoS Defense System for High-Speed Networks, *IEEE J. Selected Areas Comm.*, vol. 24, no. 10, pp. 1864-1876, Oct. 2006.
- [5] R. Chen, J. Park, and R. Marchany, A Divide-and- Conquer Strategy for Thwarting Distributed Denial-of- Service Attacks, *IEEE Trans. Parallel and Distributed Systems*, vol. 18, no. 5, pp. 577-588, May 2007.
- [6] A. Yaar, A. Perrig, and D. Song, StackPi: New Packet Marking and Filtering Mechanisms for DDoS and IP Spoofing Defense, *IEEE J. Selected Areas Comm.*, vol. 24, no. 10, pp. 1853-1863, Oct. 2006.
- [7] R. Vijayakumar, K. Selvakumar, K. Kulothungan and A. Kannan, Prevention of multiple spoofing attacks with dynamic MAC address allocation for wireless networks , 2014 International Conference on Communication and Signal Processing, Melmaruvathur, 2014, pp. 1635-1639, doi: 10.1109/ICCSP.2014.6950125.
- [8] S. Fei, L. Zhaowen and M. Yan, A survey of internet worm propagation models, 2009 2nd IEEE International Conference on Broadband Network & Multimedia Technology, Beijing, 2009, pp. 453-457, doi: 10.1109/ICBNMT.2009.5348534.
- [9] Hong.Q, T. Jianwei, Y. Ying, T. Zheng, Z. Hongyu and L. Shu, A Network Scanning Detection Method Based on TCP Flow State, 2018 3rd International Conference on Smart City and Systems Engineering (ICSCSE), Xiamen, China, 2018, pp. 419-422, doi: 10.1109/ICSCSE.2018.00089.
- [10] Ambeth Kumar.V.D et.al.,Performance Improvement Using an Automation System for Segmentation of Multiple Parametric Features Based on Human Footprint.for the Journal of Electrical Engineering & Technology , vol. 10, no. 4, pp.1815-1821 , 2015. [<http://dx.doi.org/10.5370/JEET.2015.10.4.1815>]
- [11] Ambeth Kumar.V.D et.al. A Survey on Face Recognition in Video Surveillance. *Lecturer Notes on Computational and Mechanism*, Vol. 30, pp: 699-708, 2019
- [12] Ambeth Kumar.V.D .Precautionary measures for accidents due to mobile phone using IOT. *Clinical eHealth*, Volume 1, Issue 1, March 2018, Pages 30-35.
- [13] Ambeth Kumar.V.D et.al, Enhancement in Footprint Image using Diverse Filtering Technique” *Procedia Engineering journal*, Volume 8, No.12, 1072-1080, 2012 . [doi:10.1016/j.proeng.2012.01.965]
- [14] Nanagasabapathy.K et.al. Validation system using smartphone luminescence.IEEE International Conference on Intelligent Computing, Instrumentation and Control Technologies (ICICT), Pages: 235 – 239, 6-7 July 2017, Kannur, India
- [15] B. Aravindh et.al, A novel graphical authentication system for secure banking systems.IEEE International Conference on Smart Technologies and Management for Computing, Communication, Controls, Energy and Materials, Pages: 177 – 183, 2-4 Aug. 2017, Vel Tech University, Chennai, India
- [16] S.V. Rupitha et.al. Management of Major Postpartum Haemorrhage by using Zigbee protocol - A Review .2021 6th International Conference on Inventive Computation Technologies (ICICT) (DOI: 10.1109/ICICT50816.2021.9358757 )
- [17] Indhumathi.M et.al .Healthcare Management of Major Cardiovascular Disease-A review. 2021 6th International Conference on Inventive Computation Technologies (ICICT), (DOI: 10.1109/ICICT50816.2021.9358519 )
- [18] Ambeth Kumar.V.D et.al. Cloud enabled media streaming using Amazon Web Services. IEEE International Conference on Smart Technologies and Management for Computing, Communication, Controls, Energy and Materials, Pages: 195 – 198, 2-4 Aug. 2017, India (DOI: 10.1109/icstm.2017.8089150)
- [19] Ambeth Kumar.V.D et.al, (2016).An Efficient Security System for Data base Management from Illegal Access, IEEE International Conference on Wireless Communications, Signal Processing and Networking (WiSPNET), SSN Engineering College, Chennai, India, 23-25 March, 2016

# MRI Image Classification of Brain Tumor Using Deep Neural Network and Deployment Using Web Framework

Sumithra M<sup>a,1</sup>, Shruthi S<sup>b</sup>, SmithiRam<sup>b</sup>, Swathi S<sup>b</sup>, Deepika T<sup>b</sup>

<sup>a</sup>Associate Professor, Panimalar Engineering College, Chennai

<sup>b</sup>UG scholar, Panimalar Engineering College, Chennai

**Abstract:** A brain tumor is a mass or growth of abnormal cells in our brain. Many different types of brain tumors exist. Some brain tumors are noncancerous (benign), and some brain tumors are cancerous (malignant). Brain tumors can begin in your brain (primary brain tumors), or cancer can begin in other parts of your body and spread to your brain (secondary, or metastatic, brain tumors). Brain tumor treatment options depend on the type of brain tumor you have, as well as its size and location. The classification of brain tumors is performed by biopsy, which is not usually conducted before definitive brain surgery. The improvement of technology and machine learning can help radiologists in tumor diagnostics without invasive measures. A machine-learning algorithm that has achieved substantial results in image classification is the convolution neural network (CNN). It is predicted that the success of the obtained results will increase if the CNN method is supported by adding extra feature extraction methods and classify successfully brain tumor normal and abnormal image.

**Keywords:** brain tumor, deep learning, Tensor Flow, CNN

## 1. Introduction

The classification of brain tumors is performed by biopsy, which is not usually conducted before definitive brain surgery. The improvement of technology and machine learning can help radiologists in tumor diagnostics without invasive measures[6]. A machine-learning algorithm that has achieved substantial results in image segmentation and classification is the convolutional neural network (CNN). The classification was performed using a T1-weighted contrast-enhanced MRI image database which contains three tumor types. As input, we used whole images, so it was not necessary to perform any preprocessing or segmentation of the tumors[7],

---

<sup>1</sup> Sumithra M, Associate Professor, Panimalar Engineering College, Chennai,  
Email: sumithram.id@gmail.com

Samples of more number of images are collected that comprised of different classes such as normal and abnormal. Different number of images is collected for each class that was classified into input images. we proposed a Deep Learning (DL) based brain tumor prediction method to prevent disease by cultivating. The DL method used in the study is the Convolution Neural Network (CNN)[10]. It is predicted that the success of the obtained results will increase if the CNN method is supported by adding extra feature [8]extraction methods and classify successfully brain tumor. To deployment these processes by show the prediction result in local host web application.

## 2. Architecture

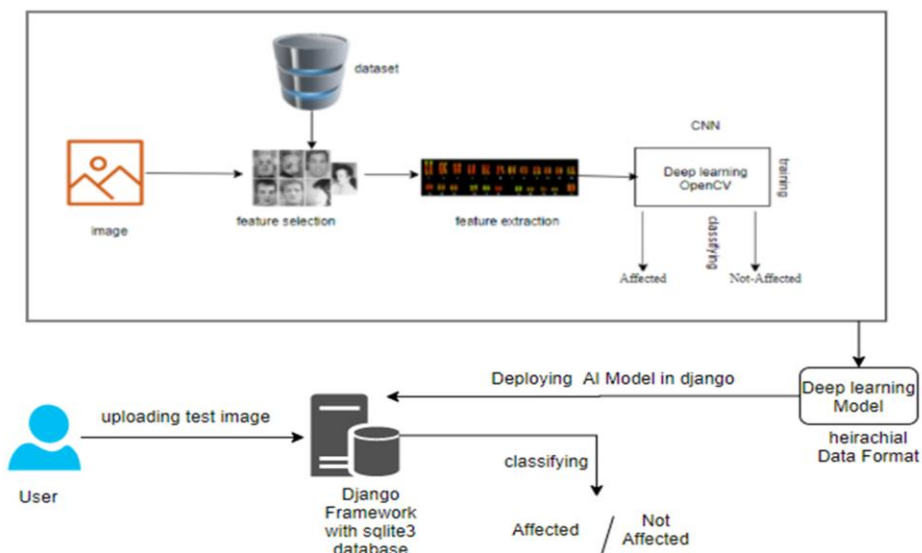


Figure 1. Architecture Diagram

The images which are both tumorous and non-tumorous are trained in the dataset using deep learning algorithm. When the user uploads a new image, it can easily identify whether the image is tumorous or not using the trained dataset. It is done in Django framework with slight 3 database. The user uploads the image in .h5 format (hierarchical data format[9]) which is the supported format in the python framework.

## 3. Methodology

### 3.1 Loading the given Brain Tumor image (module01)

The data set is imported using keras preprocessing image data generator function also we create size, rescale, range, zoom range, horizontal flip. Then we import our image dataset from folder through the data generator function. Then we make folders as train, test, and validation also we set target size, batch size and class-mode from this function we have to train of brain tumor.

### 3.2 Training the given Tumor image using Convolution Neural Network(module02)

The dataset that is the images brain tumor and normal is collected and the LeNet CNN is applied on the model and the accuracy and graph is collected.

### 3.3 Working of the Algorithm and .h5 file generation (module03)

In this module we train the neural network by giving the images by giving more epochs to train better and the .h5 file (Hierarchical Data Format) is generated and the model is loaded and is tested by giving input.

### 3.4 Deployment of brain tumor model in Django Framework and predicting output (module04)

In this module we create a web application using Django framework by using sqlite3 database. Our .h5 file is deployed in the web application here the image is uploaded and after uploading the model predicts whether the giving image has tumor or not.

## 4. Conclusion

It focused how image from given dataset (trained dataset) in field and past data set used predict the pattern of brain tumor using CNN model. This brings some of the following insights about tumor prediction. We had applied different type of CNN compared the accuracy and saw that LeNet makes better classification and the .h5 file is taken from there and that is deployed in Django framework for better user interface.

## References

- [1] MirceaGurbin, MihaelaLascu, Dan Lascu .Tumor Detection and Classification of MRIBrain Image using Different Wavelet Transforms and Support Vector Machines. 2019 42ndProcessing (TSP), Budapest,Hungary, 2019, pp. 505-508.
- [2] M. Rezaei, H. Yang, C. Meinel .Instance Tumor Segmentation using Multitask Convolutional Neural Network.2018 International Joint Conference on Neural Networks (IJCNN), Rio de Janeiro, 2018, pp. 1-8.
- [3] HarshiniBadisa, MadhaviPolireddy, Aslam Mohammed.CNN Based Brain Tumor Detection, International Journal of Engineering and Advanced Technology (IJEAT), Volume-8 Issue-4, April 2019, pp. 1731 – 1734.
- [4] MB Bramarambika, Seshashayee .Brain Tumor Detection and Identification Using Histogram Method. International Journal of Innovative Technology and Exploring Engineering (IJITEE), Volume-8 Issue-10, August 2019, pp. 3517 – 3521.
- [5] TonmoyHossain, FairuzShadmaniShishir, Mohsena Ashraf, MD Abdullah Al Nasim,Faisal Muhammad Shah.Brain Tumor Detection Using Convolutional Neural Network. 1st International Conference on Advances in Science, Engineering and Robotics Technology 2019(ICASERT 2019), Dhaka, Bangladesh, 2019, pp. 1-6.
- [6] Sumithra.M and Malathi.S.Segmentation Of Different Modalities Using Fuzzy K-Means And Wavelet ROI.International Journal Of Scientific & Technology Research, Volume 8, Issue 11, pp. 996-1002, November 2019. (18302 oct excel scopus list)
- [7] Sumithraand.M, Malathi.S .A Brief Survey on Multi Modalities Fusion.Lecture Notes on Data Engineering and Communications Technologies, 35, pp. 1031-1041,2020.
- [8] Sumithra.M and Malathi.S .Modified Global Flower Pollination Algorithm-based image fusion for medical diagnosis using computed tomography and magnetic resonance imaging. International Journal of Imaging Systems and Technology.Vol. 31, Issue No.1, pp. 223-235, 2021.

- [9] Sumithra.M and Malathi.S .A survey on Medical Image Segmentation Methods with Different Modalities. International Journal of Engineering Research and Technology (IJERT) – Volume 6 Issue 2, Mar 2018.
- [10] Sumithra.M and Malathi.S .A Survey of Brain Tumor Segmentation Methods with Different Image Modalities. International Journal of Computer Science Trends and Technology (IJCT) – Volume 5 Issue 2, Mar – Apr 2017.
- [11] Ambeth Kumar.V.D et.al .A Comparative Study of Fuzzy Evolutionary Techniques for Footprint Recognition and Performance Improvement using Wavelet based Fuzzy Neural Network.for the International Journal of Computer Applications in Technology, Vol.48, No.2,pp.95 – 105, [ <http://dx.doi.org/10.1504/IJCAT.2013.056016>]
- [12] Ambeth Kumar.V.D et.al .Gender Identification Using a Speech Dependent Voice Frequency Estimation System.International Journal of Computer Science and Information Security,, Vol 14, No: 11, PP: 1025-1034, 2016.
- [13] Venkatesh.J, Ambeth Kumar.V.D.Advanced Filter and Minutia Matching For Fingerprint Recognition. in the month of January for International Journal of Science and Research (IJSR), Volume 2 Issue 1 January 2013
- [14] Ambeth Kumar.V.D, Dr.M.Ramakrishan and G.Jagdeesh (2012).A Discrete correlation of Footprint Image aforementioned to Recognition. in the month of March for the 1st National Conference on Future Computing 2012 (FUCOMPU),March , 2012.Pondichery University , (karaikal Branch) Karaikal
- [15] Ambeth Kumar.V.D et.al..Performance Improvement Using an Automation System for Segmentation of Multiple Parametric Features Based on Human Footprint.for the Journal of Electrical Engineering & Technology , vol. 10, no. 4, pp.1815-1821 , 2015. [<http://dx.doi.org/10.5370/JEET.2015.10.4.1815>]
- [16] Ambeth Kumar.V.D and Ramakrishan.M(2011).Web Cam Motion Detection Surveillance System Using Temporal Difference and Optical Flow Detection with Multi Alerts.(CCIS) Journal (Springer) Volume 147, Part 3,pp: 214-221, 2011, April 2011 and the paper was published in the International Journal. [Impact Factor: 0.247],[DOI: 10.1007/978-3-642-20573-6\_34]
- [17] Ruphitha.S.V et.al.Management of Major Postpartum Haemorrhage by using Zigbee protocol - A Review. 2021 6th International Conference on Inventive Computation Technologies (ICICT) (DOI: 10.1109/ICICT50816.2021.9358757 )
- [18] M. Indhumathi et.al .Healthcare Management of Major Cardiovascular Disease-A review. 2021 6th International Conference on Inventive Computation Technologies (ICICT), (DOI: 10.1109/ICICT50816.2021.9358519 )
- [19] Sabarinathan.K et.al . Machine Maintenance Using Augmented Reality. 3rd International Conference on Communication and Electronics Systems (ICCES), 2018. (DOI: 10.1109/CESYS.2018.8723900)
- [20] R. Subha Shini et.al., “ Recurrent Neural Network based Text Summarization Techniques by Word Sequence Generation”,IEEE International Conference on Inventive Computation Technologies (ICICT), 2021, DOI: 10.1109/ICICT50816.2021.9358764

This page intentionally left blank



## Subject Index

16-QAM	444	backdoors	603
3D modelling	548	balanced	423
3D part calculation	73	bandwidth	368
3dB bandwidth	341	bidirectional LSTM	87
4*4 multiplier	474	big data	52, 58,179, 542
4G	517	binary to excess – 1 Converter (BEC)	558
5G	517	bit enhanced	558
absorption	300	BIV (Blockchain I-Voting)	81
accelerometer	459	black box	532
accident detection system	532	blind people navigation	316
accuracy	52	block storage	214
acupressure	145	blockchain	106, 173
adaptive beamforming	496	bone cancer	347
adaptive equalization	385	BPSK	444
adder	409	brain tumor	321, 580, 614
adenocarcinoma	129	branch line coupler	454
AES	396	broadcasting video	101
aggressiveword	194	brute force attack	241
air pollution	449	CAD design	73
alerts	199	cancer	347
allocation techniques	469	CAPTCHA codes	363
Amazon S3	542	caputo	402
anamoly detection	553	carry select adder (CSLA)	558
android	294	CBIR	52
anemia	20	CDR value	537
animation	73	central nervous system	162
anisotropic diffusion	402	cervical cancer	129
annotation architecture	101	classification	580
annotation framework design	101	cloud	246
anxiety	145	cloud computing	542
AODV	368	cloud framework	67
API calls	603	cloud server	283
Arduino	199, 209, 459	cloud sim	423
Arduino controller	283	cloud storage	434
array multipliers (AM)	380	cognitive cryptography	363
artificial intelligence	311	collaborative filtering	47
artificial neural networks (ANN)	30, 598	collision	199
assistive technology	316	combinational circuitry S-box	396
attacks	14, 608	compact	454
augmented reality	548	computer vision	331
automatic text	179	congestion	189

connected component	20	dynamic power	511
convolutional neural network (CNN)	118, 184, 234, 256, 331, 439, 553, 593, 614	eccentricity	20
cops	189	ECO-system	449
coupled quadratic congruential generator (CQCG)	396	encoding	3
COVID-19	145, 204	energy	368
cryptography	173, 396	energy efficient	423
CSF	229, 439	energy saving technology	434
CT images	73	enhanced full and half adder	474
CT imaging	347	enhancement	402
curve fitting model	35	enhancement	300
CVD	219	ensembles technique	162
cyber bullying	194	ESP8266	449
cycle of learning	229	exploratory data analysis	563
Dadda algorithm	474	extraction	155
data analysis	542	EZW	3
data anonymization	480	F1-score	9
data augmentation	234	face detection	118, 570
data center	423	face ID	256
data mining	41, 58	face mask	256
dataset preprocessing	234	face mask detection	118
datasets	542	face recognition	570
DC	511	facial expression recognition	184
DDos	608	facial recognition	354
decision making	542	fast-RNN	87
decision tree	94	fault resistance	67
deep learning	52, 118, 204, 229, 234, 256, 273, 321, 553, 598, 603, 614	FDD	444
deep learning Raspberry pi 3 processor	316	feature engineering	417
deep learning technique	168	feature extraction	580
deep neural network (DNN)	14, 35	features	224, 347
demographic data	288	FER	184
denoising	402	FFT	3
detection	224, 300	FGIS	464
diagnosis	204	file storage	214
digital marketing analysis	586	financial data	553
digital marketing strategies	586	fire sensor	278
digital voting	81	firmware	603
digitization	501	fixed infrastructure	368
distributed denial of service	241	food labelling	548
distributed ledger technologies	173	free space optical communication	341
Dos	608	FT	3
drowsiness	575	fundus image	537
dual-band band pass filter	522	fuzzy c-means	439
DWT	273	fuzzy c means clustering	294
		fuzzy clustering	268
		gateways	429
		GLCM	273, 580
		global on-chip inter connect	373
		GM	439
		Google cloud jobs	423

gray-level co-occurrence matrix (GLCM)	347	latch	511
Grunwald-Letnikov (G-L)	402	LEACH protocol	469
GSM	278	learning model	41
H7	145	LED modulation	464
hadoop	52	light emitting diode (LED)	532
health monitoring	111, 321	light-fidelity (Li-Fi)	434, 532
health tracking device	145	line profiling	111
healthcare	58, 145, 219	LMS	385
healthcare monitoring	311	loan	563
heart disease prediction	139	loan management system	106
heartrate monitor	145	log loss	9
HetNet	506	logistic regression	563
high throughput	469	LoRa	251, 429
host-based intrusion detection system (HBID)	14	LoRaWAN	429
human cancer classification	417	low power	409
human mental capability	363	low power and high-speed comparators	511
hybrid CNN-RNN	593	LSTM	139, 593
hybrid optimizations	373	lung regions	268
identity disclosure	480	lung tumor detection	268
image analysis	134	machine intelligence	417
image processing	321, 575	machine learning	14, 94, 101, 134, 194, 209, 224, 246, 261, 311, 354, 358, 553, 598
image recognition	331	magnum opus	586
improved LCMV	496	malicious URL	224
infrared thermography	111	malversation	189
instinctive methodology	229	malware	603
insurance	501	manhole cover	429
intelligent data algorithms	123	measurement	341, 496
intelligent healthcare	321	medical devices	311
intensity modulation direct detection	517	medical image	402
inter symbol interference	385	MEMS sensor	278
interaction data	47	microarray gene dataset	417
internet of things (IoT)	189, 209, 283, 311, 354, 358, 373, 434, 449, 570, 603	microcontroller	527
interpersonal dependency	25	microstrip	522
intrusion detection system (IDS)	14	military personnel	251
ISI	444	MIMO-OFDM	464
Jaccard index	9	minimal delay	558
k-anonymity	480	mobile adhoc networks	368
k-means clustering	294	mobile face net algorithm	570
k-nearest neighbor	246, 347	modulation	517
k-nearest neighbor algorithm	9	mondrian	480
KDO	41	monitoring	199
ketocheck	294	morphological image processing	111
lane detection	35	MRDTL	41
lane tracking	35	MRI	347
		MSE	444
		multi grade	321

multi-core	423	PPM	341
multi-dimensional	423	pre-processing	155
multi-level authentication	363	preamplifier	511
multi-threshold complementary metal oxide semiconductor (MTCMOS)	409	prediction	563
multimedia system-on-chip (MSoC)	373	privacy	173
multiple semantic spider hunting	390	privacy preserving data publishing	480
multiple spider model	390	pro semantic ranker	491
multiplier	409	pseudonymous data	480
mutual induction	527	pulse rate sensor	459
MUX logic	474	pulse-sensor	527
naïve Bayes	94, 246	QoS	506
native app development	570	QPSK	444
natural language processing (NLP)	87, 491	question generation	491
navigation	326	random bit sequence	396
negative password generation	241	random forest	224, 603
negative traits	25	ranking	491
network lifetime	368	reading assistant	316
neural network	101, 139, 268, 575	recognition	155, 256
neural network model	553	regional cinema	586
neuro degenerative disease	162	regression	288
no parking area	189	relational attribute	41
object storage	214	relational table	41
OFDM	444, 517	reliable	67
offset voltage	511	restoration	300
opinion mining	261	RF communication	251
optical character recognition	501	Riemann-Liouville (R-L)	402
OSN	47	risk factors	129, 168, 219
osteopenia	58	RNN	593
osteoporosis	58	ROI	439
OWC	464	RT-PCR	204
PAM	341	scalability	173
pancreatic cancer	273	scattering	300
Parkinson's disease	162	secure data protection	305
PC	229	security	173, 246
PDM	341	security system	354
performance	341, 496	segmentation	155, 580
personality traits	25	segmentation accuracy	87
phase jitter	341	self-attention	331
PNN	273	self-esteem	25
point-to-point-based interconnection (PTP-BI)	373	self-reliance	326
police	189	sensitive data exposure	305
postpartum haemorrhage	168	sensor	283
power consumption	409	sensors	123, 283, 326, 434
power spectral density	444	sentimental analysis	261
		sentimental classification	261
		sickle	20
		SINR	506
		size reduction	454
		skin disease	234

skull stripping	439	toxic gases	449
sliding window	35	trackback	608
smart car	199	tracking	251
smart city	429	transaction data	288
smart contracts	106	transmission lines	454
smart energy meter system	358	trust	47
smart security system	570	UFMC	385, 517
SNR	444	ultrasound image	273
sobel filter	35	unsupervised machine learning (UML)	41, 294
social media	194, 542	urban sensing	67
space partition model	423	user privacy	106
SPIHT	3	user recommendation	47
sports	123	vedic multiplier (VM)	380
sports video annotation	101	vibration sensor	278
SQL injection	241	virtual machine placement	423
squamous cell carcinoma	129	visible light communication (VLC)	464, 532
SSD algorithm	570	vision transformers	331
stepped-impedance resonator	522	visualization	501
storage optimization	214	visually impaired	316
stored data	532	VLPD	155
stress	145	VLSI technology	409
STW	3	voting	81
sub topic detection	390	wallace tree multiplier (WTM)	380
suffocation	199	wavelet	3
SVM	58, 134, 246	wearable devices	123
T-shaped structure	454	weather	209
technical training	123	weather monitoring	434
Telugu cinema	586	web application security	305
temperature sensor	459	web services	214
tensor flow	614	wireless charging	527
tensor flow technique	30	wireless communication	326
text segmentation	87	wireless network	469
text summary	179	wireless-fidelity (Wi-Fi)	434, 532
The Things Network	429	WM	439
thingspeak	358	women	129, 168
threat detection	326	wrist band	145
three stage course	229	X-mondrian	480
thresholding	73, 111	X-ray	347
tiny AES Substitution byte and its inverse	396	XML external entity	305
tomato disease classification	593	ZigBee	459
topic detection	390		

This page intentionally left blank

## Author Index

Aashika V	570	Chiranthan YC	134
Abinaya.B	527	ChristiyanaArulselvi A	47
Abirami.A.P	527	Dafni Rose, J	491
Aditya Gowrish, M.	331	David, H.E.	593
AdlinLayola J.A	234	Deepa B	537
Aishwarya I	532	Deepa S	496
Ajithkumar, S S	491	Deepak Kumar A	106
AkashS	162	Deepika R	268, 273
AkilandeswariD	162	Deepika T	614
AmalaRani, V.	3	Deepika. R	548
Amaysingh	14	Deepika.R	278
Ambeth Kumar, V.D. v, 168, 179, 219		Deshmukh, R.	429
Ameelia Roseline A	506	Dhanalakshmi R	417
Anand, M.	511	Dhananja	134
Anciline V	522	dharshini, P.	145
Annadurai, C.	300, 354	Dhivya S	570
Annadurai. C	358	Divya.J	527
Anuratha, K.	553	DivyaS	278
Anusha K	570	Doreen Hephzibah Miriam D	155
Aravind Prakash M	14	Elakiya, E.	390
Aravind, J.M.	341	Elangovan G	311
Arikumar K S	106	Elangovan, D.	261
Arul Teen, Y.P.	341	Elangovan.D	194, 326
Arul, E.	603	Elavel Visuvanathan. G	385
Ashok Kumar, V.	603	Elumalai. G	449
AshokkumarS	184	Emalda Roslin, S.	111
Balaji, S	214	Ezhilarasi P	145
BalajiS	184	Fah Tee, K.	409
Balamurugan, K.	396	Favorskaya, M.	v
Balas, V.E.	v	GaneshGaurav, D.	134
Balasundaram A	214	Ganga A	268, 288
BalasundaramA	184	Ganga, M.	402
Baskar M	537	George, P.M.	9
Belshia Jebamalar G	241	Gnanasekaran T	598
Beulah, A.	20	Gopinath, M.	563
Bharathi, S.L.	380	GowthamC	106
Bharkavi A G	251	Gunasekaran, K.	603
Bhuvaneswari B	444	Hajara FathimaS	139
Carolyn B	532	Hari Priya K	256
Chakravarthi, R.	111	Haritha, P.	229
ChalceEbenS	532	Haritha.V	209
Chaudhari, P.	429	Harshitha S V	316
Chidambaram, N.	101	Hemachandran K	9

Hemalatha, G.	593	Kumar Tiwari, A.	429
Indhuja G	570	Kumar, A.	586, 586
Indhumathi.M	219	LakshmanaPandian.S	87
IndiraniG	139	Lakshmi, S.	162
Indra Gandhi K	14	Lalitha, V.	199
Indumathi.P	368	LalithaKumari, S	3
Jagadeeshwaran P	162	Leones Sherwin VimalrajS	464
Jainab Zareena, S.	25	Lingamuthu K	537
Janaki Rani, M.	511	Logashanmugam.E	52
Janakiraman, N.	396, 402	Lydia J	464
JananiK	162	Lydia Sharon Rose G	506
Jansi, K.R.	67	Madhubala.D	194
Jaswanthi R	316	Magesh Kumar S	214
Jaya. T	385	Mahalakshmi G S	47
Jayanthi S	139	Maheswari S	251, 454, 522
Jayanthi, S.	417	Malathi S	256, 321
Jayashree S	316	Malathi, S.	v, 229
Jayashree T R	434	Manasvini, S.R.	209
Jayashree, D.	81	Manoj Kumar B	273
Jayshree	373	Manonmani.A	162
Jeevitha R	439	Mathusathana. V	358
Jesgna, A.	251	Meera.S	209, 278
Jeshoorin G	501	Meha Soman S	570
Jessica Pauline, S	251	Merlin G	537
Jothika. D. E	575	Michael, T.	41
Jutru, V.	454	MudassarAli, A.	214
Juvvigunta, J.	586	MuraliBhaskharan, V.	234
Kalaiyarasi, D	459	Muralidhar, A.	396, 402, 409, 417
Kalaiyarasi, D.	380	Muthiah.M.A	52
Kalaiyarasi.D	474	Muthulakshmi, K.	246
Kalpana R A	288	Nagadevi	423
Kalpana R. A	268	Nallavan, G.	101, 123
Kalpana.R.A	209	Nallavan. G	449
Kalpana.K	409	Nandhini Devi R	464
Kanagaraj, R.	390	Nandhini J.M	598
Kanchana Devi A	444	Nandhitha, N.M.	111
Kannan, P.	532	Nandhitha.N.M	52
Karthika. S	548	Narendhiran.S	326
KasmirRaja, S.V.	67	Nelson, I.	300, 354, 358
Kaviya K R	496	NimmyLazer	341
Keerthivasan K	517	Nirmala Devi, S.	294
Kiruthiga Devi M	268, 273, 537	NirmalaDevi, S.	73
KomalBharti	134	Nisha.Y	283
Krithika, M.	25	Nithya, M.	199
Kulkarni, R.M.	9	Nithya, N.	123
Kumar Dahlan, M.	331	Padmaja, R.	480
Kumar Padhy, M.	586	Padmapriya.D	474
Kumar Sivaraman, A.	396, 402, 409, 417	Pandian, R.	3
		Pandian.R	30, 35



PandianR	368	Ramya, S.	580
Pandithurai, O.	81	Ramya. E	358
Parthasarathy G	118, 134, 173	Ranald Nivethan, X.N.	354
Pati, D.	373	Ranjith Raj B	145
Pattewar, S.	429	RashmiS	118
Paulchamy. B	409	Ravindran, P.	402, 417
Perumal, T.	v	Rene Robin C R	155
Prabhakar.M	305	ReneRobin, C.R.	139
PrabhuDassBatvari, B.	3	Revathy P	241
Prakash, M.	94	Rodriguez, R.V.	9
Pravin.A	368	Roy, S.	9
PremJacob.T	30, 35, 368	Ruphitha, S.V.	168
Prema, R.	580	SahayaBeniPrathiba	106
Premi.A	469	Sai Sumitra, J.C.E	199
Pritha, N.	380	SaiSupriya N	118
Pritha.N	474	Sakthi, U	491
Priya B	598	Samundeswari S	501
Priya V	608	Sandhia, G.K.	67
Priya.R	194	Sangeetha, M.S.	111
Priyadarshini K	434	SankarGanesh, N	155
Priyadarshini V S	278	Santhi, V.	480
Priyadarshini, R.	553	Santhi.V	58
Priyadharsini, R.	20	Saravanan A	184
Priyadharsini. R	409	Saravanan.M.S	129
Priyanka	118	Sarojini, V.L.S.S.	145
Priyanka, K.	179	Satheesh Kumar, B	347
Puneeth R P	173	Sathish Kumar P J	184
Punidha, A.	603	Sathish N	311
Pushkala V	294	SathishKumar, P J	214
Radhakrishnan, P	603	Sathiyaprasad. B	347
Radhakrishnan.P	326	Seetharaman, G.	373
Radhika	363	Selvaraj D	439
Raja, K.	423	Sendhilkumar S	47
RajaKumar, R.	3	Senthil Kumar, M.	354
RajaKumar.R	30	Sethuraman, R.	563
Rajakumar.R	35, 368	Shalini, A.	81
Rajakumar.S	469	Sharmikha Sree.R	209
Rajalakshmi, R.	511	SharmikhaSree.R	278
Rajalakshmi.R	527	Sheela. S	575
Rajendiran. M	194, 204	SheelaS	580
Rajendran, N.	553	Shibu S	517
Rajesh K. B.	341	Shivani. R	358
Rajesh Kannan S	145	Shrinivas Badri.S	300
Rajesh, A.	129	Shruthi S	145, 614
Rajkumar, N.	390	Shruthi. V	459
Ramakrishnan. R	449	Sindhu, V.	94
Ramalakshmi, K.	593	Singh, P.	586
Ramesh.T	58	Sivagurunathan M	224
Ramya N	268, 273	Sivakumar.P	363

SivakumarP	224	Swetha, K B	81
Sivaranjani P	608	Swetha, R.	73
Sivasakthi, T.	558	Syed, A.R.	305
SmithiRam	614	Thirumahal, B.	580
Somasundaram. S K	224	Valarmathi K	189, 311
Somasundaram.S K	363	Valarmathi, K.	209, 246, 283
Sornalatha, R.	396	Vanaja.S	459
SoundaryaLahari, M.V.S.	199	Vanitha N	155
Sowmiya K	542	Varsha.G	548
Sravya V J	321	Varshaa, P.	558
Sri Harini, K.	434	Vasanth M	501
Srinivas Shankar Maheep, K.	563	Venkatasubramani, S.	300
Sriram R	14	Venkatesan, R.	593
Srivarshini, R.	558	Vijay Balaji B	273
Srividhya, G.	380, 558	Vijay K	608
Srividhya.G	474	Vijayakumar R	608
Subedha, V.	261	Vijayalakshmi S	288
SubhaShini, R.	179	Vijayalakshmi, S.	558
Subhashini, R.	331, 542	Vimala, S.	229
Sujeetha, S.	553	Vincent, R.	396, 402, 409, 417
Sumithra M	614	Vinod, S.	354
Supriya S	542	Vinotheni.C	87
Surender Dhanunjay, G.	586	Vishali. B. R	575
Suthanthara Raja PushpaJ	189	VishnuPraba.A	459
Swarnapriya. N	575	Yamini, L.	20
Swathi S	614	Yogesh.I	300
Swetha.M	204	Yogeswari, S	81